

**TECHNICAL MANUAL  
UNIT, DIRECT SUPPORT AND  
GENERAL SUPPORT MAINTENANCE  
REPAIR PARTS AND SPECIAL TOOLS LIST  
FOR**

TRUCK, UTILITY: CARGO/TROOP CARRIER, 1-1/4 TON, 4X4, M998 (2320-01-107-7155) (EIC: BBD);  
M998A1 (2320-01-371-9577) (EIC: BBN);

TRUCK, UTILITY: CARGO/TROOP CARRIER, 1-1/4 TON, 4X4, W/WINCH, M1038 (2320-01-107-7156) (EIC: BBE);  
M1038A1 (2320-01-371-9578) (EIC: BBP);

TRUCK, UTILITY: HEAVY VARIANT, 4X4, M1097 (2320-01-346-9317) (EIC: BBM);  
M1097A1 (2320-01-371-9583) (EIC: BBU); M1097A2 (2320-01-380-8604) (EIC: BB6);  
M1123 (2320-01-455-9593) (EIC: B6G);

TRUCK, UTILITY: TOW CARRIER, ARMORED, 1-1/4 TON, 4X4, M966 (2320-01-107-7153) (EIC: BBC);  
M966A1 (2320-01-372-3932) (EIC: BBX); M1121 (2320-01-456-1282) (EIC: B6H);

TRUCK, UTILITY: TOW CARRIER, W/SUPPLEMENTAL ARMOR, 1-1/4 TON, 4X4, M1045 (2320-01-146-7191);  
M1045A1 (2320-01-371-9580) (EIC: BBR); M1045A2 (2320-01-380-8229) (EIC: BB5);

TRUCK, UTILITY: TOW CARRIER, W/SUPPLEMENTAL ARMOR, 1-1/4 TON, 4X4, W/WINCH, M1046 (2320-01-146-7188);  
M1046A1 (2320-01-371-9582) (EIC: BBT);

TRUCK, UTILITY: ARMAMENT CARRIER, ARMORED, 1-1/4 TON, 4X4, M1025  
(2320-01-128-9551) (EIC: BBF); M1025A1 (2320-01-371-9584) (EIC: BBV); M1025A2 (2320-01-380-8233) (EIC: BB3);

TRUCK, UTILITY: ARMAMENT CARRIER, ARMORED, 1-1/4 TON, 4X4, W/WINCH, M1026 (2320-01-128-9552) (EIC: BBG);  
M1026A1 (2320-01-371-9579) (EIC: BBQ);

TRUCK, UTILITY: ARMAMENT CARRIER, W/SUPPLEMENTAL ARMOR, 1-1/4 TON, 4X4, M1043 (2320-01-146-7190);  
M1043A1 (2320-01-372-3933) (EIC: BBY); M1043A2 (2320-01-380-8213) (EIC: BB4);

TRUCK, UTILITY: ARMAMENT CARRIER, W/SUPPLEMENTAL ARMOR, 1-1/4 TON, 4X4, W/WINCH, M1044 (2320-01-146-7189);  
M1044A1 (2320-01-371-9581) (EIC: BBS);

TRUCK, UTILITY: S250 SHELTER CARRIER, 4X4, M1037 (2320-01-146-7193) (EIC: BBK);

TRUCK, UTILITY: S250 SHELTER CARRIER, 4X4, W/WINCH, M1042 (2320-01-146-7187);

TRUCK, AMBULANCE, 2-LITTER, ARMORED, 4X4, M996 (2310-01-111-2275) (EIC: BBB);  
M996A1 (2310-01-372-3935) (EIC: BB2);

TRUCK, AMBULANCE, 4-LITTER, ARMORED, 4X4, M997 (2310-01-111-2274) (EIC: BBA); M997A1  
(2310-01-372-3934) (EIC: BBZ); M997A2 (2310-01-380-8225) (EIC: BB8);

TRUCK, AMBULANCE, 2-LITTER, SOFT TOP, 4X4, M1035 (2310-01-146-7194); M1035A1 (2310-01-371-9585) (EIC: BBW);  
M1035A2 (2310-01-380-8290) (EIC: BB9).

**Approved for public release; distribution is unlimited.**

---

**HEADQUARTERS, DEPARTMENTS OF THE ARMY,  
THE AIR FORCE, AND MARINE CORPS**

**MARCH 2001**

**LIST OF EFFECTIVE PAGES**

Date of issue of volume 1 is: 30 March 2001

Date of issue of volume 2 is: 30 March 2001

Revision ..... 0 .....30 March 2001

Revision ..... 0 ..... March 2001

Volume 1 contains 956 pages

Volume 2 contains 875 pages

TOTAL NUMBER OF PAGES IN THIS PUBLICATION IS 956. CONSISTING OF THE FOLLOWING:

Page No. ....*Change No.	Page No. ....*Change No.
<b>VOLUME 1</b>	
A .....0	A .....0
B Blank .....0	B Blank .....0
i - xv .....0	i - vi .....0
xvi blank .....0	vii blank .....0
1 - 12 .....0	Figure 329 - Page 498-1 .....0
Figure 1 - Page 328-1 .....0	Kits-1 - Kits - 20 .....0
	Bulk-1 - Bulk- 3 .....0
	Figure 499-1 - Page 512-1 .....0
	Index 1 - Index 314 .....0

\*Zero in this column indicates original page.

A/(B Blank)

**TECHNICAL MANUAL  
NO. 9-2320-280-24P-1  
NO. 2320-24P/8B**

**HEADQUARTERS, DEPARTMENTS  
OF THE ARMY, THE  
AIR FORCE, AND MARINE CORPS**

**TECHNICAL ORDER  
NO. 36A12-1A-3044-1**

**WASHINGTON, D.C. 30 March 2001**

**TECHNICAL MANUAL  
VOLUME 1 OF 2  
UNIT, DIRECT SUPPORT AND GENERAL SUPPORT MAINTENANCE  
REPAIR PARTS AND SPECIAL TOOLS LIST  
FOR**

TRUCK, UTILITY: CARGO/TROOP CARRIER, 1-1/4 TON, 4X4, M998 (2320-01-107-7155) (EIC: BBD);  
M998A1 (2320-01-371-9577) (EIC: BBN);

TRUCK, UTILITY: CARGO/TROOP CARRIER, 1-1/4 TON, 4X4, W/WINCH, M1038 (2320-01-107-7156) (EIC: BBE);  
M1038A1 (2320-01-371-9578) (EIC: BBP);

TRUCK, UTILITY: HEAVY VARIANT, 4X4, M1097 (2320-01-346-9317) (EIC: BBM);  
M1097A1 (2320-01-371-9583) (EIC: BBU); M1097A2 (2320-01-380-8604) (EIC: BB6);  
M1123 (2320-01-455-9593) (EIC: B6G);

TRUCK, UTILITY: TOW CARRIER, ARMORED, 1-1/4 TON, 4X4, M966 (2320-01-107-7153) (EIC: BBC);  
M966A1 (2320-01-372-3932) (EIC: BBX); M1121 (2320-01-456-1282) (EIC: B6H);

TRUCK, UTILITY: TOW CARRIER, W/SUPPLEMENTAL ARMOR, 1-1/4 TON, 4X4, M1045 (2320-01-146-7191);  
M1045A1 (2320-01-371-9580) (EIC: BBR); M1045A2 (2320-01-380-8229) (EIC: BB5);

TRUCK, UTILITY: TOW CARRIER, W/SUPPLEMENTAL ARMOR, 1-1/4 TON, 4X4, W/WINCH, M1046 (2320-01-146-7188);  
M1046A1 (2320-01-371-9582) (EIC: BBT);

TRUCK, UTILITY: ARMAMENT CARRIER, ARMORED, 1-1/4 TON, 4X4, M1025  
(2320-01-128-9551) (EIC: BBF); M1025A1 (2320-01-371-9584) (EIC: BBV); M1025A2 (2320-01-380-8233) (EIC: BB3);

TRUCK, UTILITY: ARMAMENT CARRIER, ARMORED, 1-1/4 TON, 4X4, W/WINCH, M1026 (2320-01-128-9552) (EIC: BBG);  
M1026A1 (2320-01-371-9579) (EIC: BBQ);

TRUCK, UTILITY: ARMAMENT CARRIER, W/SUPPLEMENTAL ARMOR, 1-1/4 TON, 4X4, M1043 (2320-01-146-7190);  
M1043A1 (2320-01-372-3933) (EIC: BBY); M1043A2 (2320-01-380-8213) (EIC: BB4);

TRUCK, UTILITY: ARMAMENT CARRIER, W/SUPPLEMENTAL ARMOR, 1-1/4 TON, 4X4, W/WINCH, M1044 (2320-01-146-7189);  
M1044A1 (2320-01-371-9581) (EIC: BBS);

TRUCK, UTILITY: S250 SHELTER CARRIER, 4X4, M1037 (2320-01-146-7193) (EIC: BBK);

TRUCK, UTILITY: S250 SHELTER CARRIER, 4X4, W/WINCH, M1042 (2320-01-146-7187);

TRUCK, AMBULANCE, 2-LITTER, ARMORED, 4X4, M996 (2310-01-111-2275) (EIC: BBB);  
M996A1 (2310-01-372-3935) (EIC: BB2);

TRUCK, AMBULANCE, 4-LITTER, ARMORED, 4X4, M997 (2310-01-111-2274) (EIC: BBA); M997A1  
(2310-01-372-3934) (EIC: BBZ); M997A2 (2310-01-380-8225) (EIC: BB8);

TRUCK, AMBULANCE, 2-LITTER, SOFT TOP, 4X4, M1035 (2310-01-146-7194); M1035A1 (2310-01-371-9585) (EIC: BBW);  
M1035A2 (2310-01-380-8290) (EIC: BB9).

Current as of 1 January 2001

**REPORTING ERRORS AND RECOMMENDING IMPROVEMENTS**

You can help improve this publication. If you find any mistakes or if you know of a way to improve the procedures, please let us know. Submit your DA Form 2028 (Recommended Changes to Equipment Technical Publications), through the Internet, on the Army Electronic Product Support (AEPS) website. The Internet address is <http://aeprs.ria.army.mil>. If you need a password, scroll down and click on "ACCESS REQUEST FORM". The DA Form 2028 is located in the ONLINE FORMS PROCESSING section of the AEPS. Fill out the form and click on SUBMIT. Using this form on the AEPS will enable us to respond quicker to your comments and better manage the DA Form 2028 program. You may also mail, fax or E-mail your letter or DA Form 2028 direct to: AMSTA-LC-CI/TECH PUBS, TACOM-RI, 1 Rock Island Arsenal, Rock Island, IL 61299-7630. The email address is TACOM-TECH-PUBS@ria.army.mil. The fax number is DSN 793-0726 or Commercial (309) 782-0726.

Approved for public release; distribution is unlimited.

\* This manual supersedes TM 9-2320-280-24P-1, dated 31 January 1996.

**TABLE OF CONTENTS**  
**VOLUME 1 OF 2**

		Page	Illus Figure
Section I	INTRODUCTION . . . . .	1	
Section II	REPAIR PARTS LIST . . . . .	1-1	
Group 01	Engine . . . . .	1-1	1
	0100 Engine and container assembly . . . . .	1-1	1
	0100 Engine mounting brackets . . . . .	2-1	2
	0106 Engine oil dipstick and tube assembly . . . . .	3-1	3
	0106 Engine oil pan, pump, and filler tube . . . . .	4-1	4
	0106 Engine and transmission oil cooler and engine oil cooler lines . . . . .	5-1	5
	0106 Oil filter, adapter, and oil line fittings. . . . .	6-1	6
	0106 Crankcase depression regulator valve and mounting hardware . . . . .	7-1	7
	0108 Air intake and exhaust manifolds. . . . .	8-1	8
Group 03	Fuel system . . . . .	9-1	9
	0302 Fuel pump and mounting hardware . . . . .	9-1	9
	0302 Fuel injection pump and fuel filter lines . . . . .	10-1	10
	0302 Fuel injection supply and return lines. . . . .	11-1	11
	0304 Air cleaner, air horn, and related parts. . . . .	12-1	12
	0306 Fuel tank supply and return lines, (Early models) . . . . .	13-1	13
	0306 Fuel tank supply and return lines, (Current models) . . . . .	14-1	14
	0306 Fuel tank assembly and mounting straps . . . . .	15-1	15
	0306 Fuel tank assembly and mounting straps . . . . .	16-1	16
	0306 Fuel filler pipe assembly and vent lines . . . . .	17-1	17
	0306 Fuel tank vent line, filter, and mounting hardware . . . . .	18-1	18
	0309 Fuel filter assembly/water separator and mounting hardware . . . . .	19-1	19
	0311 Glow plug . . . . .	20-1	20
	0312 Accelerator controls and hand throttle . . . . .	21-1	21
	0312 Accelerator cable bracket and idle spring . . . . .	22-1	22
Group 04	Exhaust system . . . . .	23-1	23
	0401 Muffler, exhaust pipes, and related parts . . . . .	23-1	23
	0401 Muffler, exhaust pipes, and related parts . . . . .	24-1	24
	0401 Exhaust manifold heat shield. . . . .	25-1	25
Group 05	Cooling system . . . . .	26-1	26
	0501 Radiator and mounting hardware. . . . .	26-1	26
	0501 Surge tank and related parts . . . . .	27-1	27
	0502 Radiator shroud and related parts . . . . .	28-1	28
	0503 Radiator hoses and related parts . . . . .	29-1	29
	0503 Thermostat, water crossover, and attaching hardware . . . . .	30-1	30
	0504 Water pump and attaching hardware . . . . .	31-1	31
	0505 Fan assemblies and belts . . . . .	32-1	32
	0505 Tensioner, idler pulley, and mounting hardware . . . . .	33-1	33
	0505 Fan drive and pulley . . . . .	34-1	34
Group 06	Electrical system . . . . .	35-1	35
	0601 Generator, 60 AMP, 100 AMP, belts, pulley, and mounting hardware . . . . .	35-1	35
	0601 100 AMP alternator (NIEHOFF) and mounting hardware . . . . .	36-1	36
	0601 200 AMP alternator assembly, belts, pulley, guard, and mounting hardware, M996, M996A1, M997, M997A1, M1097, and M1097A1 . . . . .	37-1	37
	0601 200 AMP alternator (NIEHOFF) mounting hardware . . . . .	38-1	38
	0601 200 AMP alternator, M996, M996A1, M997, M997A1, M1097, and M1097A1 (PRESTOLITE) . . . . .	39-1	39



## TABLE OF CONTENTS (Cont'd)

	Page	Illus Figure
0601 200 AMP alternator, M996, M996A1, M997, M997A1, M997A2, M1097, M1097A1, M1097A2, and M1123 (NIEHOFF) . . . . .	40-1	40
0601 A2 alternator wiring harness . . . . .	41-1	41
0601 Kit, 60, 100, and 200 AMP alternator mounting hardware . . . .	42-1	42
0601 Generator assembly (60 AMP) . . . . .	43-1	43
0603 Starter motor, cable assemblies, and mounting hardware. . . .	44-1	44
0603 Starter motor assembly . . . . .	45-1	45
0607 Instrument panel assembly and mounting hardware . . . . .	46-1	46
0607 Instrument cluster assembly . . . . .	47-1	47
0607 Circuit breakers . . . . .	48-1	48
0608 Directional control unit, protective control box, and directional flasher . . . . .	49-1	49
0608 Transmission control module, circuit breaker, and relay . . . .	50-1	50
0608 Stoplight switch, time delay module, and high beam selector switch. . . . .	51-1	51
0608 Control box assembly, M996, M996A1, M997, M997A1, and M997A2 ambulance. . . . .	52-1	52
0608 Control box assembly, M996, M996A1, M997, M997A1, and M997A2 ambulance . . . . .	53-1	53
0608 Air conditioner and heater control box, M997, M997A1, and M997A2 ambulance. . . . .	54-1	54
0608 Personnel heater/vent and A/C control panel, M997, M997A1, and M997A2 ambulance. . . . .	55-1	55
0608 Personnel heater/vent A/C control panel, M996 and M996A1 ambulance . . . . .	56-1	56
0608 24V DC outlet, rear, M996, M996A1, M997, M997A1, and M997A2 ambulance. . . . .	57-1	57
0608 Front and rear blackout switches, M996, M996A1, M997, M997A1, and M997A2 ambulance. . . . .	58-1	58
0608 NBC control panel, M996, M996A1, M997, M997A1, and M997A2 ambulance. . . . .	59-1	59
0609 Front composite light and mounting hardware . . . . .	60-1	60
0609 Rear composite light and mounting hardware . . . . .	61-1	61
0609 Blackout lamp and headlight assembly. . . . .	62-1	62
0609 Clearance marker light assembly. . . . .	63-1	63
0609 Backup light assembly and mounting hardware. . . . .	64-1	64
0609 Blackout, dome, and spotlight, M996, M996A1, M997, M997A1, and M997A2 ambulance. . . . .	65-1	65
0610 Sending units . . . . .	66-1	66
0610 Fuel pressure transducer, fuel level transmitter, parking brake, backup light switches, and transfer indicator switch. . . . .	67-1	67
0611 Horn and horn button assembly. . . . .	68-1	68
0612 Batteries, cables, and related parts. . . . .	69-1	69
0612 Buss bar and related parts . . . . .	70-1	70
0612 Battery mounting components and related parts . . . . .	71-1	71
0612 Slave receptacle and cable assemblies. . . . .	72-1	72
0612 Slave receptacle and cable assemblies. . . . .	73-1	73
0612 200 AMP umbilical power cable . . . . .	74-1	74
0613 Engine wiring harness . . . . .	75-1	75
0613 A2 engine wiring harness. . . . .	76-1	76
0613 A2 engine wiring harness installation. . . . .	77-1	77
0613 A2 transmission wiring harness . . . . .	78-1	78
0613 STE/ICE wiring harness . . . . .	79-1	79

TABLE OF CONTENTS (Cont'd)

	Page	Illus Figure
0613 Hood wiring harness . . . . .	80-1	80
0613 Body wiring harness and fuel tank jumper assembly . . . . .	81-1	81
0613 Body wiring harness, ambulance . . . . .	82-1	82
0613 Body wiring harness – partial view. . . . .	83-1	83
0613 Body wiring harness – partial view. . . . .	84-1	84
0613 Body wiring harness – partial view. . . . .	85-1	85
0613 A2 body wiring harness . . . . .	86-1	86
0613 Ambulance body wiring harness, M997A2 and M1035A2 . . . . .	87-1	87
0613 A2 body wiring harness installation . . . . .	88-1	88
0613 Air-conditioner jumper cable, M997, M997A1, and M997A2 ambulance . . . . .	89-1	89
0613 Wiring harness, blackout jumper switch, M996, M996A1, M997, M997A1, and M997A2 ambulance. . . . .	90-1	90
0613 Main power cable assembly, M996, M996A1, M997, M997A1, and M997A2 ambulance . . . . .	91-1	91
0613 Interior lighting harness assembly, M996, M996A1, M997, M997A1, and M997A2 ambulance. . . . .	92-1	92
0613 Heating/vent harness assembly, M996 and M996A1 ambulance	93-1	93
0613 Aspirator/resuscitator cable assembly, M996, M996A1, M997, M997A1, and M997A2 ambulance. . . . .	94-1	94
0613 NBC wiring harness, M997, M997A1, and M997A2 ambulance.	95-1	95
0613 NBC wiring harness, M996 and M996A1 ambulance . . . . .	96-1	96
Group 07 Transmission . . . . .	97-1	97
0705 Transmission and transfer control assembly and shift rod . . . . .	97-1	97
0705 Transmission shift control and neutral start switch. . . . .	98-1	98
0705 Transmission shift control and neutral start switch. . . . .	99-1	99
0705 Transmission shift controls and modulator . . . . .	100-1	100
0705 Transmission shift lever, shift bracket, and rod. . . . .	101-1	101
0708 Torque converter . . . . .	102-1	102
0710 Transmission mounting hardware, fluid dipstick, and tube assembly. . . . .	103-1	103
0710 Transmission assembly . . . . .	104-1	104
0710 Transmission assembly . . . . .	105-1	105
0710 Planetary gear carrier . . . . .	106-1	106
0710 Planetary gear carrier . . . . .	107-1	107
0710 Parking lock system . . . . .	108-1	108
0713 Direct clutch assembly. . . . .	109-1	109
0713 Direct clutch assembly. . . . .	110-1	110
0713 Forward clutch . . . . .	111-1	111
0713 Forward clutch . . . . .	112-1	112
0713 Intermediate clutch and center support assembly . . . . .	113-1	113
0713 Intermediate clutch and center support assembly . . . . .	114-1	114
0713 Overrun, overdrive, and fourth clutch assembly. . . . .	115-1	115
0714 Front servo, rear servo, and governor assembly. . . . .	116-1	116
0714 Front servo, rear servo, and governor assembly. . . . .	117-1	117
0714 Control valve and related parts . . . . .	118-1	118
0714 Control valve and related parts . . . . .	119-1	119
0714 Control valve, accumulator, and related parts . . . . .	120-1	120
0721 Transmission oil pump. . . . .	121-1	121
0721 Transmission oil pump. . . . .	122-1	122
0721 Transmission vent lines and attaching hardware. . . . .	123-1	123
0721 Transmission/transfer cooling lines. . . . .	124-1	124
0721 Transmission/transfer cooling lines. . . . .	125-1	125

## TABLE OF CONTENTS (Cont'd)

		Page	Illus Figure
Group 08	Transfer assembly. . . . .	126-1	126
	0801 Transfer case, w/container . . . . .	126-1	126
	0801 Transfer assembly. . . . .	127-1	127
	0801 Transfer case assembly, P/N 12340073-1. . . . .	128-1	128
	0801 Transfer case assembly, P/N 5937387, 12342643-1, 12447125 (front half) . . . . .	129-1	129
	0801 Transfer case assembly, P/N 5937387, 12342643-1, 12447125 (rear half) . . . . .	130-1	130
	0801 Transfer oil cooler assembly. . . . .	131-1	131
	0801 Transfer shift mechanisms. . . . .	132-1	132
	0803 Transfer shift controls . . . . .	133-1	133
	0803 Transfer shift controls . . . . .	134-1	134
	0804 Transfer case vent lines and related parts. . . . .	135-1	135
Group 09	Propeller shafts . . . . .	136-1	136
	0900 Front propeller shaft assemblies . . . . .	136-1	136
	0900 Rear propeller shaft assemblies . . . . .	137-1	137
Group 10	Front axle . . . . .	138-1	138
	1000 Front halfshaft assembly, left and right side . . . . .	138-1	138
	1000 Front halfshaft assembly, left and right side . . . . .	139-1	139
	1002 Front axle differential, mounting bracket, and hardware . . . . .	140-1	140
	1002 Front axle differential and geared hub vent lines . . . . .	141-1	141
	1004 Front knuckle and geared hub assembly. . . . .	142-1	142
	1004 Front knuckle and geared hub assembly. . . . .	143-1	143
	1004 Front control arms, ball joints, and mounting hardware . . . . .	144-1	144
Group 11	Rear axle . . . . .	145-1	145
	1100 Rear halfshaft assembly, left and right side . . . . .	145-1	145
	1100 Rear halfshaft assembly, left and right side . . . . .	146-1	146
	1102 Rear axle differential, mounting brackets, and hardware . . . . .	147-1	147
	1102 Axle differential . . . . .	148-1	148
	1102 Rear axle differential and geared hub vent lines . . . . .	149-1	149
	1104 Rear knuckle and geared hub assembly . . . . .	150-1	150
	1104 Rear knuckle and geared hub assembly . . . . .	151-1	151
	1104 Rear control arms, ball joints, and mounting hardware . . . . .	152-1	152
Group 12	Brakes . . . . .	153-1	153
	1201 Parking brake hand lever and cable . . . . .	153-1	153
	1201 Parking brake rod and related parts. . . . .	154-1	154
	1201 Parking brake cables and mounting hardware. . . . .	155-1	155
	1201 Parking brake caliper, rotor, and mounting hardware . . . . .	156-1	156
	1201 Rear parking brake and caliper assembly . . . . .	157-1	157
	1202 Service brake caliper assembly and rotor . . . . .	158-1	158
	1204 Front service brake lines and proportioning valve . . . . .	159-1	159
	1204 Front service brake lines and proportioning valve . . . . .	160-1	160
	1204 Rear brake lines and fittings . . . . .	161-1	161
	1204 Rear brake lines and fittings . . . . .	162-1	162
	1204 Master cylinder assembly. . . . .	163-1	163
	1205 Hydro booster . . . . .	164-1	164
	1206 Service brake pedal assembly. . . . .	165-1	165
	1206 Service brake pedal assembly. . . . .	166-1	166
Group 13	Wheels. . . . .	167-1	167
	1311 Wheel and runflat assembly. . . . .	167-1	167
	1313 Tires. . . . .	168-1	168

TABLE OF CONTENTS (Cont'd)

		Page	Illus Figure
Group 14	Steering . . . . .	169-1	169
	1401 Steering column, wheel, and intermediate shaft . . . . .	169-1	169
	1401 Steering linkage . . . . .	170-1	170
	1407 Power steering gear and mounting hardware . . . . .	171-1	171
	1407 Power steering gear assembly . . . . .	172-1	172
	1410 Power steering pump support bracket. . . . .	173-1	173
	1410 Power steering pump, pulley, and mounting hardware. . . . .	174-1	174
	1410 Power steering pump, pulley, and mounting hardware. . . . .	175-1	175
	1410 Power steering pump assembly . . . . .	176-1	176
	1411 Power steering and hydro-booster hydraulic lines and fittings . . . . .	177-1	177
	1411 Power steering oil cooler, hydro-booster, and fan clutch hydraulic lines and fittings . . . . .	178-1	178
Group 15	Frame and towing attachments. . . . .	179-1	179
	1501 Frame assembly, body mount brackets, and transmission crossmember . . . . .	179-1	179
	1501 Frame assembly, body mount brackets, and transmission crossmember . . . . .	180-1	180
	1501 Air lift brackets, front upper control arm brackets, front spring seats, and mounting hardware. . . . .	181-1	181
	1501 Front suspension crossmembers, related parts, and mounting hardware. . . . .	182-1	182
	1501 Rear suspension crossmembers, related parts, and mounting hardware. . . . .	183-1	183
	1501 Upper control arm brackets, spring seats, related parts, and mounting hardware . . . . .	184-1	184
	1501 Front bumper and lifting shackle . . . . .	185-1	185
	1501 Front bumper and lifting shackle . . . . .	186-1	186
	1501 Front bumper and lifting shackle, winch. . . . .	187-1	187
	1501 Rear bumper and lifting shackle . . . . .	188-1	188
	1501 Brake protection guard (front) . . . . .	189-1	189
	1501 Brake protection guard (rear) . . . . .	190-1	190
	1503 Towing pintle assembly. . . . .	191-1	191
Group 16	Springs and shock absorbers. . . . .	192-1	192
	1601 Springs, front and rear . . . . .	192-1	192
	1604 Shock absorbers, front and rear . . . . .	193-1	193
	1605 Stabilizer bar and connecting links. . . . .	194-1	194
	1605 Rear radius rods. . . . .	195-1	195
Group 18	Body and hood . . . . .	196-1	196
	1801 Body mounting components . . . . .	196-1	196
	1801 Body assembly components, left hand. . . . .	197-1	197
	1801 Body assembly and related parts . . . . .	198-1	198
	1801 Body assembly components, right hand. . . . .	199-1	199
	1801 Body insulation and cowl assemblies . . . . .	200-1	200
	1801 Body insulation. . . . .	201-1	201
	1801 Hood assembly and mounting hardware . . . . .	202-1	202
	1801 Hood assembly grille and related parts. . . . .	203-1	203
	1801 Hood assembly ballistic grilles and related parts. . . . .	204-1	204
	1801 Left hand splash shield, radiator side armor, and hood prop rod . .	205-1	205
	1801 Right hand splash shield and radiator side armor . . . . .	206-1	206
	1801 Rear fixed doors and mounting hardware . . . . .	207-1	207
	1801 Engine access cover assembly, "A" pillar insulation, and steering wheel lock. . . . .	208-1	208
1801 Cargo bulkhead and mounting hardware . . . . .	209-1	209	

## TABLE OF CONTENTS (Cont'd)

	Page	Illus Figure
1801 Interior net assemblies, cargo bulkhead, and related items . . .	210-1	210
1801 Rear doors, M996 and M996A1 ambulance . . . . .	211-1	211
1801 Rear doors, M997, M997A1, and M997A2 ambulance . . . . .	212-1	212
1801 Bulkhead doors and related parts, M996 and M996A1 ambulance . . . . .	213-1	213
1801 Bulkhead doors and related parts, M997, M997A1, and M997A2 ambulance . . . . .	214-1	214
1801 NBC panel door and related hardware, M997, M997A1, and M997A2 ambulance . . . . .	215-1	215
1801 NBC access door and related hardware, M996 and M996A1 ambulance . . . . .	216-1	216
1801 Litter tray stowage door, M996, M996A1, M997, M997A1, and M997A2 ambulance . . . . .	217-1	217
1801 Litter tray stowage, M997, M997A1, and M997A2 ambulance . .	218-1	218
1801 Rear cover assembly, left and right hand, M996 and M996A1 ambulance . . . . .	219-1	219
1801 Cover assembly, medical stowage, left and right hand, M996 and M996A1 ambulance . . . . .	220-1	220
1801 Heater access door and related hardware, M996 and M996A1 ambulance . . . . .	221-1	221
1801 A/C and heater compartment panels and seals, M997, M997A1, and M997A2 ambulance . . . . .	222-1	222
1801 Rear door seals, M996, M996A1, M997, M997A1, and M997A2 ambulance . . . . .	223-1	223
1801 Medical stowage doors, lower heater louver, and related components, M997, M997A1, and M997A2 ambulance . . . . .	224-1	224
1802 Windshield assembly, folddown . . . . .	225-1	225
1802 Windshield assembly, ballistic . . . . .	226-1	226
1805 Interior tunnel, cowl, floor insulation, mounting components (foam), and exterior insulation . . . . .	227-1	227
1805 Insulation floorboard, front and rear . . . . .	228-1	228
1805 Floor mat cover and related hardware, M996, M996A1, M997, M997A1, and M997A2 ambulance . . . . .	229-1	229
1806 Seats and belts, front . . . . .	230-1	230
1806 Commander's seat, driver's seat, and related parts . . . . .	231-1	231
1806 Protective padding on "B" pillar for non-armored vehicles . . . .	232-1	232
1806 Protective padding on "B" pillar cover for armored vehicles . . .	233-1	233
1806 Front seatbelts, brackets, and mounting hardware . . . . .	234-1	234
1806 Seats and belts, rear . . . . .	235-1	235
1806 Seat cushions and mounting hardware, M996 and M996A1 ambulance . . . . .	236-1	236
1806 Seat frame assembly and related hardware, M996 and M996A1 ambulance . . . . .	237-1	237
1806 Attendant seat, M996, M996A1, M997, M997A1, and M997A2 ambulance . . . . .	238-1	238
1806 Rear seatbelts, brackets, and mounting hardware . . . . .	239-1	239
1808 Pioneer tool stowage tray assembly . . . . .	240-1	240
1808 First aid kit and fire extinguisher mounting brackets . . . . .	241-1	241
1808 TOW missile rack assembly and mounting hardware . . . . .	242-1	242
1808 TOW missile rack assembly, upper rack, support, and mounting hardware . . . . .	243-1	243
1808 TOW missile rack assembly, intermediate rack, and base assembly . . . . .	244-1	244
1808 Traversing unit stowage and depression stop assembly . . . . .	245-1	245

TABLE OF CONTENTS (Cont'd)

	Page	Illus Figure
1808 TOW tripod, fuel can, M16 ammo stowage brackets, telephone cable reel, combat ration straps, and mounting components . . . .	246-1	246
1808 MGS battery stowage rack and related parts. . . . .	247-1	247
1808 Night sight, bore sight collimator, and camouflage pack stowage .	248-1	248
1808 TOW night sight batteries and coolant, radiac meter, night vision goggles stowage, and TAS carry bag stowage. . . . .	249-1	249
1808 M16/M203 rifle mount and gasoline burning stove stowage . . .	250-1	250
1808 Machine gun, night sight, and ammunition stowage and related components. . . . .	251-1	251
1808 Armament tripod mount, ammunition, gun adapter mount, rear M16 rifle stowage, and related components . . . . .	252-1	252
1808 Ammunition and water can stowage trays and related components, Army. . . . .	253-1	253
1808 Ammunition and water can stowage trays and mounting hardware . . . . .	254-1	254
1808 Ammunition and water can stowage trays and related components, Air Force and Marine Corps . . . . .	255-1	255
1808 Litter straps and fasteners, right hand, M996 and M996A1 ambulance . . . . .	256-1	256
1808 Litter straps and fasteners, left hand, M996 and M996A1 ambulance . . . . .	257-1	257
1808 Oxygen bottle mounting, litter bumpers, and litter frame plugs, right hand, M996 and M996A1 ambulance . . . . .	258-1	258
1808 Oxygen bottle mounting, litter bumpers, and litter frame plugs, left hand, M996 and M996A1 ambulance . . . . .	259-1	259
1808 Oxygen bottle holddown and bracket, spine board (short) w/straps, R.H., M997, M997A1, and M997A2 ambulance . . . . .	260-1	260
1808 3-1/2 ton jack storage bracket and related items . . . . .	261-1	261
1808 I.V. bag straps and hooks, oxygen bottle stowage, and spine board strap assemblies, M996, M996A1, M997, M997A1, and M997A2 ambulance. . . . .	262-1	262
1808 Web shelf net assembly, M997, M997A1, and M997A2 ambulance . . . . .	263-1	263
1808 Attendant seat stowage hardware, M996 and M996A1 ambulance . . . . .	264-1	264
1808 Attendant seat stowage hardware, M997, M997A1, and M997A2 ambulance. . . . .	265-1	265
1810 Tailgate assembly and related parts. . . . .	266-1	266
1812 Body armor panels and mounting hardware . . . . .	267-1	267
1812 Cargo shell door, insulation, intermediate pillar, gas spring, and related components. . . . .	268-1	268
1812 Cargo shell door assembly, basic and supplemental armor . . . .	269-1	269
1812 Cargo shell mounting components . . . . .	270-1	270
1812 Cargo shell assemblies. . . . .	271-1	271
1812 Weapon station hatch assembly, latch, gunner's sling, and related components. . . . .	272-1	272
1812 Weapon station tray assembly, reinforcement tube, and related components. . . . .	273-1	273
1812 Weapon station tray mounting, TOW carrier. . . . .	274-1	274
1812 Armament pintle and panel assemblies, and related parts . . . .	275-1	275
1812 Armament pintle and panel assemblies, and related parts . . . .	276-1	276
1812 Turret support ring assembly. . . . .	277-1	277
1812 Roof and mounting components . . . . .	278-1	278

## TABLE OF CONTENTS (Cont'd)

	Page	Illus Figure
1812 Gunner's platform assembly and mounting hardware . . . . .	279-1	279
1812 Crew door assembly, front, ballistic . . . . .	280-1	280
1812 Crew door assembly, rear, ballistic . . . . .	281-1	281
1812 TOW electrical cables and mounting hardware . . . . .	282-1	282
1812 S250 shelter mounting components. . . . .	283-1	283
1812 S250 shelter tailgate mounting components . . . . .	284-1	284
1812 Litter assembly and mounting components . . . . .	285-1	285
1812 Litter assembly . . . . .	286-1	286
1812 Lower litter skids and upper litter mounting hardware, M997, M997A1, and M997A2 ambulance. . . . .	287-1	287
1812 Litter tray extension assembly, M997, M997A1, and M997A2 ambulance . . . . .	288-1	288
1812 Upper litter tray assembly, M997, M997A1, and M997A2 ambulance . . . . .	289-1	289
1812 Litter skids and tracks, M996 and M996A1 ambulance . . . . .	290-1	290
1812 Red Cross marking rear door, M996, M996A1, M997, M997A1, and M997A2 ambulance. . . . .	291-1	291
1812 Rear step mounting hardware, M996, M996A1, M997, M997A1, and M997A2 ambulance. . . . .	292-1	292
1812 Rear step assembly, M996, M996A1, M997, M997A1, and M997A2 ambulance. . . . .	293-1	293
1812 Rear step latch, striker bracket, and blackout switch mounting hardware, M996, M996A1, M997, M997A1, and M997A2 ambulance . . . . .	294-1	294
1812 Two and four litter ambulance body mounting hardware and seals, M996, M996A1, M997, M997A1, and M997A2 ambulance	295-1	295
1812 Two and four litter ambulance body mounting hardware and seals, M996, M996A1, M997, M997A1, and M997A2 ambulance	296-1	296
1812 Two and four litter ambulance body, Red Cross markings, M996, M996A1, M997, M997A1, and M997A2 ambulance . . . .	297-1	297
1812 Heater duct and grille, M996 and M996A1 ambulance . . . . .	298-1	298
1812 Heating director housing assembly, M997, M997A1, and M997A2 ambulance. . . . .	299-1	299
1812 Patient compartment heater and A/C ducts, M997, M997A1, and M997A2 ambulance. . . . .	300-1	300
1812 Hose assembly, blower to filter, M996 and M996A1 ambulance	301-1	301
1812 NBC piping for #1, 2, & 3 heaters, M997, M997A1, and M997A2 ambulance . . . . .	302-1	302
1812 NBC piping for #1, 2, & 3 heaters, M996 and M996A1 ambulance . . . . .	303-1	303
1812 NBC piping for #4 & 5 heaters, M996 and M996A1 ambulance.	304-1	304
1812 NBC piping for #4 & 5 heaters, M997, M997A1, and M997A2 ambulance . . . . .	305-1	305
1812 NBC piping for #6 & 7 heaters, M997, M997A1, and M997A2 ambulance . . . . .	306-1	306
1812 NBC blower and filter mounting hardware, M996 and M996A1 ambulance . . . . .	307-1	307
1812 NBC blower and filter mounting hardware, M997, M997A1, and M997A2 ambulance. . . . .	308-1	308
1812 NBC piping, blower box, and filter, M997, M997A1, and M997A2 ambulance . . . . .	309-1	309
1812 NBC tubing from filters to heaters, M997, M997A1, and M997A2 ambulance . . . . .	310-1	310

TABLE OF CONTENTS (Cont'd)

	Page	Illus Figure
1812 NBC heater and mounting hardware, M997, M997A1, and M997A2 ambulance . . . . .	311-1	311
1812 NBC heater and mounting hardware, M996 and M996A1 ambulance . . . . .	312-1	312
Group 20 Hoist, winch, capstan, power control unit, and power take-off . . . . .	313-1	313
2001 Winch assembly, mounting hardware, and related parts . . . . .	313-1	313
2001 Winch assembly . . . . .	314-1	314
2001 Winch control, storage box, and mounting hardware . . . . .	315-1	315
Group 22 Body, chassis, and accessory items . . . . .	316-1	316
2201 Two man crew soft top enclosure, top assembly, rear curtain, and door assemblies. . . . .	316-1	316
2201 Two man crew soft top enclosure, bow, and mounting components. . . . .	317-1	317
2201 Troop area soft top enclosure, bows, and mounting components . .	318-1	318
2201 Troop area soft top enclosure . . . . .	319-1	319
2201 Four man crew soft top enclosure, top assembly, rear curtain, and door assemblies. . . . .	320-1	320
2201 Four man crew soft top enclosure, bows, and mounting components. . . . .	321-1	321
2201 Cargo area soft top enclosure, top assembly . . . . .	322-1	322
2201 Cargo area soft top enclosure, bows, and mounting components	323-1	323
2201 Ambulance soft top enclosure, top curtain, and door assemblies. .	324-1	324
2201 Ambulance soft top enclosure, bows, and mounting components. .	325-1	325
2201 Ambulance soft top enclosure, rear bow, and mounting components . . . . .	326-1	326
2202 Windshield wiper motor, wiper assembly, and washer bottle . .	327-1	327
2202 Rearview mirror and mounting hardware . . . . .	328-1	328

VOLUME 2 OF 2

2202 Split rearview mirror and mounting hardware . . . . .	329-1	329
2202 Reflectors . . . . .	330-1	330
2202 Diverter assembly, defroster, and heater ducting. . . . .	331-1	331
2202 A2 diverter assembly, defroster, heater ducting, and radio brackets . . . . .	332-1	332
2202 Heater assembly, water valve, and controls. . . . .	333-1	333
2202 Heater fuel lines, filter to tank, M996, M996A1, M997, M997A1, and M997A2 ambulance . . . . .	334-1	334
2202 Fuel lines, personnel heater to fuel filter, M996 and M996A1 ambulance . . . . .	335-1	335
2202 Fuel lines, personnel heater to fuel filter, M997, M997A1, and M997A2 ambulance . . . . .	336-1	336
2202 Personnel heater assembly and attaching hardware, M996 and M996A1 ambulance. . . . .	337-1	337
2202 Antenna and intercom cables and mounting hardware, M997, M997A1, and M997A2 ambulance. . . . .	338-1	338
2202 Antenna and intercom cables and mounting hardware, M996 and M996A1 ambulance. . . . .	339-1	339
2202 Antenna mount and mounting hardware, M996 and M996A1 ambulance . . . . .	340-1	340
2202 Antenna mount and mounting hardware, M997, M997A1, and M997A2 ambulance. . . . .	341-1	341
2202 Heater blower assembly, M996 and M996A1 ambulance . . . . .	342-1	342
2202 Heater, filter, and attaching hardware, M997, M997A1, and M997A2 ambulance. . . . .	343-1	343



## TABLE OF CONTENTS (Cont'd)

	Page	Illus Figure
2202 Air intake filter, M996 and M996A1 ambulance . . . . .	344-1	344
2202 Heater assembly, multifuel, B-model, M996, M996A1, M997, M997A1, and M997A2 ambulance. . . . .	345-1	345
2202 Heater grille, exhaust pipe, and mounting hardware, M996 and M996A1 ambulance. . . . .	346-1	346
2202 Heater grille, exhaust pipe, and mounting hardware, M997, M997A1, and M997A2 ambulance. . . . .	347-1	347
2202 Heater assembly, multifuel, A-model, M997, M997A1, and M997A2 ambulance. . . . .	348-1	348
2202 Heater component bracket assembly, B-model, M996, M996A1, M997, M997A1, and M997A2 ambulance . . . . .	349-1	349
2202 Burner assembly, B-model, M996, M996A1, M997, M997A1, and M997A2 ambulance. . . . .	350-1	350
2202 Burner assembly, A-model, M997, M997A1, and M997A2 ambulance . . . . .	351-1	351
2202 Sun visor assembly and mounting hardware . . . . .	352-1	352
2202 Ambulance spreader assembly . . . . .	353-1	353
2210 Data plates, dash panel . . . . .	354-1	354
2210 Data plates, battery cable and slave receptacle . . . . .	355-1	355
2210 Data plates, surge tank, fan shroud, and cook stove. . . . .	356-1	356
2210 Data plates, generator, transfer case, and engine container . . .	357-1	357
2210 Data plates, winch. . . . .	358-1	358
2210 Data plates, TOW carrier. . . . .	359-1	359
2210 Data plates, TOW carrier. . . . .	360-1	360
2210 Data plates, sights, traversing unit, night vision goggles, and radiac meter. . . . .	361-1	361
2210 Data plates and identification tags, M996, M996A1, M997, M997A1, and M997A2 ambulance. . . . .	362-1	362
Group 33 Special purpose kits . . . . .	363-1	363
3301 Engine shipping container assembly. . . . .	363-1	363
3303 Arctic kit, fuel injection pump, engine gaskets, and CDR tube . .	364-1	364
3303 Arctic kit, pan cover and heater tube . . . . .	365-1	365
3303 Arctic kit, control box, gas cap, fuel pump, and fuel lines . . . .	366-1	366
3303 Arctic kit, control box assembly . . . . .	367-1	367
3303 Arctic kit, heater assembly, plenum assembly, and related components. . . . .	368-1	368
3303 Arctic kit, battery box components, insulation, and control box connector . . . . .	369-1	369
3303 Arctic kit, diverter box, defroster, heater ducting, and radio rack bracket . . . . .	370-1	370
3303 Arctic kit, heater duct assembly . . . . .	371-1	371
3303 Arctic kit, diverter box, ducting, insulation, and radio mounting brackets. . . . .	372-1	372
3303 Arctic kit, two man crew, bow, and mounting components . . . .	373-1	373
3303 Arctic kit, two man crew curtain fasteners . . . . .	374-1	374
3303 Arctic kit, two man crew, top curtain, rear curtain, and door assemblies . . . . .	375-1	375
3303 Arctic kit, four man crew, top enclosure, bows, and mounting components. . . . .	376-1	376
3303 Arctic kit, door hinges, and curtain channels. . . . .	377-1	377
3303 Arctic kit, four man crew, top curtain, rear curtain, and door assemblies . . . . .	378-1	378
3303 Swingfire heater kit and related parts . . . . .	379-1	379
3033 Swingfire heater kit, circuit breaker and related parts. . . . .	380-1	380

TABLE OF CONTENTS (Cont'd)

	Page	Illus Figure
3303 Swingfire heater kit, harness assemblies . . . . .	381-1	381
3303 Two door seat and floor covers . . . . .	382-1	382
3303 Cargo floor cover and harness assembly . . . . .	383-1	383
3303 Winterization kit, fuel pump and attaching hardware . . . . .	384-1	384
3303 Fuel pump tube assembly . . . . .	385-1	385
3303 Winterization kit, fuel line and jumper cable. . . . .	386-1	386
3303 Winterization kit, heater and exhaust diverter assembly . . . . .	387-1	387
3303 Winterization kit, control box, filter, and cover assembly . . . . .	388-1	388
3303 Seat support assemblies and mounting hardware . . . . .	389-1	389
3303 Step assembly, support assembly, and mounting hardware . . . . .	390-1	390
3303 Top plate support and attaching hardware . . . . .	391-1	391
3303 Fuel can bracket, antenna mounting bracket, and composite light housing mounting hardware. . . . .	392-1	392
3303 Mounting plates and ventilator exhaust ducting . . . . .	393-1	393
3303 Screw caps and winterization instruction plate . . . . .	394-1	394
3303 Top cover assembly and mounting hardware. . . . .	395-1	395
3303 Wiring harness channel and hardware . . . . .	396-1	396
3303 End closures, door assembly, and mounting hardware . . . . .	397-1	397
3305 Deep water fording kit, intake and exhaust systems . . . . .	398-1	398
3305 Deep water fording kit, selector valve, sensor cup, and vent lines. . . . .	399-1	399
3305 Deep water fording kit, hydro-boost vent line, engine and transmission dipstick, and tube assemblies. . . . .	400-1	400
3305 Supplemental deep water fording kit . . . . .	401-1	401
3307 Troop seat kit, safety strap, and mounting hardware. . . . .	402-1	402
3307 Troop seat assembly, left and right. . . . .	403-1	403
3307 Alternator, 100 AMP kit (PRESTOLITE) . . . . .	404-1	404
3307 Alternator, 100 AMP kit (NIEHOFF) . . . . .	405-1	405
3307 Alternator, 100 AMP (PRESTOLITE) . . . . .	406-1	406
3307 Alternator, 100 AMP (NIEHOFF). . . . .	407-1	407
3307 Alternator, 200 AMP kit . . . . .	408-1	408
3307 Communications kit, radio rack assembly, and mounting hardware, AN/GRC-160 and TSEC/KY-57. . . . .	409-1	409
3307 Communications kit, radio cables, AN/GRC-160, AN/VRC-46, and TSEC/KY-57 . . . . .	410-1	410
3307 Communications kit, radio rack assembly, and mounting hardware, AN/GRC-160 and TSEC/KY-57, TOW carrier. . . . .	411-1	411
3307 Communications kit, radio cables, AN/GRC-160, AN/VRC-46, and TSEC/KY-57, TOW carrier . . . . .	412-1	412
3307 Communications kit, radio rack assembly, AN/VRC-47 and (2) TSEC/KY-57 assemblies . . . . .	413-1	413
3307 Communications kit, radio cables, AN/VRC-47 and (2) TSEC/KY-57 assemblies . . . . .	414-1	414
3307 Communications kit, radio rack assembly, AN/VRC-49 and (2) TSEC/KY-57 assemblies . . . . .	415-1	415
3307 Communications kit, radio cables, AN/VRC-49 and (2) TSEC/KY-57 assemblies . . . . .	416-1	416
3307 Communications kit, radio rack assembly. . . . .	417-1	417
3307 Communications kit, radio rack assembly mounting hardware, AN/VRC-46. . . . .	418-1	418
3307 Communications kit, radio rack assembly mounting hardware, (2) AN/VRC-46 . . . . .	419-1	419
3307 Communications kit, radio rack assembly mounting hardware, (3) AN/VRC-46 . . . . .	420-1	420
3307 Communications kit, radio rack assembly mounting hardware, AN/VRC-47. . . . .	421-1	421

## TABLE OF CONTENTS (Cont'd)

	Page	Illus Figure
3307 Communications kit, radio rack assembly mounting hardware, AN/VRC-48 . . . . .	422-1	422
3307 Communications kit, radio rack assembly mounting hardware, AN/VRC-49 . . . . .	423-1	423
3307 Communications kit, radio cable, main power . . . . .	424-1	424
3307 Communications kit, radio cables, AN/VRC-47 and AN/VRC-48 . . . . .	425-1	425
3307 Communications kit, radio cables, AN/VRC-46, (2) AN/VRC-46, (3) AN/VRC-46, AN/VRC-47, AN/VRC-48, and AN/VRC-49 . . . . .	426-1	426
3307 Communications kit, radio cables, (2) AN/VRC-46, (3) AN/VRC-47, and AN/VRC-49 . . . . .	427-1	427
3307 Communications kit, radio cables, (3) AN/VRC-46 . . . . .	428-1	428
3307 81 MM mortar kit, container assembly, and stowage rack . . . . .	429-1	429
3307 81 MM mortar kit, equipment rack assembly, barrel stowage bracket, and bipod stowage tray assembly . . . . .	430-1	430
3307 Traversing bar kit . . . . .	431-1	431
3307 Rearview mirror mounting kit . . . . .	432-1	432
3307 Cargo barrier extension kit . . . . .	433-1	433
3307 Slave receptacle kit . . . . .	434-1	434
3307 Slave receptacle with power cable assembly kit . . . . .	435-1	435
3307 Power steering oil cooler kit . . . . .	436-1	436
3307 Brushguard kit (Basic and A1 Series) . . . . .	437-1	437
3307 Kit, S250 shelter mounting components . . . . .	438-1	438
3307 Kit, S250 shelter tailgate mounting components . . . . .	439-1	439
3307 Kit, camouflage rack and stowage rack assembly . . . . .	440-1	440
3307 Kit, prime mover, lt. howitzer, 105MM L119, front bumper . . . . .	441-1	441
3307 Kit, prime mover, lt. howitzer, 105MM L119, rear bumper . . . . .	442-1	442
3307 Kit, prime mover, lt. howitzer, 105MM L119, winch . . . . .	443-1	443
3307 Kit, prime mover, lt. howitzer, 105MM L119, winch control and storage box . . . . .	444-1	444
3307 Kit, prime mover, lt. howitzer, 105MM L119, trailer receptacle and body wiring harness . . . . .	445-1	445
3307 Kit, prime mover, lt. howitzer, 105MM L119, ammo rack and sight boxes stowage . . . . .	446-1	446
3307 Kit, prime mover, lt. howitzer, 105MM L119, telephone, remote, and tripod stowage . . . . .	447-1	447
3307 Kit, prime mover, lt. howitzer, 105MM L119, fuel can, water can, section chest, and spade stowage . . . . .	448-1	448
3307 Kit, prime mover, lt. howitzer, 105MM L119, G.D.U. and G.D.U. battery stowage . . . . .	449-1	449
3307 Kit, prime mover, lt. howitzer, 105MM L119, aiming post and cable reel stowage . . . . .	450-1	450
3307 Kit, prime mover, lt. howitzer, 105MM L119, pioneer tool stowage tray hardware and parking brake hardware . . . . .	451-1	451
3307 Kit, towed vulcan system . . . . .	452-1	452
3307 Kit, pintle extension . . . . .	453-1	453
3307 Kit, rear seat assembly . . . . .	454-1	454
3307 Kit, man portable air-defense system (MANPADS) . . . . .	455-1	455
3307 Kit, 9,000 lb winch . . . . .	456-1	456
3307 Kit, 9,000 lb winch . . . . .	457-1	457
3307 9,000 lb winch assembly . . . . .	458-1	458
3307 Modification kit, sun visor . . . . .	459-1	459
3307 Modification kit, windshield retainer . . . . .	460-1	460
3307 Left rearview mirror relocation kit . . . . .	461-1	461
3307 Brushguard kit . . . . .	462-1	462
3307 Underbody protection kit with and without winch . . . . .	463-1	463

TABLE OF CONTENTS (Cont'd)

	Page	Illus Figure
3307 Underbody protection kit, transercase, fuel tank shields, and sway bar link nuts . . . . .	464-1	464
3307 Cover, access cargo floor modification kit . . . . .	465-1	465
3307 FR12 refrigerant parts kit . . . . .	466-1	466
3307 R-12 to FR12 refrigerant conversion retrofit kit. . . . .	467-1	467
3307 Hand throttle control kit . . . . .	468-1	468
3307 10,500 lb hydraulic winch accessory kit. . . . .	469-1	469
3307 10,500 lb hydraulic winch winch accessory kit. . . . .	470-1	470
3307 10,500 lb hydraulic winch accessory kit. . . . .	471-1	471
3307 100 AMP dual voltage alternator and regulator mounting hardware kit. . . . .	472-1	472
3307 100/200 AMP dual voltage alternator and regulator mounting hardware kit . . . . .	473-1	473
3307 100/200 AMP dual voltage alternator wiring harness. . . . .	474-1	474
3307 200 AMP dual voltage alternator and regulator mounting hardware kit. . . . .	475-1	475
3307 400 AMP alternator kit . . . . .	476-1	476
3307 Power steering pump and hoses-400 AMP alternator kit . . . . .	477-1	477
3307 Speedometer cable assembly-400 AMP alternator kit. . . . .	478-1	478
3307 Dipstick and dummy connector plug-400 AMP alternator kit . .	479-1	479
3307 400 AMP alternator wiring harness cable assemblies. . . . .	480-1	480
3307 Buss assembly-400 AMP alternator kit. . . . .	481-1	481
3307 Tachometer parts kit. . . . .	482-1	482
3307 Tachometer parts kit. . . . .	483-1	483
3307 Tachometer parts kit. . . . .	484-1	484
3307 Precision Lightweight Global Positioning System Receiver (PLGR) . . . . .	485-1	485
3307 Kit, intercom bracket. . . . .	486-1	486
3307 Kit, rear hatch support . . . . .	487-1	487
<b>Group 47</b> Gauges, weighing, and measuring devices . . . . .	488-1	488
4701 Speedometer, speedometer drive, and related parts . . . . .	488-1	488
4702 Air restriction indicator assembly. . . . .	489-1	489
<b>Group 52</b> Refrigeration, air conditioner, heater, and air conditioning components. . . . .	490-1	490
5203 Air conditioner compressor and mounting hardware, M997 and M997A1 ambulance. . . . .	490-1	490
5203 Air conditioner compressor assembly, M997 and M997A1 ambulance . . . . .	491-1	491
5217 Air conditioner lines and fittings, M997, M997A1, and M997A2, ambulance . . . . .	492-1	492
5217 Air conditioner condenser and evaporator lines, M997, M997A1, and M997A2 ambulance. . . . .	493-1	493
5230 Heater and air conditioning condenser, M997, M997A1, and M997A2 ambulance. . . . .	494-1	494
5230 Heater and air conditioning condenser, M997, M997A1, and M997A2 ambulance. . . . .	495-1	495
5241 Air conditioning evaporator and mounting hardware, M997, M997A1, and M997A2 ambulance. . . . .	496-1	496
5243 Evaporator blower motor assembly covers, M997, M997A1, and M997A2 ambulance. . . . .	497-1	497
5243 Evaporator blower motor assembly, M997, M997A1, and M997A2 ambulance . . . . .	498-1	498

TABLE OF CONTENTS (Cont'd)

		Page	Illus Figure
Group 94	Repair parts kits. . . . .	Kits 1	
	9401 Repair parts kits. . . . .	Kits-1	
Group 95	Bulk material. . . . .	Bulk-1	
	9501 Bulk. . . . .	Bulk-1	
Section III	SPECIAL TOOLS LIST. . . . .	499-1	
Group 26	Tools and test equipment . . . . .	499-1	499
	2604 Special tools, drive belts and transmission . . . . .	499-1	499
	2604 Special tools, transmission. . . . .	500-1	500
	2604 Special tools, transfer case. . . . .	501-1	501
	2604 Special tools, axle differential. . . . .	502-1	502
	2604 Special tools, geared hub and steering . . . . .	503-1	503
	2604 Special tools, steering pump, body, and speedometer drive. . . . .	504-1	504
	2604 Special tools, multipurpose. . . . .	505-1	505
	2604 Special tools, air conditioner compressor. . . . .	506-1	506
	2604 Special tools, air conditioner compressor. . . . .	507-1	507
	2604 Special tools, air conditioner compressor. . . . .	508-1	508
	2604 Special tools, air conditioner compressor tool kit. . . . .	509-1	509
	2604 Special tools, transmission, transfer case, and engine A2. . . . .	510-1	510
	2604 Special tools, transmission, transfer case, and engine A2. . . . .	511-1	511
	2604 Pinion setting kit. . . . .	512-1	512
Section IV	CROSS-REFERENCE INDEXES. . . . .	I-11	
	National Stock Number Index . . . . .	I-1	
	Part Number Index. . . . .	I-100	

# UNIT, DIRECT SUPPORT, AND GENERAL SUPPORT MAINTENANCE REPAIR PARTS AND SPECIAL TOOLS LIST

## Section I. INTRODUCTION

### 1. Scope.

This Repair Parts and Special Tools List (RPSTL) lists and authorizes spares and repair parts; special tools; Test, Measurement, and Diagnostic Equipment (TMDE); and other special support equipment required for performance of unit, direct support, and general support maintenance of the 1-1/4 ton, 4x4, M998, M998A1, and M998A2 series vehicles. It authorizes the requisitioning, issue, and disposition of spares, repair parts, and special tools as indicated by the Source, Maintenance, and Recoverability (SMR) codes.

### 2. General.

This RPSTL is divided into the following sections:

**a. Section II. Repair Parts List.** A list of spares and repair parts authorized for use in the performance of maintenance. The list also includes parts which must be removed for replacement of the authorized parts. Parts lists are composed of functional groups in ascending alphanumeric sequence, with the parts in each group listed in ascending figure and item number sequence. Bulk materials are listed in item name sequence. Repair parts kits are listed separately in their own functional group within section II. Repair parts for reparable special tools are also listed in this section. Items listed are shown on the associated illustration(s)/figure(s).

**b. Section III. Special Tools List.** A list of special tools, special TMDE, and other special support equipment authorized by this RPSTL (as indicated by Basis of Issue (BOI) information in DESCRIPTION AND USABLE ON CODE column) for the performance of maintenance.

**c. Section IV. National Stock Number and Part Number Index.** A list, in ascending National Item Identification Number (NIIN) (last nine numerals) sequence, of all National stock numbered items appearing in the listing, followed by a list, in alphanumeric sequence, of all part numbers appearing in the listings. National stock numbers and part numbers are cross-referenced to each illustration figure and item number appearance.

### 3. Explanation of Columns (Sections II and III).

**a. Item No. (Column (1)).** Indicates the number used to identify items called out in the illustration.

**b. SMR Code (Column (2)).** The Source, Maintenance, and Recoverability (SMR) code is a 5-position code containing supply/requisitioning information, maintenance category authorization criteria, and disposition instruction, as shown in the following breakout:

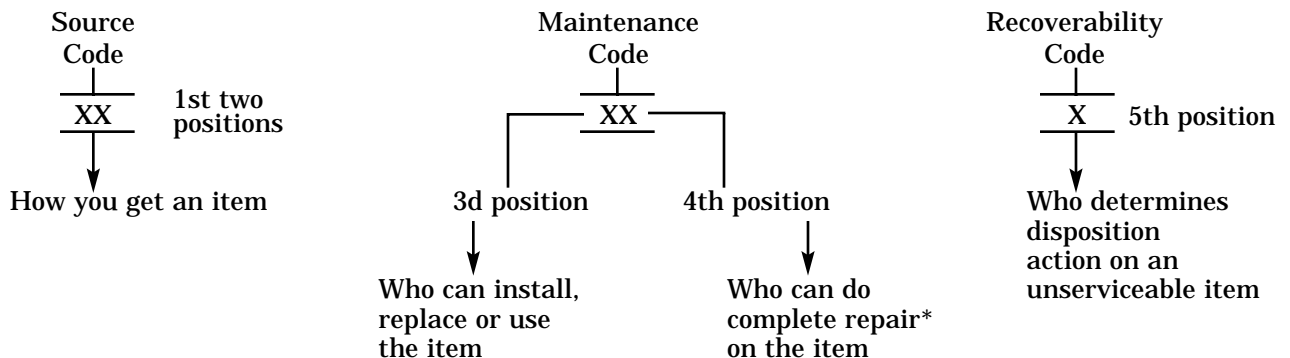

\* Complete Repair: Maintenance capacity, capability, and authority to perform all corrective maintenance tasks of the "repair" function in a use/user environment in order to restore serviceability to a failed item.

**(1) Source Code.** The source code tells you how to get an item needed for maintenance, repair, or overhaul of an end item/equipment. Explanations of source codes follow:

Code	Explanation
PA	Stocked items: use the applicable NSN to request/requisition items with these source codes. They are authorized to the category indicated by the code entered in the 3d position of the SMR code.  ** NOTE: Items coded PC are subject to deterioration.
PB	
PC**	
PD	
PE	
PG	
KD	Items with these codes are not to be requested/requisitioned individually. They are part of a kit which is authorized to the maintenance category indicated in the 3d position of the SMR code. The complete kit must be requisitioned and applied.
KF	
KB	
MO- (Made at Unit Level)	Items with these codes are not to be requested/requisitioned individually. They must be made from bulk material which is identified by the part number in the DESCRIPTION AND USABLE ON CODE (UOC) column and listed in the bulk material group of the repair parts list in the RPSTL. If the item is authorized to you by the 3d position code of the SMR code, but the source code indicates it is made at a higher level, order the item from the higher level of maintenance.
MF- (Made at DS Level)	
MH- (Made at GS Level)	
ML- (Made at Specialized Repair Activity (SRA))	
MD- (Made at Depot)	
AO- (Assembled by Unit Level)	Items with these codes are not to be requested/requisitioned individually. The parts that make up the assembled item must be requisitioned or fabricated and assembled at the level of maintenance indicated by the source code. If the 3d position code of the SMR code authorizes you to replace the item, but the source code indicates the item is assembled at a higher level, order the item from the higher level of maintenance.
AF- (Assembled by DS Level)	
AH- (Assembled by GS Level)	
AL- (Assembled by SRA)	
AD- (Assembled by Depot)	
XA-	Do not requisition an XA-coded item. Order its next higher assembly. (Also, refer to the note below.)
XB-	If an XB-coded item is not available from salvage, order it using the CAGEC and part number given.
XC-	Installation drawing, diagram, instruction sheet, field service drawing, that is identified by manufacturer's part number.
XD-	Item is not stocked. Order an XD-coded item through normal supply channels using the CAGEC and part number given if no NSN is available.

**NOTE**

Cannibalization or controlled exchange, when authorized, may be used as a source of supply for items with the above source codes, except for those source-coded XA.

**(2) Maintenance Code.** Maintenance codes tell you the level(s) of maintenance authorized to USE and REPAIR support items. The maintenance codes are entered in the 3d and 4th positions of the SMR code as follows:

**(a)** The maintenance code entered in the 3d position tells you the lowest maintenance level authorized to remove, replace, and use an item. The maintenance code entered in the 3d position will indicate authorization to one of the following levels of maintenance.

Code	Application/Explanation
C	- Crew or operator maintenance done within unit maintenance.
O	- Unit level can remove, replace, and use the item.
F	- Direct support level can remove, replace, and use the item.
H	- General support level can remove, replace, and use the item.
L	- Specialized repair activity can remove, replace, and use the item.
D	- Depot level can remove, replace, and use the item.

**(b)** The maintenance code entered in the 4th position tells you whether or not the item is to be repaired and identifies the lowest maintenance level with the capability to do complete repair (i.e., perform all authorized repair functions). (NOTE: Some limited repair may be done on the item at a lower level of maintenance if authorized by the Maintenance Allocation Chart (MAC) and SMR codes.) This position will contain one of the following maintenance codes:

Code	Application/Explanation
O	– Unit is the lowest level that can do complete repair of the item.
F	– Direct support is the lowest level that can do complete repair of the item.
H	– General support is the lowest level that can do complete repair of the item.
L	– Specialized repair activity (designate the specialized repair activity) is the lowest level that can do complete repair of the item.
D	– Depot is the lowest level that can do complete repair of the item.
Z	– Nonreparable. No repair is authorized.
B	– No repair is authorized. (No parts or special tools are authorized for the maintenance of a B-coded item.) However, the item may be reconditioned by adjusting, lubricating, etc., at the user level.

**(3) Recoverability Code.** Recoverability codes are assigned to items to indicate the disposition action on unserviceable items. The recoverability code is entered in the 5th position of the SMR code as follows:

Recoverability Code	Application/Explanation
Z	– Nonreparable item. When unserviceable, condemn and dispose of the item at the level of maintenance shown in 3d position of SMR code.
O	– Repairable item. When uneconomically repairable, condemn and dispose of the item at unit level.
F	– Repairable item. When uneconomically repairable, condemn and dispose of the item at the direct support level.
H	– Repairable item. When uneconomically repairable, condemn and dispose of the item at the general support level.
D	– Repairable item. When beyond lower level repair capability, return to depot. Condemnation and disposal of item not authorized below depot level.
L	– Repairable item. Condemnation and disposal not authorized below SRA.
A	– Item requires special handling or condemnation procedures because of specific reasons (e.g., precious metal content, high dollar value, critical material, or hazardous material). Refer to appropriate manuals/directives for specific instructions.

**c. National Stock Number (Column 3).** This column indicates the National Stock Number (NSN) assigned to the item. Use the NSN for requests/requisitions.

**d. CAGE Code (Column 4).** The Commercial and Government Entity Code (CAGEC) is a 5-digit numeric code which is used to identify the manufacturer, distributor, or Government agency, etc., that supplies the item.

**e. Part Number (Column 5).** Indicates the primary number used by the manufacturer (individual, company, firm, corporation, or Government activity), which controls the design and characteristics of the item by means of its engineering drawings, specifications standards, and inspection requirements to identify an item or range of items.



**f. Description and Usable on Codes (UOC) (Column (6)).** This column includes the following information:

- (1) The Federal item name and, when required, a minimum description to identify the item.
- (2) Items that are included in kits and sets are listed below the name of the kit or set.
- (3) Spare/repair parts that make up an assembled item are listed immediately following the assembled item line entry.
- (4) Part numbers for bulk materials are referenced in this column in the line item entry for the item to be manufactured/fabricated.
- (5) When the item is not used with all serial numbers of the same model, the effective serial numbers are shown on the last line(s) of the description (before UOC).
- (6) The usable on code, when applicable (refer to paragraph 5, Special Information).
- (7) In the Special Tools List section, the Basis of Issue (BOI) appears as the last line(s) in the entry for each special tool, special TMDE, and other special support equipment. When density of equipment supported exceeds density spread indicated in the basis of issue, the total authorization is increased proportionately.
- (8) The statement END OF FIGURE appears just below the last item description in column 6 for a given figure in both section II and section III.

**g. QTY (Column (7)).** The Quantity Incorporated in Unit (QTY INC IN UNIT) indicates the quantity of the item used in the breakout shown on the illustration figure, which is prepared for a functional group, subfunctional group, or an assembly. A "V" appearing in this column in place of a quantity indicates that no specific quantity is applicable (e.g., shims, spacers).

4. Explanation of Columns (Section IV).

**a. National Stock Number (NSN) Index.**

- (1) **Stock number column.** This column lists the NSN by National Item Identification Number (NIIN)  
NSN

sequence. The NIIN consists of the last nine digits of the NSN (i.e., 5305-01-674-1467). When using this column  
\_\_\_\_\_ NIIN

to locate an item, ignore the first 4 digits of the NSN. However, the complete NSN should be used when ordering items by stock number.

- (2) **Fig. column.** This column lists the number of the figure where the item is identified/located. The figures are in numerical order in section II and section III.

- (3) **Item column.** The item number identifies the item associated with the figure listed in the adjacent FIG. column. This item is also identified by the NSN listed on the same line.

**b. Part number Index.** Part numbers in this index are listed by part number in ascending alpha-numeric sequence (i.e., vertical arrangement of letter and number combination which places the first letter or digit of each group in order A through Z, followed by the numbers 0 through 9 and each following letter or digit in like order).

- (1) **CAGEC column.** The Commercial and Government Entity Code (CAGEC) is a 5-digit numeric code used to identify the manufacturer, distributor, or Government agency, etc., that supplies the item.

- (2) **Part number column.** Indicates the primary number used by the manufacturer (individual, company, firm, corporation, or Government activity), which controls the design and characteristics of the item by means of its engineering drawings, specifications standards, and inspection requirements to identify an item or range of items.

- (3) **Stock number column.** This column lists the NSN for the associated part number and manufacturer identified in the PART NUMBER and CAGEC columns to the left.

**(4) Fig. column.** This column lists the number of the figure where the item is identified/located in section II and section III.

**(5) Item column.** The item number is that number assigned to the item as it appears in the figure referenced in the adjacent figure number column.

5. Special Information.

**a. Usable on Code.** The Usable on Code appears in the lower left corner of the DESCRIPTION column heading. Usable on Codes are shown as UOC: . . . . . in the DESCRIPTION column (justified left) on the first line of applicable item description/nomenclature. Uncoded items are applicable to all models and title description will indicate all M998, M998A1, and M998A2 models. Identification of the Usable on Codes used in the RPSTL are:

Code	Used On	Code	Used On	Code	Used On
AVY	M1097A1	B16	M996A1	H16	M996
A11	M966A1	B17	M1025A1	H17	M1025
A13	M998A1	B18	M1026A1 W/W	H18	M1026 W/W
A14	M1038A1 W/W	B20	M1035A2	H20	M1035
A15	M997A1	B24	M1045A2	H21	M1037
A20	M1035A1	B25	M1043A2	H24	M1045
A24	M1045A1	C17	M1025A2	H25	M1043
A25	M1043A1	HVY	M1097	H26	M1044 W/W
A26	M1044A1 W/W	H11	M966	H27	M1046 W/W
A27	M1046A1 W/W	H13	M998	H28	M1042 W/W
BVY	M1097A2	H14	M1038 W/W	MMM	M1121
B15	M997A2	H15	M997	NNN	M1123
<b>Code</b>	<b>Used On</b>				
HPM	M1097 W/W and L119 Prime Mover Kit				
SLT	M1097 W/W and S250 Shelter Kit				
KTV	M1097 W/W and Towed Vulcan System Kit				

**b. Fabrication Instructions.** Bulk materials required to manufacture items are listed in the bulk material functional group of this RPSTL. Part numbers for bulk materials are also referenced in the description column of the line item entry for the item to be manufactured/fabricated. Detailed fabrication instructions for items source-coded to be manufactured or fabricated are found in TM 9-2320-280-20, TM 9-2320-280-34, and TM 9-2815-237-34.

**c. Assembly Instructions.** Detailed assembly instructions for items source-coded to be assembled from component spare/repair parts are found in TM 9-2320-280-20 and TM 9-2320-280-34. Items that make up the assembly are listed immediately following the assembly item entry, or reference is made to an applicable figure.

**d. Kits.** Line item entries for repair parts kits appear in LCN group kits in section II.

**e. Index Numbers.** Items which have the word BULK in the figure column will have an index number shown in the item number column. This index number is a cross-reference between the National Stock Number/Part Number Index and the bulk material list in section II.

**f. Associated Publications.** The publications listed below pertain to the 1-1/4 ton, 4x4, M998, M998A1, and M998A2 series vehicles and their components:

TM 9-2320-280-10	Operator's Manual
TM 9-2320-280-10HR	Hand Receipt, Operator's Manual
TM 9-2320-280-20	Unit Maintenance Manual
TM 9-2320-280-34	Direct Support and General Support Maintenance Manual
TM 9-2815-237-34	Direct Support and General Support Engine Maintenance Manual
TM 9-2815-237-34P	Direct Support and General Support Maintenance Repair Parts and Special Tools List

DMWR 9-2520-527	Depot Maintenance Work Requirements, Transmission, Automatic
DMWR 9-2520-528	Depot Maintenance Work Requirements, Transfer, Constant Drive
DMWR 9-2520-529	Depot Maintenance Requirements, Differential, Locking
DMWR 9-2815-237	Depot Maintenance Work Requirements, Engine

**g. Illustrations.** Item numbers on illustrations have been assigned in clockwise sequence, starting at the 11 o'clock position (upper left).

**h. USMC SMR Codes.** There are cases in TM 9-2320-280-24P where the USMC uses different SMR codes than the Army. The list provided below identifies these differences and is for Marine Corps use only. This list is the only place in TM 9-2320-280-24P where these differences appear. It is recommended that Marine Corps technicians make the appropriate annotations within the body of this technical manual. All items w/PB, PC, PE, PF, or PG in the first two positions of the SMRC will be PA for the USMC.

**FOR USMC USE ONLY**

<b>FIG NO</b>	<b>ITEM NO</b>	<b>MFG P/N</b>	<b>ITEM NAME</b>	<b>MARINE CORPS PECULIAR SMRC</b>
5	2	19111	COOLER, LUBRICATING	PAOHH
26	1	DA-875700-D	RADIATOR, ENGINE COOL	PAOHH
35	6	10929868	GENERATOR, ENGINE	PAOHH
39	2	95513	•SEAL, PLAIN	PAHZZ
39	3	95510	•BEARING, UNIT, BALL	PAHZZ
39	4	100276	•SEAL, PLAIN	PAHZZ
39	5	95552	•COVER, ACCESS	PAHZZ
39	6	MS51849-64	•SCREW, MACHINE	PAHZZ
39	7	4465	•SCREW, MACHINE	PAHZZ
39	11	MS51967-9	•NUT, HEXAGON	PAHZZ
39	12	SP1548-1	•WASHER, FLAT	PAHZZ
39	13	95605	•WASHER, FLAT	PAHZZ
39	14	95467	•INSULATOR, PLATE	PAHZZ
39	15	96745	•SPACER, SLEEVE	PAHZZ
39	16	96520	•ROTOR ASSEMBLY	PAHZZ
39	17	95483	•SEAL, PLAIN	PAHZZ
39	18	77960	•BUSHING, SLEEVE	PAHZZ
39	19	96846	•HOUSING ASSEMBLY	XAHZZ
39	20	96764	•BEARING, ROLLER	PAHZZ
39	21	95972	•IMPELLER, FAN	PAHZZ
39	22	74107	•NUT, SELF-LOCKING	PAHZZ
39	23	1869	•KEY, WOODRUFF	PAHZZ
39	24	95469	•BOLT, MACHINE	PAHZZ
39	25	1459-254	•WASHER, LOCK	PAHZZ
39	26	95498	•GASKET	PAHZZ
39	27	96259	•INSULATOR, TERMINAL	PAHZZ
39	28	A022096282	•STATOR	PAHZZ
39	31	95504	•SCREW, HEXAGON HEAD	PAHZZ
39	38	96154	•LEAD ASSEMBLY	PAHZZ
39	39	96247	•PLATE, MENDING	XFHZZ
39	40	96160	•LEAD ASSEMBLY	PAHZZ
39	47	13981	•SCREW, MACHINE	PAHZZ
39	48	7266	•WASHER, LOCK	PAHZZ
39	49	100210	•COVER, ACCESS	PAHZZ
39	50	96180	•SPACER, SLEEVE	PAHZZ
39	51	96162	•LEAD ASSEMBLY	PAHZZ
39	53	96756	•RECTIFIER ASSEMBLY	PAHZZ

FIG NO	ITEM NO	MFG P/N	ITEM NAME	MARINE CORPS PECULIAR SMRC
39	54	95484	•STUD, CONTACT	PAHZZ
39	57	Z106005179	•SCREW, MACHINE	PAHZZ
39	58	Z116 096169	•HOLDER, FUSE	PAHZZ
39	64	96156	•LEAD ASSEMBLY	PAHZZ
39	65	96158	•LEAD ASSEMBLY	PAHZZ
39	66	A010095461	•BRUSH ASSEMBLY	PAHZZ
39	67	96172	•GASKET	PAHZZ
39	68	99479	•HOLDER	PAHZZ
39	69	99514	•PACKING, PREFORMED	PAHZZ
39	70	96769	•PLATE, RETAINING	PAHZZ
39	71	96768	•GASKET	PAHZZ
39	72	95515	•COVER	PAHZZ
39	73	95516	•SPACER	PAHZZ
39	74	R055101472	•CIRCUIT CARD ASSEMBLY	PAHZZ
39	75	95965	•INSULATOR, WASHER	PAHZZ
39	76	36912	•WASHER, FLAT	PAHZZ
39	77	36895	•WASHER, LOCK	PAHZZ
39	78	23304	•SCREW, MACHINE	PAHZZ
43	1	8MA-3010AS	ROTOR, GENERATOR	PAHZZ
43	2	AMA-75	•NUT	KFHZZ
43	3	AMA-74	•WASHER, FLAT	KFHZZ
43	4	MS35756-6	•KEY, WOODRUFF	KFHZZ
43	5	14-273	END BELL, ELECTRICAL	PAHZZ
43	6	AMA-1014A	•RETAINER ASSEMBLY	KFHZZ
43	7	XA-1316	••SEAL KIT	PFHZZ
43	8	XA-744AV	•SPRING, SEAL BEARING	KFHZZ
43	9	AMA-66A	•SPACER	KFHZZ
43	10	XA-744AY	•O-RING	KFHZZ
43	11	AMA-90	•WASHER	KFHZZ
43	12	X-4070	•BEARING, BALL	KFHZZ
43	13	XA-1316	•SEAL KIT	KFHZZ
43	14	AMA-3008	STATOR ASSEMBLY	XAHZZ
43	15	AMA-5AS	END HEAD	XAHZZ
43	16	XA-1317	•SEAL	KFHZZ
43	17	X-4071	•BEARING, OUTER	KFHZZ
43	18	AMA-50	•RETAINER, FELT	KFHZZ
43	19	X-4059	•WASHER, FELT	KFHZZ
43	20	AMA-49	•RETAINER, FELT	KFHZZ
43	21	X-4328	•RETAINER, BEARING	KFHZZ
43	22	XA-744AV	•O-RING	KFHZZ
43	23	AMA2004AS	•PARTS KIT, ENGINE GE	PAHZZ
43	24	XA-744AW	••RING SEAL BEARING	KFHZZ
43	25	12X-195	WASHER, LOCK	KFHZZ
43	26	20X-4383	SCREW, TAPPING	PAHZZ
43	27	12-333	PARTS KIT, GENERATOR	PAHZZ
43	28	AMA-0045	•INSULATOR, PLATE	PAHZZ
43	29	AMA-1046A	•RECTIFIER, HEAT	KFHZZ
43	30	VSF-16	•WASHER, FLAT	PAHZZ
43	31	MS51412-1	•WASHER, FLAT	PAHZZ
43	32	9419836	•SCREW, ASSEMBLED, WAS	PAHZZ
43	33	AMA-1042AS	•PARTS KIT, ENGINE GE	PAHZZ
43	34	MS35206-230	•SCREW, MACHINE	PAHZZ

FIG NO	ITEM NO	MFG P/N	ITEM NAME	MARINE CORPS PECULIAR SMRC
43	35	12X-196	•WASHER, LOCK	KFHZZ
43	36	MS35207-261	•SCREW, MACHINE	PAHZZ
43	37	MS35206-214	•SCREW, MACHINE	PAHZZ
43	38	AMA-1015AS	•PARTS KIT, ENGINE GE	PAHZZ
43	39	MS35206-231	••SCREW, MACHINE	PAHZZ
43	40	AMA-1015SS	HOLDER, ELECTRICAL C	KFHZZ
43	41	AMA-48	••INSULATOR, PLATE	PAHZZ
43	42	AMA-1026AS	••INSULATOR, PLATE	PAHZZ
43	43	AMA-19	•SPRING	KFHZZ
43	44	AMA-12	•BRUSH	KFHZZ
43	45	MS51863-22	•SCREW, TAPPING	PAHZZ
43	46	AMA1096	•CAPACITOR, FIXED, PLA	PAHZZ
43	47	2436161	•WASHER, FLAT	PAHZZ
43	48	MS35338-46	•WASHER, LOCK	PAHZZ
43	49	MS51968-2	•NUT, PLAIN, HEXAGON	PAHZZ
43	50	AMA-95	•STRAP, OUTPUT, GENERA	PAHZZ
43	51	AMA-2028BS	•PLATE, WIRING HARNES	XAHZZ
43	52	AMA-2028B5	••PACKING, PREFORMED	PAHZZ
43	53	AMA-2028BS	••PLATE, WIRING HARNES	PAHZZ
43	54	35-762	PARTS KIT, GENERATOR	PAHZZ
43	55	6-32 1-4	•SCREW, ASSEMBLED, WAS	PAHZZ
43	56	20X-4222	•PLUG, YOKE, ADJUSTING	KFHZZ
43	57	12X-196	•WASHER, LOCK	KFHZZ
43	58	20X-4063	•SCREW, TORX	KFHZZ
43	59	AMA-20	•BOLT, THRU, TORX	KFHZZ
43	60	20X-4061	•SCREW, FLAT HEAD	KFHZZ
44	2	MFY-6701UT	STARTER, ENGINE, ELEC	PAOHH
45	1	ML-129	WASHER, FLAT	KFHZZ
45	2	MFY-1130	PLATE ASSEMBLY, STAR	PAHZZ
45	3	XA-1642	•SEAL	PAHZZ
45	4	MS17795-128	•BEARING SLEEVE	PAHZZ
45	5	13X-5549	•SCREW, FILL HEAD	KFFZZ
45	6	MFY-25	GASKET, INTERMEDIATE	KFFZZ
45	7	MFY-133	SPACER	KFHZZ
45	8	DRA-3002D	DRIVE, ENGINE, ELECTR	PAHZZ
45	9	XA-744Z	O-RING	PAHZZ
45	10	MFY-53	PINION STOP STARTER	KFHZZ
45	11	MCCS-47A	SNAP RING STARTER	KFHZZ
45	12	MEU-2042B	SHIFTER FORK, NONVEH	PAHZZ
45	13	MES-117A	PIN, STRAIGHT	KFHZZ
45	14	20X-4222	PLUG, YOKE, ADJUSTING	KFHZZ
45	15	MFY-63	GASKET, PLUG	KFHZZ
45	16	MES-61	PLUG, YOKE, ADJUSTING	KFHZZ
45	17	PS-1475SS	HOUSING, PINION, STAR	PAHZZ
45	18	MEL50	•BEARING, SLEEVE	PAHZZ
45	19	8X-4678	SCREW, HEX HEAD	KFHZZ
45	20	SAT4108UT	SOLENOID, ELECTRICAL	PAHZZ
45	21	SAV-1008A	•CORE ASSEMBLY, SOLEN	PAHZZ
45	22	8X-1681	•NUT	KFHZZ
45	23	6X-4336	•SNAP RING CORE END	KFHZZ
45	24	SAT-48	•RETAINER CORE	KFHZZ
45	25	SAT-52	•SPRING, CORE	KFHZZ

FIG NO	ITEM NO	MFG P/N	ITEM NAME	MARINE CORPS PECULIAR SMRC
45	26	SAT-47	•RETAINER CORE	KFHZZ
45	27	IPD8S5128	•BOOT	KFHZZ
45	28	SAT-46	•WASHER, SOLENOID	KFHZZ
45	29	X-3331	•WASHER, LOCK	PAHZZ
45	30	MS35207-261	•SCREW, MACHINE	PAHZZ
45	31	SAT-1004F	•COVER AND CONTACT	KFHZZ
45	32	SAT-32	•GASKET	KFHZZ
45	33	X-3508	•NUT, HEXAGON, ELASTIC	KFHZZ
45	34	8X-349	•WASHER, PLAIN	KFHZZ
45	35	SAT-1014B	•CONTACT ASSEMBLY	KFHZZ
45	36	SS-88A	•SPRING	KFHZZ
45	37	SAT-40	•WASHER, STEEL	KFHZZ
45	38	MBD-2566	ARMATURE, MOTOR	XBHZZ
45	39	GK-174A	THRUST WASHER	KFHZZ
45	40	ML-128A	THRUST WASHER	KFHZZ
45	41	MES-95S	GASKET	PAHZZ
45	42	MFY-2101SS	FRAME AND FIELD ASY	XAHZZ
45	43	MS35207-263	•SCREW, MACHINE	PAHZZ
45	44	MZ-414S	•WASHER, FLAT	PAHZZ
45	45	MFY-1064B	•HOLDER, ELECTRICAL C	PAHZZ
45	46	MFJ-13A	•BRUSH, STARTER MOTOR	KFHZZ
45	47	MS35207-261	•SCREW, MACHINE	PAHZZ
45	48	MFY-19	•SPRING, BRUSH	KFHZZ
45	49	MS35650-302	•NUT, PLAIN, HEXAGON	PAHZZ
45	50	92-2923	WASHER, LOCK	PAHZZ
45	51	MS35206-242	•SCREW, MACHINE	PAHZZ
45	52	XA-744AP	•SEAL, O-RING, STARTER	KFHZZ
45	53	MAW-37	BUSHING, INSULATING	KFHZZ
45	54	MBD-444	WASHER, NEOPRENE	KFHZZ
45	55	MBD-438	WASHER, INSULATING	KFHZZ
45	56	MBD-442	WASHER, CAP, STARTER	KFHZZ
45	57	MZ-294	WASHER, PLAIN	KFHZZ
45	58	12X-201	WASHER, LOCK	KFHZZ
45	59	8X-179	NUT, HEXAGON	KFHZZ
45	60	5741120	BRACKET, STARTER MOT	PFHZZ
45	61	8X-830	NUT, HEXAGON	KFHZZ
45	62	X-3925SC	WASHER, INSULATING	KFHZZ
45	63	MBD-439	WASHER, PLAIN	KFHZZ
45	64	MBD-233B	STUD, TERMINAL	KFHZZ
45	65	19X-4632	SCREW, MACHINE	KFHZZ
45	66	MFY-21	STUD, TERMINAL	KFHZZ
45	67	MFY1102S	END PLATE	PAHZZ
45	68	MAD-110A	•FELT, OIL RETAINER	KFHZZ
45	69	MFY-117	•BEARING, ABS BRONZE	KFHZZ
45	70	MFJ-28A	STUD, TERMINAL	KFHZZ
45	71	MES-71A	WASHER, INSULATING	KFHZZ
45	72	MES-72	BUSHING, INSULATING	KFHZZ
45	73	MES-94	WASHER, NEOPRENE	KFHZZ
45	74	MES-93	WASHER, INSULATING	KFHZZ
45	75	MES-91	WASHER, CAP	KFHZZ
45	76	37X-4914	SCREW, HEX HEAD	KFHZZ
45	77	MES-78A	WASHER, PLAIN	KFHZZ

FIG NO	ITEM NO	MFG P/N	ITEM NAME	MARINE CORPS PECULIAR SMRC
45	78	19X-3437	NUT, HEXAGON	KFHZZ
45	79	MFY-109	BRACKET, SOLENOID	PFHZZ
45	80	12X-198	WASHER, LOCK	KFHZZ
45	81	8X-3439	NUT, HEXAGON	KFHZZ
69	23	6TLMFTYI	BATTERY, STORAGE	PAOZZ
168	1	ZZ-T-381/36-1250-16.5/C/G2A/LTTR	TIRE, PNEUMATIC, VEH	PCOZZ
184	7	B1821BH050C125N	SCREW, CAP, HEXAGON	PAOZZ
199	2	MS27183-12	•WASHER, FLAT	PAOZZ
199	1	MS51943-34	•NUT, SELF-LOCKING	PAOZZ
199	45	AN5H6A	•BOLT, MACHINE	PAOZZ
225	36	12338813	PIN, STRAIGHT, HEADED	PAOZZ
226	19	12338813	PIN, STRAIGHT, HEADED	PAOZZ
274	17	MS51943-35	NUT, SELF-LOCKING	PAOZZ
274	25	B1821BH038C275N	SCREW, CAP, HEXAGON	PAOZZ
280	1	12339480-1	DOOR, VEHICULAR	PAOHH
280	1	12339480-2	DOOR, VEHICULAR	PAOHH
280	1	12339469-1	DOOR, VEHICULAR	PFOHH
280	1	12339469-2	DOOR, VEHICULAR	PFOHH
281	1	12339473-1	DOOR, VEHICULAR	PAOHH
281	1	12339473-2	DOOR, VEHICULAR	PAOHH
281	1	12339477-1	DOOR, VEHICULAR	PAOHH
281	1	12339477-2	DOOR, VEHICULAR	PAOHH
316	7	5581348	DOOR, ASSEMBLY	PAOHH
320	19	5581349	DOOR, ASSEMBLY	PAOHH
324	10	99890451	DOOR, ASSEMBLY	PAOHH
324	10	SF5581351	DOOR, ASSEMBLY	PAOHH
324	24	5581348	DOOR, ASSEMBLY	PAOHH
324	24	5581349	DOOR, ASSEMBLY	PAOHH
373	6	XB78323-05001	STUD, TURN BUTTON	PAOZZ
373	7	M24243/1-A403	RIVET, BLIND	PAOZZ
375	7	44702-10	BUCKLE	PAOZZ
375	4	12342442	CURTAIN, VEHICULAR	PAOHZ
404	6	10947517-2	GENERATOR, ENGINE AC	PAOHZ
406	1	60253	SCREW, SELF-LOCKING	PAHZZ
406	2	71122	WASHER	PAHZZ
406	3	A041071121	FAN AND HUB ASSEMBL	PAHZZ
406	4	11646898	SEAL, SINGLE LIP	PAHZZ
406	5	MS9068-030	PACKING, PREFORMED	PAHZZ
406	6	Z1110-74821	SCREW, CAP, SOCKET HE	PAHZZ
406	7	71117	END BELL, ELECTRICAL	PFHZZ
406	8	71125	SPACER, SLEEVE	PAHZZ
406	9	11646803	PACKING, PREFORMED	KFHZZ
406	10	11646902	BEARING, BALL, ANNULA	PAHZZ
406	11	60249	KEY, MACHINE	PAHZZ
406	12	71127	ROTOR, GENERATOR	XAHZZ
406	13	11646896	SEAL, SINGLE LIP	PFHZZ
406	14	95962	CONNECTOR, ALTERNA	KAHZZ
406	15	75824	END BELL, ELECTRICAL	XAHZZ
406	16	71116	HOLDER AND STUD ASSY	PAHZZ
406	17	60198	PACKING, PREFORMED	PAHZZ
406	18	11646900	BRUSH, ELECTRICAL CO	PAHZZ

FIG NO	ITEM NO	MFG P/N	ITEM NAME	MARINE CORPS PECULIAR SMRC
406	19	4465	SCREW, MACHINE	PAHZZ
406	20	59234	PLATE, RETAINER, BEA	PAHZZ
406	21	11646899	SEAL, SINGLE LIP	KFHZZ
406	22	71126	SPACER, RING	PAHZZ
406	23	11646804	PACKING, PREFORMED	KFHZZ
406	24	11646897	BEARING, BALL, ANNULA	PAHZZ
406	25	A051074806	RECTIFIER, SEMICONDU	PAHZZ
406	26	11646901	RECTIFIER AND LEAD	PAHZZ
406	27	75884	BOLT, ASSEMBLED, WASH	PAHZZ
406	28	74808	RECTIFIER AND LEAD	PAHZZ
406	29	96470	SCREW, CAP, SOCKET HE	PAHZZ
406	30	36900	WASHER	PAHZZ
406	31	36896	WASHER, LOCK	PAHZZ
406	32	96471	INSULATOR, WASHER	PAHZZ
406	33	36196	COVER, TERMINAL	PAHZZ
406	34	MS35338-42	WASHER, LOCK	PAHZZ
406	35	2295	SCREW, MACHINE	PAHZZ

**i. BOI.** The Basis of Issue (BOI) for the tools listed in section III of this RPSTL is as follows:

Level	Unit Description	BOI
Unit (O)	Maintenance unit, section or team (authorized common tool set)	1
Direct Support (DS)	Company/System Support Team (except the following)	1
	Motorized Division/Heavy Division Heavy Maintenance Co.	2
	Airborne/Assault Division Forward Support Co.	2
	Heavy Maintenance Co.	3
	Light Infantry Division Heavy Maintenance Co.	6
	Light Maintenance Co.	0
General Support (GS)	Maintenance Co.	1
	Heavy Equipment Maintenance Co.	2

**j.** The NSNs for the Unit, Direct and General Support Special Tool Kits are listed on page B-20, in Section III of TM 9-2320-280-20-3.

**6. How to Locate Repair Parts.**

**a. When National Stock Number or Part Number is Not Known.**

**(1) First.** Using the table of contents, determine the assembly group or subassembly group to which the item belongs. This is necessary since figures are prepared for assembly groups and subassembly groups, and listings are divided into the same groups.

**(2) Second.** Find the figure covering the assembly group or subassembly group to which the item belongs.

**(3) Third.** Identify the item on the figure and use the Figure and Item Number Index to find the NSN.



**b. When National Stock Number or Part Number is Known.**

**(1) First.** Using the Index of National Stock Numbers and Part Numbers, find the pertinent National Stock Number or Part Number. The NSN index is in National Item Identification Number (NIIN) sequence (see 4.a.(1)). The part numbers in the Part Number index are listed in ascending alphanumeric sequence (see 4.b.). Both indexes cross-reference you to the illustration figure and item number of the item you are looking for.

**(2) Second.** After finding the figure and item number, verify that the item is the one you're looking for, then locate the item number in the repair parts list for the figure.

**7. How to Identify Engine Models.**

1990 and above engines have some new and revised parts which are not interchangeable with parts for previous model engines. Make sure you know which engine model you have before ordering replacement parts. The 1990 engine is identified by a decal which is adhered to the left rocker arm cover. The 6.5L engine is identified by serial number bar code decal.



**6.2 LITER**

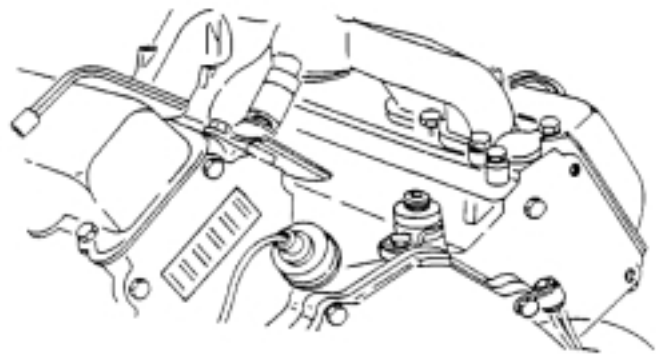

**6.5 LITER**

1 — 2  
thru  
6

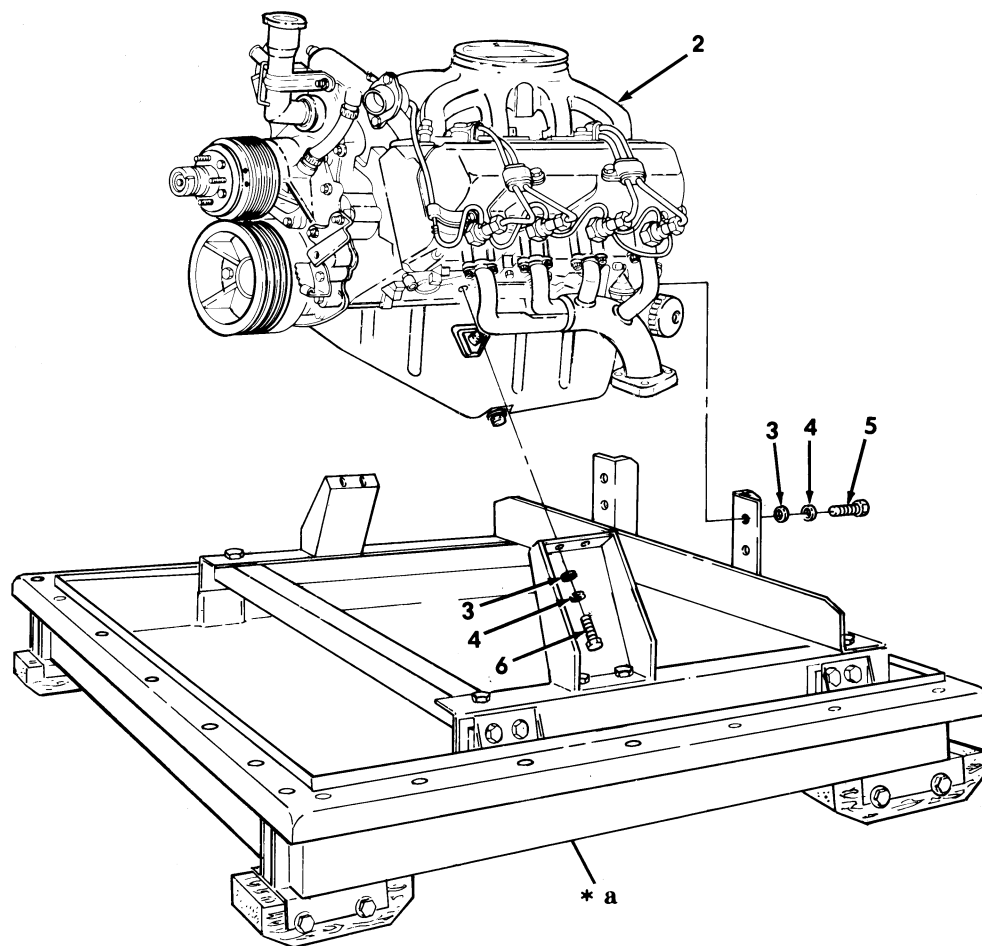
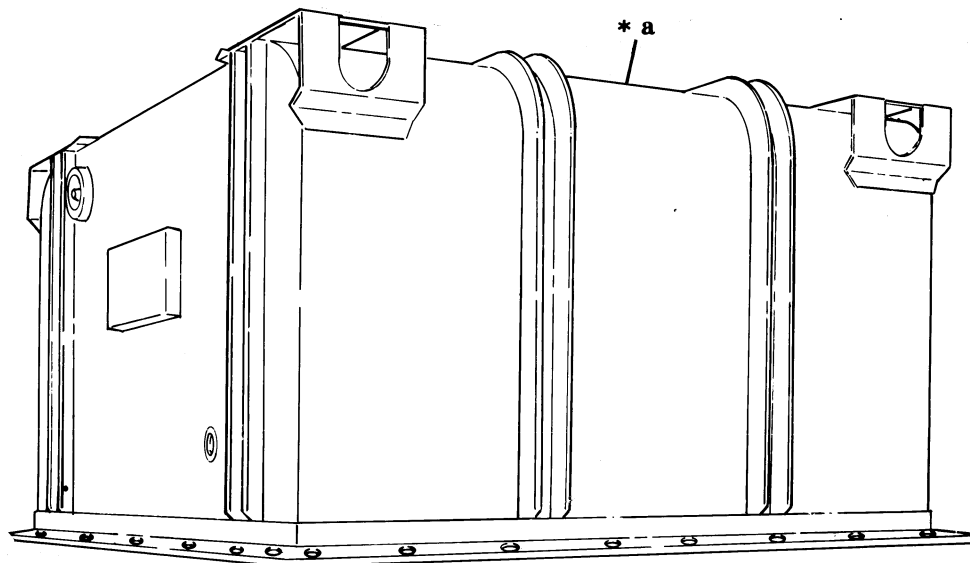

\* a PART OF ITEM 1

Figure 1. Engine and Container Assembly.

SECTION II			TM9-2320-280-24P			
(1)	(2)	(3)	(4)	(5)	(6)	(7)
ITEM NO	SMR CODE	NSN	CAGEC	PART NUMBER	DESCRIPTION AND USABLE ON CODES(UOC)	QTY
					GROUP 01 ENGINE 0100 ENGINE ASSEMBLY	
					FIG. 1 ENGINE AND CONTAINER ASSEMBLY	
1	PAFHH	2815012313672	19207	5705684	ENGINE AND CONTAIN 6.2 LITER,USBL EFF 1 THRU 99,999..... UOC:H11,H13,H14,H15,H16,H17,H18,H20, H21,H24,H25,H26,H27,H28,MMM	1
1	PAFHH	2815013147940	19207	5705628	ENGINE AND CONTAIN 6.2 LITER,USBL EFF 100,000 AND ABOVE..... UOC:AVY,A11,A13,A14,A15,A20,A24,A25, A26,A27,B16,B17,B18,HVY,H11,H13,H14, H15,H16,H17,H18,H20,H21,H24,H25,H26, H27,H28,MMM	1
1	PAFHH	2815014066675	19207	57K3226	ENGINE,WITH CONTAIN 1996 6.5 LITER DETUNED FOR USE AS 6.2 LITER REPLACEMENT..... UOC:AVY,A11,A13,A14,A15,A20,A24,A25, A26,A27,B16,B17,B18,HVY,H11,H13,H14, H15,H16,H17,H18,H20,H21,H24,H25,H26, H27,H28,MMM	1
1	PAFHH	2815014396664	19207	57K3525	ENGINE,WITH CONTAIN 1997 6.5 LITER DETUNED FOR USE AS 6.2 LITER REPLACEMENT..... UOC:AVY,A11,A13,A14,A15,A20,A24,A25, A26,A27,B16,B17,B18,HVY,H11,H13,H14, H15,H16,H17,H18,H20,H21,H24,H25,H26, H27,H28,MMM	1
1	PAFHH	2815014537404	19207	57K3537	ENGINE,WITH CONTAIN 1998 6.5 LITER DETUNED FOR USE AS 6.2 LITER REPLACEMENT..... UOC:AVY,A11,A13,A14,A15,A20,A24,A25, A26,A27,B16,B17,B18,HVY,H11,H13,H14, H15,H16,H17,H18,H20,H21,H24,H25,H26, H27,H28,MMM	1
1	PAFHH	2815014109710	19207	57K3223	ENGINE WITH CONTAIN 1995 AND 1996 6.5 LITER..... UOC:BVY,B15,B20,B24,B25,C17,NNN	1
1	PAFHH	2815014396665	19207	57K3524	ENGINE,WITH CONTAIN 1997 6.5 LITER. UOC:BVY,B15,B20,B24,B25,C17,NNN	1
1	PAFHH	2815014537403	19207	57K3536	ENGINE,WITH CONTAIN 1998 6.5 LITER. UOC:BVY,B15,B20,B24,B25,C17,NNN	1
2	XAFHH		19207	12338770	.ENGINE,DIESEL 6.2 LITER,USBL EFF 1 THRU 99,999..... UOC:H11,H13,H14,H15,H16,H17,H18,H20, H21,H24,H25,H26,H27,H28,MMM	1
2	XAFHH		19207	12338770-4	.ENGINE,DIESEL 6.2 LITER,USBL EFF 100,000 AND ABOVE..... UOC:AVY,A11,A13,A14,A15,A20,A24,A25, A26,A27,B16,B17,B18,HVY,H11,H13,H14, H15,H16,H17,H18,H20,H21,H24,H25,H26, H27,H28,MMM	1

SECTION II			TM9-2320-280-24P			
(1)	(2)	(3)	(4)	(5)	(6)	(7)
ITEM	SMR			PART		
NO	CODE	NSN	CAGEC	NUMBER	DESCRIPTION AND USABLE ON CODES(UC)	QTY
2	XAFHH		19207	12460163-1	.ENGINE,DIESEL 1996 6.5 LITER DETUNED FOR USE AS 6.2 LITER REPLACEMENT..... UOC:AVY,A11,A13,A14,A15,A20,A24,A25, A26,A27,B16,B17,B18,HVY,H11,H13,H14, H15,H16,H17,H18,H20,H21,H24,H25,H26, H27,H28,MMM	1
2	XAFHH		19207	12460163-3	.ENGINE,DIESEL 1997 6.5 LITER DETUNED FOR USE AS 6.2 LITER REPLACEMENT..... UOC:AVY,A11,A13,A14,A15,A20,A24,A25, A26,A27,B16,B17,B18,HVY,H11,H13,H14, H15,H16,H17,H18,H20,H21,H24,H25,H26, H27,H28,MMM	1
2	XAFHH		19207	12460163-5	.ENGINE,DIESEL..1998 6.5 LITER DETUNED FOR USE AS 6.2 LITER REPLACEMENT..... UOC:AVY,A11,A13,A14,A15,A20,A24,A25, A26,A27,B16,B17,B18,HVY,H11,H13,H14, H15,H16,H17,H18,H20,H21,H24,H25,H26, H27,H28,MMM	1
2	XAFHH		19207	12447108-1	.ENGINE,DIESEL 1995 AND 1996 6.5 LITER..... UOC:BVY,B15,B20,B24,B25,C17,NNN	1
2	XAFHH		19207	12460490	.ENGINE,DIESEL..1997 6.5 LITER..... UOC:BVY,B15,B20,B24,B25,C17,NNN	1
2	XAFHH		19207	12469048	.ENGINE,DIESEL..1998 6.5 LITER..... UOC:BVY,B15,B20,B24,B25,C17,NNN	1
3	PAFZZ	5310008094061	96906	MS27183-15	.WASHER,FLAT 7/16.....	8
4	PAFZZ	5310006379541	96906	MS35338-46	.WASHER,LOCK 3/8.....	8
5	PAFZZ	5305007813926	80204	B1821BH038C275N	.SCREW,CAP,HEXAGON H 3/8-16 X 2.750	4
6	PAFZZ	5305005432419	80204	B1821BH038C113N	.SCREW,CAP,HEXAGON H 3/8-16 X 1.125	4

END OF FIGURE

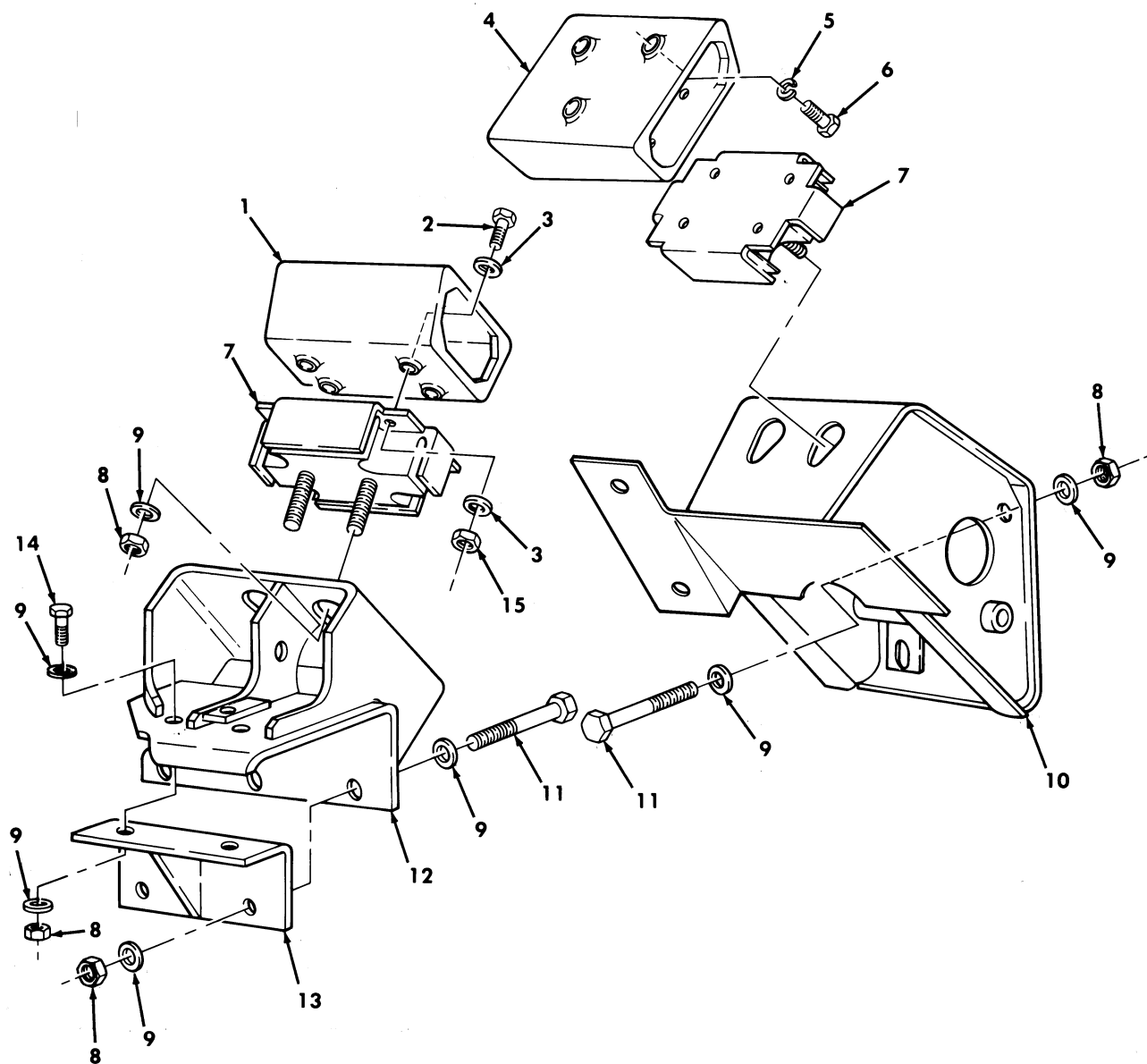
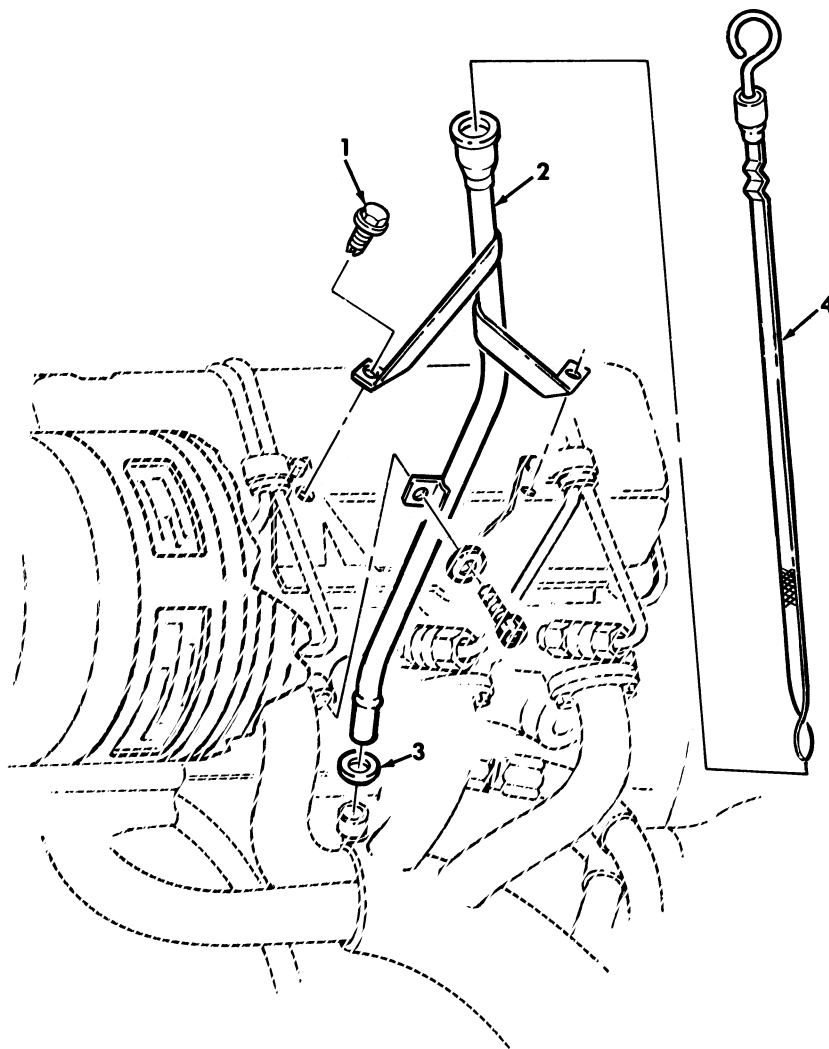

Figure 2. Engine Mounting Brackets.

SECTION II			TM9-2320-280-24P			
(1)	(2)	(3)	(4)	(5)	(6)	(7)
ITEM	SMR			PART		
NO	CODE	NSN	CAGEC	NUMBER	DESCRIPTION AND USABLE ON CODES(UOC)	QTY
GROUP 0100 ENGINE ASSEMBLY						
FIG. 2 ENGINE MOUNTING BRACKETS						
1	PAFZZ	2510011856115	19207	12339133	BRACKET,MOUNT,RESIL R.H.....	1
2	PAFZZ	5305005432419	80204	B1821BH038C113N	SCREW,CAP,HEXAGON H 3/8-16 X 1.25..	8
3	PAFZZ	5310000806004	96906	MS27183-14	WASHER,FLAT 3/8.....	16
4	PAFZZ	2510011856112	19207	12339132	BRACKET,ENGINE MOUN L.H.....	1
5	PAFZZ	5310006379541	96906	MS35338-46	WASHER,LOCK 3/8.....	6
6	PAFZZ	5305000680510	80204	B1821BH038C100N	SCREW,CAP,HEXAGON H 3/8-16 X 1.00..	6
7	PAFZZ	5342011899982	34623	5568310	MOUNT,RESILIENT.....	2
8	PAFZZ	5310004883889	96906	MS51943-39	NUT,SELF-LOCKING,HE 1/2-13.....	13
9	PAFZZ	5310011211703	06032	2310-0143-001	WASHER,FLAT 1/2.....	22
10	PAFZZ	2510011856113	19207	12338205	BRACKET,ENGINE MOUN.....	1
11	PAFZZ	5305000712081	80204	B1821BH050C450N	SCREW,CAP,HEXAGON H 1/2-13 X 4.50..	7
12	PAFZZ	2510011856114	19207	12338183	BRACKET,ENGINE MOUN R.H.....	1
13	PAFZZ	5340011867173	19207	12338163	BRACKET,ANGLE R.H.....	1
14	PAFZZ	5305009158087	80204	B1821BH050C125D	SCREW,CAP,HEXAGON H 1/2-13 X 1.25..	2
15	PAFZZ	5310009359021	96906	MS51943-35	NUT,SELF-LOCKING,HE 3/8-16.....	8

END OF FIGURE

2-3



**\* FOR DEEP WATER FORDING  
REFER TO GROUP 3305**

*Figure 3. Engine Oil Dipstick and Tube Assembly.*

SECTION II			TM9-2320-280-24P			
(1)	(2)	(3)	(4)	(5)	(6)	(7)
ITEM	SMR			PART		
NO	CODE	NSN	CAGEC	NUMBER	DESCRIPTION AND USABLE ON CODES(UC)	QTY
					GROUP 0106 ENGINE LUBRICATION SYSTEM	
					FIG. 3 ENGINE OIL DIPSTICK AND TUBE ASSEMBLY	
1	PAOZZ	5305012155174	19207	12340515	SCREW,ASSEMBLED WAS 4.2-1.41 X 13MM	2
2	PAOZZ	4710011961642	19207	12339170	TUBE ASSEMBLY,METAL.....	1
3	PAOZZ	5331009359136	11862	274244	.O-RING.....	1
4	PAOZZ	6680011794350	19207	12339168	GAGE ROD-CAP,LIQUID.....	1

END OF FIGURE



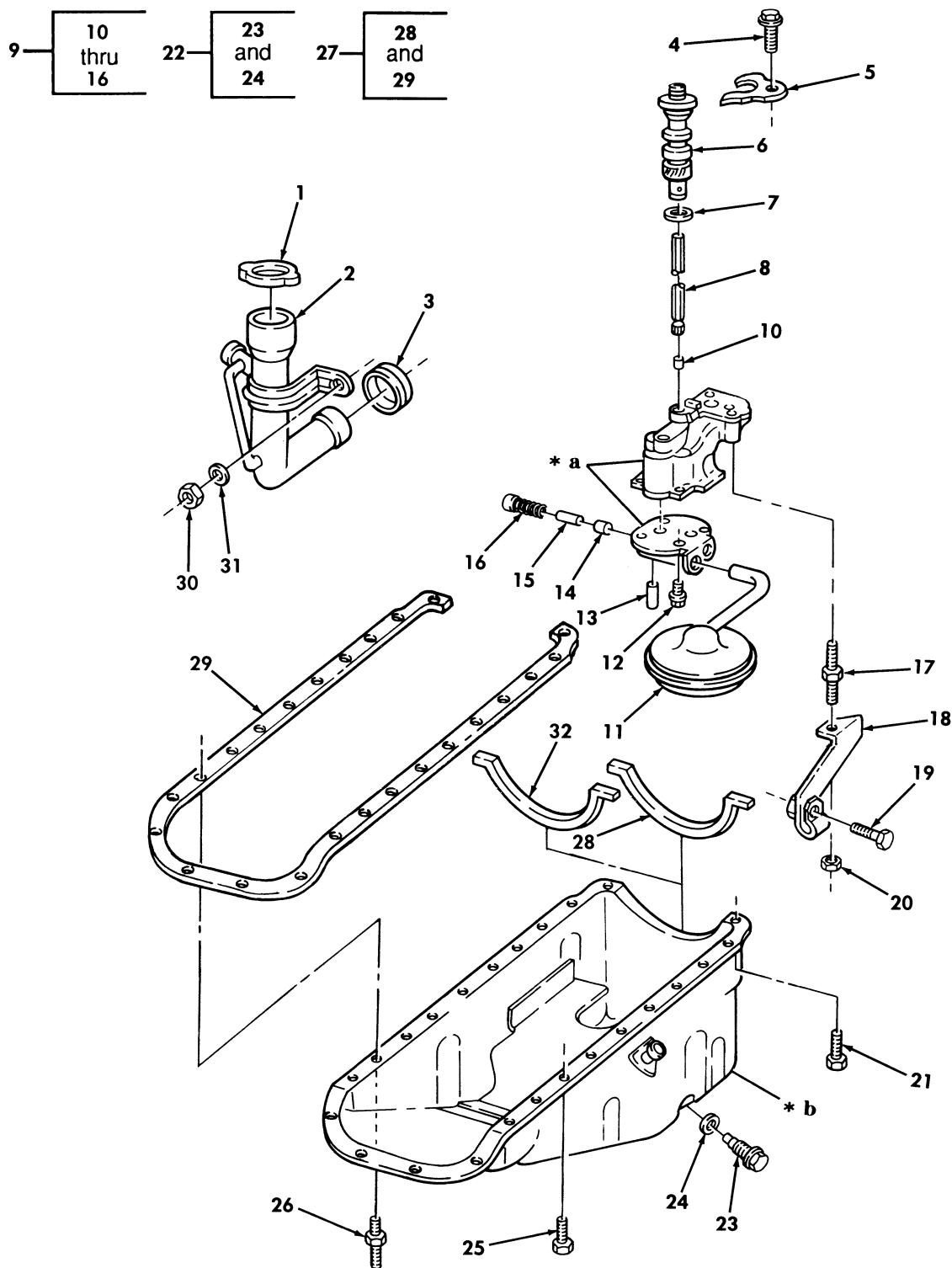

\* a PART OF ITEM 9  
 \* b PART OF ITEM 22

Figure 4. Engine Oil Pan, Pump, and Filler Tube.

SECTION II			TM9-2320-280-24P			
(1)	(2)	(3)	(4)	(5)	(6)	(7)
ITEM NO	SMR CODE	NSN	CAGEC	PART NUMBER	DESCRIPTION AND USABLE ON CODES(UC)	QTY
GROUP 0106 ENGINE LUBRICATION SYSTEM						
FIG. 4 ENGINE OIL PAN,PUMP,AND FILLER TUBE						
1	PAOZZ	2590011965228	78225	AX2022-02	CAP,FILLER OPENING.....	1
2	PAOZZ	2590011474285	7X677	14071059	FILLER NECK.....	1
3	PAOZZ	5325011516117	7X677	14028942	GROMMET,NONMETALLIC.....	1
4	PAFZZ	5306011496280	7X677	1635490	BOLT,SELF-LOCKING 10-1.5 X 25MM....	1
5	PAFZZ	5342011604397	7X677	14022650	CLAMP.....	1
6	PAFZZ	2815014495585	7X677	7849306	DRIVE SHAFT ASSEMBL.....	1
7	PAFZZ	5330011565147	7X677	14022649	GASKET.....	1
8	PAFZZ	3040011637208	7X677	14022699	SHAFT,STRAIGHT.....	1
9	PAFFF	2815011687871	72582	23502073	PUMP AND SCREEN,OIL ALL 6.2 LITER, 1995,96 6.5 LITER-N/A,AND 1996,97,98 6.5 DETUNED.....	1
9	PAFZZ	2815014750825	72582	12556342	OIL PUMP ASSEMBLY,E 1997,98 6.5 LITER.....	1
					UOC:BVY,B15,B20,B24,B25,C17,NNN	
10	PAFZZ	5330011547159	7X677	477249	.RETAINER,PACKING.....	1
11	PAFZZ	2910011898851	7X677	23500008	.STRAINER ELEMENT,SE 6.2 LITER AND 6.5 DETUNED,USE WITH P/N 23502073... UOC:AVY,A11,A13,A14,A15,A20,A24,A25, A26,A27,B16,B17,B18,HVY,H11,H13,H14, H15,H16,H17,H18,H20,H21,H24,H25,H26, H27,H28,MMM	1
11	PAFZZ	4730014733279	7X677	12556688	.STRAINER ELEMENT,SE 6.5 LITER,USE WITH P/N 12556342.....	1
					UOC:BVY,B15,B20,B24,B25,C17,NNN	
12	PAFZZ	5306011655582	7X677	11508600	.BOLT,MACHINE 6-1.0 X 20 MM USE WITH P/N 23502073.....	4
13	PAFZZ	5315008285487	73957	3-32X3-4LG	.PIN,GROOVED,HEADLES USE WITH P/N 23502073.....	1
14	PAFZZ	5340011945294	7X677	3704871	.DISK,SOLID,PLAIN USE WITH P/N 23502073.....	1
15	PAFZZ	2805003361716	7X677	3702366	.VALVE,RELIEF,PRESSU USE WITH P/N 23502073.....	1
16	PAFZZ	5360011651563	7X677	360582	.SPRING,HELICAL,COMP USE WITH P/N 23502073.....	1
17	PAFZZ	5307011870519	7X677	23500006	STUD,SHOULDERED AND.....	1
18	PAFZZ	5340013849987	34623	5741613	BRACKET,ANGLE 6.2 LITER AND 6.5 DETUNED.....	1
					UOC:AVY,A11,A13,A14,A15,A20,A24,A25, A26,A27,B16,B17,B18,HVY,H11,H13,H14, H15,H16,H17,H18,H20,H21,H24,H25,H26, H27,H28,MMM	
18	PAFZZ	5340014728851	7X677	12557708	BRACKET,ANGLE 6.5 LITER.....	1
					UOC:BVY,B15,B20,B24,B25,C17,NNN	
19	PAFZZ	5306012537073	7X677	11508353	BOLT,MACHINE.....	1
20	PAFZZ	5310012507679	72582	23521131	NUT 11-1.5 MM.....	1
21	PAOZZ	5306012303354	7X677	11508534	BOLT,MACHINE 8-1.25 X 16 MM.....	2
22	PAOFF	2815011687912	34623	5588022	OIL PAN 6.2 LITER.....	1
					UOC:AVY,A11,A13,A14,A15,A20,A24,A25,	

SECTION II			TM9-2320-280-24P			
(1)	(2)	(3)	(4)	(5)	(6)	(7)
ITEM NO	SMR CODE	NSN	CAGEC	PART NUMBER	DESCRIPTION AND USABLE ON CODES(UOC)	QTY
					A26,A27,B16,B17,B18,HVY,H11,H13,H14,H15,H16,H17,H18,H20,H21,H24,H25,H26,H27,H28,MMM	
22	PAOFF	2815014302599	7X677	12551755	OIL PAN 6.5 LITER AND 6.5 DETUNED..	1
					UOC:BVY,B15,B20,B24,B25,C17,NNN	
23	PAOZZ	5365011880782	72582	23011420	.PLUG,MACHINE THREAD.....	1
24	PAOZZ	5330008556045	96906	MS35769-9	.GASKET.....	1
25	PAOZZ	5305011509781	7X677	8639743	SCREW,CAP,HEXAGON H 6-1.0 X 16MM...	20
26	PAOZZ	5307011964717	34623	5591286	STUD,SPECIAL 6-1.0 X 37.4MM.....	2
27	PAOZZ	5330013106780	73165	OS34400	GASKET SET 6.2 LITER.....	1
					UOC:AVY,A11,A13,A14,A15,A20,A24,A25,A26,A27,B16,B17,B18,HVY,H11,H13,H14,H15,H16,H17,H18,H20,H21,H24,H25,H26,H27,H28,MMM	
28	PAOZZ	5330011507744	7X677	14022683	.SEAL,NONMETALLIC SP 6.2 LITER.....	1
					UOC:AVY,A11,A13,A14,A15,A20,A24,A25,A26,A27,B16,B17,B18,HVY,H11,H13,H14,H15,H16,H17,H18,H20,H21,H24,H25,H26,H27,H28,MMM	
29	PAOZZ	5330014255069	73165	91598	.GASKET 6.2 LITER.....	1
					UOC:AVY,A11,A13,A14,A15,A20,A24,A25,A26,A27,B16,B17,B18,HVY,H11,H13,H14,H15,H16,H17,H18,H20,H21,H24,H25,H26,H27,H28,MMM	
30	PAOZZ	5310011653331	7X677	22521550	NUT,PLAIN,HEXAGON 8-1.25 MM.....	2
31	PAOZZ	5310008093078	96906	MS27183-11	WASHER,FLAT 1/4.....	2
32	PAOZZ	5330013788572	7X677	23502587	RETAINER,OIL SEAL 6.5 AND 6.5	1
					DETUNED.....	

END OF FIGURE

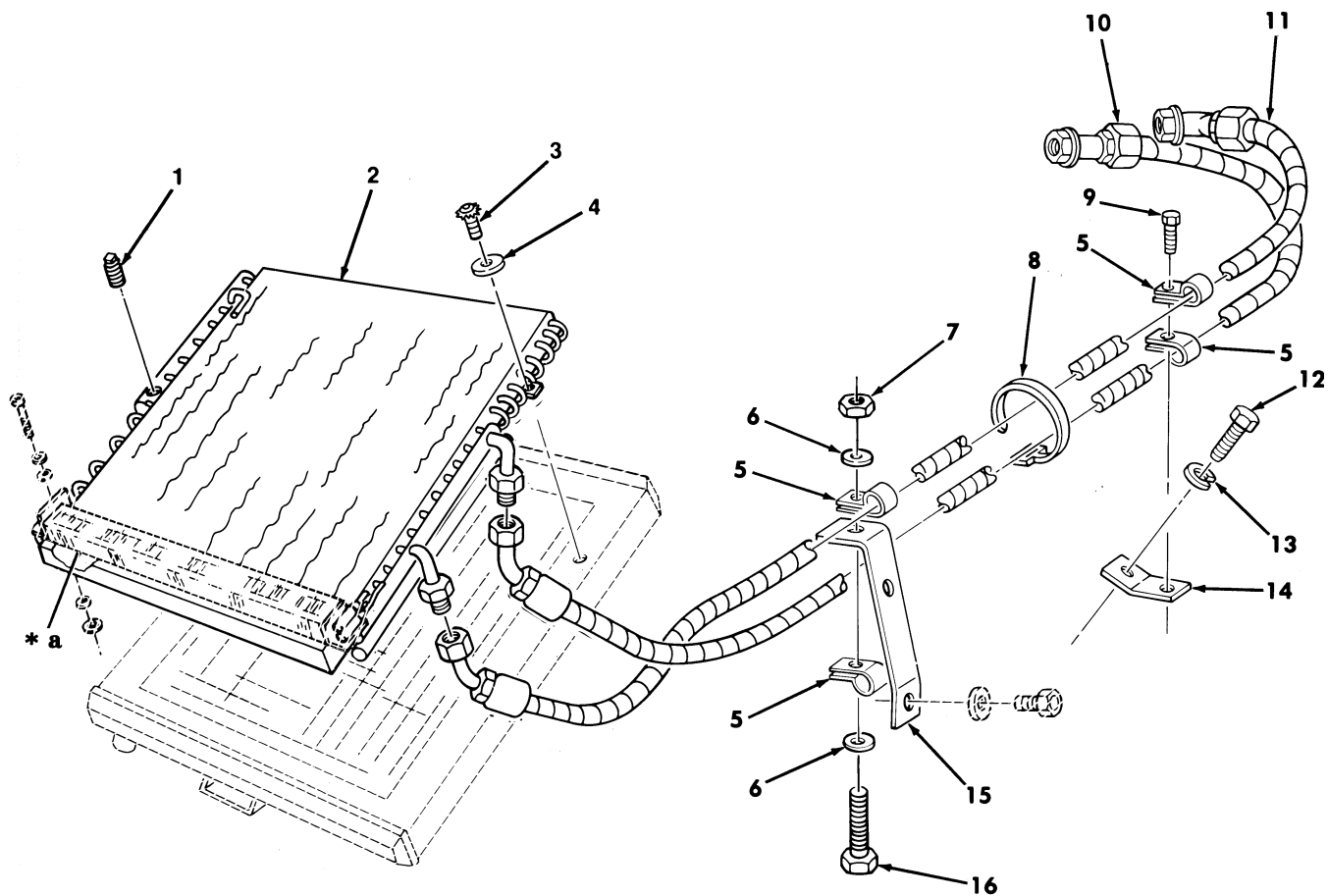

**\* a POWER STEERING OIL COOLER  
SEE FIGURE 178**

*Figure 5. Engine and Transmission Oil Cooler and Engine Oil Cooler Lines.*

SECTION II			TM9-2320-280-24P			
(1)	(2)	(3)	(4)	(5)	(6)	(7)
ITEM	SMR			PART		
NO	CODE	NSN	CAGEC	NUMBER	DESCRIPTION AND USABLE ON CODES(UC)	QTY
GROUP 0106 ENGINE LUBRICATION SYSTEM						
FIG. 5 ENGINE AND TRANSMISSION OIL COOLER AND ENGINE OIL COOLER LINES						
1	PAOZZ	4730009541281	81348	WW-P-471ACACBCB	PLUG,PIPE.....	1
2	PAOFA	2930011687911	50022	19111	COOLER,LUBRICATING.....	1
3	PAOZZ	5305002257211	80205	MS16995-63	SCREW,CAP,SOCKET HE 5/16-18 X 5/16.	4
4	PAOZZ	5310000814219	96906	MS27183-12	WASHER,FLAT 5/16.....	4
5	PAOZZ	5340012293632	75272	COV-1609	CLAMP,LOOP.....	4
6	PAOZZ	5310008238804	96906	MS27183-9	WASHER,FLAT 1/4.....	2
7	PAOZZ	5310000614650	96906	MS51943-31	NUT,SELF-LOCKING,HE 1/4-20.....	1
8	PAFZZ	5975004515001	96906	MS3367-3-9	STRAP,TIEDOWN,ELECT.....	1
9	PAOZZ	5305010874478	96906	MS51851-95	SCREW,TAPPING 1/4-20 X 5/8.....	1
10	PAOZZ	4720011876911	34623	12339411-2	HOSE ASSEMBLY,NONME 55 INCHES.....	1
11	PAOZZ	4720012573705	01276	FB9665-02	HOSE ASSEMBLY,NONME 52 INCHES.....	1
12	PAOZZ	5305000518605	80205	MS16995-77	SCREW,CAP,SOCKET HE 3/8-16 X 3/4...	1
13	PAOZZ	5310006379541	96906	MS35338-46	WASHER,LOCK 3/8.....	1
14	PFOZZ	5340012124714	19207	12338777	BRACKET,ANGLE.....	1
15	PFOZZ	5340012102747	19207	12338779	BRACKET,OIL COOLER,.....	1
16	PAOZZ	5305002253842	80204	B1821BH025C113N	SCREW,CAP,HEXAGON H 1/4-20 X 1.125.	1

END OF FIGURE

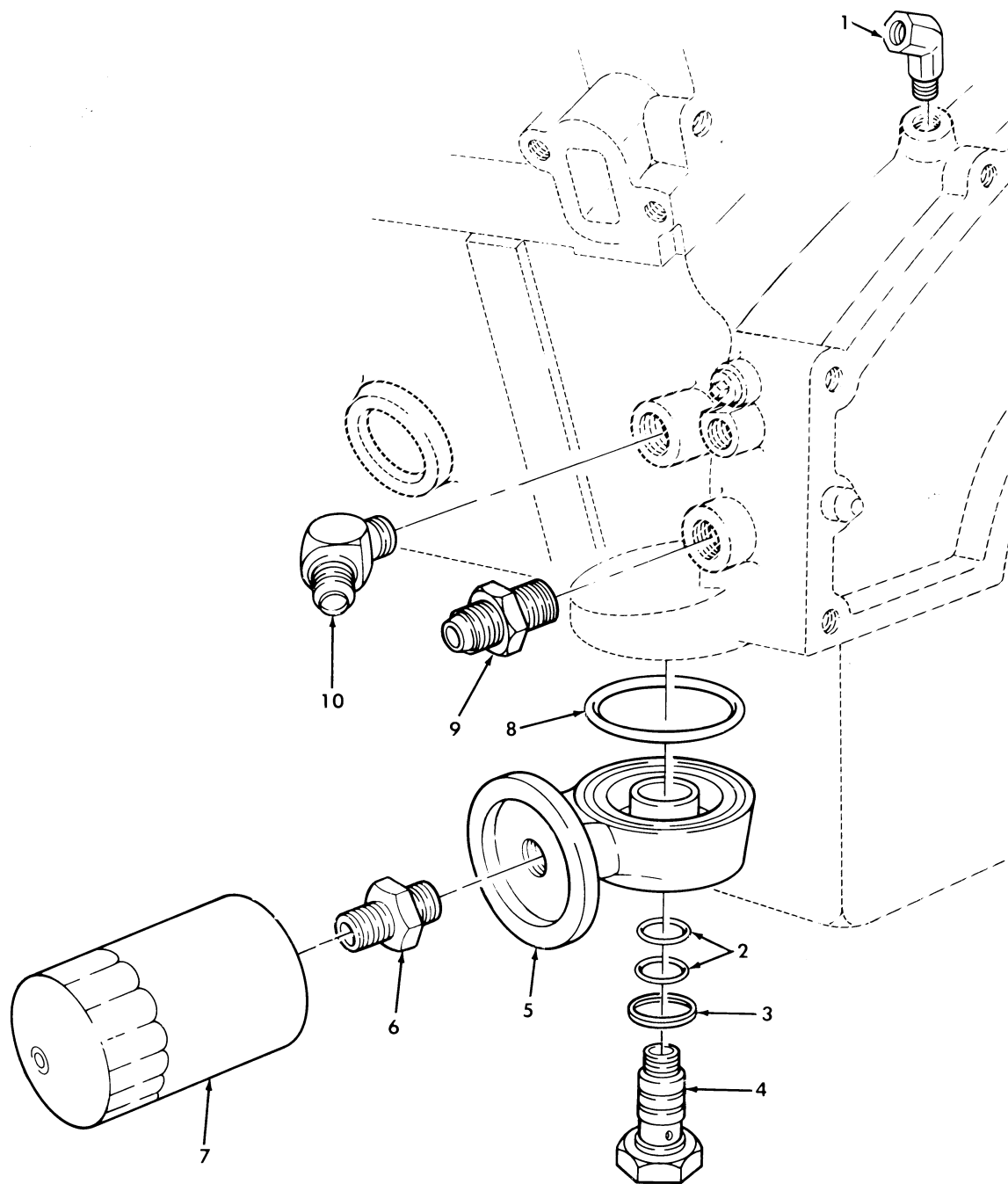

Figure 6. Oil Filter, Adapter, and Oil Line Fittings.

SECTION II			TM9-2320-280-24P			
(1)	(2)	(3)	(4)	(5)	(6)	(7)
ITEM NO	SMR CODE	NSN	CAGEC	PART NUMBER	DESCRIPTION AND USABLE ON CODES(UC)	QTY
GROUP 0106 ENGINE LUBRICATION SYSTEM						
FIG. 6 OIL FILTER, ADAPTER, AND OIL LINE FITTINGS						
1	PAOZZ	4730009115707	21450	454097	ELBOW, PIPE.....	1
2	PAOZZ	5331011074950	81349	M83461/1-020	O-RING.....	2
3	PAOZZ	5330011846500	34623	5577933	GASKET.....	1
4	PAOZZ	4730011876929	19207	12339410	BOLT, FLUID PASSAGE.....	1
5	PFOZZ	4730011687872	19207	12338780	BRACKET, FILTER MOUN.....	1
6	PAOZZ	4730011500879	7X677	14022700	REDUCER, BOSS.....	1
7	PAOZZ	2940000826034	73370	PH13	FILTER, FLUID 6.2 LITER.....	1
UOC:AVY,A11,A13,A14,A15,A20,A24,A25,A26,A27,B16,B17,B18,HVY,H11,H13,H14,H15,H16,H17,H18,H20,H21,H24,H25,H26,H27,H28,MMM						
7	PAOZZ	4330013988484	70040	PF1218	FILTER ELEMENT, FLUI 6.5 LITER AND 6.5 DETUNED.....	1
8	PAOZZ	5331011830971	81349	M83461/1-236	O-RING.....	1
9	PAOZZ	4730010661278	96906	MS51500A10-6	ADAPTER, STRAIGHT, PI 3/8-5/8.....	1
10	PAOZZ	4730007282393	01276	2023-6-10S	ELBOW, PIPE TO TUBE 3/8-5/8.....	1

END OF FIGURE

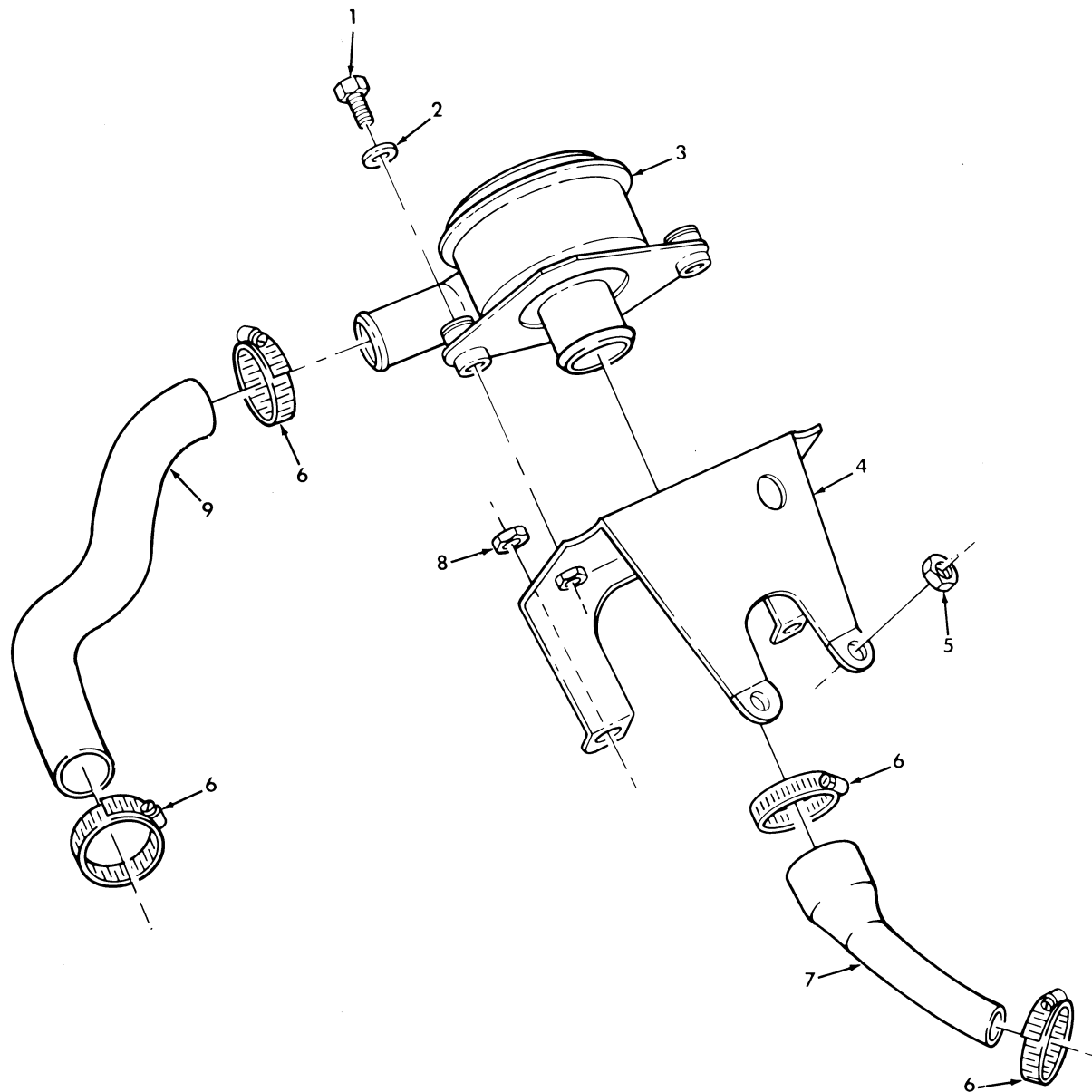

Figure 7. Crankcase Depression Regulator Valve and Mounting Hardware.



SECTION II			TM9-2320-280-24P			
(1)	(2)	(3)	(4)	(5)	(6)	(7)
ITEM	SMR			PART		
NO	CODE	NSN	CAGEC	NUMBER	DESCRIPTION AND USABLE ON CODES(UC)	QTY
GROUP 0106 ENGINE LUBRICATION SYSTEM						
FIG. 7 CRANKCASE DEPRESSION						
REGULATOR VALVE AND MOUNTING						
HARDWARE						
1	PAOZZ	5306011586224	24617	9419032	BOLT,MACHINE 5/16-18 X 1.25.....	2
2	PAOZZ	5310011193675	24617	9418304	WASHER,FLAT 5/16.....	2
3	PAOZZ	2990011479284	7X677	25042462	VALVE,POSITIVE CRAN.....	1
4	PFOZZ	5342012112897	19207	12339137	BRACKET ASSY.....	1
5	PAOZZ	5310011552503	7X677	11514603	NUT,PLAIN,HEXAGON 10-1.5 MM.....	2
6	PAOZZ	4730010887798	76599	4816SS-305	CLAMP,HOSE.....	4
7	PAOZZ	4720011873387	16563	LD-1501	HOSE,PREFORMED.....	1
8	PAOZZ	5310011653331	24617	11500749	NUT,PLAIN,HEXAGON 8-1.25 MM.....	2
9	PAOZZ	4720012100484	34623	5588701	HOSE,PREFORMED.....	1

END OF FIGURE

Section II.

TM 9-2320-280-24P-1

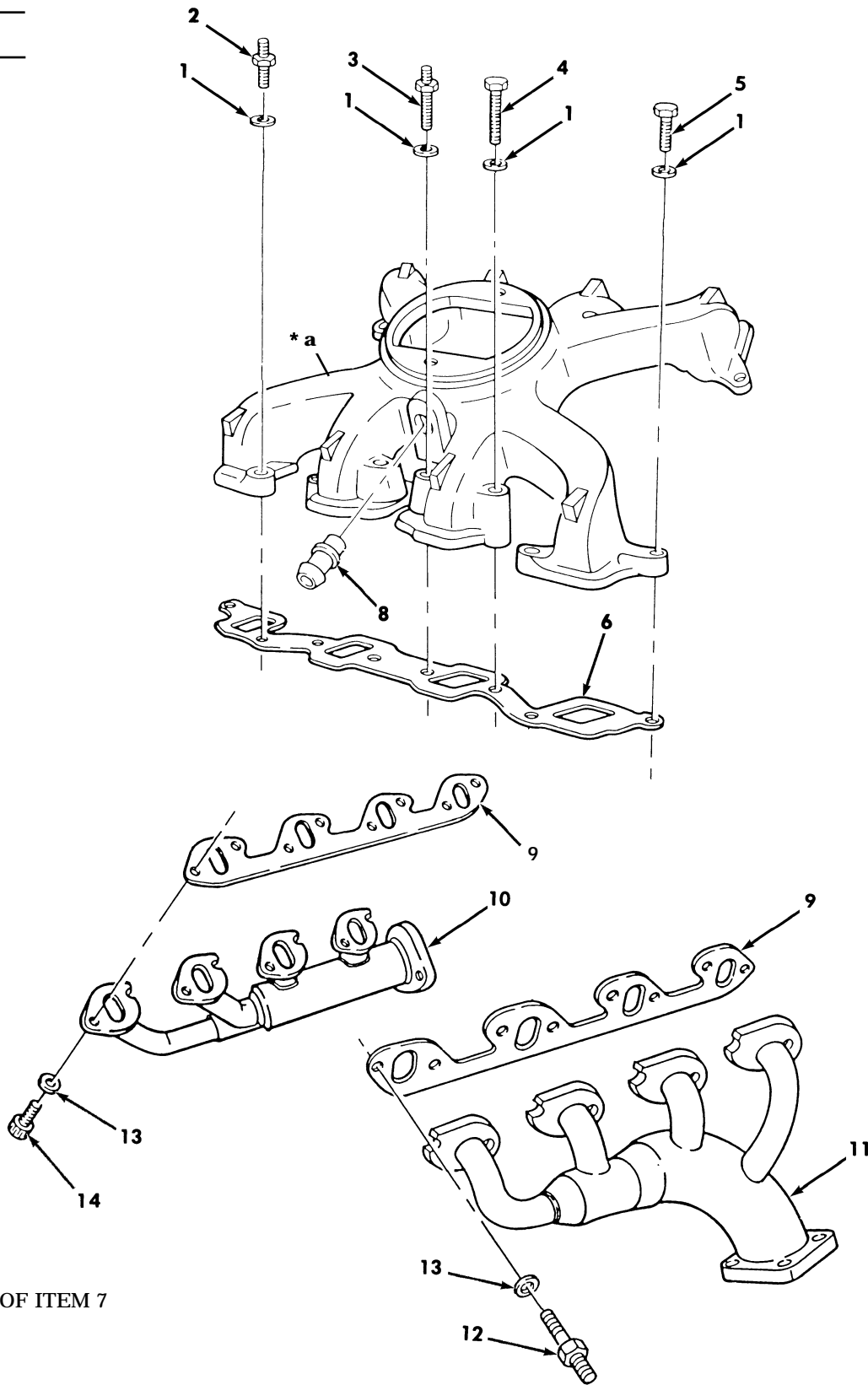
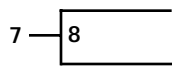
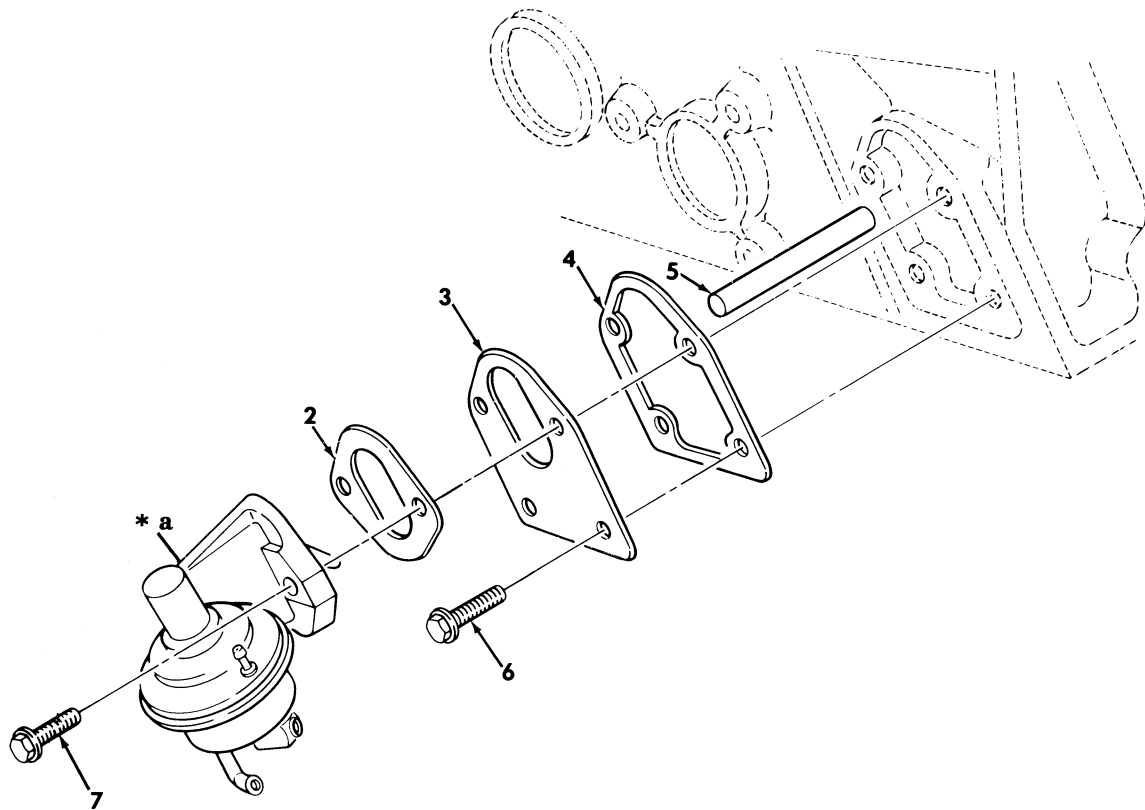

Figure 8. Air Intake and Exhaust Manifolds.

SECTION II			TM9-2320-280-24P			
(1)	(2)	(3)	(4)	(5)	(6)	(7)
ITEM NO	SMR CODE	NSN	CAGEC	PART NUMBER	DESCRIPTION AND USABLE ON CODES(UOC)	QTY
GROUP 0108 MANIFOLDS						
FIG. 8 AIR INTAKE AND EXHAUST MANIFOLDS						
1	PAFZZ	5310008094061	96906	MS27183-15	WASHER,FLAT 7/16.....	16
2	PAFZZ	5307011501227	7X677	14033946	STUD,SHOULDERED 10-1.5 X 20 X 30 MM	6
3	PAFZZ	5307011505991	7X677	23500832	STUD,SHOULDERED 10-1.5 X 17 X 56 MM	5
					UOC:BVY,B15,B20,B24,B25,C17,NNN	
3	PAFZZ	5307011505991	7X677	23500832	STUD,SHOULDERED 10-1.5 X 17 X 56 MM	4
					UOC:AVY,A11,A13,A14,A15,A20,A24,A25,A26,A27,B16,B17,B18,HVY,H11,H13,H14,H15,H16,H17,H18,H20,H21,H24,H25,H26,H27,H28,MMM	
4	PAFZZ	5305011485915	7X677	11505068	SCREW,CAP,HEXAGON H 10-1.5 X 60....	1
					UOC:AVY,A11,A13,A14,A15,A20,A24,A25,A26,A27,B16,B17,B18,HVY,H11,H13,H14,H15,H16,H17,H18,H20,H21,H24,H25,H26,H27,H28,MMM	
5	PAFZZ	5306011496280	7X677	1635490	BOLT,SELF-LOCKING 10-1.5 X 30 MM...	5
6	PAFZZ	5330011570856	7X677	15633464	GASKET SET.....	2
7	PAFZZ	2815011687909	7X677	23500035	MANIFOLD,INTAKE.....	1
8	PAOZZ	4730011647028	7X677	14050444	.ADAPTER,STRAIGHT,TU.....	1
9	PAOZZ	5330011940472	34623	5574856	GASKET.....	2
10	PAOZZ	2815011687917	19207	12338788	MANIFOLD,EXHAUST R.H.....	1
11	PAOZZ	2815011687918	19207	12338787	MANIFOLD,EXHAUST.....	1
12	PAOZZ	5307013153597	19207	12339406-3	STUD,SHOULDERED L.H.M10 X 1.5 X 30.0	1
13	PAOZZ	5310012101587	7X677	11500256	WASHER,FLAT 11MM.....	16
14	PAOZZ	5305011955818	19207	12339239-1	SCREW,CAP,SOCKET HE.....	15

END OF FIGURE

1-2



\* a PART OF ITEM 1

Figure 9. Fuel Pump and Mounting Hardware.

SECTION II			TM9-2320-280-24P			
(1)	(2)	(3)	(4)	(5)	(6)	(7)
ITEM	SMR			PART		
NO	CODE	NSN	CAGEC	NUMBER	DESCRIPTION AND USABLE ON CODES(UC)	QTY
					GROUP 03 FUEL SYSTEM	
					0302 FUEL PUMP	
					FIG. 9 FUEL PUMP AND MOUNTING	
					HARDWARE	
1	PAOZZ	2910011687905	19207	12342893	PUMP,FUEL,CAM ACTUA.....	1
2	PAOZZ	5330007006868	70040	1538769	.GASKET.....	1
3	PAOZZ	2910004932138	7X677	3719599	PLATE,FUEL PUMP.....	1
4	PAOZZ	5330014728179	7X677	12560223	GASKET.....	1
5	PAOZZ	5315011514180	7X677	14050425	PIN,STRAIGHT,HEADLE.....	1
6	PAOZZ	5306011514925	7X677	11509669	BOLT,ASSEMBLED WASH 6-1.0 X 13 MM..	2
7	PAOZZ	5306011487454	7X677	3895411	BOLT,ASSEMBLED WASH 3/8-16 X 1.44..	2

END OF FIGURE

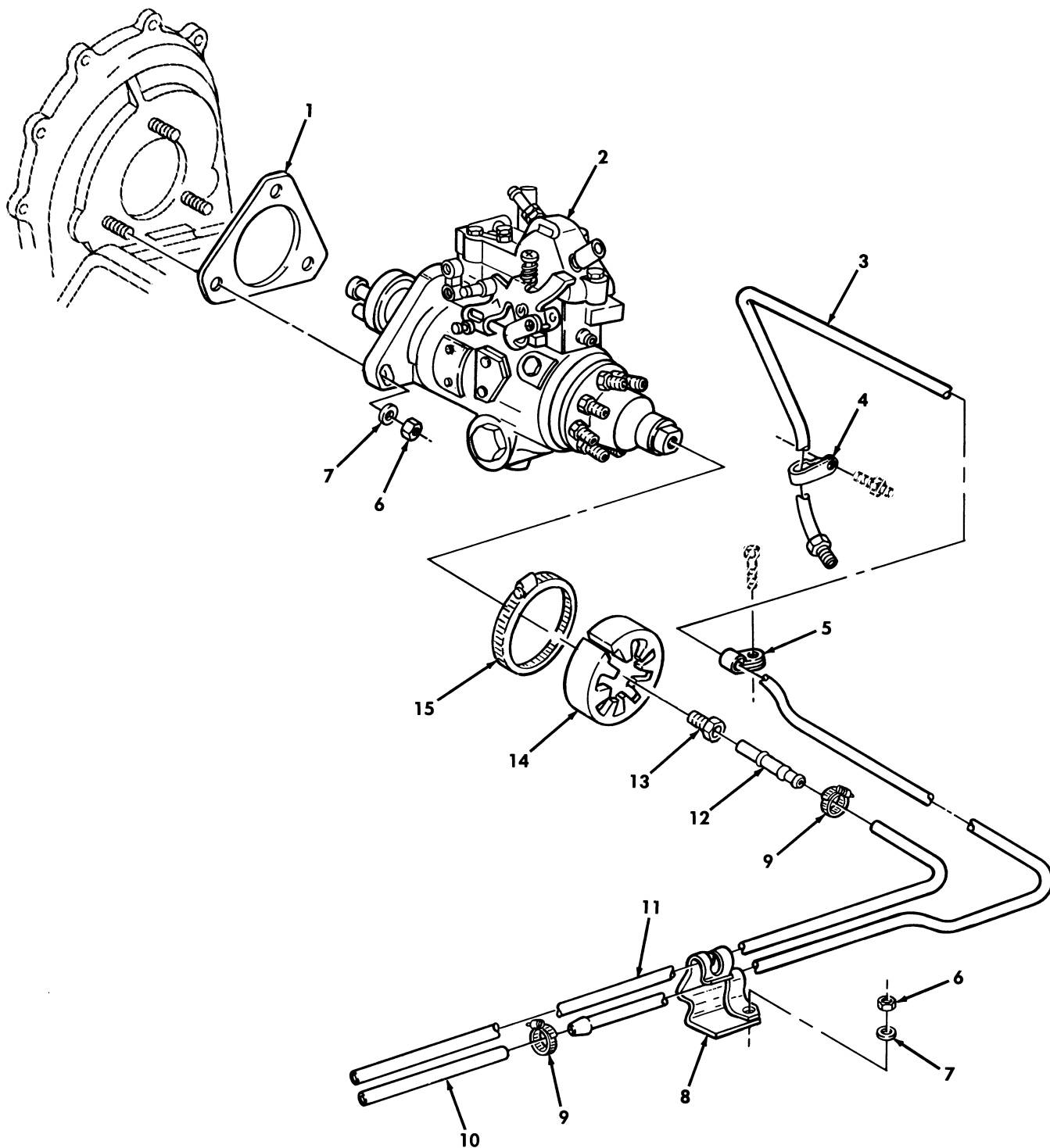

Figure 10. Fuel Injection Pump and Fuel Filter Lines.

SECTION II			TM9-2320-280-24P			
(1)	(2)	(3)	(4)	(5)	(6)	(7)
ITEM NO	SMR CODE	NSN	CAGEC	PART NUMBER	DESCRIPTION AND USABLE ON CODES(UOC)	QTY
GROUP 0302 FUEL INJECTION PUMP AND FUEL FILTER LINES						
FIG. 10 FUEL INJECTION PUMP AND FUEL FILTER LINES						
1	PAFZZ	5330011505944	7X677	10137486	GASKET.....	1
2	PAFHH	2910011992355	84760	DB2829-4523	PUMP,FUEL,METERING 6.2 LITER,USE PRIOR TO 1990 ENGINE UOC:H11,H13,H14,H15,H16,H17,H18,H20,H21,H24,H25,H26,H27,H28,MMM	1
2	PAFHH	2910014141272	84760	DB2831-5149	PUMP,FUEL,METERING 6.5 LITER.....	1
2	PAFHH	2910013269221	84760	DB2829-4879	PUMP,FUEL,METERING 6.2 LITER,USE WITH 1990 ENGINE AND ABOVE..... UOC:AVY,A11,A13,A14,A15,A20,A24,A25,A26,A27,B16,B17,B18,HVY,H11,H13,H14,H15,H16,H17,H18,H20,H21,H24,H25,H26,H27,H28,MMM	1
2	PAFHH	2910014679029	84760	DB2831-5209	PUMP,FUEL,METERING 6.5 LITER DETUNED..... UOC:AVY,A11,A13,A14,A15,A20,A24,A25,A26,A27,B16,B17,B18,HVY,H11,H13,H14,H15,H16,H17,H18,H20,H21,H24,H25,H26,H27,H28,MMM	1
3	PAFZZ	4710011856179	34623	5741611	TUBE ASSEMBLY,METAL.....	1
4	PAFZZ	5340011488349	7X677	14033896	CLIP,SPRING TENSION.....	1
5	PAOZZ	5340011487528	7X677	22511422	CLAMP,LOOP.....	1
6	PAOFF	5310011552503	7X677	11503639	NUT,PLAIN,HEXAGON 8-1.25 MM.....	4
7	PAOZZ	5310008093078	96906	MS27183-11	WASHER,FLAT 1/4.....	4
8	PAOZZ	5340011677794	7X677	14063340	CLAMP,LOOP.....	1
9	PAOZZ	4730008716729	7X677	2551880	CLAMP,HOSE.....	2
10	MOOZZ		34623	5740702	HOSE,NONMETALLIC MAKE FROM HOSE,P/N,9438373,10 INCHES LONG.....	1
11	MOOZZ		72825	23500024	HOSE,NONMETALLIC MAKE FROM HOSE,P/N,9438257,22 INCHES LONG.....	1
12	MFFZZ		11862	14063339	TUBE ASSEMBLY,METAL MAKE FROM TUBE,P/N 15618240,2.76 INCHES LONG.....	1
13	PAFZZ	4730000142432	24617	137397	INVERTED NUT,TUBE C.....	1
14	PAOZZ	5342012501098	19207	12339491-1	BOOT.....	1
15	PAOZZ	4730009086292	96906	MS35842-14	CLAMP,HOSE.....	1

END OF FIGURE

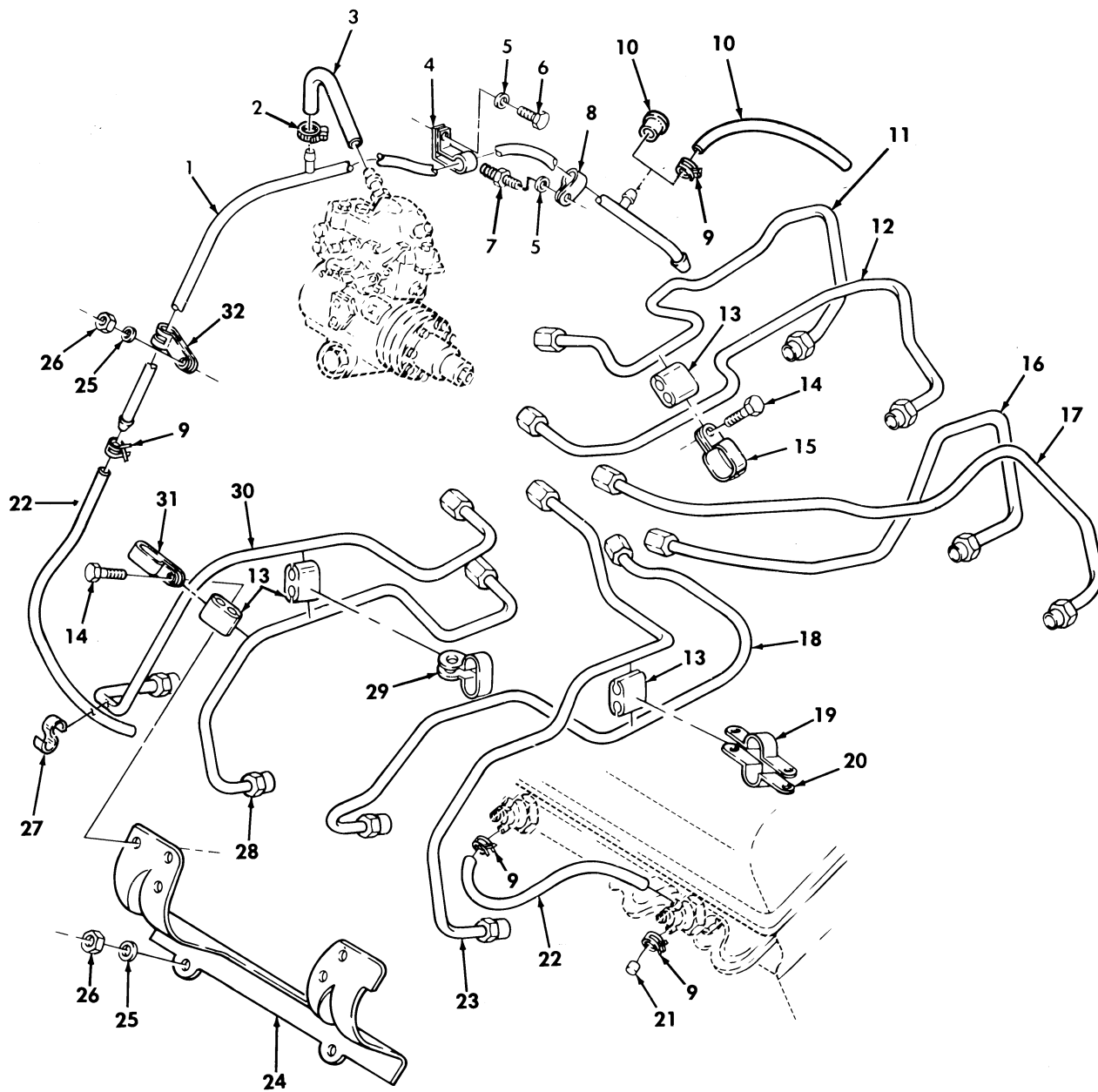

Figure 11. Fuel Injection Supply and Return Lines.



SECTION II			TM9-2320-280-24P			
(1)	(2)	(3)	(4)	(5)	(6)	(7)
ITEM NO	SMR CODE	NSN	CAGEC	PART NUMBER	DESCRIPTION AND USABLE ON CODES(UOC)	QTY
GROUP 0302 FUEL INJECTION PUMP AND FUEL FILTER LINES						
FIG. 11 FUEL INJECTION SUPPLY AND RETURN LINES						
1	PAOZZ	4710014469570	7X677	12554835	TUBE,BENT,METALLIC 6.5 LITER USE WITH PUMP ASSEMBLY P/N DB2831-5149 AND DB2831-5209.....	1
1	PFOZZ	4710011482659	7X677	14061569	TUBE,BENT,METALLIC 6.2 LITER..... UOC:AVY,A11,A13,A14,A15,A20,A24,A25,A26,A27,B16,B17,B18,HVY,H11,H13,H14,H15,H16,H17,H18,H20,H21,H24,H25,H26,H27,H28,MMM	1
2	PAOZZ	4730011188278	76599	MMF4-SS	CLAMP,HOSE.....	2
3	MOOZZ		11862	9439363	HOSE,NONMETALLIC MAKE FROM HOSE,P/N 9439402,7 INCHES LONG.....	1
4	PAOZZ	5340011519956	7X677	14033893	CLAMP,LOOP.....	1
5	PAOZZ	5310000877493	96906	MS27183-13	WASHER,FLAT 3/8.....	2
6	PAOZZ	5306011483667	7X677	11504512	BOLT,MACHINE 10-1.5X16 MM.....	2
7	PAOZZ	5307011509538	15946	22515630	STUD,SHOULDERED.....	1
8	PAOZZ	5340008815303	96906	MS21333-45	CLAMP,LOOP.....	1
9	PAOZZ	4730001506118	19207	11663000	CLAMP,HOSE.....	18
10	MOOZZ		11862	14066305-11	TUBING NONMETALLIC MAKE FROM HOSE, P/N 9439046,11 INCHES LONG..... UOC:AVY,A11,A13,A14,A20,A24,A25,A26,A27,B17,B18,HVY,H11,H13,H14,H17,H18,H20,H21,H24,H25,H26,H27,H28,MMM	1
10	PAOZZ	5340014765585	19207	12338577	PLUG,PROTECTIVE,DUS..... UOC:A15,B15,B16,H15,H16	1
11	PAFZZ	4710011489580	7X677	14033912	TUBE ASSEMBLY,METAL 6.2 LITER,#2 CYLINDER,USE WITH PUMP ASSEMBLY P/N DB2829-4523..... UOC:H11,H13,H14,H15,H16,H17,H18,H20,H21,H24,H25,H26,H27,H28,MMM	1
11	PAFZZ	4710013144483	7X677	10149552	TUBE ASSEMBLY,METAL 6.2 LITER,#2 CYLINDER,USE WITH PUMP ASSEMBLY P/N DB2829-4879..... UOC:AVY,A11,A13,A14,A15,A20,A24,A25,A26,A27,B16,B17,B18,HVY,H11,H13,H14,H15,H16,H17,H18,H20,H21,H24,H25,H26,H27,H28,MMM	1
11	PAFZZ	4710014128611	7X677	14098632	TUBE ASSEMBLY,METAL 6.5 LITER,#2 CYLINDER,USE WITH PUMP ASSEMBLY P/N DB2831-5149 AND DB2831-5209.....	1
12	PAFZZ	4710014121669	7X677	14098634	TUBE ASSEMBLY,METAL 6.5 LITER,#4 CYLINDER, USE WITH PUMP ASSEMBLY P/N DB2831-5149 AND DB2831-5209.....	1
12	PAFZZ	4710011495076	7X677	14033914	TUBE ASSEMBLY,METAL 6.2 LITER,#4 CYLINDER,USE WITH PUMP ASSEMBLY P/N DB2829-4523..... UOC:H11,H13,H14,H15,H16,H17,H18,H20,H21,H24,H25,H26,H27,H28,MMM	1

SECTION II			TM9-2320-280-24P			
(1)	(2)	(3)	(4)	(5)	(6)	(7)
ITEM NO	SMR CODE	NSN	CAGEC	PART NUMBER	DESCRIPTION AND USABLE ON CODES(UC)	QTY
12	PAFZZ	4710013160222	7X677	10149554	TUBE ASSEMBLY,METAL 6.2 LITER,#4 CYLINDER,USE WITH PUMP ASSEMBLY P/N DB2829-4879..... UOC:AVY,A11,A13,A14,A15,A20,A24,A25, A26,A27,B16,B17,B18,HVY,H11,H13,H14, H15,H16,H17,H18,H20,H21,H24,H25,H26, H27,H28,MMM	1
13	PAOZZ	5325011604618	7X677	23503124	GROMMET, NONMETALLIC.....	12
14	PAOZZ	5305011501521	7X677	11503617	SCREW,TAPPING.....	8
15	PAOZZ	5340011506026	7X677	14033955	CLAMP, LOOP.....	4
16	PAFZZ	4710011500971	7X677	14033916	TUBE ASSEMBLY,METAL 6.2 LITER,#6 CYLINDER,USE WITH PUMP ASSEMBLY P/N DB2829-4523..... UOC:H11,H13,H14,H15,H16,H17,H18,H20, H21,H24,H25,H26,H27,H28,MMM	1
16	PAFZZ	4710013144485	7X677	10149556	TUBE ASSEMBLY,METAL 6.2 LITER,#6 CYLINDER,USE WITH PUMP ASSEMBLY P/N DB2829-4879..... UOC:AVY,A11,A13,A14,A15,A20,A24,A25, A26,A27,B16,B17,B18,HVY,H11,H13,H14, H15,H16,H17,H18,H20,H21,H24,H25,H26, H27,H28,MMM	1
16	PAFZZ	4710014118489	7X677	14098636	TUBE ASSEMBLY,METAL 6.5 LITER,#6 CYLINDER,USE WITH PUMP ASSEMBLY P/N DB2831-5149 AND DB2831-5209.....	1
17	PAFZZ	4710014118492	34623	14098638	TUBE ASSEMBLY,METAL 6.5 LITER,#8 CYLINDER,USE WITH PUMP ASSEMBLY P/N DB2831-5149 AND DB2831-5209.....	1
17	PAFZZ	4710011489582	7X677	14033918	TUBE ASSEMBLY,METAL 6.2 LITER,#8 CYLINDER,USE WITH PUMP ASSEMBLY P/N DB2829-4523..... UOC:H11,H13,H14,H15,H16,H17,H18,H20, H21,H24,H25,H26,H27,H28,MMM	1
17	PAFZZ	4710013144484	7X677	10149558	TUBE ASSEMBLY,METAL 6.2 LITER,#8 CYLINDER,USE WITH PUMP ASSEMBLY P/N DB2829-4879..... UOC:AVY,A11,A13,A14,A15,A20,A24,A25, A26,A27,B16,B17,B18,HVY,H11,H13,H14, H15,H16,H17,H18,H20,H21,H24,H25,H26, H27,H28,MMM	1
18	PAFZZ	4710014118488	7X677	14098635	TUBE ASSEMBLY,METAL 6.5 LITER,#5 CYLINDER,USE WITH PUMP ASSEMBLY P/N DB2831-5149 AND DB2831-5209.....	1
18	PAFZZ	4710011531636	7X677	14033915	TUBE ASSEMBLY,METAL 6.2 LITER,#5 CYLINDER,USE WITH PUMP ASSEMBLY P/N DB2829-4523..... UOC:H11,H13,H14,H15,H16,H17,H18,H20, H21,H24,H25,H26,H27,H28,MMM	1
18	PAFZZ	4710013144487	7X677	10149555	TUBE ASSEMBLY,METAL 6.2 LITER,#5 CYLINDER,USE WITH PUMP ASSEMBLY P/N DB2829-4879..... UOC:AVY,A11,A13,A14,A15,A20,A24,A25, A26,A27,B16,B17,B18,HVY,H11,H13,H14,	1

SECTION II			TM9-2320-280-24P			
(1)	(2)	(3)	(4)	(5)	(6)	(7)
ITEM NO	SMR CODE	NSN	CAGEC	PART NUMBER	DESCRIPTION AND USABLE ON CODES(UC)	QTY
					H15,H16,H17,H18,H20,H21,H24,H25,H26, H27,H28,MMM	
19	PAOZZ	5340011504106	7X677	14033921	STRAP,RETAINING.....	3
20	PAOZZ	5340011506275	7X677	14033922	STRAP,RETAINING.....	3
21	PAOZZ	5342011661534	7X677	14066301	CAP.....	2
22	MOOZZ		11862	14066305-7	TUBING,NONMETALLIC MAKE FROM HOSE, P/N 9439046,7 INCHES LONG.....	7
23	PAFZZ	4710014121667	7X677	14098637	TUBE ASSEMBLY,METAL 6.5 LITER #7 USE WITH PUMP ASSEMBLY P/N DB2831-5149 AND DB2831-5209.....	1
23	PAFZZ	4710011495077	7X677	14033917	TUBE ASSEMBLY,METAL 6.2 LITER,#7 CYLINDER,USE WITH PUMP ASSEMBLY P/N DB2829-4523.....	1
					UOC:H11,H13,H14,H15,H16,H17,H18,H20, H21,H24,H25,H26,H27,H28,MMM	
23	PAFZZ	4710013144486	7X677	10149557	TUBE ASSEMBLY,METAL 6.2 LITER,#7 CYLINDER,USE WITH PUMP ASSEMBLY P/N DB2829-4879.....	1
					UOC:AVY,A11,A13,A14,A15,A20,A24,A25, A26,A27,B16,B17,B18,HVY,H11,H13,H14, H15,H16,H17,H18,H20,H21,H24,H25,H26, H27,H28,MMM	
24	PFOZZ	5340011596626	7X677	14033824	BRACKET,DOUBLE ANGL L.H. AND R.H., 6.2 LITER,USE PRIOR TO 1990 ENGINE, PUMP ASSEMBLY P/N DB2829-4523.....	2
					UOC:H11,H13,H14,H15,H16,H17,H18,H20, H21,H24,H25,H26,H27,H28,MMM	
24	PFOZZ	5340011596626	7X677	14033824	BRACKET,DOUBLE ANGL R.H.,6.2 LITER, USE WITH 1990 ENGINE AND ABOVE,PUMP ASSEMBLY P/N DB2829-4879 OR 6.5 LITER P/N DB2831-5149 AND DB2831- 5209.....	1
24	PFOZA	5340014409678	34623	10163716	BRACKET,MOUNTING L.H.,6.2 LITER, USE WITH 1990 ENGINE AND ABOVE,PUMP ASSEMBLY P/N DB2829-4879 OR 6.5 LITER,P/N DB2831-5149 AND DB2831- 5209.....	1
25	PAOZZ	5310008093078	96906	MS27183-11	WASHER,FLAT 1/4.....	5
26	PAOZZ	5310011653331	7X677	22521550	NUT,PLAIN,HEXAGON.....	5
27	PAOZZ	5340011870892	19207	12339890	CLAMP,SPRING TENSION.....	1
					UOC:AVY,A11,A13,A14,A15,A20,A24,A25, A26,A27,BVY,B16,B17,B18,B20,B24,B25, C17,HVY,H11,H13,H14,H16,H17,H18,H20, H21,H24,H25,H26,H27,H28,MMM,NNN	
28	PAFZZ	4710011489581	7X677	14033913	TUBE ASSEMBLY,METAL 6.2 LITER,#3 CYLINDER,USE WITH PUMP ASSEMBLY P/N DB2829-4523.....	1
					UOC:H11,H13,H14,H15,H16,H17,H18,H20, H21,H24,H25,H26,H27,H28,MMM	
28	PAFZZ	4710013144488	7X677	10149553	TUBE ASSEMBLY,METAL 6.2 LITER,#3 CYLINDER,USE WITH PUMP ASSEMBLY P/N DB2829-4879.....	1
					UOC:AVY,A11,A13,A14,A15,A20,A24,A25,	

SECTION II			TM9-2320-280-24P			
(1)	(2)	(3)	(4)	(5)	(6)	(7)
ITEM NO	SMR CODE	NSN	CAGEC	PART NUMBER	DESCRIPTION AND USABLE ON CODES(UC)	QTY
					A26,A27,B16,B17,B18,HVY,H11,H13,H14,H15,H16,H17,H18,H20,H21,H24,H25,H26,H27,H28,MMM	
28	PAFZZ	4710014128615	7X677	14098633	TUBE ASSEMBLY,METAL 6.5 LITER,#3 CYLINDER,USE WITH PUMP ASSEMBLY P/N DB2831-5149 AND DB2831-5209.....	1
29	PAOZZ	5340011507774	7X677	14033953	CLAMP,LOOP L.H.....	1
30	PAFZZ	4710014121668	7X677	14098631	TUBE ASSEMBLY,METAL 6.5 LITER,#1 CYLINDER,USE WITH PUMP ASSEMBLY P/N DB2831-5149 AND DB2831-5209.....	1
30	PAFZZ	4710011495075	7X677	14033911	TUBE ASSEMBLY,METAL 6.2 LITER,#1 CYLINDER,USE WITH PUMP ASSEMBLY P/N DB2829-4523.....	1
					UOC:H11,H13,H14,H15,H16,H17,H18,H20,H21,H24,H25,H26,H27,H28,MMM	
30	PAFZZ	4710013144489	7X677	10149551	TUBE ASSEMBLY,METAL 6.2 LITER,#1 CYLINDER,USE WITH PUMP ASSEMBLY P/N DB2829-4879.....	1
					UOC:AVY,A11,A13,A14,A15,A20,A24,A25,A26,A27,B16,B17,B18,HVY,H11,H13,H14,H15,H16,H17,H18,H20,H21,H24,H25,H26,H27,H28,MMM	
31	PAOZZ	5340011487529	7X677	560613	CLAMP,LOOP.....	4
32	PAOZZ	5340011519957	7X677	14033895	CLAMP,LOOP.....	1

END OF FIGURE

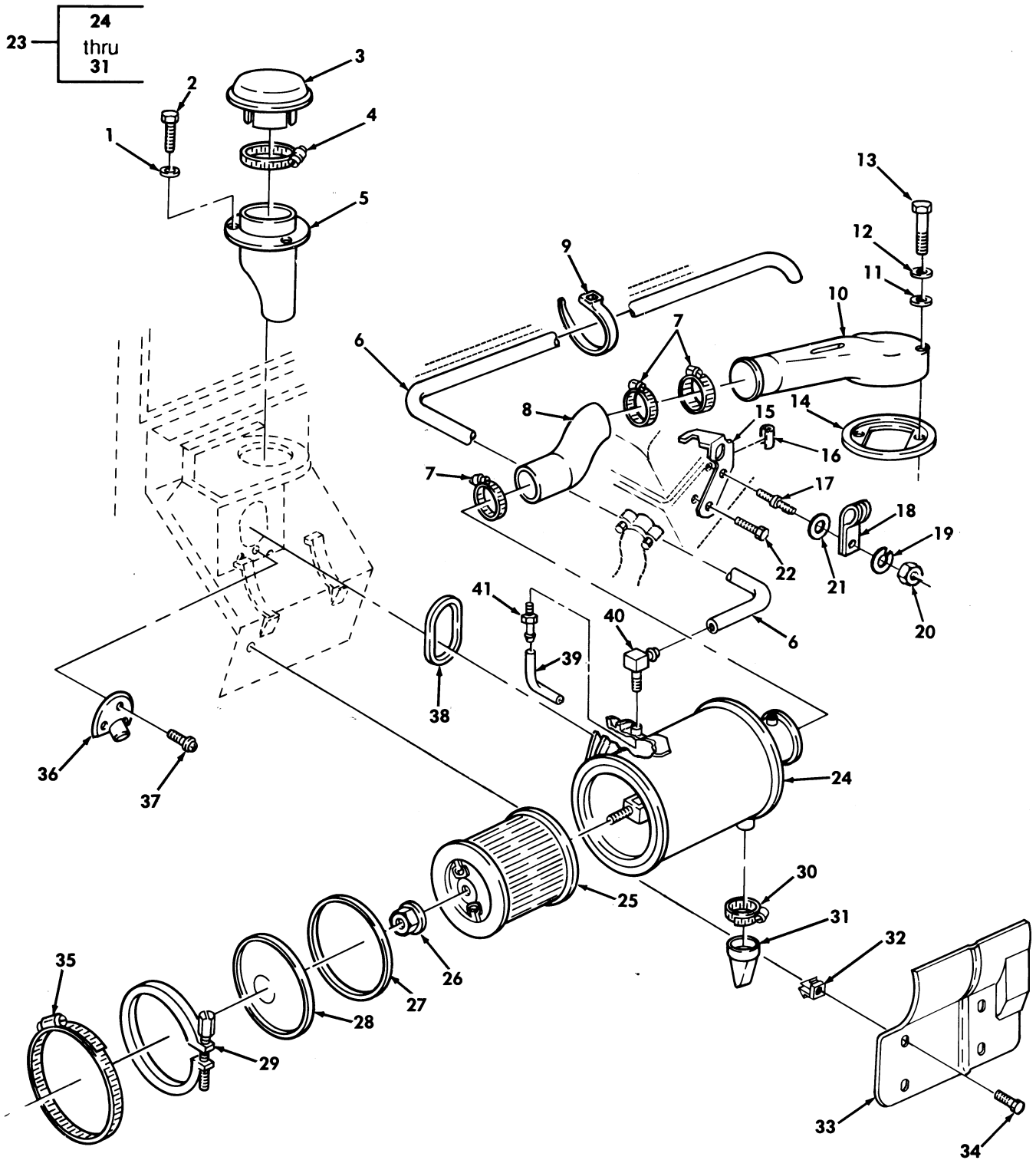

\* FOR DEEP WATER FORDING  
REFER TO GROUP 3305

Figure 12. Air Cleaner, Air Horn, and Related Parts.

SECTION II			TM9-2320-280-24P			
(1)	(2)	(3)	(4)	(5)	(6)	(7)
ITEM NO	SMR CODE	NSN	CAGEC	PART NUMBER	DESCRIPTION AND USABLE ON CODES(UC)	QTY
GROUP 0304 AIR CLEANER						
FIG. 12 AIR CLEANER,AIR HORN,AND RELATED PARTS						
1	PAOZZ	5310008094058	96906	MS27183-10	WASHER,FLAT.....	3
2	PAOZZ	5305011628512	24617	9421073	SCREW,TAPPING.....	3
3	PAOZZ	2940011891809	78940	F-6D9K090B	CAP,AIR CLEANER INT.....	1
4	PAOZZ	4730003599487	66295	C72P	CLAMP,HOSE.....	1
5	PFOZZ	2940011883224	19207	12338373	SHIELD ASSEMBLY.....	1
6	MOOZZ		34623	CPR104420-1-26	TUBE,METALLIC MAKE FROM TUBING,P/N CPR104420-1,26 INCHES LONG..... UOC:A14,A26,A27,B18,H14,H18,H26,H27, H28	1
6	MOOZZ		19207	CPR104420-1-28	TUBE,METALLIC MAKE FROM TUBING,P/N CPR104420-1,28 INCHES LONG..... UOC:AVY,A11,A13,A15,A20,A24,A25,BVY, B15,B16,B17,B20,B24,B25,C17,HVY,H11, H13,H15,H16,H17,H20,H21,H24,H25,MMM, NNN	1
7	PAOZZ	4730011890871	76599	H68SS	CLAMP,HOSE.....	3
8	PAOZZ	4720011858152	19207	12338380	HOSE,PREFORMED..... UOC:AVY,A11,A13,A14,A20,A24,A25,A26, A27,BVY,B16,B17,B18,B20,B24,B25,C17, HVY,H11,H13,H14,H16,H17,H18,H20,H21, H24,H25,H26,H27,H28,MMM,NNN	1
8	PAOZZ	4720012037789	34623	5584588	HOSE,PREFORMED..... UOC:A15,B15,H15	1
9	PAOZZ	5975000742072	96906	MS3367-1-9	STRAP,TIEDOWN,ELECT.....	1
10	PAOZZ	4710012781053	34623	5584559	TUBE,AIR HORN INTAK.....	1
11	PAOZZ	5310011857214	19207	12339052	WASHER,FLAT 5/16.....	2
12	PAOZZ	5310011328275	24617	9418924	WASHER,FLAT 5/16.....	2
13	PAOZZ	5306002258511	96906	MS90725-47	BOLT,MACHINE 5/16-18 X 3.75.....	2
14	PAOZZ	5330012461822	19207	12338382	GASKET.....	1
15	PFOZZ	5340011899861	34623	5590657	BRACE,CORNER.....	1
16	PAOZZ	2590014710236	19207	12339902-13	PROTECTOR,PAINT.....	1
17	PAOZZ	5307011509538	15946	22515630	STUD,SHOULDERED 10-1.5 X 20 MM.....	1
18	PAOZZ	5340001519651	96906	MS21333-129	CLAMP,LOOP.....	1
19	PAFZZ	5310012067306	7X677	11500207	WASHER,LOCK M10.....	1
20	PAOZZ	5310011430512	73342	29520052	NUT M10.....	1
21	PAOZZ	5310012101587	7X677	11500256	WASHER,FLAT #10.....	1
22	PAOZZ	5306011589917	1FH08	DIN933M10X20	BOLT,MACHINE 10-1.5 X 20MM.....	1
23	PAOOO	2940011885117	78940	L-111D30	AIR CLEANER,INTAKE.....	1
24	XAOZZ		78940	L-111DR30-L	.BODY ASSEMBLY.....	1
25	PAOZZ	2940011883776	78940	W-250D53	.FILTER ELEMENT,INTA.....	1
26	PAOZZ	5310012115037	78940	0-952A59	.NUT,PLAIN,HEXAGON 5/16-18.....	1
27	PAOZZ	5330014522474	34623	12342872	.GASKET.....	1
28	PAOZZ	2940011883387	78940	L-563C170	.COVER,AIR CLEANER.....	1
29	PAOZZ	5340011900402	78940	L-223C24	.CLAMP,LOOP.....	1
30	PAOZZ	4730012574905	39428	5416K25	.CLAMP,HOSE.....	1
31	PAOZZ	2520010241273	78940	L-638C2GS	.BOOT,DUST AND MOIST.....	1
32	PAOZZ	5340012088688	34623	5585094	SHIELD,EXPANSION.....	4
33	PAOZZ	2540011964726	19207	12338863	SHIELD,AIR CLEANER.....	1

SECTION II			TM9-2320-280-24P			
(1)	(2)	(3)	(4)	(5)	(6)	(7)
ITEM	SMR			PART		
NO	CODE	NSN	CAGEC	NUMBER	DESCRIPTION AND USABLE ON CODES(UC)	QTY
34	PAOZZ	5305000581082	96906	MS51861-34	SCREW,TAPPING #10-16 X 1/2.....	4
35	PAOZZ	4730012105785	7Z588	HTM-1200	CLAMP,HOSE.....	3
36	PFOZZ	5342011877029	19207	12338842	BRACKET,TUBE,DRAIN.....	1
37	PAOZZ	5305002267237	80205	MS16995-78	SCREW,CAP,SOCKET HE #8-18 X 3/8....	3
38	PAOZZ	5330011880911	19207	12338379	GASKET.....	1
39	PFOZZ	4720012145757	19207	12340799	TUBING,NONMETALLIC.....	1
40	PAOZZ	4730010707680	01989	1069X4	ELBOW,PIPE TO HOSE.....	1
41	PAOZZ	4730011855348	01989	1068X4	ADAPTER,STRAIGHT,PI.....	1

END OF FIGURE

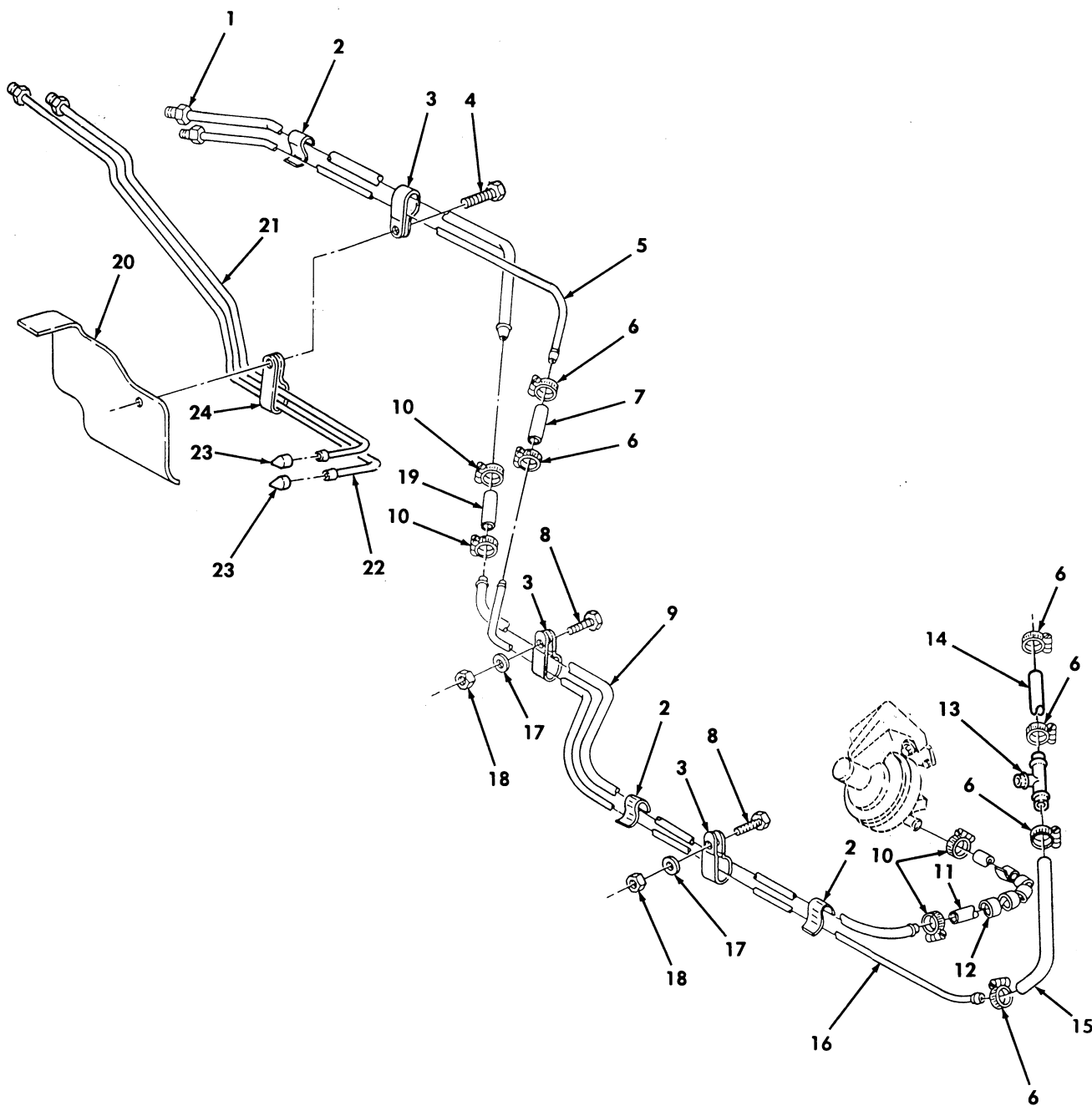

Figure 13. Fuel Tank Supply and Return Lines, (Early Models).



SECTION II			TM9-2320-280-24P			
(1)	(2)	(3)	(4)	(5)	(6)	(7)
ITEM NO	SMR CODE	NSN	CAGEC	PART NUMBER	DESCRIPTION AND USABLE ON CODES(UOC)	QTY
GROUP 0306 TANKS,LINES,FITTINGS, HEADERS						
FIG. 13 FUEL TANK SUPPLY AND RETURN LINES,(EARLY MODELS)						
1	PAOZZ	4710011861009	34623	5584019	TUBE ASSEMBLY,METAL..... UOC:AVY,A11,A13,A14,A15,A20,A24,A25,A26,A27,B16,B17,B18,HVY,H11,H13,H14,H15,H16,H17,H18,H20,H21,H24,H25,H26,H27,H28,MMM	1
2	PAOZZ	5340011870892	19207	12339890	CLIP,SPRING TENSION 3/8 X 1/4..... UOC:AVY,A11,A13,A14,A15,A20,A24,A25,A26,A27,B16,B17,B18,HVY,H11,H13,H14,H15,H16,H17,H18,H20,H21,H24,H25,H26,H27,H28,MMM	3
3	PAOZZ	5340010174630	12603	30H-18	CLAMP,LOOP..... UOC:AVY,A11,A13,A14,A15,A20,A24,A25,A26,A27,B16,B17,B18,HVY,H11,H13,H14,H15,H16,H17,H18,H20,H21,H24,H25,H26,H27,H28,MMM	3
4	PAOZZ	5305012111450	7X677	9415857	SCREW,MACHINE 1/4-20 X 5/8..... UOC:AVY,A11,A13,A14,A15,A20,A24,A25,A26,A27,B16,B17,B18,HVY,H11,H13,H14,H15,H16,H17,H18,H20,H21,H24,H25,H26,H27,H28,MMM	1
5	PAOZZ	4710011861010	34623	5584021	TUBE ASSEMBLY,METAL..... UOC:AVY,A11,A13,A14,A15,A20,A24,A25,A26,A27,B16,B17,B18,HVY,H11,H13,H14,H15,H16,H17,H18,H20,H21,H24,H25,H26,H27,H28,MMM	1
6	PAOZZ	4730011188278	76599	MMF4-SS	CLAMP,HOSE..... UOC:AVY,A11,A13,A14,A15,A20,A24,A25,A26,A27,B16,B17,B18,HVY,H11,H13,H14,H15,H16,H17,H18,H20,H21,H24,H25,H26,H27,H28,MMM	6
7	MOOZZ		34623	5579007	HOSE MAKE FROM HOSE,P/N 9438373,3 INCHES LONG..... UOC:AVY,A11,A13,A14,A15,A20,A24,A25,A26,A27,B16,B17,B18,HVY,H11,H13,H14,H15,H16,H17,H18,H20,H21,H24,H25,H26,H27,H28,MMM	1
8	PAOZZ	5305012067219	92871	G9426241	SCREW,TAPPING 1/4-20 X 3/4..... UOC:AVY,A11,A13,A14,A15,A20,A24,A25,A26,A27,B16,B17,B18,HVY,H11,H13,H14,H15,H16,H17,H18,H20,H21,H24,H25,H26,H27,H28,MMM	2
9	PAOZZ	4710011876759	34623	5584024	TUBE,BENT,METALLIC..... UOC:AVY,A11,A13,A14,A15,A20,A24,A25,A26,A27,B16,B17,B18,HVY,H11,H13,H14,H15,H16,H17,H18,H20,H21,H24,H25,H26,H27,H28,MMM	1
10	PAOZZ	4730000243971	81646	62606	CLAMP,HOSE.....	4

SECTION II			TM9-2320-280-24P			
(1)	(2)	(3)	(4)	(5)	(6)	(7)
ITEM	SMR			PART		
NO	CODE	NSN	CAGEC	NUMBER	DESCRIPTION AND USABLE ON CODES(UOC)	QTY
11	MOOZZ		34623	5578910	UOC:AVY,A11,A13,A14,A15,A20,A24,A25,A26,A27,B16,B17,B18,HVY,H11,H13,H14,H15,H16,H17,H18,H20,H21,H24,H25,H26,H27,H28,MMM HOSE MAKE FROM HOSE,P/N 9438373, 6.5 INCHES LONG.....	1
12	MOOZZ		81349	B47287-II-1/2-3	UOC:AVY,A11,A13,A14,A15,A20,A24,A25,A26,A27,B16,B17,B18,HVY,H11,H13,H14,H15,H16,H17,H18,H20,H21,H24,H25,H26,H27,H28,MMM TUBING,PLASTIC,SPIR MAKE FROM TUBING,P/N B47287-II-1/2,3 INCHES LONG.....	1
13	PAOZZ	4730014760850	79470	1064X6X6X4	UOC:AVY,A11,A13,A14,A15,A20,A24,A25,A26,A27,B16,B17,B18,HVY,H11,H13,H14,H15,H16,H17,H18,H20,H21,H24,H25,H26,H27,H28,MMM TEE,HOSE.....	1
14	MOOZZ		19207	12338560-1	UOC:AVY,A11,A13,A14,A15,A20,A24,A25,A26,A27,B16,B17,B18,HVY,H11,H13,H14,H15,H16,H17,H18,H20,H21,H24,H25,H26,H27,H28,MMM HOSE MAKE FROM HOSE,P/N 9438257, LENGTH AS REQUIRED.....	1
15	MOOZZ		34623	5578911	UOC:AVY,A11,A13,A14,A15,A20,A24,A25,A26,A27,B16,B17,B18,HVY,H11,H13,H14,H15,H16,H17,H18,H20,H21,H24,H25,H26,H27,H28,MMM HOSE MAKE FROM HOSE,P/N 9438257,9 INCHES LONG.....	1
16	PAOZZ	4710011860665	34623	5584023	UOC:AVY,A11,A13,A14,A15,A20,A24,A25,A26,A27,B16,B17,B18,HVY,H11,H13,H14,H15,H16,H17,H18,H20,H21,H24,H25,H26,H27,H28,MMM TUBE,BENT,METALLIC.....	1
17	PAOZZ	5310011023270	24617	2436161	UOC:AVY,A11,A13,A14,A15,A20,A24,A25,A26,A27,B16,B17,B18,HVY,H11,H13,H14,H15,H16,H17,H18,H20,H21,H24,H25,H26,H27,H28,MMM WASHER,FLAT 1/4.....	2
18	PAOZZ	5310000614650	96906	MS51943-31	UOC:AVY,A11,A13,A14,A15,A20,A24,A25,A26,A27,B16,B17,B18,HVY,H11,H13,H14,H15,H16,H17,H18,H20,H21,H24,H25,H26,H27,H28,MMM NUT,SELF-LOCKING,HE 1/4-20.....	2
19	MOOZZ		34623	5579008	UOC:AVY,A11,A13,A14,A15,A20,A24,A25,A26,A27,B16,B17,B18,HVY,H11,H13,H14,H15,H16,H17,H18,H20,H21,H24,H25,H26,H27,H28,MMM HOSE MAKE FROM HOSE,P/N 9438373, 3 INCHES LONG.....	1

SECTION II			TM9-2320-280-24P			
(1)	(2)	(3)	(4)	(5)	(6)	(7)
ITEM	SMR			PART		
NO	CODE	NSN	CAGEC	NUMBER	DESCRIPTION AND USABLE ON CODES(UC)	QTY
20	PFOZZ	2910012106856	19207	12338578	H15,H16,H17,H18,H20,H21,H24,H25,H26, H27,H28,MMM SHIELD,FUEL TANK.....	1
					UOC:AVY,A11,A13,A14,A15,A20,A24,A25, A26,A27,B16,B17,B18,HVY,H11,H13,H14, H15,H16,H17,H18,H20,H21,H24,H25,H26, H27,H28,MMM	
21	PAOZZ	4710013582127	19207	12342748	TUBE ASSEMBLY,METAL AUX FUEL RETURN	1
					UOC:AVY,HVY	
22	PAOZZ	4710013586397	19207	12342747	TUBE ASSEMBLY,METAL AUX FUEL SUPPLY	1
					UOC:AVY,HVY	
23	PAOZZ	4730013578739	19207	12342757	CAP,TUBE.....	2
					UOC:AVY,HVY	
24	PAOZZ	5340010499564	96906	MS21334-25	CLAMP,LOOP.....	1
					UOC:AVY,HVY	

END OF FIGURE

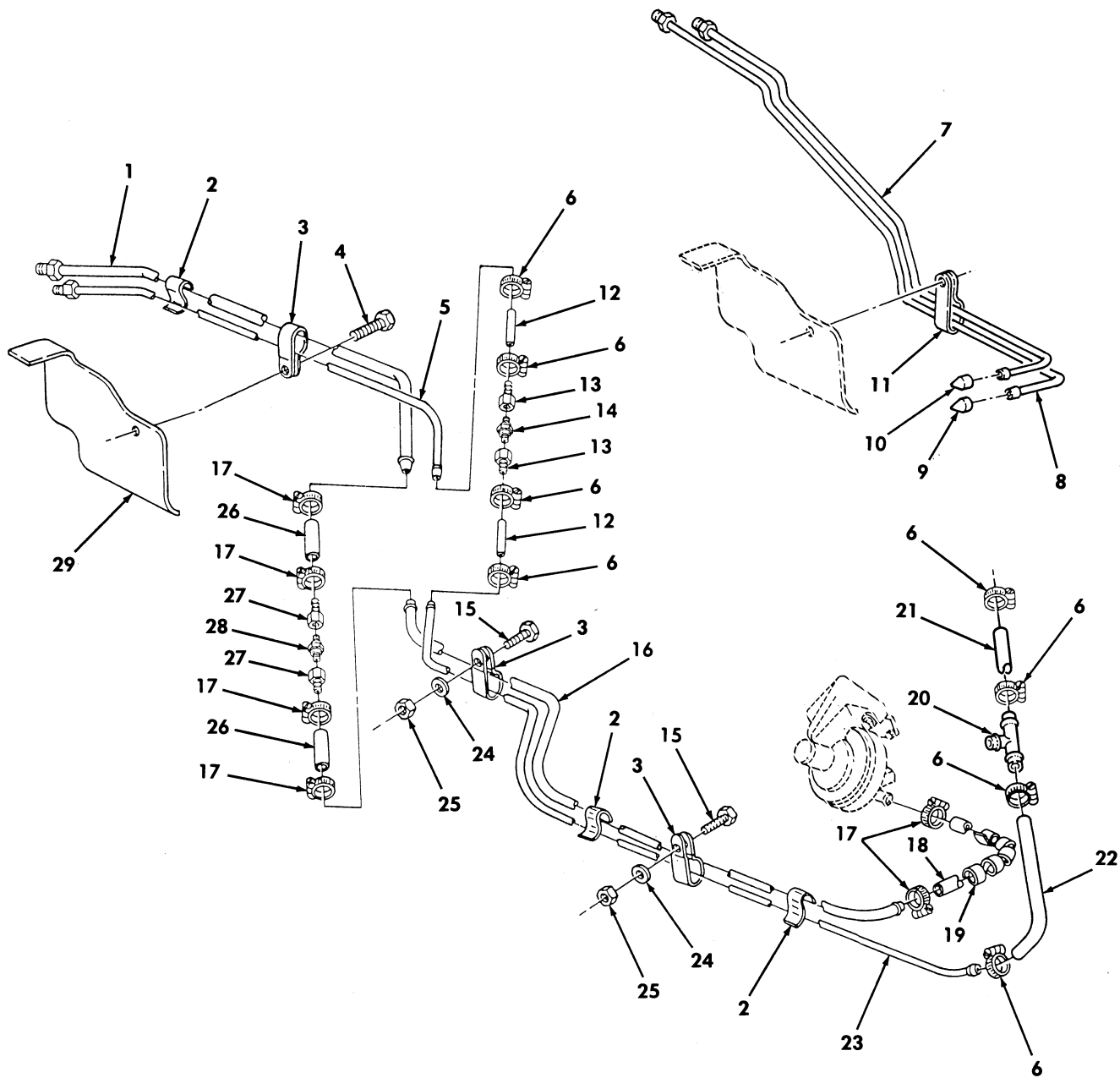

Figure 14. Fuel Tank Supply and Return Lines, (Current Models).

SECTION II			TM9-2320-280-24P			
(1)	(2)	(3)	(4)	(5)	(6)	(7)
ITEM NO	SMR CODE	NSN	CAGEC	PART NUMBER	DESCRIPTION AND USABLE ON CODES(UC)	QTY
GROUP 0306 TANKS,LINES,FITTINGS, HEADERS						
FIG. 14 FUEL TANK SUPPLY AND RETURN LINES,(CURRENT MODELS)						
1	PAOZZ	4710014120273	34623	12342949	TUBE ASSEMBLY,METAL.....	1
2	PAOZZ	5340011870892	19207	12339890	CLIP,SPRING TENSION 3/8 X 1/4.....	3
3	PAOZZ	5340010174630	12603	30H-18	CLAMP,LOOP.....	3
4	PAOZZ	5305012111450	7X677	9415857	SCREW,MACHINE 1/4-20 X 5/8.....	1
5	PAOZZ	4710014131360	34623	12342950	TUBE ASSEMBLY,METAL.....	1
6	PAOZZ	4730011188278	76599	MMF4-SS	CLAMP,HOSE.....	8
7	PAOZZ	4710013582127	19207	12342748	TUBE ASSEMBLY,METAL.....	1
8	PAOZZ	4710013586397	19207	12342747	TUBE ASSEMBLY,METAL.....	1
9	PAOZZ	4730013578739	19207	12342757	CAP,TUBE.....	2
10	PAOZZ	5355012473593	34623	5596249	KNOB.....	1
11	PAOZZ	5340010499564	96906	MS21334-25	CLAMP,LOOP.....	1
12	MOOZZ		19207	12338560-3	HOSE,FUEL RETURN MAKE FROM HOSE,P/ N 9438257,2.25 INCHES LONG.....	2
13	PAOZZ	4730014125216	34623	12342951-1	ADAPTER,STRAIGHT,PI.....	2
14	PAOZZ	4820014304132	91816	2269B-2MM-.5	VALVE,CHECK.....	1
15	PAOZZ	5305012067219	92871	G9426241	SCREW,TAPPING 1/4-20 X 3/4.....	2
16	PAOZZ	4710011876759	34623	5584024	TUBE,BENT,METALLIC.....	1
17	PAOZZ	4730000243971	81646	62606	CLAMP,HOSE.....	6
18	MOOZZ		34623	5578910	HOSE MAKE FROM HOSE,P/N 9438373, 7.75 INCHES LONG.....	1
19	MOOZZ		81349	B47287-II-1/2-3	TUBING,PLASTIC,SPIR MAKE FROM TUBING,P/N B47287-II-1/2,3 INCHES LONG.....	1
20	PAOZZ	4730014760850	79470	1064X6X6X4	TEE,HOSE.....	1
21	MOOZZ		19207	12338560-1	HOSE MAKE FROM HOSE,P/N 9438257, LENGTH AS REQUIRED.....	1
22	MOOZZ		19207	12338560-4	HOSE MAKE FROM HOSE,P/N 9438257,9 INCHES LONG.....	1
23	PAOZZ	4710011860665	34623	5584023	TUBE,BENT,METALLIC.....	1
24	PAOZZ	5310011023270	24617	2436161	WASHER,FLAT 1/4.....	2
25	PAOZZ	5310000614650	96906	MS51943-31	NUT,SELF-LOCKING,HE 1/4-20.....	2
26	MOOZZ		19207	12338561-2	HOSE,FUEL SUPPLY MAKE FROM HOSE,P/N 9438373,2.25 INCHES LONG.....	2
27	PAOZZ	4730014125213	34623	12342951-2	ADAPTER,STRAIGHT,PI.....	2
28	PAOZZ	4820011736883	91816	2269B-2MM-3	VALVE,CHECK.....	1
29	PAOZZ	2910014120047	34623	12460102	SHIELD,FUEL TANK.....	1

END OF FIGURE

1 — 2  
thru  
21

USE WITH BASIC AND A1 VEHICLES

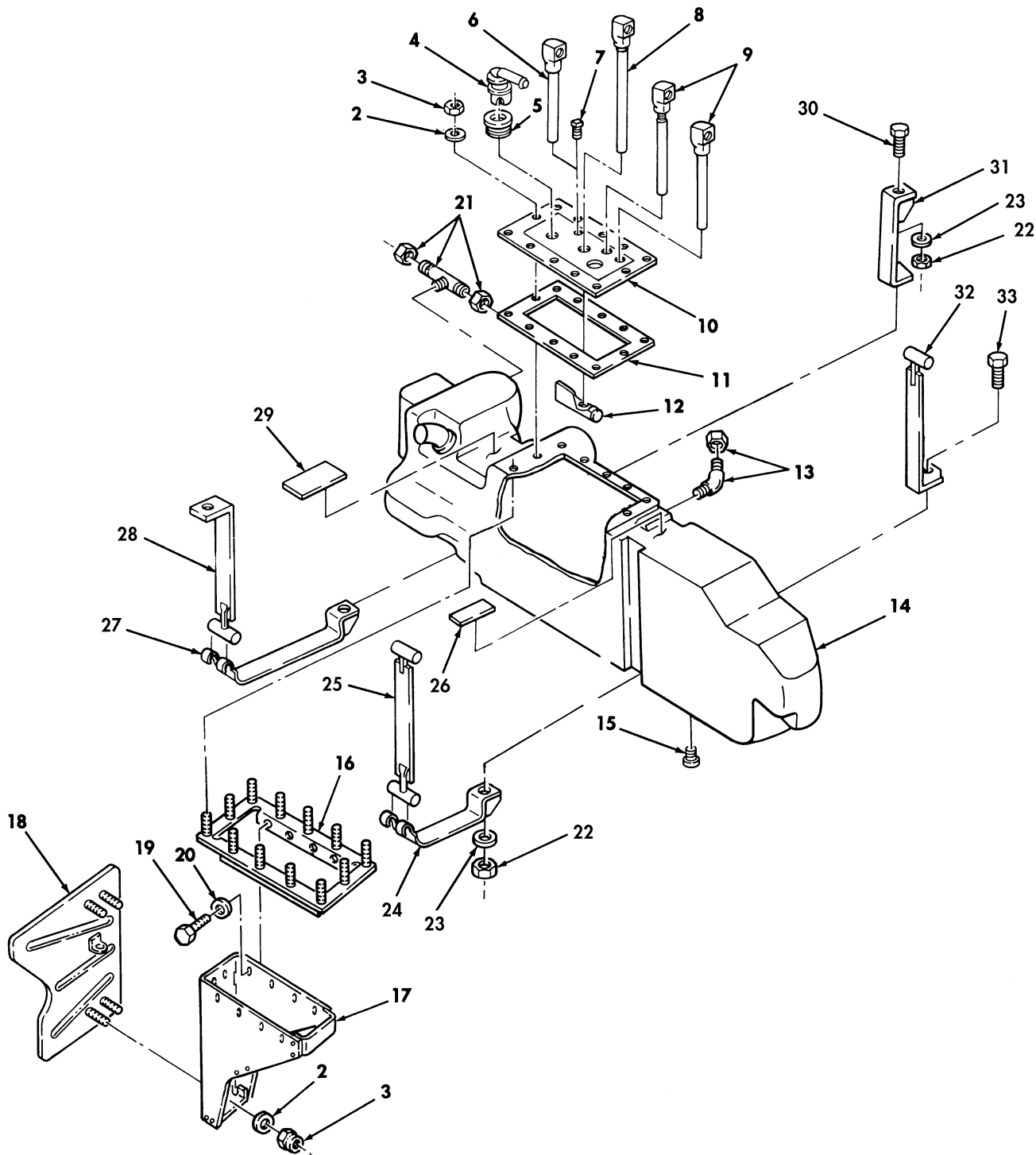

Figure 15. Fuel Tank Assembly and Mounting Straps.

SECTION II			TM9-2320-280-24P			
(1)	(2)	(3)	(4)	(5)	(6)	(7)
ITEM NO	SMR CODE	NSN	CAGEC	PART NUMBER	DESCRIPTION AND USABLE ON CODES(UOC)	QTY
					GROUP 0306 TANKS,LINES,FITTINGS, HEADERS	
					FIG. 15 FUEL TANK ASSEMBLY AND MOUNTING STRAPS	
1	PBOOO	2910011894770	34623	12338579	TANK,FUEL,ENGINE.....	1
					UOC:H11,H13,H14,H15,H16,H17,H18,H20,H21,H24,H25,H26,H27,H28,MMM	
1	PAOOO	2910013578798	34623	12342745	TANK,FUEL,ENGINE.....	1
					UOC:AVY,A11,A13,A14,A15,A20,A24,A25,A26,A27,B16,B17,B18,HVY	
2	PAOZZ	5310011023270	24617	2436161	.WASHER,FLAT 1/4.....	16
					UOC:AVY,A11,A13,A14,A15,A20,A24,A25,A26,A27,B16,B17,B18,HVY,H11,H13,H14,H15,H16,H17,H18,H20,H21,H24,H25,H26,H27,H28,MMM	
3	PAOZZ	5310000614650	96906	MS51943-31	.NUT,SELF-LOCKING,HE 1/4-20.....	16
					UOC:AVY,A11,A13,A14,A15,A20,A24,A25,A26,A27,B16,B17,B18,HVY,H11,H13,H14,H15,H16,H17,H18,H20,H21,H24,H25,H26,H27,H28,MMM	
4	PAOZZ	4820012103488	96152	346-786	.VALVE,VENT.....	1
					UOC:AVY,A11,A13,A14,A15,A20,A24,A25,A26,A27,B16,B17,B18,HVY,H11,H13,H14,H15,H16,H17,H18,H20,H21,H24,H25,H26,H27,H28,MMM	
5	PAOZZ	5325012102870	23040	ELF79B076-B	.GROMMET,NONMETALLIC.....	1
					UOC:AVY,A11,A13,A14,A15,A20,A24,A25,A26,A27,B16,B17,B18,HVY,H11,H13,H14,H15,H16,H17,H18,H20,H21,H24,H25,H26,H27,H28,MMM	
6	PAOZZ	4710013592956	19207	12338548-2	.TUBE ASSEMBLY,METAL.....	1
					UOC:AVY,A11,A13,A14,A15,A20,A24,A25,A26,A27,B16,B17,B18,HVY,H11,H13,H14,H15,H16,H17,H18,H20,H21,H24,H25,H26,H27,H28,MMM	
7	PAOZZ	4730000444577	30780	1-4SHP-S	.PLUG,PIPE 1/4-18.....	1
					UOC:AVY,A11,A13,A14,A15,A20,A24,A25,A26,A27,B16,B17,B18,HVY,H11,H13,H14,H15,H16,H17,H18,H20,H21,H24,H25,H26,H27,H28,MMM	
8	PFOZZ	4710011886050	34623	5574872	.TUBE ASSEMBLY,METAL.....	1
					UOC:AVY,A11,A13,A14,A15,A20,A24,A25,A26,A27,B16,B17,B18,HVY,H11,H13,H14,H15,H16,H17,H18,H20,H21,H24,H25,H26,H27,H28,MMM	
9	PFOZZ	4710011869617	19207	12338549	.TUBE ASSEMBLY,METAL.....	2
					UOC:A15,B16,H11,H13,H14,H15,H16,H17,H18,H20,H21,H24,H25,H26,H27,H28,MMM	
9	PFOZZ	4710011869617	19207	12338549	.TUBE ASSEMBLY,METAL.....	1
					UOC:AVY,A11,A13,A14,A20,A24,A25,A26,A27,B17,B18,HVY	

SECTION II			TM9-2320-280-24P			
(1)	(2)	(3)	(4)	(5)	(6)	(7)
ITEM NO	SMR CODE	NSN	CAGEC	PART NUMBER	DESCRIPTION AND USABLE ON CODES(UOC)	QTY
10	PAOZZ	5340013573996	19207	12342746	. PLATE, MOUNTING..... UOC:AVY, A11, A13, A14, A15, A20, A24, A25, A26, A27, B16, B17, B18, HVY	1
10	PAOZZ	2910011842159	19207	12338567	. PLATE ASSEMBLY, FUEL..... UOC:H11, H13, H14, H15, H16, H17, H18, H20, H21, H24, H25, H26, H27, H28, MMM	1
11	PAOZZ	5330011940473	19207	12338585	. GASKET..... UOC:AVY, A11, A13, A14, A15, A20, A24, A25, A26, A27, B16, B17, B18, HVY, H11, H13, H14, H15, H16, H17, H18, H20, H21, H24, H25, H26, H27, H28, MMM	1
12	PAOZZ	4730011898854	80463	25055210	. STRAINER BODY, SEDIM..... UOC:AVY, A11, A13, A14, A15, A20, A24, A25, A26, A27, B16, B17, B18, HVY, H11, H13, H14, H15, H16, H17, H18, H20, H21, H24, H25, H26, H27, H28, MMM	1
13	PAOZZ	4730010912809	93061	279NTA-8-6	. ELBOW, PIPE TO TUBE..... UOC:AVY, A11, A13, A14, A15, A20, A24, A25, A26, A27, B16, B17, B18, HVY, H11, H13, H14, H15, H16, H17, H18, H20, H21, H24, H25, H26, H27, H28, MMM	1
14	XAOZZ		34623	5582606	. TANK ASSEMBLY..... UOC:AVY, A11, A13, A14, A15, A20, A24, A25, A26, A27, B16, B17, B18, HVY, H11, H13, H14, H15, H16, H17, H18, H20, H21, H24, H25, H26, H27, H28, MMM	1
15	PAOZZ	5340012445765	34623	5597286	. PLUG, PROTECTIVE, DUS..... UOC:AVY, A11, A13, A14, A15, A20, A24, A25, A26, A27, B16, B17, B18, HVY, H11, H13, H14, H15, H16, H17, H18, H20, H21, H24, H25, H26, H27, H28, MMM	1
16	PFOZZ	2910011866038	34623	5584341	. RETAINER, FUEL TANK..... UOC:AVY, A11, A13, A14, A15, A20, A24, A25, A26, A27, B16, B17, B18, HVY, H11, H13, H14, H15, H16, H17, H18, H20, H21, H24, H25, H26, H27, H28, MMM	1
17	XAOZZ		19207	12342935	. SUPPORT ASST, BAFFLE..... UOC:AVY, A11, A13, A14, A15, A20, A24, A25, A26, A27, B16, B17, B18, HVY, H11, H13, H14, H15, H16, H17, H18, H20, H21, H24, H25, H26, H27, H28, MMM	1
18	XAOZZ		19207	12342938	. BAFFLE ASSY FUEL TA..... UOC:AVY, A11, A13, A14, A15, A20, A24, A25, A26, A27, B16, B17, B18, HVY, H11, H13, H14, H15, H16, H17, H18, H20, H21, H24, H25, H26, H27, H28, MMM	1
19	PAOZZ	5305000680508	80204	B1821BH025C075N	. SCREW, CAP, HEXAGON H 1/4-20 X .075. UOC:AVY, A11, A13, A14, A15, A20, A24, A25, A26, A27, B16, B17, B18, HVY, H11, H13, H14, H15, H16, H17, H18, H20, H21, H24, H25, H26, H27, H28, MMM	4
20	PAOZZ	5310000806004	96906	MS27183-9	. WASHER, FLAT 3/8..... UOC:AVY, A11, A13, A14, A15, A20, A24, A25,	4



SECTION II			TM9-2320-280-24P			
(1)	(2)	(3)	(4)	(5)	(6)	(7)
ITEM	SMR			PART		
NO	CODE	NSN	CAGEC	NUMBER	DESCRIPTION AND USABLE ON CODES(UOC)	QTY
21	PAOZZ	4730011196895	93061	272NTA-8-6	A26,A27,B16,B17,B18,HVY,H11,H13,H14, H15,H16,H17,H18,H20,H21,H24,H25,H26, H27,H28,MMM .TEE,PIPE TO TUBE.....	1
					UOC:AVY,A11,A13,A14,A15,A20,A24,A25, A26,A27,B16,B17,B18,HVY,H11,H13,H14, H15,H16,H17,H18,H20,H21,H24,H25,H26, H27,H28,MMM	
22	PAOZZ	5310007610654	96906	MS51967-9	NUT,PLAIN,HEXAGON.....	2
					UOC:AVY,A11,A13,A14,A15,A20,A24,A25, A26,A27,B16,B17,B18,HVY,H11,H13,H14, H15,H16,H17,H18,H20,H21,H24,H25,H26, H27,H28,MMM	
23	PAOZZ	5310014124013	24617	2436163	WASHER,FLAT.....	1
					UOC:AVY,A11,A13,A14,A15,A20,A24,A25, A26,A27,B16,B17,B18,HVY,H11,H13,H14, H15,H16,H17,H18,H20,H21,H24,H25,H26, H27,H28,MMM	
24	PAOZZ	5340011910748	19207	12338571	BAND,RETAINING BOTTOM FRONT.....	1
					UOC:AVY,A11,A13,A14,A15,A20,A24,A25, A26,A27,B16,B17,B18,HVY,H11,H13,H14, H15,H16,H17,H18,H20,H21,H24,H25,H26, H27,H28,MMM	
25	PAOZZ	5340011910746	19207	12338573	BAND,RETAINING OUTER FRONT.....	1
					UOC:AVY,A11,A13,A14,A15,A20,A24,A25, A26,A27,B16,B17,B18,HVY,H11,H13,H14, H15,H16,H17,H18,H20,H21,H24,H25,H26, H27,H28,MMM	
26	PAOZZ	5330011875148	19207	12338557-2	RUBBER STRIP FRONT.....	1
					UOC:AVY,A11,A13,A14,A15,A20,A24,A25, A26,A27,B16,B17,B18,HVY,H11,H13,H14, H15,H16,H17,H18,H20,H21,H24,H25,H26, H27,H28,MMM	
27	PAOZZ	5340011905100	19207	12338574	STRAP,RETAINING BOTTOM REAR.....	1
					UOC:AVY,A11,A13,A14,A15,A20,A24,A25, A26,A27,B16,B17,B18,HVY,H11,H13,H14, H15,H16,H17,H18,H20,H21,H24,H25,H26, H27,H28,MMM,	
28	PAOZZ	5340011930251	19207	12338575	BRACKET,ANGLE OUTER REAR.....	1
					UOC:AVY,A11,A13,A14,A15,A20,A24,A25, A26,A27,B16,B17,B18,HVY,H11,H13,H14, H15,H16,H17,H18,H20,H21,H24,H25,H26, H27,H28,MMM	
29	PAOZZ	5330011867757	19207	12338557-1	RUBBER STRIP REAR.....	1
					UOC:AVY,A11,A13,A14,A15,A20,A24,A25, A26,A27,B16,B17,B18,HVY,H11,H13,H14, H15,H16,H17,H18,H20,H21,H24,H25,H26, H27,H28,MMM	
30	PAOZZ	5305000680510	80204	B1821BH038C100N	SCREW,CAP,HEXAGON H 3/8-16 X 1.00..	2
					UOC:AVY,A11,A13,A14,A15,A20,A24,A25, A26,A27,B16,B17,B18,HVY,H11,H13,H14, H15,H16,H17,H18,H20,H21,H24,H25,H26, H27,H28,MMM	

SECTION II			TM9-2320-280-24P			
(1)	(2)	(3)	(4)	(5)	(6)	(7)
ITEM	SMR			PART		
NO	CODE	NSN	CAGEC	NUMBER	DESCRIPTION AND USABLE ON CODES(UC)	QTY
31	PAOZZ	5340011869606	19207	12338568	BAND,RETAINING..... UOC:AVY,A11,A13,A14,A15,A20,A24,A25, A26,A27,B16,B17,B18,HVY,H11,H13,H14, H15,H16,H17,H18,H20,H21,H24,H25,H26, H27,H28,MMM	1
32	PAOZZ	5340011913526	19207	12338570	BAND,RETAINING..... UOC:AVY,A11,A13,A14,A15,A20,A24,A25, A26,A27,B16,B17,B18,HVY,H11,H13,H14, H15,H16,H17,H18,H20,H21,H24,H25,H26, H27,H28,MMM	1
33	PAOZZ	5305012106251	7X677	9425078	SCREW,CAP,HEXAGON H 3/8-16 X 1.62.. UOC:AVY,A11,A13,A14,A15,A20,A24,A25, A26,A27,B16,B17,B18,HVY,H11,H13,H14, H15,H16,H17,H18,H20,H21,H24,H25,H26, H27,H28,MMM	2

END OF FIGURE

USE WITH A2 VEHICLES

1  
2  
thru  
16

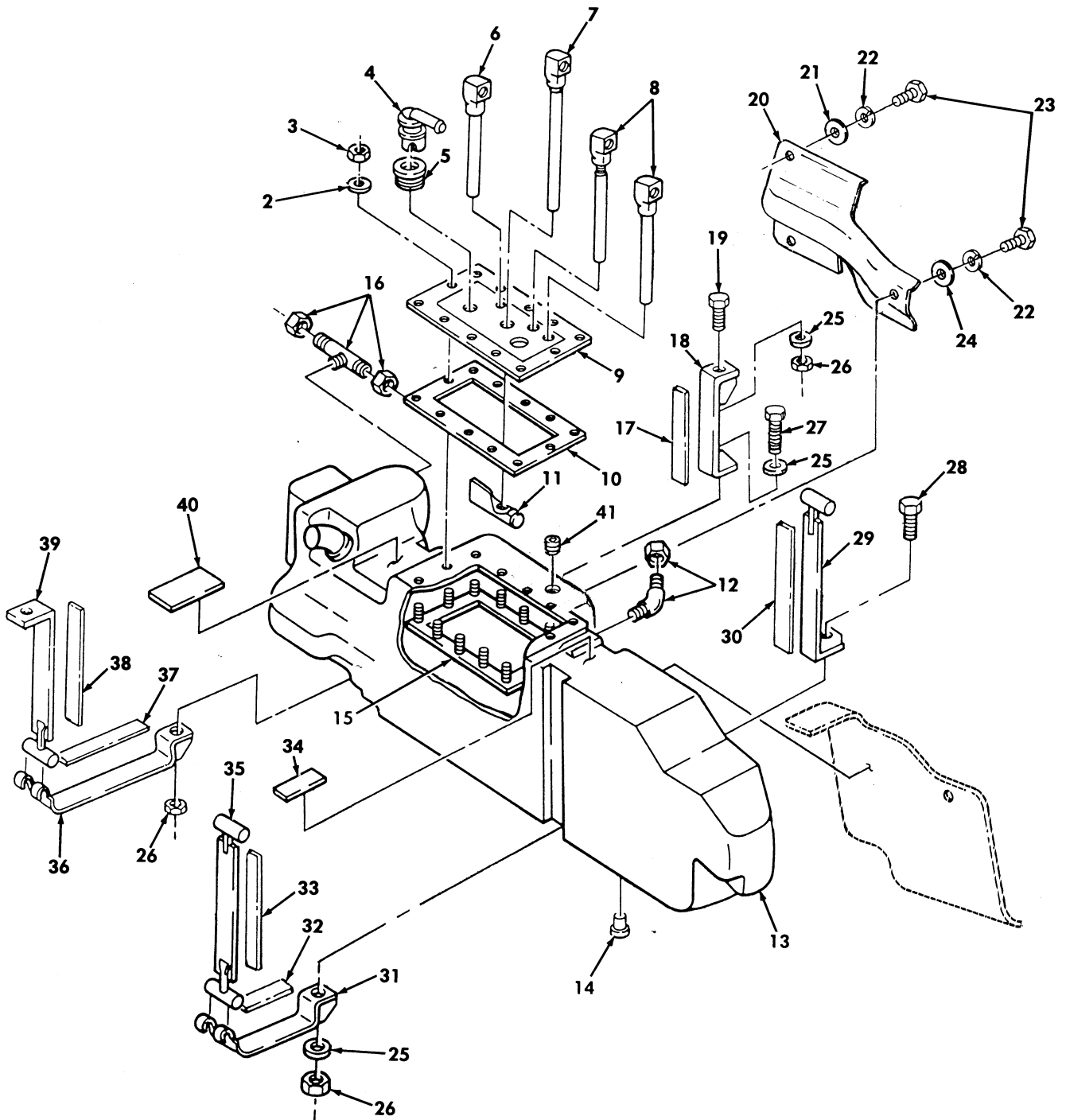
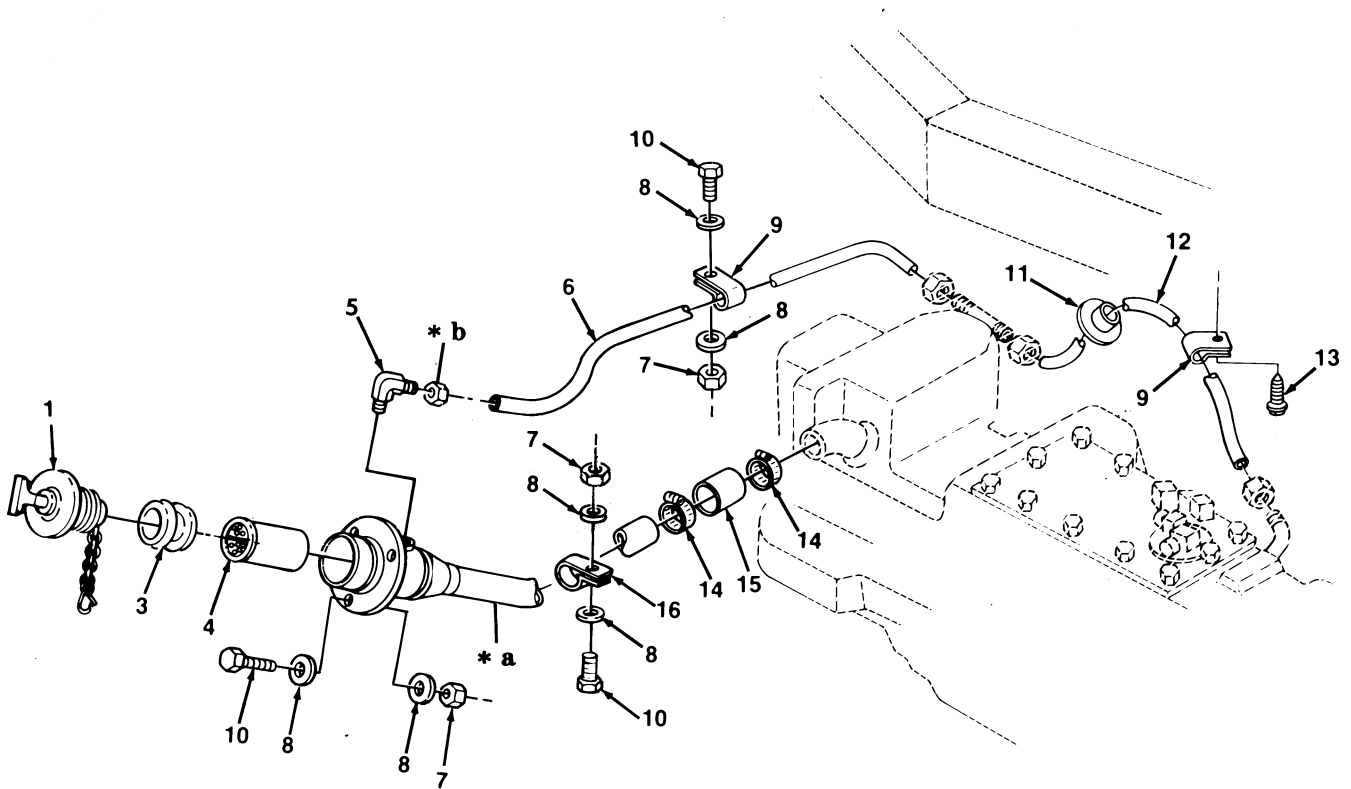
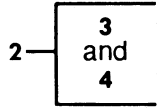

Figure 16. Fuel Tank Assembly and Mounting Straps.

SECTION II			TM9-2320-280-24P			
(1)	(2)	(3)	(4)	(5)	(6)	(7)
ITEM NO	SMR CODE	NSN	CAGEC	PART NUMBER	DESCRIPTION AND USABLE ON CODES(UCO)	QTY
GROUP 0306 0015 TANK ASSEMBLY AND HEADERS						
FIG. 16 FUEL TANK ASSEMBLY AND MOUNTING STRAPS						
1	PAOOO	2910014112124	34623	12460104	TANK, FUEL, ENGINE.....	1
					UCO: BVY, B15, B20, B24, B25, C17, NNN	
2	PAOZZ	5310011023270	24617	2436161	. WASHER, FLAT 1/4.....	12
					UCO: BVY, B15, B20, B24, B25, C17, NNN	
3	PAOZZ	5310000614650	96906	MS51943-31	. NUT, SELF-LOCKING, HE 1/4-20.....	12
					UCO: BVY, B15, B20, B24, B25, C17, NNN	
4	PAOZZ	4820012103488	96152	346-786	. VALVE, VENT.....	1
					UCO: BVY, B15, B20, B24, B25, C17, NNN	
5	PAOZZ	5325012102870	23040	ELF79B076-B	. GROMMET, NONMETALLIC.....	1
					UCO: BVY, B15, B20, B24, B25, C17, NNN	
6	PAOZZ	4710013592956	19207	12338548-2	. TUBE ASSEMBLY, METAL.....	1
					UCO: BVY, B15, B20, B24, B25, C17, NNN	
7	PFOZZ	4710011886050	34623	5574872	. TUBE ASSEMBLY, METAL.....	1
					UCO: BVY, B15, B20, B24, B25, C17, NNN	
8	PAOZZ	4710011869617	19207	12338549	. TUBE ASSEMBLY, METAL.....	2
					UCO: BVY, B15, B20, B24, B25, C17, NNN	
9	PAOZZ	5340013573996	19207	12342746	. PLATE, MOUNTING.....	1
					UCO: BVY, B15, B20, B24, B25, C17, NNN	
10	PAOZZ	5330011940473	19207	12338585	. GASKET.....	1
					UCO: BVY, B15, B20, B24, B25, C17, NNN	
11	PAOZZ	4730011898854	80463	25055210	. STRAINER BODY, SEDIM.....	1
					UCO: BVY, B15, B20, B24, B25, C17, NNN	
12	PAOZZ	4730010912809	93061	279NTA-8-6	. ELBOW, PIPE TO TUBE.....	1
					UCO: BVY, B15, B20, B24, B25, C17, NNN	
13	PAOZZ	2910014473911	34623	12460105	. TANK, FUEL, ENGINE.....	1
					UCO: BVY, B15, B20, B24, B25, C17, NNN	
14	PAOZZ	5340012445765	34623	5597286	. PLUG, PROTECTIVE, DUS.....	1
					UCO: BVY, B15, B20, B24, B25, C17, NNN	
15	PAOZA	5340014692979	19207	12460140	. PLATE, MOUNTING.....	1
					UCO: BVY, B15, B20, B24, B25, C17, NNN	
16	PAOZZ	4730011196895	93061	272NTA-8-6	. TEE, PIPE TO TUBE.....	1
					UCO: BVY, B15, B20, B24, B25, C17, NNN	
17	MOOZZ		19207	12460108-5	SEAL, NONMETALLIC CH MAKE FROM SEAL, P/N 12460108-3, LENGTH AS REQUIRED...	1
					UCO: BVY, B15, B20, B24, B25, C17, NNN	
18	PAOZZ	5340011869606	19207	12338568	BAND, RETAINING.....	1
					UCO: BVY, B15, B20, B24, B25, C17, NNN	
19	PAOZZ	5305000680510	80204	B1821BH038C100N	SCREW, CAP, HEXAGON H 3/8-16 X 1.00..	2
					UCO: BVY, B15, B20, B24, B25, C17, NNN	
20	PAOZZ	2510014443360	34623	12460143	SHIELD, SAFETY, FUEL.....	1
					UCO: BVY, B15, B20, B24, B25, C17, NNN	
21	PAOZZ	5310008094058	96906	MS27183-10	WASHER, FLAT 1/4.....	1
					UCO: BVY, B15, B20, B24, B25, C17, NNN	
22	PAOZZ	5310006379541	96906	MS35338-46	WASHER, LOCK 1/4.....	3
					UCO: BVY, B15, B20, B24, B25, C17, NNN	
23	PAOZZ	5305012111450	7X677	9415857	SCREW, MACHINE 1/4-28 X .62.....	3
					UCO: BVY, B15, B20, B24, B25, C17, NNN	

SECTION II			TM9-2320-280-24P			
(1)	(2)	(3)	(4)	(5)	(6)	(7)
ITEM NO	SMR CODE	NSN	CAGEC	PART NUMBER	DESCRIPTION AND USABLE ON CODES(UC)	QTY
24	PAOZZ	5310000806004	96906	MS27183-14	WASHER, FLAT 3/8..... UC:BVY, B15, B20, B24, B25, C17, NNN	3
25	PAOZZ	5310001670893	19207	12341718	WASHER, FLAT..... UC:BVY, B15, B20, B24, B25, C17, NNN	3
26	PAOZZ	5310007610654	96906	MS51967-9	NUT, PLAIN, HEXAGON 3/8-16..... UC:BVY, B15, B20, B24, B25, C17, NNN	4
27	PAOZZ	5306014112338	19207	12460145-1	BOLT, MACHINE..... UC:BVY, B15, B20, B24, B25, C17, NNN	1
28	PAOZZ	5305014125995	19207	12460145-2	SCREW, CAP, HEXAGON H..... UC:BVY, B15, B20, B24, B25, C17, NNN	2
29	PAOZZ	5340014085851	34623	6000300	BAND, RETAINING..... UC:BVY, B15, B20, B24, B25, C17, NNN	1
30	MOOZZ		34623	6000333	SEAL, NONMETALLIC CH MAKE FROM SEAL, P/N 12460108-3, 9.20 INCHES LONG..... UC:BVY, B15, B20, B24, B25, C17, NNN	1
31	PAOZZ	5340011910748	19207	12338571	BAND, RETAINING..... UC:BVY, B15, B20, B24, B25, C17, NNN	1
32	MOOZZ		34623	6000334	SEAL, NONMETALLIC CH MAKE FROM SEAL, P/N 12460108-3, 7.70 INCHES LONG..... UC:BVY, B15, B20, B24, B25, C17, NNN	1
33	MOOZZ		19207	12460108-3-AR	SEAL, NONMETALLIC CH MAKE FROM SEAL , P/N 12460108-3, LENGTH TO SUIT..... UC:BVY, B15, B20, B24, B25, C17, NNN	1
34	PAOZZ	5330011875148	19207	12338557-2	RUBBER STRIP..... UC:BVY, B15, B20, B24, B25, C17, NNN	1
35	PAOZZ	5340011910746	34623	5582412	BAND, RETAINING..... UC:BVY, B15, B20, B24, B25, C17, NNN	1
36	PAOZZ	5340011905100	19207	12338574	STRAP, RETAINING..... UC:BVY, B15, B20, B24, B25, C17, NNN	1
37	MOOZZ		34623	6000331	SEAL, NONMETALLIC CH MAKE FROM SEAL, P/N 12460108-3, 9.85 INCHES LONG..... UC:BVY, B15, B20, B24, B25, C17, NNN	1
38	MOOZZ		34623	6000329	SEAL, NONMETALLIC CH MAKE FROM SEAL, P/N 12460108-3, LENGTH TO SUIT UC:BVY, B15, B20, B24, B25, C17, NNN	1
39	PAOZZ	5340011930251	19207	12338575	BRACKET, ANGLE..... UC:BVY, B15, B20, B24, B25, C17, NNN	1
40	PAOZZ	5330011867757	19207	12338557-1	RUBBER STRIP..... UC:BVY, B15, B20, B24, B25, C17, NNN	1

END OF FIGURE



- \* a PART OF ITEM 2
- \* b PART OF ITEM 5

Figure 17. Fuel Filter Pipe Assembly and Vent Lines.

SECTION II			TM9-2320-280-24P			
(1)	(2)	(3)	(4)	(5)	(6)	(7)
ITEM	SMR			PART		
NO	CODE	NSN	CAGEC	NUMBER	DESCRIPTION AND USABLE ON CODES(UC)	QTY
					GROUP 0306 TANKS,LINES,FITTINGS, HEADERS	
					FIG. 17 FUEL FILLER PIPE ASSEMBLY AND VENT LINES	
1	PAOZZ	5342012461120	0U276	41945	CAP,FILLER OPENING.....	1
2	PFOZZ	2590011883267	34623	12338580	FILLER NECK.....	1
3	PAOZZ	5325011940562	34623	12339296	.GROMMET, NONMETALLIC.....	1
4	PFOZZ	4730013114294	19207	12342096	.STRAINER ELEMENT, SE.....	1
5	PAOZZ	4730002783828	55469	A34	ELBOW, PIPE TO TUBE.....	1
6	MOOZZ		34623	5577552	TUBE MAKE FROM HOSE, P/N PFT-8B-BLK, 45 INCHES LONG.....	1
7	PAOZZ	5310000614650	96906	MS51943-31	NUT, SELF-LOCKING, HE 1/4-20.....	5
8	PAOZZ	5310011023270	24617	2436161	WASHER, FLAT 1/4.....	10
9	PAOZZ	5340003858820	75272	COV-0909	CLAMP, LOOP.....	2
10	PAOZZ	5305000680508	80204	B1821BH025C075N	SCREW, CAP, HEXAGON H 1/4-20 X 3/4...	5
11	PAOZZ	5975012113142	28520	SB-750-625-2840	BUSHING, ELECTRICAL.....	1
12	MOOZZ		34623	5573534	TUBE MAKE FROM HOSE, P/N PFT-8B-BLK, 27 INCHES LONG.....	1
13	PAOZZ	5305012067219	92871	G9426241	SCREW, TAPPING 1/4-14 X 1/2.....	1
14	PAOZZ	4730009098627	76599	36HSS	CLAMP, HOSE.....	2
15	PAOZZ	4720012128269	19207	12338551-2	HOSE, NONMETALLIC.....	1
16	PAOZZ	5340012100692	75272	COV-3311	CLAMP, LOOP.....	1

END OF FIGURE

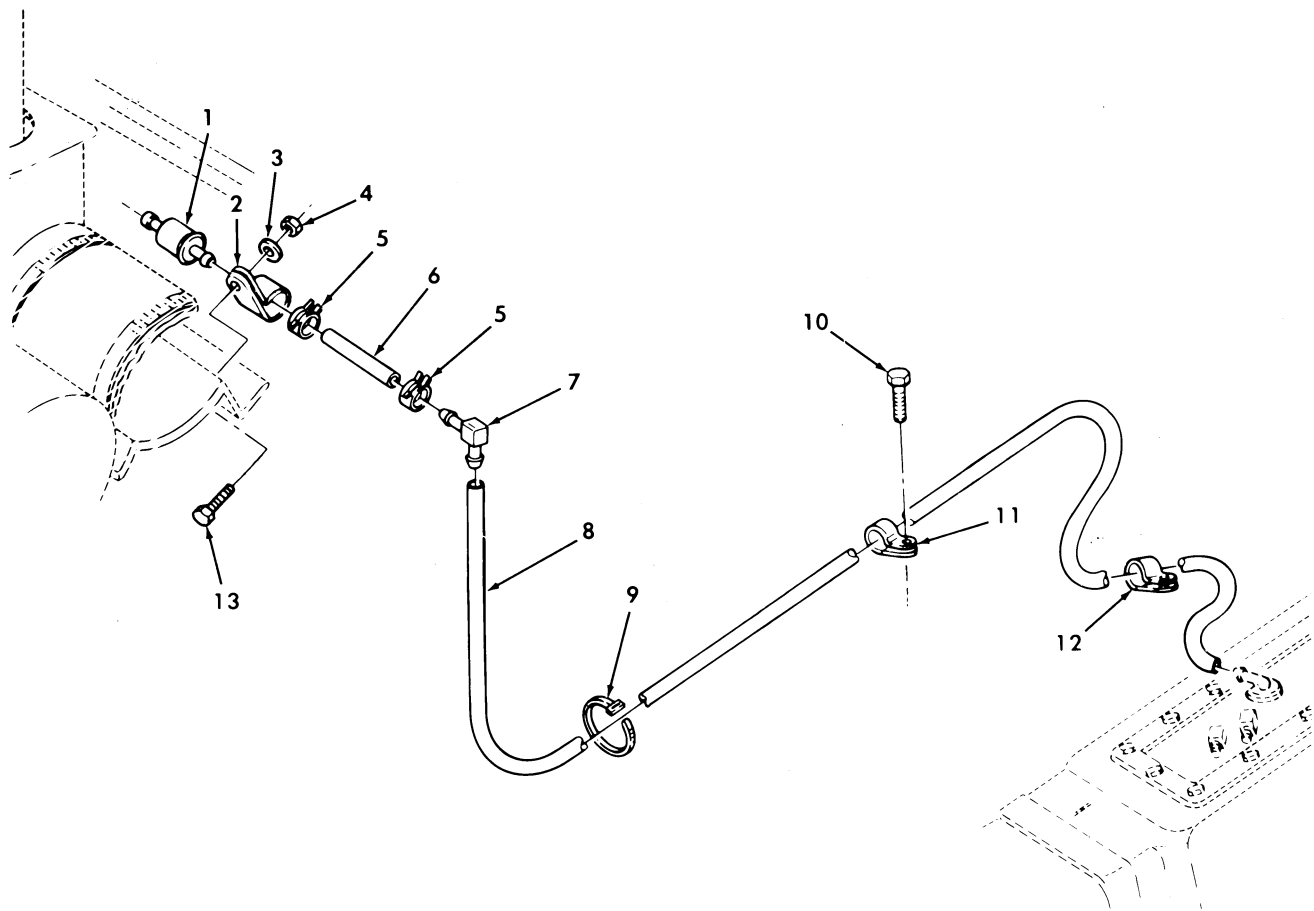

Figure 18. Fuel Tank Vent Line, Filter, and Mounting Hardware.



SECTION II			TM9-2320-280-24P			
(1)	(2)	(3)	(4)	(5)	(6)	(7)
ITEM NO	SMR CODE	NSN	CAGEC	PART NUMBER	DESCRIPTION AND USABLE ON CODES(UC)	QTY
					GROUP 0306 TANKS,LINES FITTINGS, HEADERS	
					FIG. 18 FUEL TANK VENT LINE,FILTER, AND MOUNTING HARDWARE	
1	PAOZZ	2910012105872	19207	12339208	FILTER,FLUID.....	1
2	PAOZZ	5340011018262	75272	COV-1309	CLAMP,LOOP.....	1
3	PAOZZ	5310008238804	96906	MS27183-9	WASHER,FLAT 1/4.....	1
4	PAOZZ	5310000614650	96906	MS51943-31	NUT,SELF-LOCKING,HE 1/4-20.....	1
5	PAOZZ	4730009541251	34623	934245	CLAMP,HOSE.....	2
6	MOOZZ		34623	5591180	HOSE,NONMETALLIC MAKE FROM HOSE,P/N RB1450-1-4IDX1-20D,2 INCHES LONG....	1
7	PAOZZ	4730012110896	01989	1065X6	ELBOW,HOSE.....	1
8	MOOZZ		34623	5594083	TUBE,NONMETALLIC MAKE FROM HOSE,P/N PFT-6B,91 INCHES LONG.....	1
9	PAOZZ	5975005709598	96906	MS3367-7-9	STRAP,TIEDOWN,ELECT.....	1
10	PAOZZ	5310000614650	96906	MS51943-31	NUT,SELF-LOCKING,HE 3/8-16 X .62...	2
11	PAOZZ	5340009546014	96906	MS21333-121	CLAMP,LOOP.....	2
12	PAOZZ	5340010712047	75272	COVO709Z1	HOOK,SUPPORT.....	1
13	PAOZZ	5305000680501	96906	MS90725-5	SCREW,CAP,HEXAGON H 1/4-20 X 5/8...	1

END OF FIGURE

1 — 2  
thru  
9

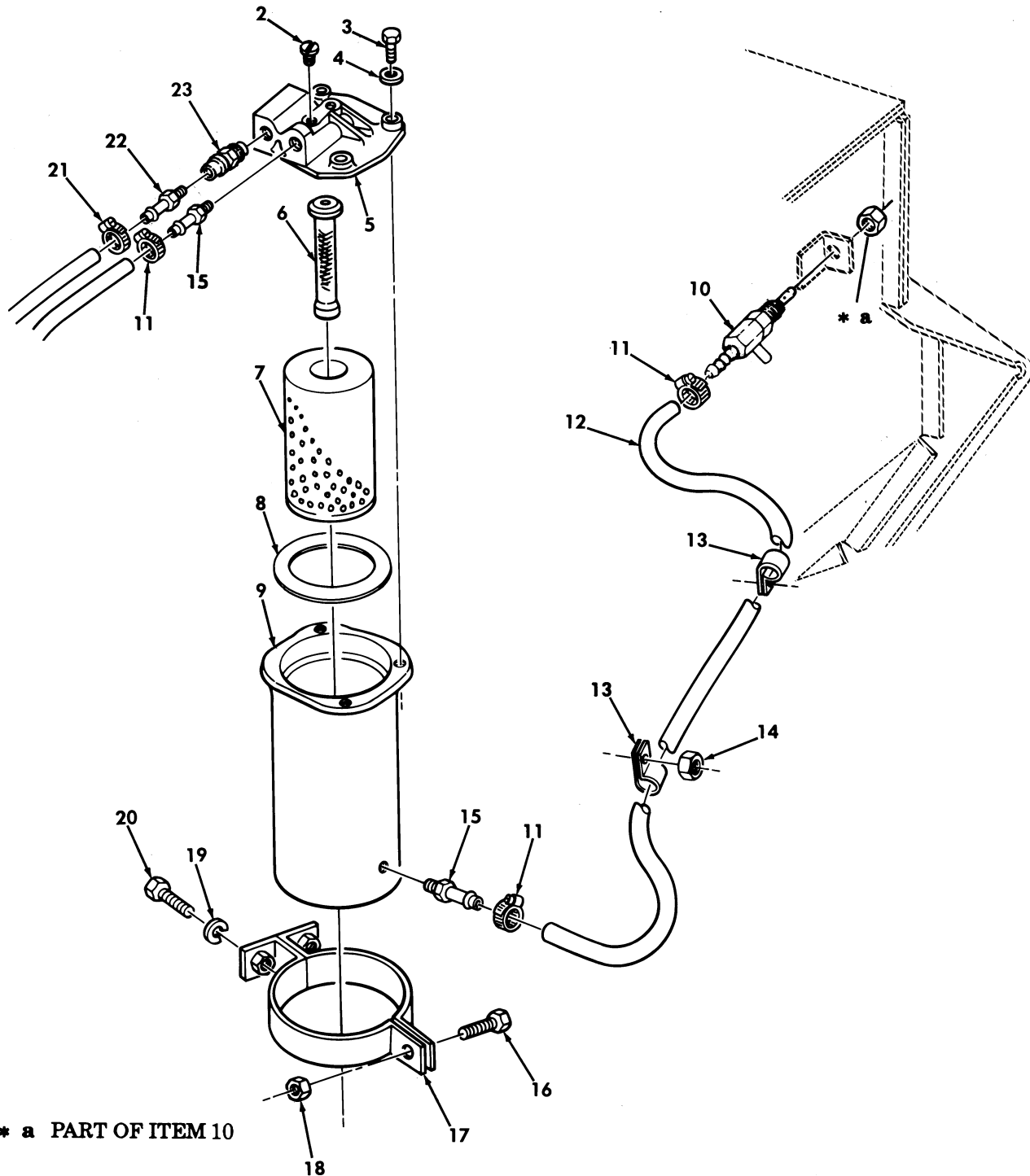
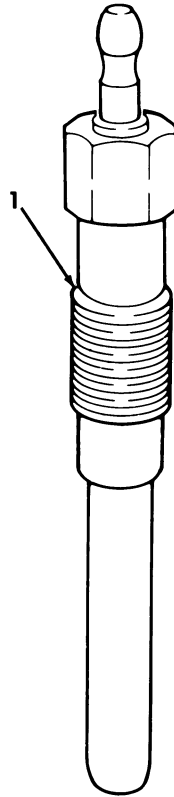

Figure 19. Fuel Filter Assembly/Water Separator and Mounting Hardware.

SECTION II			TM9-2320-280-24P			
(1)	(2)	(3)	(4)	(5)	(6)	(7)
ITEM NO	SMR CODE	NSN	CAGEC	PART NUMBER	DESCRIPTION AND USABLE ON CODES(UCO)	QTY
GROUP 0309 FUEL FILTERS						
FIG. 19 FUEL FILTER ASSEMBLY/WATER SEPARATOR AND MOUNTING HARDWARE						
1	PAOZZ	4330011891007	34623	12339198	FILTER-SEPARATOR,LI.....	1
2	PAOZZ	5305011904073	53964	SA609010	.SCREW,MACHINE.....	1
3	PAOZZ	5306011904553	53964	A609015	.BOLT,MACHINE 1/4-20 UNC-2A X .75	3
4	PAOZZ	5310008094058	53964	A609014	PART OF KIT P/N A630003.....	3
5	XAOZZ		99587	SC300079	.WASHER,FLAT 1/4 PART OF KIT P/N A630003.....	1
6	PAOZZ	4330011890889	34623	5579861	.HEAD.....	1
7	KBOZZ		53964	SC220072	.FILTER-SEPARATOR,LI.....	1
8	PAOZZ	5331013357592	53964	A618017	.FILTER ELEMENT,FLUI PART OF KIT P/N A910044.....	1
9	XAOZZ		53964	SC300081	.O-RING PART OF KIT P/N A910044.....	1
10	PAOZZ	4820014312499	19207	12446751	.SHELL ASSEMBLY.....	1
11	PAOZZ	4730011188278	76599	MMF4-SS	COCK,DRAIN.....	1
12	MOOZZ		34623	5588767	CLAMP,HOSE.....	3
13	PAOZZ	5340009848540	96906	MS21333-102	HOSE MAKE FROM HOSE P/N,9438257,26 INCHES LONG.....	1
14	PAOZZ	5310001249265	72582	271169	CLAMP,LOOP.....	2
15	PAOZZ	4730011865994	19207	12339888	NUT,PLAIN,ASSEMBLED #10-32.....	1
16	PAOZZ	5305000680502	96906	MS90725-6	ADAPTER,STRAIGHT,PI.....	2
17	PFOZZ	5340011868768	19207	12338563	SCREW,CAP,HEXAGON H 1/4-20 X 3/4...	1
18	PAOZZ	5310010666759	72962	21NE-040	BRACKET,PIPE.....	1
19	PAOZZ	5310004079566	96906	MS35338-45	NUT,SELF-LOCKING,HE 1/4-20.....	1
20	PAOZZ	5306002264825	80204	B1821BH031C075N	WASHER,LOCK 5/16.....	2
21	PAOZZ	4730000243971	81646	62606	BOLT,MACHINE 5/16-18 X 3/4.....	2
22	PAOZZ	4730011859453	19207	12339889	CLAMP,HOSE.....	1
23	PAOZZ	4820014560172	19207	12342953-2	ADAPTER,STRAIGHT,PI.....	1
					VALVE,CHECK.....	1

END OF FIGURE



*Figure 20. Glow Plug.*

SECTION II			TM9-2320-280-24P			
(1)	(2)	(3)	(4)	(5)	(6)	(7)
ITEM	SMR			PART		
NO	CODE	NSN	CAGEC	NUMBER	DESCRIPTION AND USABLE ON CODES(UC)	QTY
					GROUP 0311 ENGINE STARTING AIDS	
					FIG. 20 GLOW PLUG	
1	PAOZZ	2920011883863	70040	5614017	GLOW PLUG.....	8
END OF FIGURE						



SECTION II			TM9-2320-280-24P			
(1)	(2)	(3)	(4)	(5)	(6)	(7)
ITEM	SMR			PART		
NO	CODE	NSN	CAGEC	NUMBER	DESCRIPTION AND USABLE ON CODES(UOC)	QTY
GROUP 0312 ACCELERATOR, THROTTLE OR CHOKE CONTROLS						
FIG. 21 ACCELERATOR CONTROLS AND HAND THROTTLE						
1	PAOZZ	5310000614650	96906	MS51943-31	NUT, SELF-LOCKING, HE 1/4-20.....	5
2	PAOZZ	5310008238804	96906	MS27183-9	WASHER, FLAT 1/4.....	6
3	PFOZZ	5340013830462	19207	12338362	BRACKET, ANGLE LOWER.....	1
4	PAOZZ	5305000680502	96906	MS90725-6	SCREW, CAP, HEXAGON H 1/4-20 X 3/4...	1
5	PAOZZ	5340012972800	34623	5594101-C	BRACKET, ANGLE UPPER.....	1
6	PAOOO	2590012795714	60602	35752	CONTROL ASSEMBLY, PU.....	1
7	XAOZZ		60602	60018	.PACKING PREFORMED.....	1
8	XAOZZ		60602	30071	.NUT, HEXAGON 5/8-18.....	1
9	PAOZZ	5340012908360	60602	49005-1224	.HANDLE, MANUAL CONTR.....	1
10	PAOZZ	5305012908206	60602	30073	.SETSCREW.....	1
11	XAOZZ		60602	35752-12	.CABLE.....	1
12	XAOZZ		60602	10618	.WASHER, FLAT.....	1
13	PAOZZ	5315012849812	60602	10166	.PIN, LOCK.....	1
14	PAOZZ	5340011896748	34623	5569460	CLIP, SPRING TENSION.....	1
15	PAOZZ	2590011995423	60602	35745-44	CONTROL ASSEMBLY, PU.....	1
16	PAOZZ	5340000797837	96906	MS21333-67	CLAMP, LOOP.....	1
17	PAOZZ	5305002253843	80204	B1821BH025C100N	SCREW, CAP, HEXAGON H 1/4-20 X 1.00..	4
18	PAOZZ	5310008094058	96906	MS27183-10	WASHER, FLAT 1/4.....	1
19	PAOZZ	5315008392325	96152	A82-1	PIN, COTTER 1/16 X 1/2.....	1
20	PFOOO	2540012172669	34623	12338369	PEDAL ASSEMBLY, CONT.....	1
21	PBOZZ	2540014397308	34623	12460224	.PEDAL, CONTROL.....	1
22	PAOZZ	3110011899980	34623	5578635	.PLATE, RETAINING, BEA.....	2
23	PAOZZ	3120011867714	19207	12338356	.BEARING, SLEEVE.....	2
24	PAOZZ	5330011850587	34623	5578660-B	.GASKET.....	1
25	PAOZZ	5360011863737	34623	5578742	.SPRING, HELICAL, TORS.....	1
26	PAOZZ	2540011859656	19207	12338365	.PEDAL, CONTROL.....	1
27	PAOZZ	5315011857421	34623	5578764	.PIN, STRAIGHT, HEADED 3/16 X 1.25...	1
28	PAOZZ	5310008238804	96906	MS27183-9	.WASHER, FLAT 1/4.....	1
29	PAOZZ	5315008392325	96152	A82-1	.PIN, COTTER.....	1

END OF FIGURE

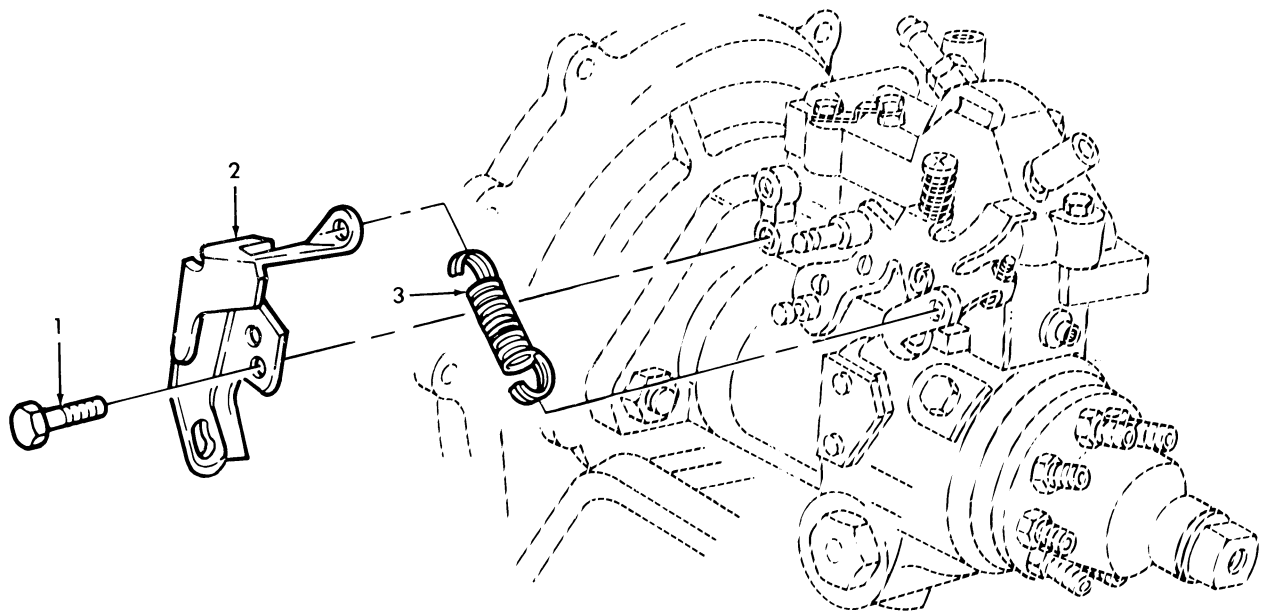

*Figure 22. Accelerator Cable Bracket and Idle Spring.*



SECTION II			TM9-2320-280-24P			
(1)	(2)	(3)	(4)	(5)	(6)	(7)
ITEM	SMR			PART		
NO	CODE	NSN	CAGEC	NUMBER	DESCRIPTION AND USABLE ON CODES(UC)	QTY
					GROUP 0312 ACCELERATOR, THROTTLE OR CHOKE CONTROLS	
					FIG. 22 ACCELERATOR CABLE BRACKET AND IDLE SPRING	
1	PAFZZ	5306011524693	24617	11504986	BOLT, MACHINE 8-1.25 X 14MM.....	2
2	PFFZZ	5340011821074	19207	12339142	BRACKET, MOUNTING.....	1
3	PAOZZ	5360012102852	19207	12339492	SPRING, HELICAL, EXTE.....	1

END OF FIGURE

**USE WITH BASIC AND A1 VEHICLES**

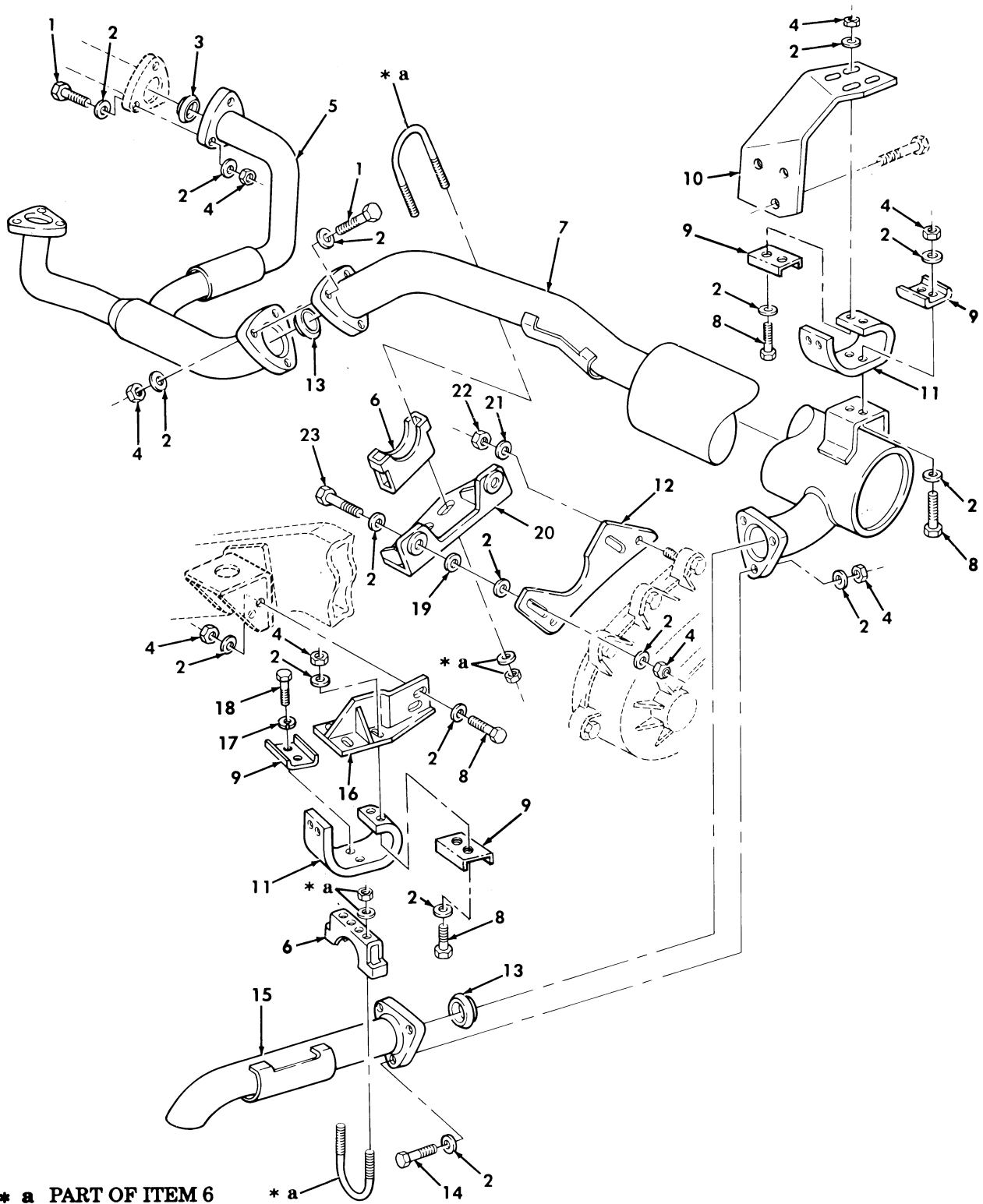

**\* a PART OF ITEM 6**

**\* FOR DEEP WATER FORDING  
REFER TO GROUP 3305**

*Figure 23. Muffer, Exhaust Pipes, and Related Parts.*

SECTION II			TM9-2320-280-24P			
(1)	(2)	(3)	(4)	(5)	(6)	(7)
ITEM NO	SMR CODE	NSN	CAGEC	PART NUMBER	DESCRIPTION AND USABLE ON CODES(UOC)	QTY
GROUP 04 EXHAUST SYSTEM						
0401 MUFFLER AND PIPES						
FIG. 23 MUFFLER, EXHAUST PIPES, AND RELATED PARTS						
1	PAOZZ	5305002693217	96906	MS90725-67	SCREW, CAP, HEXAGON H 3/8-16 X 2.25.. UOC:AVY, A11, A13, A14, A15, A20, A24, A25, A26, A27, B16, B17, B18, HVY, H11, H13, H14, H15, H16, H17, H18, H20, H21, H24, H25, H26, H27, H28, MMM	9
2	PAOZZ	5310000806004	96906	MS27183-14	WASHER, FLAT 3/8..... UOC:AVY, A11, A13, A14, A15, A20, A24, A25, A26, A27, B16, B17, B18, HVY, H11, H13, H14, H15, H16, H17, H18, H20, H21, H24, H25, H26, H27, H28, MMM	50
3	PAOZZ	5330011899738	19207	12338342	SEAL ASSY, MANIFOLD..... UOC:AVY, A11, A13, A14, A15, A20, A24, A25, A26, A27, B16, B17, B18, HVY, H11, H13, H14, H15, H16, H17, H18, H20, H21, H24, H25, H26, H27, H28, MMM	2
4	PAOZZ	5310009359021	96906	MS51943-35	NUT, SELF-LOCKING, HE 3/8-16..... UOC:AVY, A11, A13, A14, A15, A20, A24, A25, A26, A27, B16, B17, B18, HVY, H11, H13, H14, H15, H16, H17, H18, H20, H21, H24, H25, H26, H27, H28, MMM	28
5	PAOZZ	2990011877168	19207	12338351	PIPE, EXHAUST..... UOC:AVY, A11, A13, A14, A15, A20, A24, A25, A26, A27, B16, B17, B18, HVY, H11, H13, H14, H15, H16, H17, H18, H20, H21, H24, H25, H26, H27, H28, MMM	1
6	PAOZZ	5340012123553	19207	12338343-1	CLAMP, LOOP..... UOC:AVY, A11, A13, A14, A15, A20, A24, A25, A26, A27, B16, B17, B18, HVY, H11, H13, H14, H15, H16, H17, H18, H20, H21, H24, H25, H26, H27, H28, MMM	2
7	PAOZZ	2990011883281	76700	23244A	MUFFLER, EXHAUST..... UOC:AVY, A11, A13, A14, A15, A20, A24, A25, A26, A27, B16, B17, B18, HVY, H11, H13, H14, H15, H16, H17, H18, H20, H21, H24, H25, H26, H27, H28, MMM	1
8	PAOZZ	5305005432419	80204	B1821BH038C113N	SCREW, CAP, HEXAGON H 3/8-16 X 1.125.. UOC:AVY, A11, A13, A14, A15, A20, A24, A25, A26, A27, B16, B17, B18, HVY, H11, H13, H14, H15, H16, H17, H18, H20, H21, H24, H25, H26, H27, H28, MMM	10
9	PAOZZ	5340012124887	34623	5588675	STRAP, RETAINING..... UOC:AVY, A11, A13, A14, A15, A20, A24, A25, A26, A27, B16, B17, B18, HVY, H11, H13, H14, H15, H16, H17, H18, H20, H21, H24, H25, H26, H27, H28, MMM	6
10	PAOZZ	2990011877030	19207	12338221	HANGER, ENGINE EXHAU..... UOC:AVY, A11, A13, A14, A15, A20, A24, A25,	1

SECTION II			TM9-2320-280-24P			
(1)	(2)	(3)	(4)	(5)	(6)	(7)
ITEM	SMR			PART		
NO	CODE	NSN	CAGEC	NUMBER	DESCRIPTION AND USABLE ON CODES(UOC)	QTY
11	PAOZZ	2540013094459	34623	5588778	A26,A27,B16,B17,B18,HVY,H11,H13,H14, H15,H16,H17,H18,H20,H21,H24,H25,H26, H27,H28,MMM INSULATION,THERMAL,.....	2
12	PFOZZ	5340012114025	34623	5590387	UOC:AVY,A11,A13,A14,A15,A20,A24,A25, A26,A27,B16,B17,B18,HVY,H11,H13,H14, H15,H16,H17,H18,H20,H21,H24,H25,H26, H27,H28,MMM STRAP,RETAINING.....	1
13	PAOZZ	5330012000466	19207	12338339	UOC:AVY,A11,A13,A14,A15,A20,A24,A25, A26,A27,B16,B17,B18,HVY,H11,H13,H14, H15,H16,H17,H18,H20,H21,H24,H25,H26, H27,H28,MMM GASKET.....	2
14	PAOZZ	5305007829489	80204	B1821BH038C200N	UOC:AVY,A11,A13,A14,A15,A20,A24,A25, A26,A27,B16,B17,B18,HVY,H11,H13,H14, H15,H16,H17,H18,H20,H21,H24,H25,H26, H27,H28,MMM SCREW,CAP,HEXAGON H 3/8-16 X 2.00..	3
15	PAOZZ	2990011901089	19207	12338350	UOC:AVY,A11,A13,A14,A15,A20,A24,A25, A26,A27,B16,B17,B18,HVY,H11,H13,H14, H15,H16,H17,H18,H20,H21,H24,H25,H26, H27,H28,MMM PIPE,EXHAUST.....	1
16	PFOZZ	2990012118587	19207	12338346	UOC:AVY,A11,A13,A14,A15,A20,A24,A25, A26,A27,B16,B17,B18,HVY,H11,H13,H14, H15,H16,H17,H18,H20,H21,H24,H25,H26, H27,H28,MMM HANGER,ENGINE EXHAU.....	1
17	PAOZZ	5310006379541	96906	MS35338-46	UOC:AVY,A11,A13,A14,A15,A20,A24,A25, A26,A27,B16,B17,B18,HVY,H11,H13,H14, H15,H16,H17,H18,H20,H21,H24,H25,H26, H27,H28,MMM WASHER,LOCK 3/8.....	2
18	PAOZZ	5305000680510	80204	B1821BH038C100N	UOC:AVY,A11,A13,A14,A15,A20,A24,A25, A26,A27,B16,B17,B18,HVY,H11,H13,H14, H15,H16,H17,H18,H20,H21,H24,H25,H26, H27,H28,MMM SCREW,CAP,HEXAGON H 3/8-16 X 1.00..	2
19	PAOZZ	5325011871604	19207	12338338	UOC:AVY,A11,A13,A14,A15,A20,A24,A25, A26,A27,B16,B17,B18,HVY,H11,H13,H14, H15,H16,H17,H18,H20,H21,H24,H25,H26, H27,H28,MMM GROMMET,NONMETALLIC.....	2
20	PFOZZ	5340012113137	34623	12338340	UOC:AVY,A11,A13,A14,A15,A20,A24,A25, A26,A27,B16,B17,B18,HVY,H11,H13,H14, H15,H16,H17,H18,H20,H21,H24,H25,H26, H27,H28,MMM BRACKET,ANGLE.....	1

SECTION II			TM9-2320-280-24P			
(1)	(2)	(3)	(4)	(5)	(6)	(7)
ITEM NO	SMR CODE	NSN	CAGEC	PART NUMBER	DESCRIPTION AND USABLE ON CODES(UC)	QTY
21	PAOZZ	5310014124013	24617	2436163	WASHER,FLAT #10..... UOC:AVY,A11,A13,A14,A15,A20,A24,A25, A26,A27,B16,B17,B18,HVY,H11,H13,H14, H15,H16,H17,H18,H20,H21,H24,H25,H26, H27,H28,MMM	2
22	PAOZZ	5310011430512	73342	29520052	NUT #10-15..... UOC:AVY,A11,A13,A14,A15,A20,A24,A25, A26,A27,B16,B17,B18,HVY,H11,H13,H14, H15,H16,H17,H18,H20,H21,H24,H25,H26, H27,H28,MMM	2
23	PAOZZ	5305008213869	80204	B1821BH038C175N	SCREW,CAP,HEXAGON H 3/8-16 X 1.75.. UOC:AVY,A11,A13,A14,A15,A20,A24,A25, A26,A27,B16,B17,B18,HVY,H11,H13,H14, H15,H16,H17,H18,H20,H21,H24,H25,H26, H27,H28,MMM	2

END OF FIGURE

**USE WITH A2 VEHICLES**

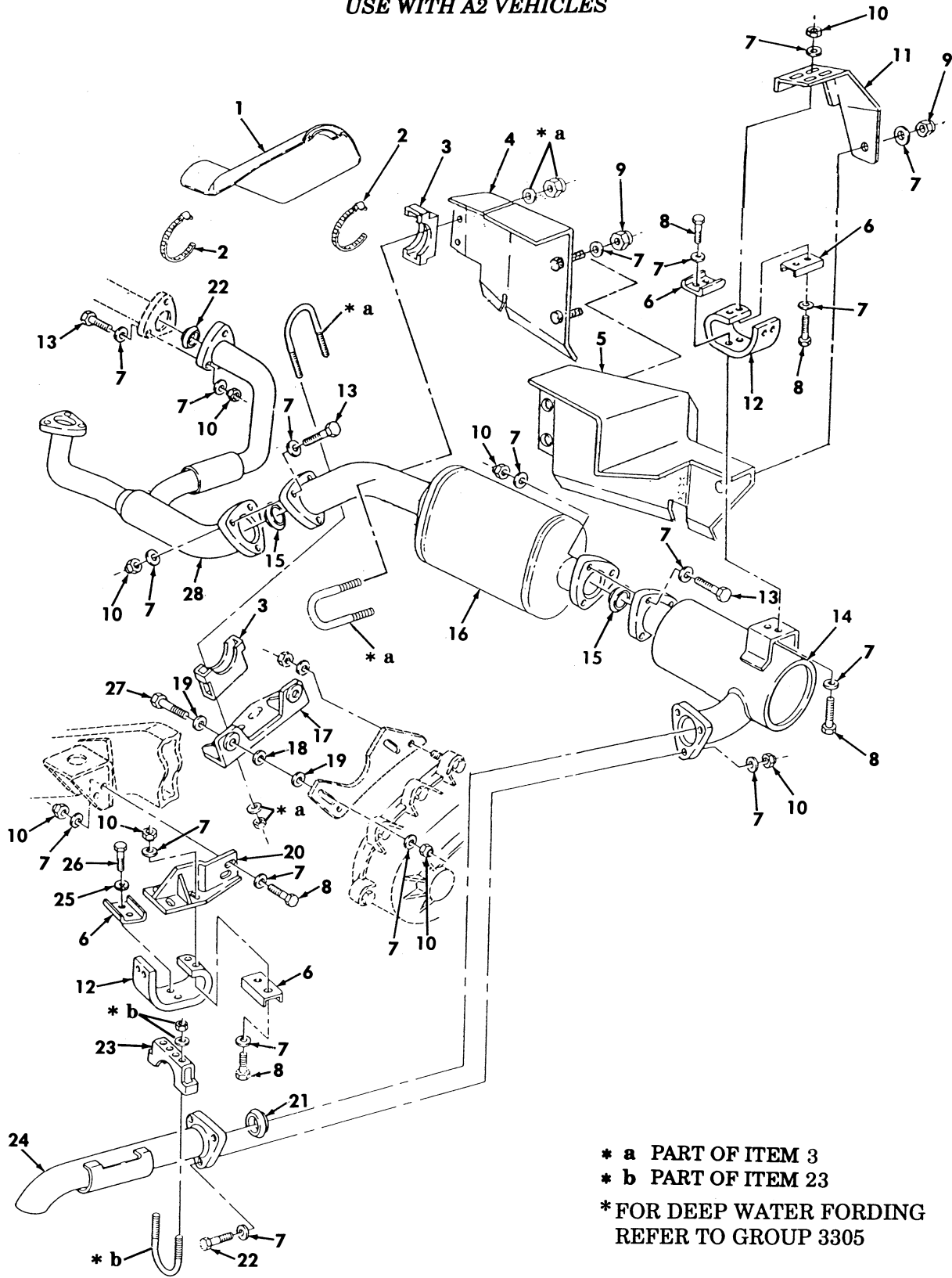

Figure 24. Muffer, Exhaust Pipes, and Related Parts.

SECTION II			TM9-2320-280-24P			
(1)	(2)	(3)	(4)	(5)	(6)	(7)
ITEM	SMR			PART		
NO	CODE	NSN	CAGEC	NUMBER	DESCRIPTION AND USABLE ON CODES(UOC)	QTY
GROUP 0401 MUFFLER AND PIPES						
FIG. 24 MUFFLER, EXHAUST PIPES, AND RELATED PARTS						
1	PAOZZ	2990014112728	34623	6003083	GUARD, MUFFLER-EXHAU.....	1
					UOC: BVY, B15, B20, B24, B25, C17, NNN	
2	PAOZZ	4730009086292	19207	11608950-13	CLAMP, HOSE 3.50-2.56.....	3
					UOC: BVY, B15, B20, B24, B25, C17, NNN	
3	PAOZZ		19207	12338343-2	CLAMP, LOOP.....	2
					UOC: BVY, B15, B20, B24, B25, C17, NNN	
4	PAOZZ	2540014141275	19207	12460082	INSULATION, THERMAL,.....	1
					UOC: BVY, B15, B20, B24, B25, C17, NNN	
5	PAOZZ	2990014113954	34623	12460081	GUARD, MUFFLER-EXHAU.....	1
					UOC: BVY, B15, B20, B24, B25, C17, NNN	
6	PAOZZ	5340012124887	34623	5588675	STRAP, RETAINING.....	6
					UOC: BVY, B15, B20, B24, B25, C17, NNN	
7	PAOZZ	5310000806004	96906	MS27183-14	WASHER, FLAT 3/8.....	54
					UOC: BVY, B15, B20, B24, B25, C17, NNN	
8	PAOZZ	5305000680511	80204	B1821BH038C125N	SCREW, CAP, HEXAGON H 3/8-16 X 1.25..	12
					UOC: BVY, B15, B20, B24, B25, C17, NNN	
9	PAOZZ	5310010128962	24617	9416918	NUT, PLAIN, EXTENDED.....	3
					UOC: BVY, B15, B20, B24, B25, C17, NNN	
10	PAOZZ	5310009359021	96906	MS51943-35	NUT, SELF-LOCKING, HE 3/8 X 16.....	31
					UOC: BVY, B15, B20, B24, B25, C17, NNN	
11	PAOZZ	5340014132689	19207	12460083	BRACKET, MOUNTING.....	1
					UOC: BVY, B15, B20, B24, B25, C17, NNN	
12	PAOZZ	2540013094459	34623	5588778	INSULATION, THERMAL,.....	2
					UOC: BVY, B15, B20, B24, B25, C17, NNN	
13	PAOZZ	5305002693217	96906	MS90725-67	SCREW, CAP, HEXAGON H 3/8-16 X 2.25..	12
					UOC: BVY, B15, B20, B24, B25, C17, NNN	
14	PAOZZ	2990014113947	34623	12460090	MUFFLER, EXHAUST.....	1
					UOC: BVY, B15, B20, B24, B25, C17, NNN	
15	PAOZZ	5330011899738	19207	12338342	SEAL ASSY, MANIFOLD.....	2
					UOC: BVY, B15, B20, B24, B25, C17, NNN	
16	PAOZA	2990014120142	19207	12460091	CONVERTER, CATALYTIC.....	1
					UOC: BVY, B15, B20, B24, B25, C17, NNN	
17	PAOZZ	5340012113137	34623	12338340	BRACKET, ANGLE.....	1
					UOC: BVY, B15, B20, B24, B25, C17, NNN	
18	PAOZZ	5325011871604	19207	12338338	GROMMET, NONMETALLIC.....	2
					UOC: BVY, B15, B20, B24, B25, C17, NNN	
19	PAOZZ	5310012113811	7X677	9417793	WASHER, FLAT.....	4
					UOC: BVY, B15, B20, B24, B25, C17, NNN	
20	PFOZZ	2990012118587	19207	12338346	HANGER, ENGINE EXHAU.....	1
					UOC: BVY, B15, B20, B24, B25, C17, NNN	
21	PAOZZ	5330012000466	19207	12338339	GASKET.....	3
					UOC: BVY, B15, B20, B24, B25, C17, NNN	
22	PAOZZ	5305007829489	80204	B1821BH038C200N	SCREW, CAP, HEXAGON H.....	3
					UOC: BVY, B15, B20, B24, B25, C17, NNN	
23	PAOZZ	5340012123553	19207	12338343-1	CLAMP, LOOP.....	1
					UOC: BVY, B15, B20, B24, B25, C17, NNN	
24	PAOZZ	2990011901089	34623	12338350	PIPE, EXHAUST.....	1
					UOC: BVY, B15, B20, B24, B25, C17, NNN	

SECTION II		TM9-2320-280-24P					
(1)	(2)	(3)	(4)	(5)	(6)	(7)	
ITEM	SMR			PART			
NO	CODE	NSN	CAGEC	NUMBER	DESCRIPTION AND USABLE ON CODES(UC)	QTY	
25	PAOZZ	5310006379541	96906	MS35338-46	WASHER, LOCK.....	2	
					UC:BVY, B15, B20, B24, B25, C17, NNN		
26	PAOZZ	5305000680510	80204	B1821BH038C100N	SCREW, CAP, HEXAGON H 3/8-16 X 1.00..	2	
					UC:BVY, B15, B20, B24, B25, C17, NNN		
27	PAOZZ	5305008213869	80204	B1821BH038C175N	SCREW, CAP, HEXAGON H 3/8-16 X 1.75..	2	
					UC:BVY, B15, B20, B24, B25, C17, NNN		
28	PAOZZ	2990014144072	34623	12460086	PIPE, EXHAUST.....	1	
					UC:BVY, B15, B20, B24, B25, C17, NNN		

END OF FIGURE



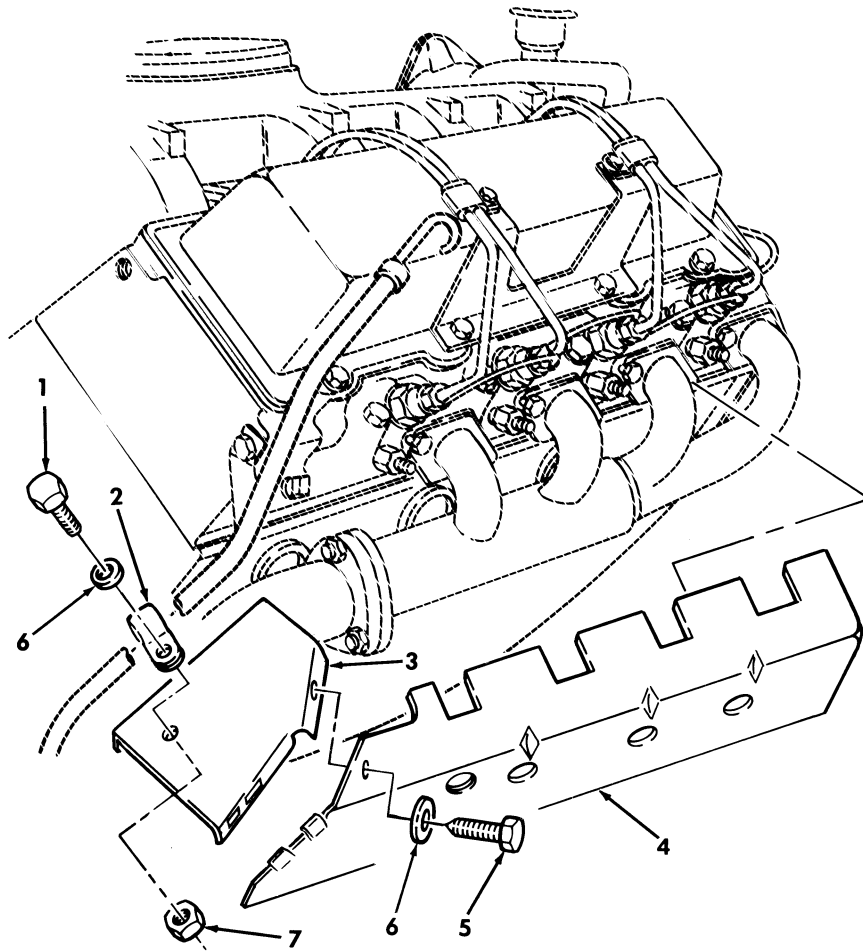

Figure 25. Exhaust Manifold Heat Shield.

SECTION II			TM9-2320-280-24P			
(1)	(2)	(3)	(4)	(5)	(6)	(7)
ITEM	SMR			PART		
NO	CODE	NSN	CAGEC	NUMBER	DESCRIPTION AND USABLE ON CODES(UOC)	QTY
GROUP 0401 MUFFLER AND PIPES						
FIG. 25 EXHAUST MANIFOLD HEAT SHIELD						
1	PAOZZ	5305000712506	80204	B1821BH025C050N	SCREW,CAP,HEXAGON H 1/4-20 X 1/2...	1
2	PAOZZ	5340011661672	24617	120528	CLAMP,LOOP.....	1
3	PFOZZ	2990012106982	19207	12339181	GUARD,MUFFLER-EXHAU R.H.....	1
4	PFOZZ	2990012100427	19207	12339174	GUARD,MUFFLER-EXHAU L.H.....	1
5	PAOZZ	5305012046502	78189	112-1008800-003	SCREW #10-32 X 1/2.....	1
6	PAOZZ	5310012113811	7X677	9417793	WASHER,FLAT.....	2
7	PAOZZ	5310000614650	96906	MS51943-31	NUT,SELF-LOCKING,HE 1/4-20.....	1

END OF FIGURE

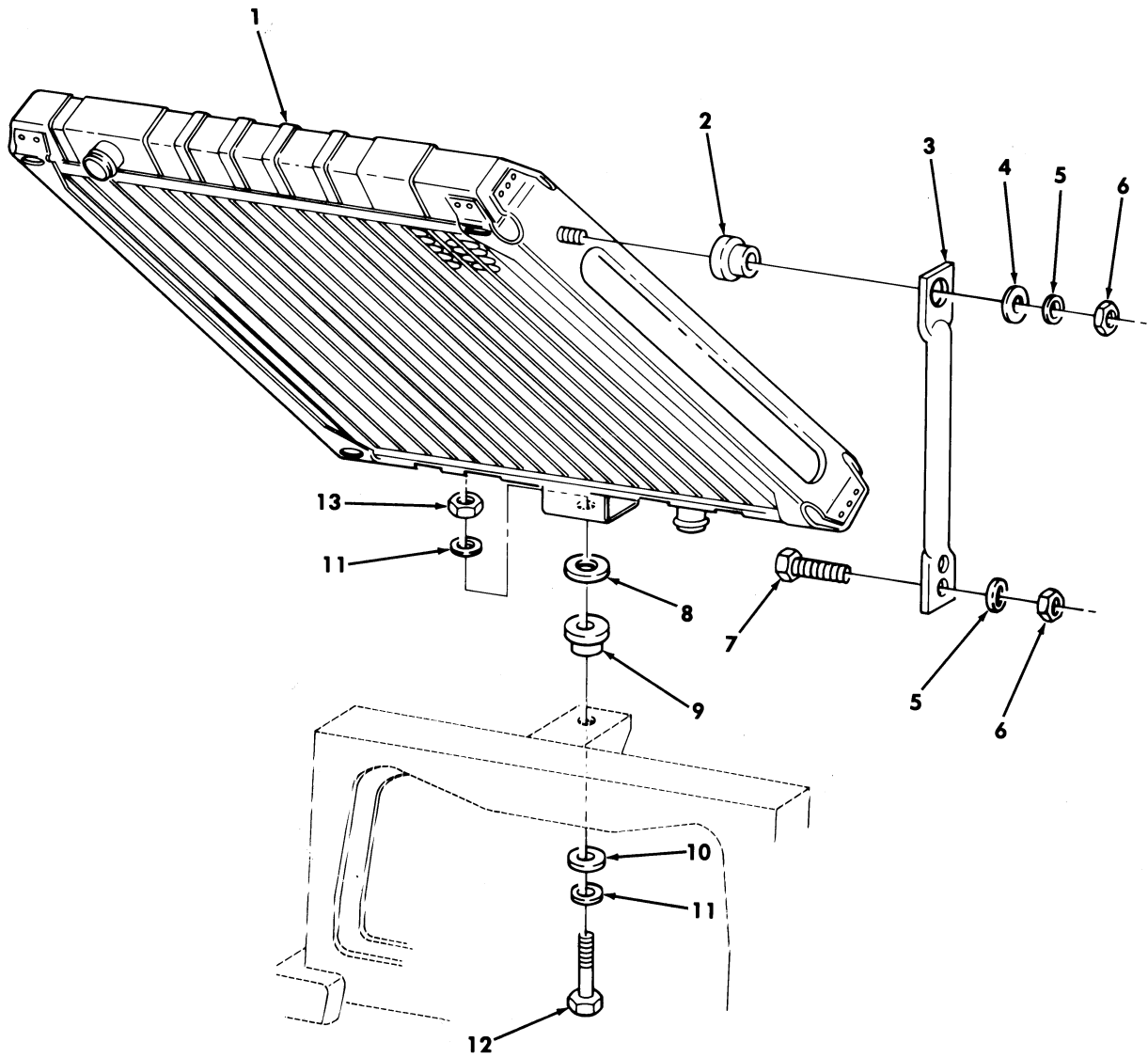

Figure 26. Radiator and Mounting Hardware.

SECTION II			TM9-2320-280-24P			
(1)	(2)	(3)	(4)	(5)	(6)	(7)
ITEM NO	SMR CODE	NSN	CAGEC	PART NUMBER	DESCRIPTION AND USABLE ON CODES(UOC)	QTY
GROUP 05 COOLING SYSTEM						
0501 RADIATOR, EVAPORATIVE COOLER OR HEAT EXCHANGE						
FIG. 26 RADIATOR AND MOUNTING HARDWARE						
1	PAOFH	2930014059885	19207	12446985	RADIATOR, ENGINE COO.....	1
2	PAOZZ	5325011871604	10177	M-200-60-EP	GROMMET, NONMETALLIC.....	2
3	PFOZZ	2930012106940	19207	12339165-1	RETAINER, RADIATOR L.H.....	1
3	PFOZZ	2930012188103	19207	12339165-2	RETAINER, RADIATOR R.H.....	1
4	PAOZZ	5310012581536	OMAY0	5593221	WASHER, FLAT 3/8.....	2
5	PAOZZ	5310012057923	34623	5593213	WASHER, FLAT 3/8.....	6
6	PAOZZ	5310009359021	96906	MS51943-35	NUT, SELF-LOCKING, HE 3/8-16.....	6
7	PAOZZ	5305012510756	34623	5593328	SCREW, CAP, HEXAGON H 3/8-16 X 1.00..	4
8	PAOZZ	5310012690786	19207	12340263	WASHER, FLAT 1/2.....	1
9	PAOZZ	5340011973461	19207	12340264	MOUNT, RESILIENT LOWER.....	1
10	PAOZZ	5310012507835	7X677	9428851	WASHER, FLAT 1/2.....	1
11	PAOZZ	5310011211703	24617	2436165	WASHER, FLAT 1/2.....	2
12	PAOZZ	5305000712071	80204	B1821BH050C200N	SCREW, CAP, HEXAGON H 1/2-13 X 2.00..	1
13	PAOZZ	5310011494407	24617	9442900	NUT, SELF-LOCKING, HE 1/2-13.....	1

END OF FIGURE

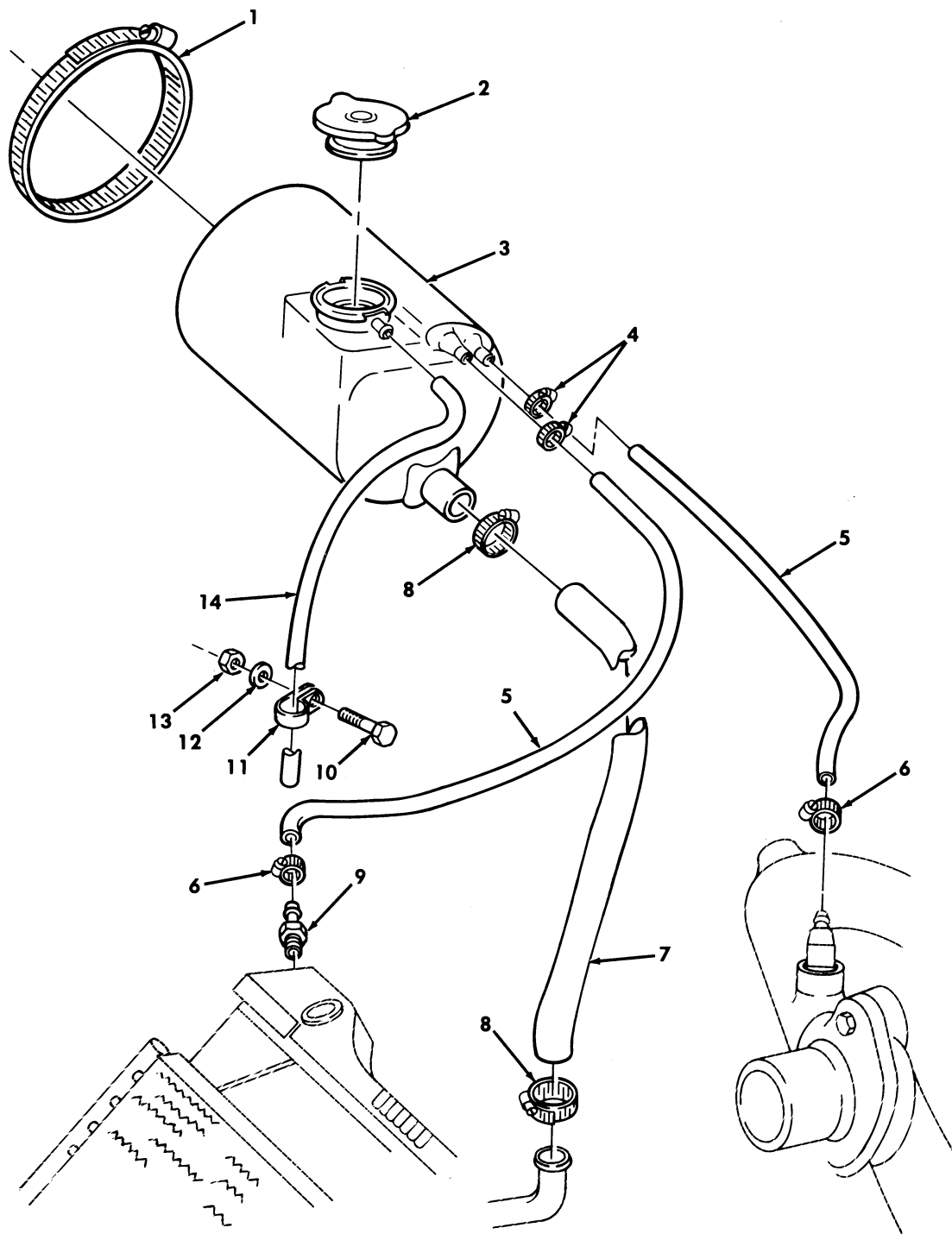

Figure 27. Surge Tank and Related Parts.

SECTION II			TM9-2320-280-24P			
(1)	(2)	(3)	(4)	(5)	(6)	(7)
ITEM NO	SMR CODE	NSN	CAGEC	PART NUMBER	DESCRIPTION AND USABLE ON CODES(UC)	QTY
					GROUP 0501 RADIATOR, EVAPORATIVE COOLER OR HEAT EXCHANGER	
					FIG. 27 SURGE TANK AND RELATED PARTS	
1	PAOZZ	4730009086294	76599	96HSS	CLAMP, HOSE.....	2
2	PAOZZ	2930014267711	78225	R17	CAP, FILLER OPENING 15 PSI.....	1
3	PAOZZ	2930012565350	19207	12340061	TANK, RADIATOR, OVERF.....	1
4	PAOZZ	4730011188278	76599	MMF4-SS	CLAMP, HOSE.....	4
5	PAOZZ	4720011866018	19207	12339155-1	HOSE, NONMETALLIC.....	2
6	PAOZZ	4730014138244	34623	11608950-1	CLAMP, HOSE.....	1
7	PAOZZ	4720013602380	19207	12340046	HOSE, NONMETALLIC.....	1
8	PAOZZ	4730005868463	76599	16HSS	CLAMP, HOSE.....	2
9	PAOZZ	4730011859453	34623	12339889	ADAPTER, STRAIGHT, PI.....	1
10	PAOZZ	5305000680508	80204	B1821BH025C075N	SCREW, CAP, HEXAGON H 1/4-20 X 3/4...	1
11	PAOZZ	5340003858820	75272	COV-0909	CLAMP, LOOP.....	1
12	PAOZZ	5310011023270	24617	2436161	WASHER, FLAT 1/4.....	1
13	PAOZZ	5310000614650	96906	MS51943-31	NUT, SELF-LOCKING, HE 1/4-20.....	1
14	MOOZZ		34623	5578999	HOSE MAKE FROM HOSE, P/N ET029, 18 INCHES LONG.....	1

END OF FIGURE

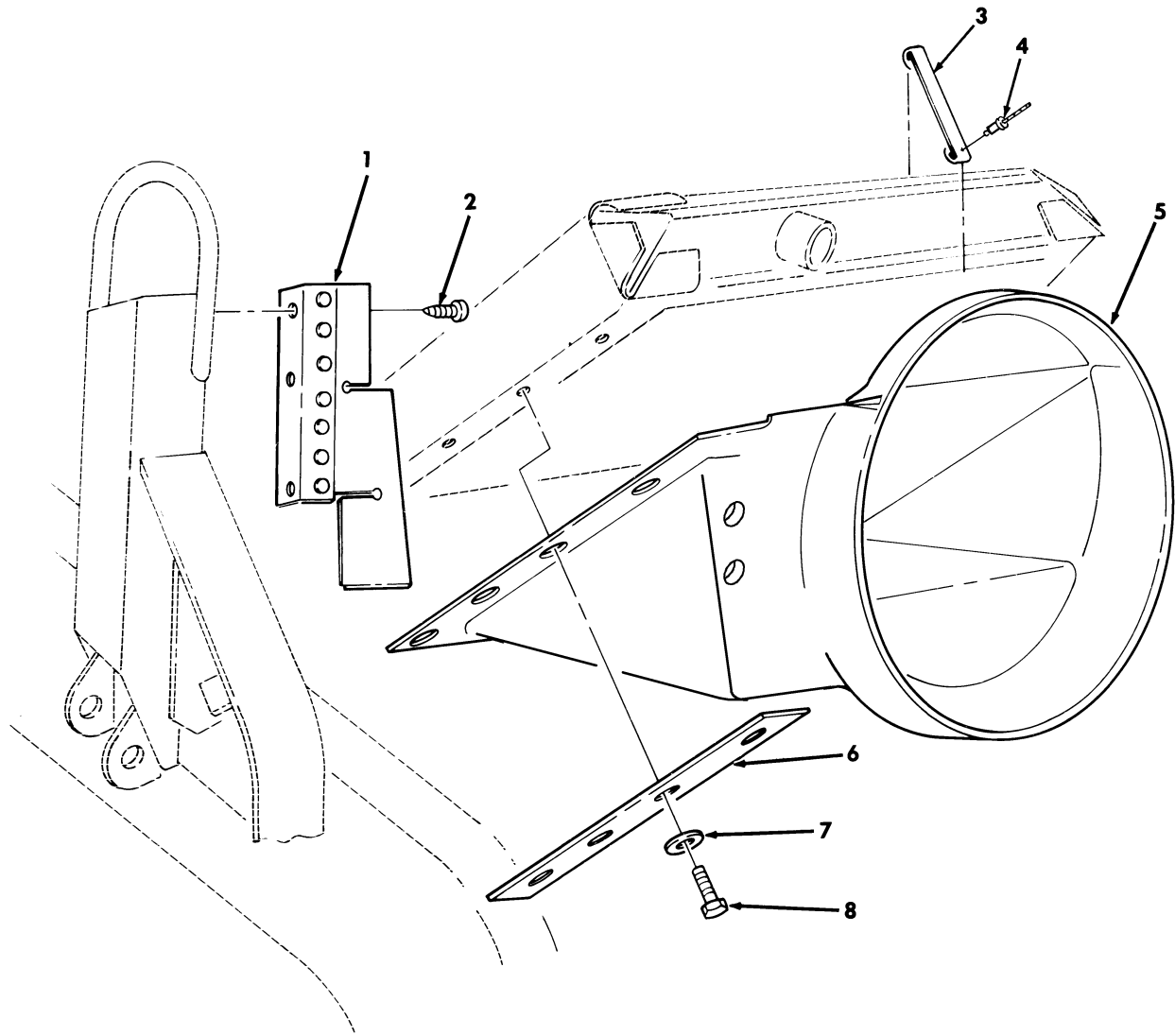

Figure 28. Radiator Shroud and Related Parts.

SECTION II			TM9-2320-280-24P			
(1)	(2)	(3)	(4)	(5)	(6)	(7)
ITEM NO	SMR CODE	NSN	CAGEC	PART NUMBER	DESCRIPTION AND USABLE ON CODES(UC)	QTY
					GROUP 0502 COWLING,DEFLECTOR,AIR DUCTS,SHROUDS	
					FIG. 28 RADIATOR SHROUD AND RELATED PARTS	
1	PAOZZ	2510012106939	19207	12339166-1	SHIELD ASSEMBLY,SHR L.H.....	1
1	PAOZZ	2990012104276	19207	12339166-2	SHIELD ASSEMBLY,SHR R.H.....	1
2	PAOZZ	5305000526921	80205	MS24629-57	SCREW,TAPPING 1/4-20 X 1/2.....	6
3	PAOZZ	5340012510724	19207	12339154-1	STRAP,RETAINING RADIATOR.....	1
4	PAOZZ	5320010232529	81349	M24243/1A404	RIVET,BLIND 1/8 DIA..126-.187 GRIP.	1
5	PAOOO	2930013175358	34623	5935356	SHROUD,FAN,RADIATOR.....	1
					UOC:AVY,A11,A13,A14,A15,A20,A24,A25,A26,A27,B16,B17,B18,HVY,H11,H13,H14,H15,H16,H17,H18,H20,H21,H24,H25,H26,H27,H28,MMM	
5	PAOOO	2930014710622	34623	12342435-1	SHROUD,FAN,RADIATOR.....	1
					UOC:BVY,B15,B20,B24,B25,C17,NNN	
6	PFOZZ	5340012123709	34623	5591252	STRAP,RETAINING.....	2
7	PAOZZ	5310005825965	96906	MS35338-44	WASHER,LOCK 1/4.....	8
8	PAOZZ	5305000712506	80204	B1821BH025C050N	SCREW,CAP,HEXAGON H 1/4-20 X 1/2...	8
					UOC:AVY,A11,A13,A14,A15,A20,A24,A25,A26,A27,B16,B17,B18,HVY,H11,H13,H14,H15,H16,H17,H18,H20,H21,H24,H25,H26,H27,H28,MMM	
8	PAOZZ	5305000687837	80204	B1821BH025C063N	SCREW,CAP,HEXAGON H 1/4-20 X 5/8...	8
					UOC:BVY,B15,B20,B24,B25,C17,NNN	

END OF FIGURE



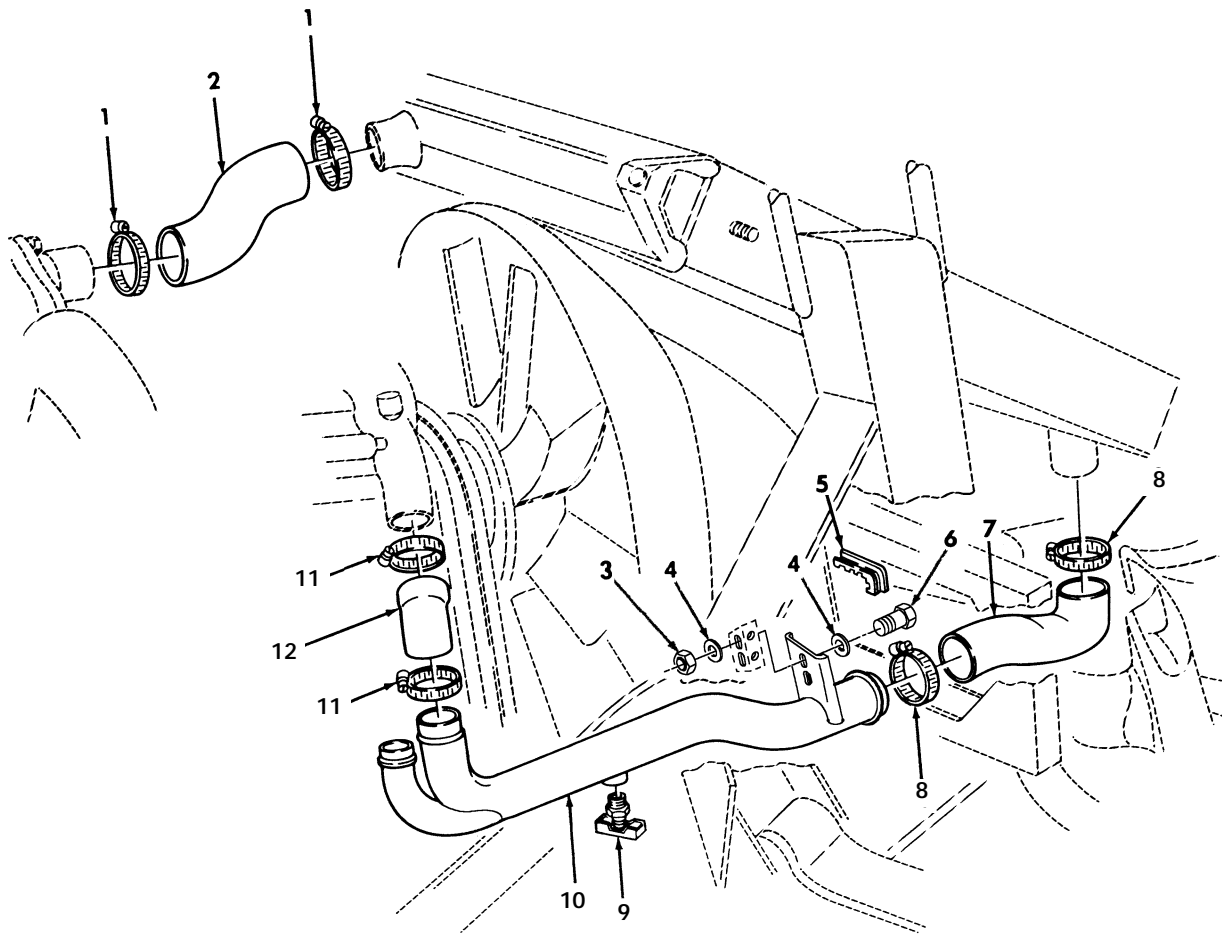

Figure 29. Radiator Hoses and Related Parts.

SECTION II			TM9-2320-280-24P			
(1)	(2)	(3)	(4)	(5)	(6)	(7)
ITEM	SMR			PART		
NO	CODE	NSN	CAGEC	NUMBER	DESCRIPTION AND USABLE ON CODES(UC)	QTY
					GROUP 0503 WATER MANIFOLD,HEADERS, THERMOSTATS AND HOUSING GASKETS	
					FIG. 29 RADIATOR HOSES ANS RELATED PARTS	
1	PAOZZ	4730002043491	66295	C32P	CLAMP,HOSE.....	2
2	PAOZZ	4720011883909	19207	12339160	HOSE,PREFORMED INLET.....	1
3	PAOZZ	5310000614650	96906	MS51943-31	NUT,SELF-LOCKING,HE.....	2
4	PAOZZ	5310011023270	24617	2436161	WASHER,FLAT.....	4
5	MOOZZ		06968	42130156-7	PAD,CUSHIONING MAKE FROM PAD,P/N 12339902-1,5.6 INCHES LONG.....	2
6	PAOZZ	5305000680508	80204	B1821BH025C075N	SCREW,CAP,HEXAGON H.....	2
7	PAOZZ	4720011873386	19207	12339162	HOSE,PREFORMED LOWER.....	1
8	PAOZZ	4730009098627	76599	36HSS	CLAMP,HOSE.....	2
9	PAOZZ	4820007529040	93061	DC603-2	COCK,DRAIN.....	1
10	PAOZZ	4710011880028	34623	5578604	TUBE,BENT,METALLIC LOWER.....	1
11	PAOZZ	4730013299151	7Z588	CT250L	CLAMP,HOSE.....	2
12	PAOZZ	4720011881370	19207	12339159	HOSE,PREFORMED.....	1

END OF FIGURE

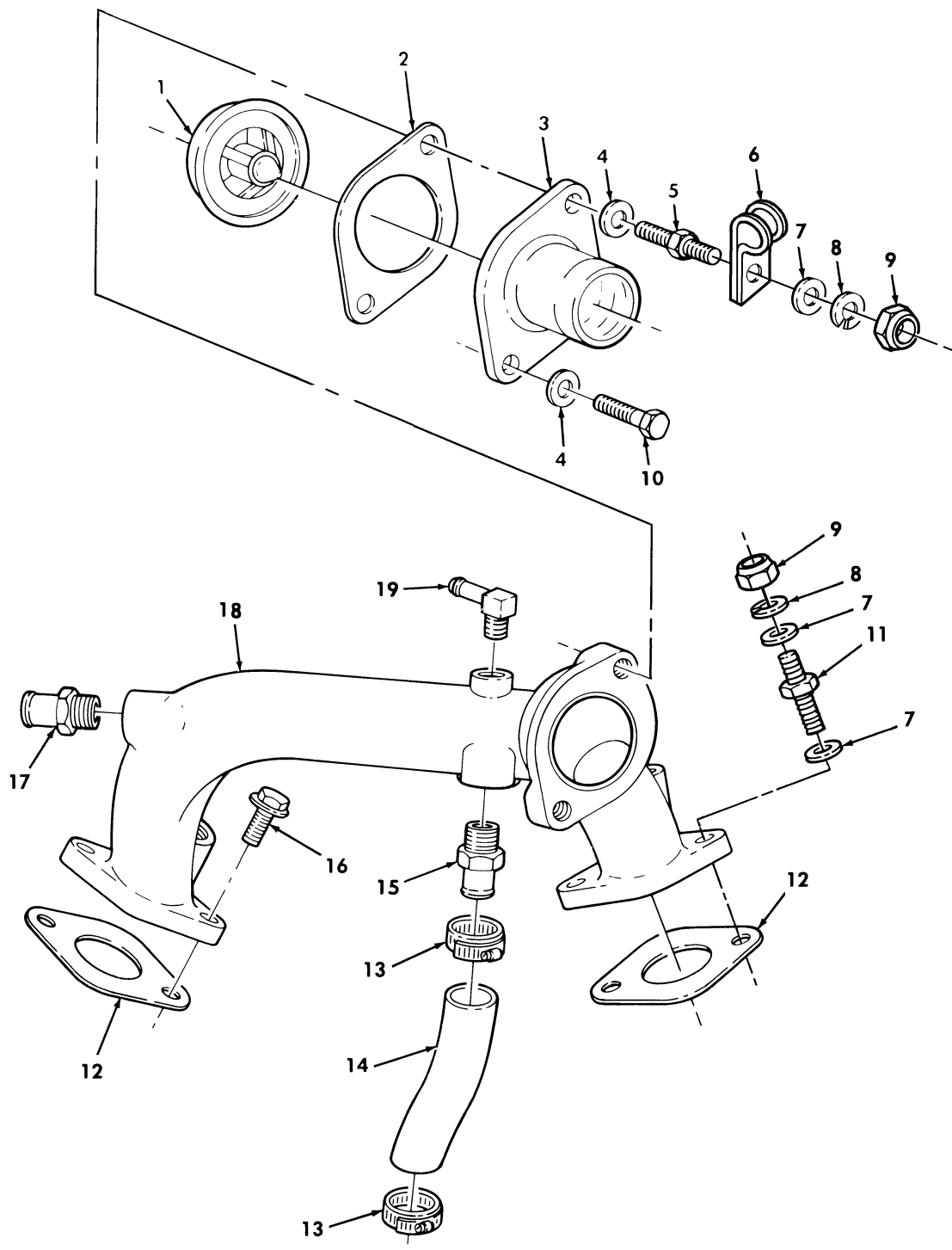

Figure 30. Thermostat, Water Crossover, and Attaching Hardware.

SECTION II			TM9-2320-280-24P			
(1)	(2)	(3)	(4)	(5)	(6)	(7)
ITEM NO	SMR CODE	NSN	CAGEC	PART NUMBER	DESCRIPTION AND USABLE ON CODES(UC)	QTY
					GROUP 0503 WATER MANIFOLD,HEADERS, THERMOSTAT AND HOUSING GASKETS	
					FIG. 30 THERMOSTAT,WATER CROSSOVER, AND ATTACHING HARDWARE	
1	PAOZZ	6620011468006	7X677	14077122	THERMOSTAT, FLOW CON 6.2 LITER..... UC:AVY,A11,A13,A14,A15,A20,A24,A25, A26,A27,B16,B17,B18,HVY,H11,H13,H14, H15,H16,H17,H18,H20,H21,H24,H25,H26, H27,H28,MMM	1
1	PAOZZ	6685014449478	7X677	12551497	THERMOSTAT, FLOW CON 6.5/6.5 DETUNED	1
2	PAOZZ	5330014348611	7X677	12551591	GASKET.....	1
3	PAOZZ	2930011474198	7X677	14028918	WATER OUTLET,ENGINE.....	1
4	PAOZZ	5310014124013	24617	2436163	WASHER, FLAT #10.....	2
5	PAOZZ	5307011501227	7X677	14033946	STUD, SHOULDERED 10-1.5 X 30 MM..... UC:AVY,A11,A13,A14,A15,A20,A24,A25, A26,A27,B16,B17,B18,HVY,H11,H13,H14, H15,H16,H17,H18,H20,H21,H24,H25,H26, H27,H28,MMM	1
5	PAOZZ	5307012919018	19207	12339406-2	STUD, SHOULDERED..... UC:BVY,B15,B20,B24,B25,C17,NNN	1
6	PAOZZ	5340001519651	96906	MS21333-129	CLAMP, LOOP.....	1
7	PAOZZ	5310012101587	7X677	11500256	WASHER, FLAT..... UC:BVY,B15,B20,B24,B25,C17,NNN	3
8	PAOZZ	5310012067306	7X677	11500207	WASHER, LOCK..... UC:BVY,B15,B20,B24,B25,C17,NNN	2
9	PAOZZ	5310013958747	80204	B18241B100F	NUT, PLAIN, HEXAGON 10-1.5 MM..... UC:BVY,B15,B20,B24,B25,C17,NNN	2
10	PAOZZ	5306011654283	24617	11500831	BOLT, SELF-LOCKING 10-1.5 X 35 MM...	1
11	PAOZZ	5307014655796	19207	12339406-4	STUD, SHOULDERED M10-1.5 X 30 X 20.. UC:BVY,B15,B20,B24,B25,C17,NNN	1
12	PAOZZ	5330011490874	7X677	10137488	GASKET.....	2
13	PAOZZ	4730014440701	7X677	11516230	CLAMP, HOSE 6.5 LITER..... UC:BVY,B15,B20,B24,B25,C17,NNN	2
13	PAOZZ	4730001669178	7X677	12337891	CLAMP, HOSE 6.2/6.5 DETUNED..... UC:AVY,A11,A13,A14,A15,A20,A24,A25, A26,A27,B16,B17,B18,HVY,H11,H13,H14, H15,H16,H17,H18,H20,H21,H24,H25,H26, H27,H28,MMM	2
14	MOOZZ		7X677	23500084	HOSE MAKE FROM HOSE, P/N 4377,5 INCHES LONG 6.2/6.5 DETUNED..... UC:AVY,A11,A13,A14,A15,A20,A24,A25, A26,A27,B16,B17,B18,HVY,H11,H13,H14, H15,H16,H17,H18,H20,H21,H24,H25,H26, H27,H28,MMM	1
14	MOOZZ		7X677	10243629	HOSE, NONMETALLIC 6.5 LITER, MAKE FROM HOSE, P/N MS521302B206R, 5-1/2 INCHES LONG..... UC:BVY,B15,B20,B24,B25,C17,NNN	1
15	PAOZZ	4730014452358	7X677	10183956	ADAPTER, STRAIGHT, PI 6.5 LITER..... UC:BVY,B15,B20,B24,B25,C17,NNN	1
15	PAOZZ	4730011826565	7X677	3739798	ADAPTER, STRAIGHT, PI 6.2/6.5 DETUNED	1

SECTION II			TM9-2320-280-24P			
(1)	(2)	(3)	(4)	(5)	(6)	(7)
ITEM NO	SMR CODE	NSN	CAGEC	PART NUMBER	DESCRIPTION AND USABLE ON CODES(UC)	QTY
16	PAOZZ	5306011496280	7X677	1635490	UOC:AVY,A11,A13,A14,A15,A20,A24,A25,A26,A27,B16,B17,B18,HVY,H11,H13,H14,H15,H16,H17,H18,H20,H21,H24,H25,H26,H27,H28,MMM BOLT,SELF-LOCKING.....	4
16	PAOZZ	5306011496280	7X677	1635490	UOC:AVY,A11,A13,A14,A15,A20,A24,A25,A26,A27,B16,B17,B18,HVY,H11,H13,H14,H15,H16,H17,H18,H20,H21,H24,H25,H26,H27,H28,MMM BOLT,SELF-LOCKING.....	3
17	PAOZZ	4730011482758	7X677	354501	UOC:BVY,B15,B20,B24,B25,C17,NNN ADAPTER,STRAIGHT,PI.....	1
18	PAOZZ	2930014607507	7X677	12554091	WATER OUTLET,ENGINE 6.5/6.5 DETUNED	1
18	PAOZZ	2930011883682	7X677	23500012	WATER OUTLET,ENGINE 6.2 LITER..... UOC:AVY,A11,A13,A14,A15,A20,A24,A25,A26,A27,B16,B17,B18,HVY,H11,H13,H14,H15,H16,H17,H18,H20,H21,H24,H25,H26,H27,H28,MMM	1
19	PAOZZ	4730000412526	79470	1069X6	ELBOW,PIPE TO HOSE.....	1

END OF FIGURE

3 — 

4 and 5
---------------

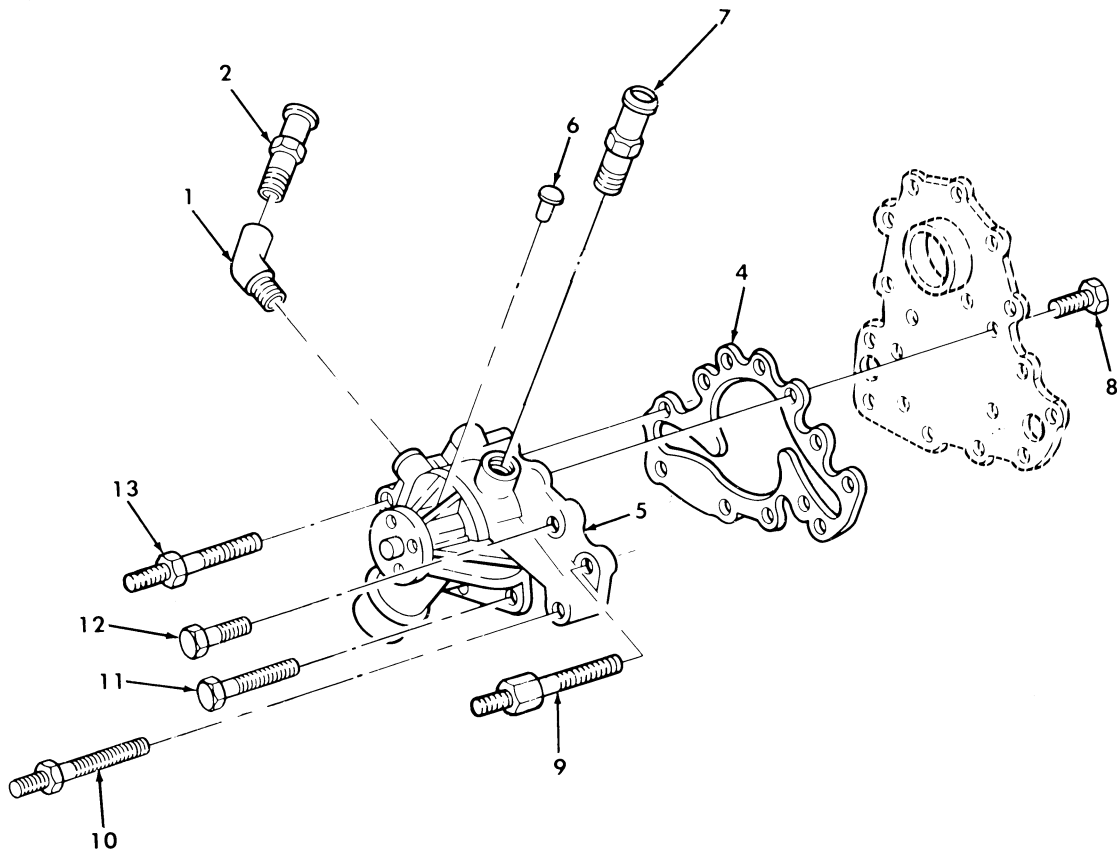
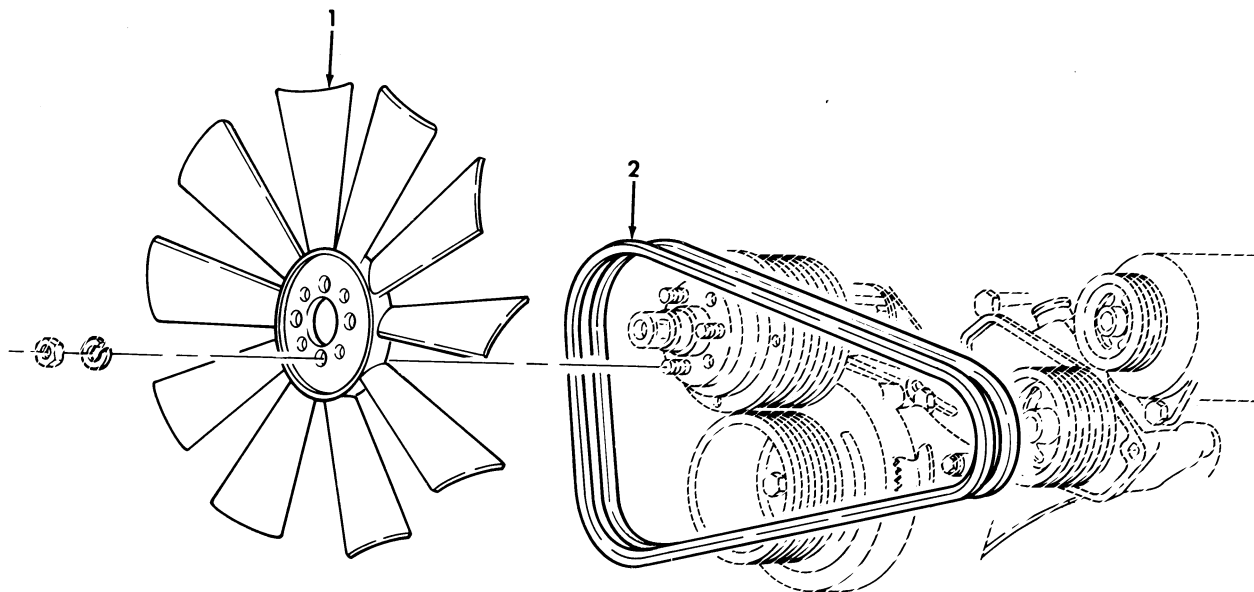

Figure 31. Water Pump and Attaching Hardware.

SECTION II			TM9-2320-280-24P			
(1)	(2)	(3)	(4)	(5)	(6)	(7)
ITEM NO	SMR CODE	NSN	CAGEC	PART NUMBER	DESCRIPTION AND USABLE ON CODES(UOC)	QTY
GROUP 0504 WATER PUMP						
FIG. 31 WATER PUMP AND ATTACHING HARDWARE						
1	PAOZZ	4730005410793	30327	75167	ELBOW,PIPE.....	1
2	PAOZZ	4730011482758	7X677	354501	ADAPTER,STRAIGHT,PI.....	1
3	PAOZZ	2930011937802	7X677	15633485	PUMP,COOLING SYSTEM 6.2 LITER,USE PRIOR TO 1990 ENGINE.....	1
					UOC:H11,H13,H14,H15,H16,H17,H18,H20, H21,H24,H25,H26,H27,H28,MMM	
3	PAOZZ	2930013535794	61928	251-591	PUMP,COOLING SYSTEM 6.2 AND 6.5 DETUNED,USE WITH 1990 ENGINE AND ABOVE.....	1
					UOC:AVY,A11,A13,A14,A15,A20,A24,A25, A26,A27,B16,B17,B18,HVY,H11,H13,H14, H15,H16,H17,H18,H20,H21,H24,H25,H26, H27,H28,MMM	
3	PAOZZ	2930014446649	7X677	12534772	PUMP,COOLING SYSTEM 6.5 LITER.....	1
					UOC:BVY,B15,B20,B24,B25,C17,NNN	
4	PAOZZ	5330011479808	7X677	10137492	.GASKET 6.2 LITER AND 6.5 DETUNED..	1
					UOC:AVY,A11,A13,A14,A15,A20,A24,A25, A26,A27,B16,B17,B18,HVY,H11,H13,H14, H15,H16,H17,H18,H20,H21,H24,H25,H26, H27,H28,MMM	
4	PAOZZ	5330014763866	7X677	12553488	.GASKET 6.5 LITER.....	1
					UOC:BVY,B15,B20,B24,B25,C17,NNN	
5	XAOZZ		7X677	23500085	.PUMP,COOLING SYSTEM 6.2 LITER AND 6.5 DETUNED.....	1
					UOC:AVY,A11,A13,A14,A15,A20,A24,A25, A26,A27,B16,B17,B18,HVY,H11,H13,H14, H15,H16,H17,H18,H20,H21,H24,H25,H26, H27,H28,MMM	
5	XAOZZ		7X677	12553484	.PUMP,COOLING SYSTEM 6.5 LITER.....	1
					UOC:BVY,B15,B20,B24,B25,C17,NNN	
6	PFOZZ	5320012180721	7X677	193620	RIVET,SOLID 1/4 X 1/2.....	1
7	PAOZZ	4730011826565	7X677	3739798	ADAPTER,STRAIGHT,PI.....	1
8	PAOZZ	5305011491938	7X677	11500815	SCREW,CAP,HEXAGON H 6.2 AND 6.5 DETUNED 1.25 X 16MM.....	7
					UOC:AVY,A11,A13,A14,A15,A20,A24,A25, A26,A27,B16,B17,B18,HVY,H11,H13,H14, H15,H16,H17,H18,H20,H21,H24,H25,H26, H27,H28,MMM	
8	PAOZZ	5305011491938	7X677	11500815	SCREW,CAP,HEXAGON H 6.5 LITER, 8- 1.25 X 16MM.....	6
					UOC:BVY,B15,B20,B24,B25,C17,NNN	
9	PAOZZ	5307012079004	7X677	23500032	STUD SPECIAL 10-1.5 X 89 X 15MM....	1
10	PAOZZ	5307011787445	7X677	14024229	STUD,SHOULDERED 10-1.5 X 95 X 17MM.	1
11	PAOZZ	5305011499673	24617	1150967	SCREW,CAP,HEXAGON H 10-1.5 X 90MM..	1
12	PAOZZ	5306011501190	7X677	11500921	BOLT,MACHINE 10-1.5 X 40 MM.....	2
13	PAOZZ	5307011501549	7X677	14045263	STUD,SHOULDERED 8-1.25 X 16.75 X 25 MM.....	1

END OF FIGURE

**USE WITH BASIC AND A1 VEHICLES**



---

**USE WITH A2 VEHICLES**

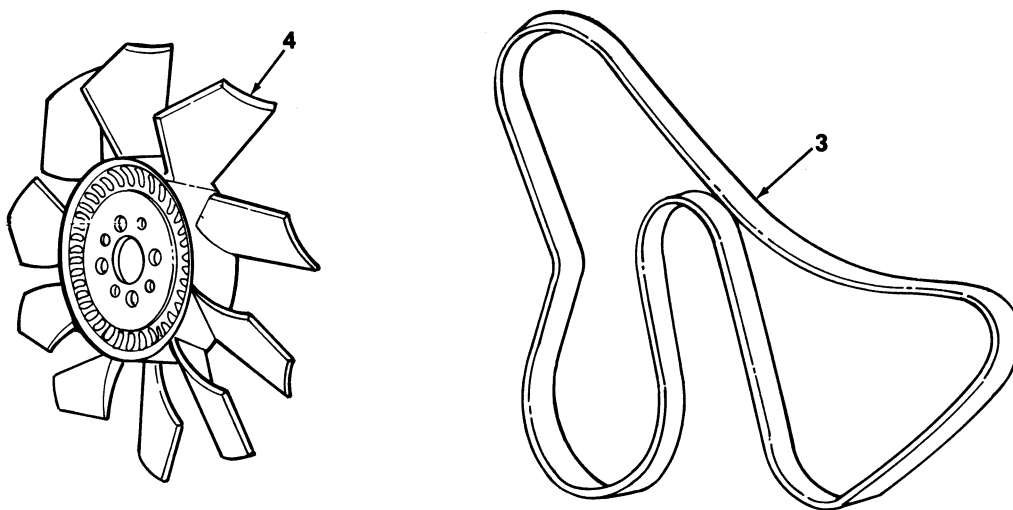

*Figure 32. Fan Assemblies and Belts.*



SECTION II			TM9-2320-280-24P			
(1)	(2)	(3)	(4)	(5)	(6)	(7)
ITEM	SMR			PART		
NO	CODE	NSN	CAGEC	NUMBER	DESCRIPTION AND USABLE ON CODES(UOC)	QTY
GROUP 0505 FAN ASSEMBLY						
FIG. 32 FAN ASSEMBLIES,BELTS, TENSIONER,IDLER PULLEY,AMD MOUNTING HARDWARE						
1	PAOZZ	4140012118403	51377	4735-38449-02	IMPELLER,FAN,CENTRI..... UOC:AVY,A11,A13,A14,A15,A20,A24,A25, A26,A27,B16,B17,B18,HVY,H11,H13,H14, H15,H16,H17,H18,H20,H21,H24,H25,H26, H27,H28,MMM	1
2	PAOZZ	3030003792815	20796	43-5791	BELTS,V,MATCHED SET..... UOC:A11,A13,A14,A20,A24,A25,A26,A27, B17,B18,H11,H13,H14,H17,H18,H20,H21, H24,H25,H26,H27,H28,MMM	1
2	PAOZZ	3030012563616	34623	5598213	BELT,V..... UOC:AVY,A15,B16,HVY,H15,H16	1
3	PAOZA	3030014669476	0AKY3	20-8021	BELT,SERPENTINE ALL WEATHER..... UOC:BVY,B15,B20,B24,B25,C17,NNN	1
4	PAOZZ	2930014208622	51377	4735-42599-103	IMPELLER,FAN,AXIAL..... UOC:BVY,B15,B20,B24,B25,C17,NNN	1

END OF FIGURE

USE WITH A2 VEHICLES

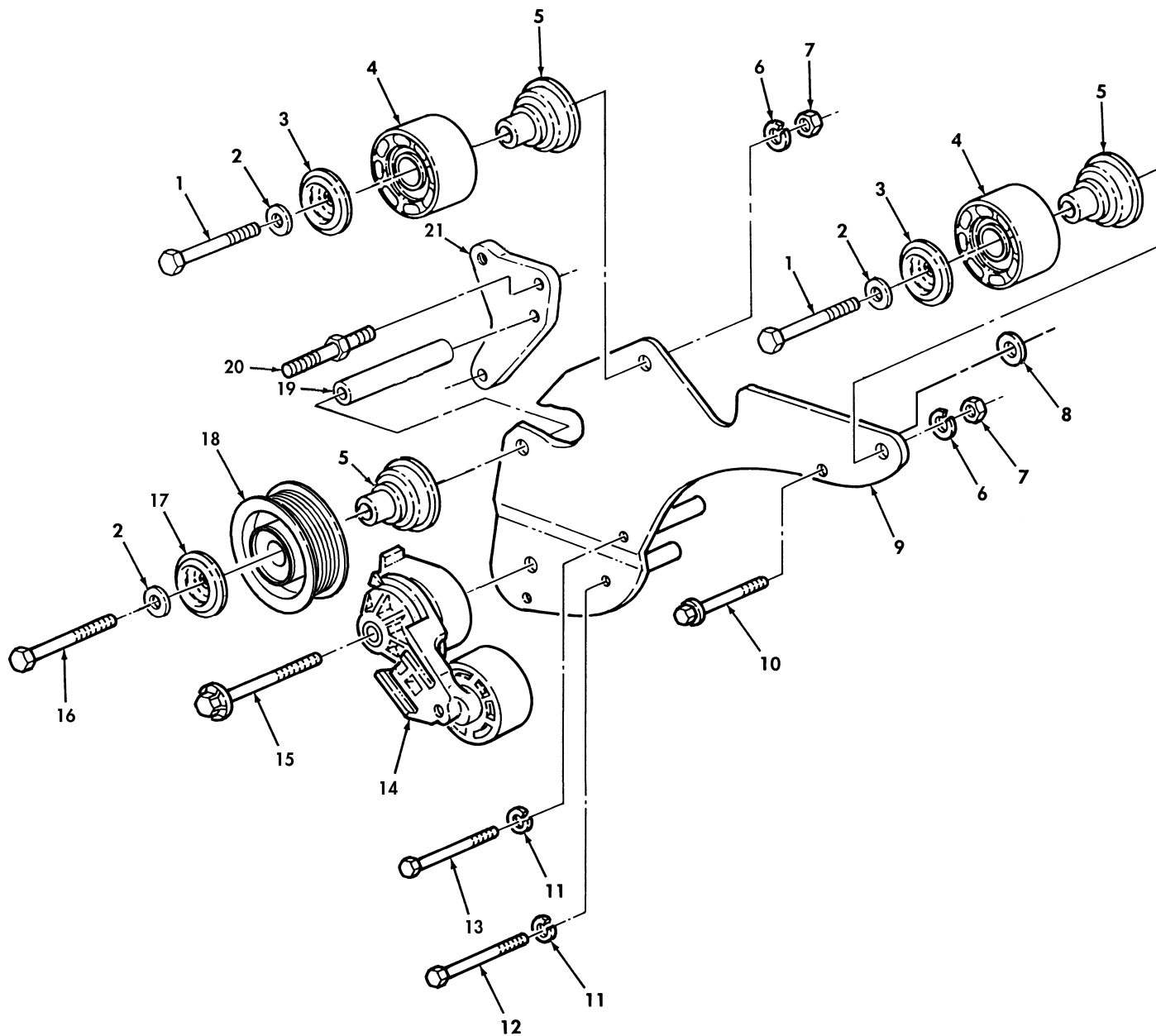
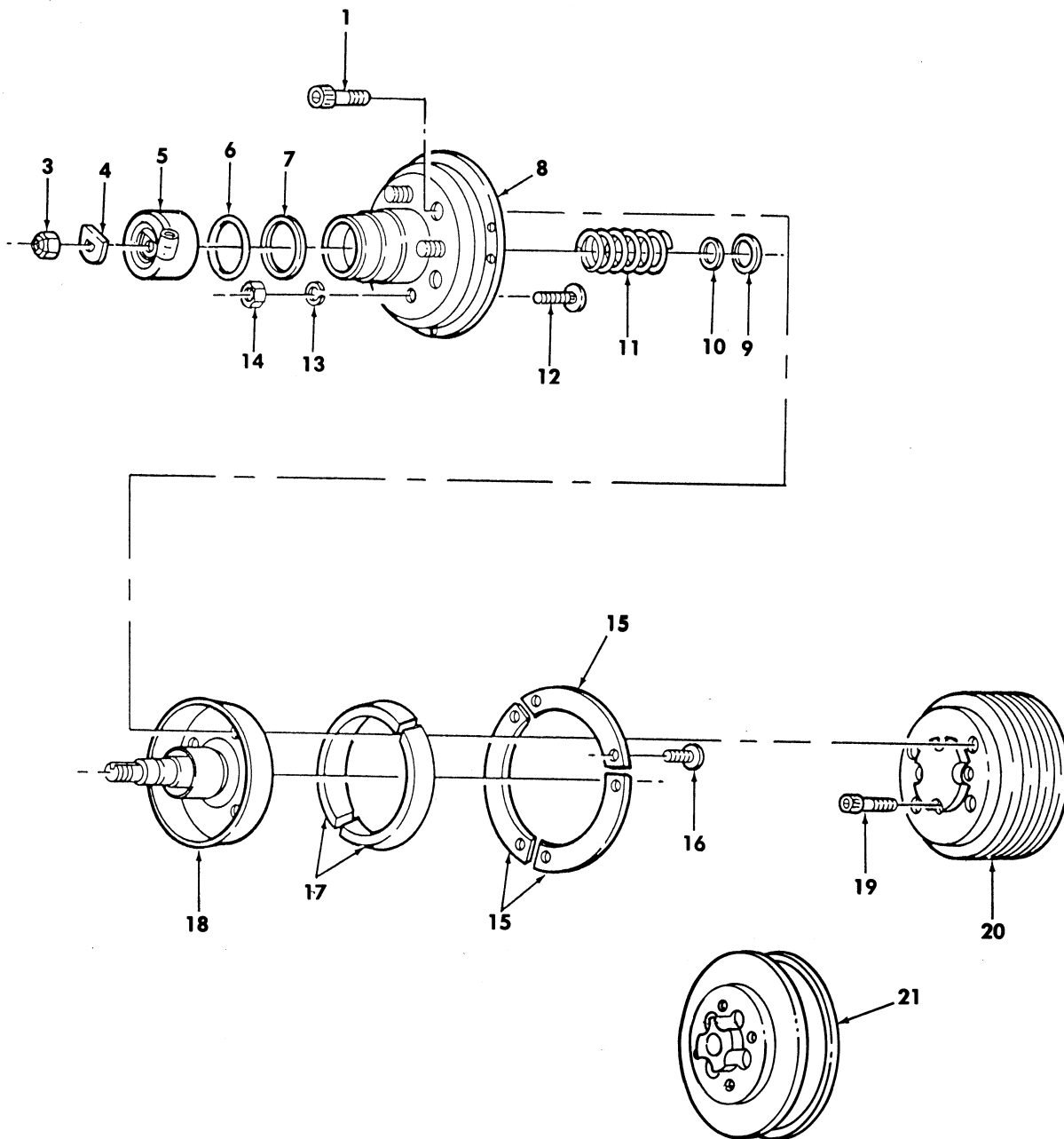

Figure 33. Tensioner, Idler Pulley, and Mounting Hardware.

SECTION II			TM9-2320-280-24P			
(1)	(2)	(3)	(4)	(5)	(6)	(7)
ITEM	SMR			PART		
NO	CODE	NSN	CAGEC	NUMBER	DESCRIPTION AND USABLE ON CODES(UOC)	QTY
GROUP 0505 FAN ASSEMBLY						
FIG. 33 TENSIONER, IDLER PULLEY, AND MOUNTING HARDWARE						
1	PAOZZ	5305000712074	80204	B1821BH050C275N	SCREW, CAP, HEXAGON H..... UOC: BVY, B20, B24, B25, C17, NNN	2
2	PAOZZ	5310008095998	80063	SCD13617-8	WASHER, FLAT..... UOC: BVY, B20, B24, B25, C17, NNN	3
3	PAOZZ	3020014580185	34623	RCSK18627	COVER, IDLER PULLEY..... UOC: BVY, B20, B24, B25, C17, NNN	2
4	PAOZZ	3020014621202	34623	RCSK18628	PULLEY, FLAT..... UOC: BVY, B20, B24, B25, C17, NNN	2
5	PAOZZ	3020014580176	34623	RCSK18626	SPACER, IDLER PULLEY..... UOC: BVY, B20, B24, B25, C17, NNN	3
6	PAOZZ	5310004829493	24617	120384	WASHER, LOCK..... UOC: BVY, B20, B24, B25, C17, NNN	2
7	PAOZZ	5310014654525	24617	9418753	NUT, PLAIN, HEXAGON..... UOC: BVY, B20, B24, B25, C17, NNN	2
8	PAOZZ		34623	5934761	WASHER, SHOULDERED..... UOC: BVY, B20, B24, B25, C17, NNN	1
9	PAOZZ	2590014443317	34623	RCSK18278-6	BRACKET, VEHICULAR C..... UOC: BVY, B20, B24, B25, C17, NNN	1
10	PAOZZ	5306014731895	24617	11501619	BOLT, MACHINE..... UOC: BVY, B20, B24, B25, C17, NNN	1
11	PAOZZ	5310012067306	7X677	11500207	WASHER, LOCK..... UOC: BVY, B20, B24, B25, C17, NNN	2
12	PAOZZ	5306014327900	24617	11504617	BOLT, MACHINE..... UOC: BVY, B20, B24, B25, C17, NNN	1
13	PAOZZ	5306014472568	24617	11504594	BOLT, MACHINE..... UOC: BVY, B20, B24, B25, C17, NNN	1
14	PAOZZ	2920014207894	19207	12460353	TENSIONER..... UOC: BVY, B20, B24, B25, C17, NNN	1
15	PAOZZ	5305013601136	73342	11505328	SCREW, CAP, HEXAGON H..... UOC: BVY, B20, B24, B25, C17, NNN	1
16	PAOZZ		80204	B1821BH050C775N	SCREW, CAP, HEXAGON H..... UOC: BVY, B20, B24, B25, C17, NNN	1
17	PAOZZ		19207	12380024	COVER, IDLER PULLEY..... UOC: BVY, B20, B24, B25, C17, NNN	1
18	PAOZZ	3020014441665	34623	RCSK18690	PULLEY, GROOVE..... UOC: BVY, B20, B24, B25, C17, NNN	1
19	PAOZZ		34623	RCSK18683	SPACER, SLEEVE..... UOC: BVY, B20, B24, B25, C17, NNN	1
20	PAOZZ	5307014084029	19207	12342545	STUD, SHOULDERED..... UOC: BVY, B20, B24, B25, C17, NNN	1
21	PAOZZ		19207	12469107	ADAPTER..... UOC: BVY, B20, B24, B25, C17, NNN	1

END OF FIGURE

2—  
3  
thru  
18



**USE WITH A2 VEHICLES**

Figure 34. Fan Drive and Pulley.

SECTION II			TM9-2320-280-24P			
(1)	(2)	(3)	(4)	(5)	(6)	(7)
ITEM NO	SMR CODE	NSN	CAGEC	PART NUMBER	DESCRIPTION AND USABLE ON CODES(UOC)	QTY
GROUP 0505 FAN ASSEMBLY						
FIG. 34 FAN DRIVE AND PULLEY						
1	PAOZZ	5305003663337	24617	138242	SCREW 3/8-16 X 1.00.....	4
2	PAOFF	2930011687870	51377	1090-06404-01	IMPELLER,FAN,AXIAL.....	1
3	PAFZZ	5310011940481	51377	3029-01371-01	.NUT,SELF-LOCKING,HE.....	1
4	PAFZZ	5310011898468	51377	3058-01264-02	.WASHER,FLAT.....	1
5	PAFZZ	2930011891744	51377	4043-38443-01	.CYLINDER ASSEMBLY,F.....	1
6	PAFZZ	5331011928892	51377	3018-01265-01	.O-RING.....	1
7	PAFZZ	5330012478438	51377	3018-01339-01	.SEAL,DUST.....	1
8	XAFZZ		51377	4040-38442-01	.HOUSING ASSEMBLY.....	1
9	PAFZZ	5331011951500	51377	9002-00741-58	.O-RING.....	1
10	PAFZZ	5331011948966	51377	9002-00181-48	.O-RING.....	1
11	PAFZZ	5360011906214	51377	4088-35869-01	.SPRING,HELICAL,COMP.....	1
12	PAFZZ	5307011905854	51377	3051-01405-01	.STUD,PLAIN 3/8-24 X 1.16.....	4
13	PAOZZ	5310006379541	96906	MS35338-46	.WASHER,LOCK.....	4
14	PAOZZ	5310011904607	51377	3030-00364-01	.NUT,PLAIN,HEXAGON 3/8-16.....	4
15	XAOZZ		51377	4073-38424-01	.LINING,FAN CLUTCH.....	3
16	PAOZZ	5305000526456	80205	MS16996-10	.SCREW,CAP,SOCKET HE.....	6
17	PAOZZ	2930011898643	51377	4026-38368-01	.LINING,FRICITION.....	2
18	XAFZZ		51377	4079-38441-01	.SHAFT ASSEMBLY.....	1
19	PAOZZ	5305011893769	19207	12339240	SCREW,CAP,SOCKET HE 8-1.25 X 20MM..	4
20	PAOZZ	3020013130682	19207	12338782	PULLEY,CONE.....	1
					UOC:A15,H15	
20	PAOZZ	3020011883885	19207	12338781	PULLEY,GROOVE.....	1
					UOC:AVY,A11,A13,A14,A20,A24,A25,A26,A27,B16,B17,B18,HVY,H11,H13,H14,H16,H17,H18,H20,H21,H24,H25,H26,H27,H28,MMM	
21	PAOZZ	3020014427278	34623	RCSK18221	PULLEY,FLAT.....	1
					UOC:BVY,B15,B20,B24,B25,C17,NNN	

END OF FIGURE

6  
7  
thru  
13

USE WITH BASIC AND A1 VEHICLES (60 AMP)

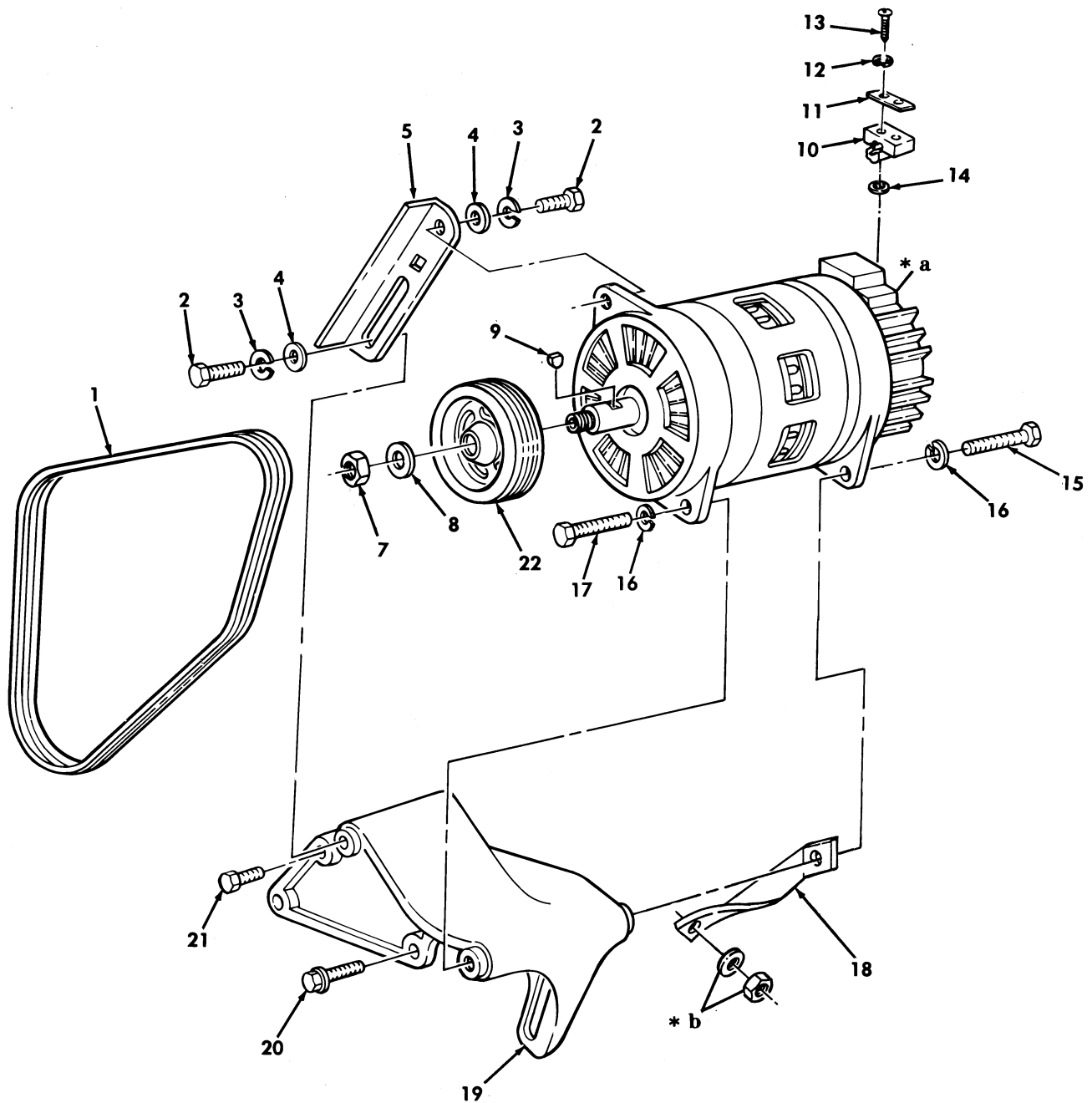

- \* a PART OF ITEM 6
- \* b SEE FIGURE 42

Figure 35. Generator, 60 AMP, 100 AMP, Belts, Pulley, and Mounting Hardware.

SECTION II			TM9-2320-280-24P			
(1)	(2)	(3)	(4)	(5)	(6)	(7)
ITEM	SMR			PART		
NO	CODE	NSN	CAGEC	NUMBER	DESCRIPTION AND USABLE ON CODES(UOC)	QTY
GROUP 06 ELECTRICAL SYSTEM						
0601 GENERATOR: ALTERNATOR						
FIG. 35 GENERATOR, 60 AMP,100 AMP,						
BELTS,PULLY,AND MOUNTING HARDWARE						
1	PAOZZ	3030012826968	34623	12339359-12	BELTS,V,MATCHED SET.....	1
UOC:A11,A13,A14,A20,A24,A25,A26,A27,						
B17,B18,H11,H13,H14,H17,H18,H20,H21,						
H24,H25,H26,H27,H28,MMM						
2	PAOZZ	5305000680510	80204	B1821BH038C100N	SCREW,CAP,HEXAGON H 3/8-16 X 1.00..	2
UOC:A11,A13,A14,A20,A24,A25,A26,A27,						
B17,B18,H11,H13,H14,H17,H18,H20,H21,						
H24,H25,H26,H27,H28,MMM						
3	PAOZZ	5310006379541	96906	MS35338-46	WASHER,LOCK 3/8.....	2
UOC:A11,A13,A14,A20,A24,A25,A26,A27,						
B17,B18,H11,H13,H14,H17,H18,H20,H21,						
H24,H25,H26,H27,H28,MMM						
4	PAOZZ	5310014124013	24617	2436163	WASHER,FLAT 3/8.....	2
UOC:A11,A13,A14,A20,A24,A25,A26,A27,						
B17,B18,H11,H13,H14,H17,H18,H20,H21,						
H24,H25,H26,H27,H28,MMM						
5	PAOZZ	2920011687914	19207	12338792	GENERATOR BRACKET.....	1
UOC:A11,A13,A14,A20,A24,A25,A26,A27,						
B17,B18,H11,H13,H14,H17,H18,H20,H21,						
H24,H25,H26,H27,H28,MMM						
6	PAOZZ	2920009092483	19207	10929868	GENERATOR,ENGINE AC.....	1
UOC:A11,A13,A14,A20,A24,A25,A26,A27,						
B17,B18,H11,H13,H14,H17,H18,H20,H21,						
H24,H25,H26,H27,H28,MMM						
7	PAOZZ	5310004492381	96906	MS21245-L10	.NUT,SELF-LOCKING,HE 5/8-18.....	1
UOC:A11,A13,A14,A20,A24,A25,A26,A27,						
B17,B18,H11,H13,H14,H17,H18,H20,H21,						
H24,H25,H26,H27,H28,MMM						
8	PAOZZ	5310006143505	96906	MS15795-820	.WASHER,FLAT 5/8.....	1
UOC:A11,A13,A14,A20,A24,A25,A26,A27,						
B17,B18,H11,H13,H14,H17,H18,H20,H21,						
H24,H25,H26,H27,H28,MMM						
9	PAOZZ	5315006165526	80205	MS35756-8	.KEY,WOODRUFF.....	1
UOC:A11,A13,A14,A20,A24,A25,A26,A27,						
B17,B18,H11,H13,H14,H17,H18,H20,H21,						
H24,H25,H26,H27,H28,MMM						
10	PAOZZ	5365012894434	19207	12357116	.SPACER,PLATE.....	1
UOC:A11,A13,A14,A20,A24,A25,A26,A27,						
B17,B18,H11,H13,H14,H17,H18,H20,H21,						
H24,H25,H26,H27,H28,MMM						
11	PAOZZ	5365012897852	19207	12357126	.SPACER,PLATE.....	1
UOC:A11,A14,A15,A20,A24,A25,A26,A27,						
B17,B18,H11,H13,H14,H17,H18,H20,H21,						
H24,H25,H26,H27,H28,MMM						
12	PAOZZ	5310007217809	96906	MS35340-43	.WASHER,LOCK #10.....	2
UOC:A11,A13,A14,A20,A24,A25,A26,A27,						
B17,B18,H11,H13,H14,H17,H18,H20,H21,						

SECTION II			TM9-2320-280-24P			
(1)	(2)	(3)	(4)	(5)	(6)	(7)
ITEM	SMR			PART		
NO	CODE	NSN	CAGEC	NUMBER	DESCRIPTION AND USABLE ON CODES(UC)	QTY
13	PAOZZ	5305009846212	96906	MS35206-265	H24,H25,H26,H27,H28,MMM .SCREW,MACHINE #10-32 X 3/4.....	2
					UOC:A11,A13,A14,A20,A24,A25,A26,A27, B17,B18,H11,H13,H14,H17,H18,H20,H21, H24,H25,H26,H27,H28,MMM	
14	PAOZZ	5310012349416	96906	MS51412-2	WASHER,FLAT.....	2
					UOC:A11,A13,A14,A20,A24,A25,A26,A27, B17,B18,H11,H13,H14,H17,H18,H20,H21, H24,H25,H26,H27,H28,MMM	
15	PAOZZ	5306012760848	96906	MS35764-853	BOLT,SELF-LOCKING 7/16-14 X 2.0....	1
					UOC:A11,A13,A14,A20,A24,A25,A26,A27, B17,B18,H11,H13,H14,H17,H18,H20,H21, H24,H25,H26,H27,H28,MMM	
16	PAOZZ	5310002090965	96906	MS35338-47	WASHER,LOCK 7/16.....	2
					UOC:A11,A13,A14,A20,A24,A25,A26,A27, B17,B18,H11,H13,H14,H17,H18,H20,H21, H24,H25,H26,H27,H28,MMM	
17	PAOZZ	5305000712055	80204	B1821BH044C150N	SCREW,CAP,HEXAGON H 7/16-14 X 1.50.	1
					UOC:A11,A13,A14,A20,A24,A25,A26,A27, B17,B18,H11,H13,H14,H17,H18,H20,H21, H24,H25,H26,H27,H28,MMM	
18	PAOZZ	5340012930125	34623	5935091	BRACKET,MOUNTING.....	1
					UOC:A11,A13,A14,A20,A24,A25,A26,A27, B17,B18,H11,H13,H14,H17,H18,H20,H21, H24,H25,H26,H27,H28,MMM	
19	PAOZZ	5342012577706	34623	5597344	BRACKET,ENGINE ACCE.....	1
					UOC:AVY,A11,A13,A14,A20,A24,A25,A26, A27,B17,B18,H11,H13,H14,H17,H18,H20, H21,H24,H25,H26,H27,H28,MMM	
20	PAOZZ	5306012638889	19207	12340845-2	BOLT,MACHINE 10-1.5 X 30 MM.....	1
					UOC:A11,A13,A14,A20,A24,A25,A26,A27, B17,B18,H11,H13,H14,H17,H18,H20,H21, H24,H25,H26,H27,H28,MMM	
21	PAOZZ	5306012705448	19207	12340845-3	BOLT,MACHINE 10-1.5 X 45 MM.....	1
					UOC:A11,A13,A14,A20,A24,A25,A26,A27, BVY,B17,B18,H11,H13,H14,H17,H18,H20, H21,H24,H25,H26,H27,H28,MMM,NNN	
22	PAOZZ	3020011980633	19207	12339395	PULLEY,GROOVE.....	1
					UOC:A11,A13,A14,A20,A24,A25,A26,A27, B17,B18,H11,H13,H14,H17,H18,H20,H21, H24,H25,H26,H27,H28,MMM	

END OF FIGURE



USE WITH A2 VEHICLES

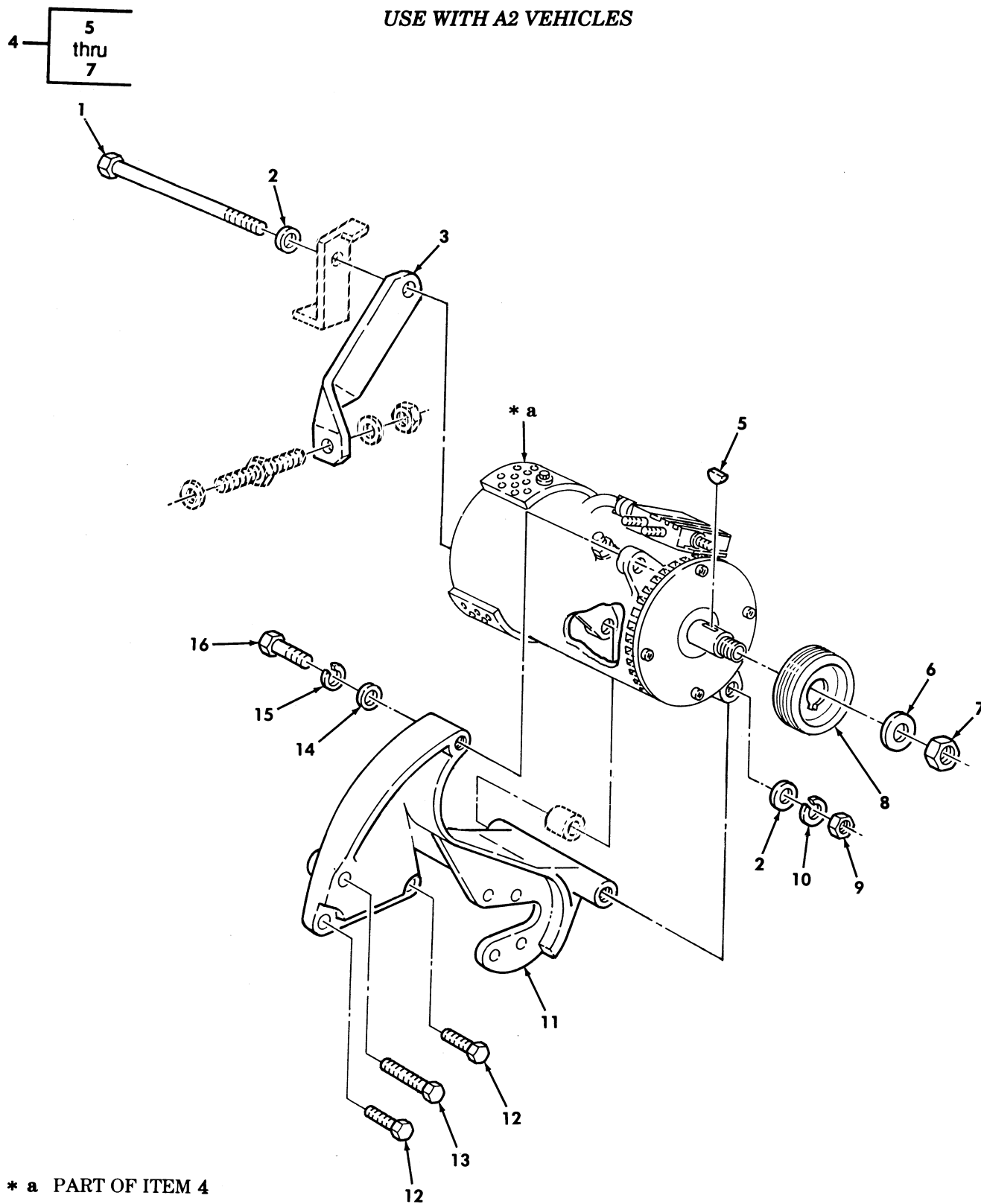
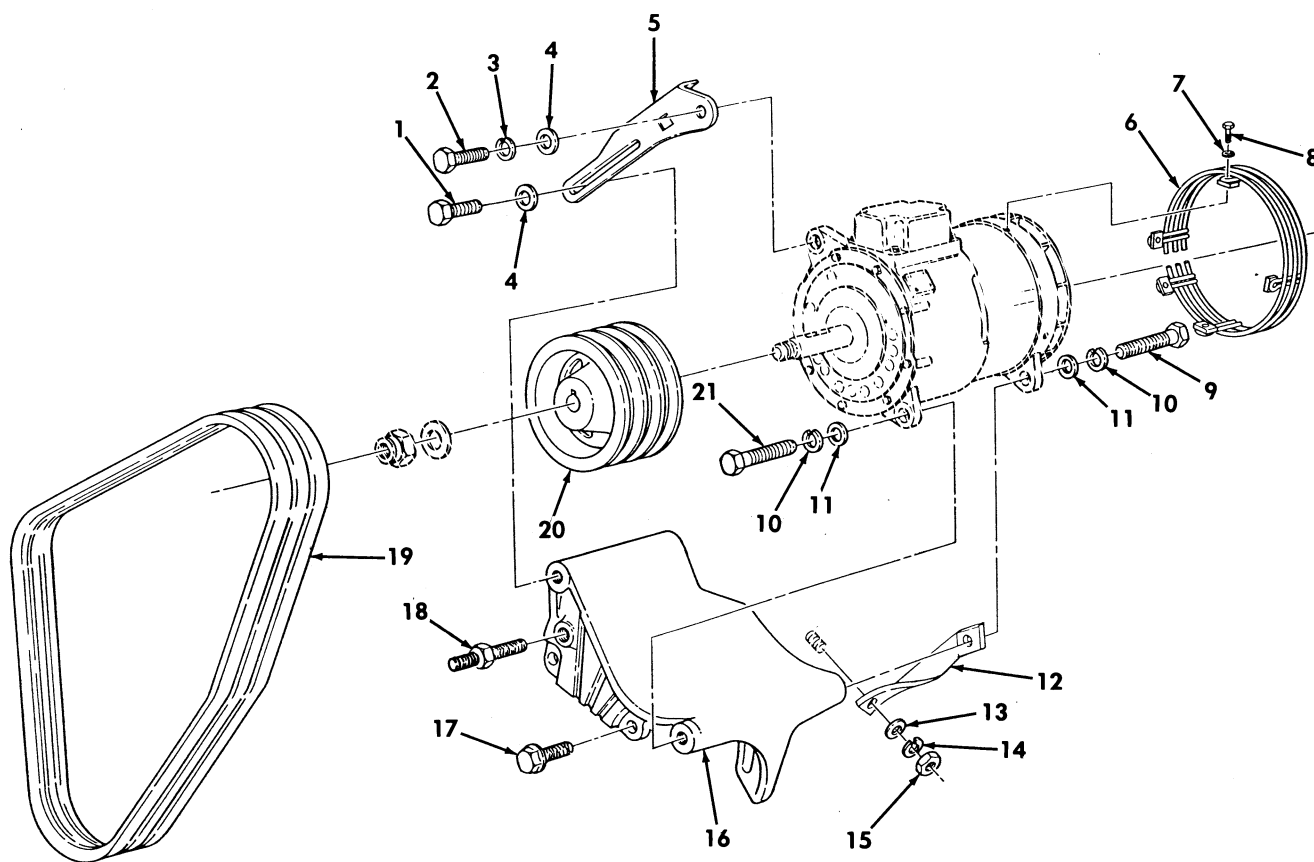

Figure 36. 100 AMP Alternator (NIEHOFF) and Mounting Hardware.

SECTION II			TM9-2320-280-24P			
(1)	(2)	(3)	(4)	(5)	(6)	(7)
ITEM	SMR			PART		
NO	CODE	NSN	CAGEC	NUMBER	DESCRIPTION AND USABLE ON CODES(UOC)	QTY
GROUP 0601 GENERATOR: ALTERNATOR						
FIG. 36 100 AMP ALTERNATOR (NIEHOFF) AND MOUNTING HARDWARE						
1	PAOZZ	5305014299149	80204	B1821BH044F975N	SCREW,CAP,HEXAGON H 7/16-20 X 9-3/4 UOC:B20,B24,B25,C17	1
2	PAOZZ	5310008094085	96906	MS27183-16	WASHER,FLAT 7/16..... UOC:B20,B24,B25,C17	2
3	PAOZZ	5342014468954	34623	RCSK17712	BRACKET,ENGINE ACCE..... UOC:B20,B24,B25,C17	1
4	PAOFF	2920014070532	19207	12447110	GENERATOR,ENGINE AC 100 AMP..... UOC:B20,B24,B25,C17	1
5	PAOZZ	5315000124553	80205	MS35756-17	.KEY,WOODRUFF..... UOC:B20,B24,B25,C17	1
6	PAOZZ	5310007720442	19207	7720442	.WASHER,FLAT 3/4..... UOC:B20,B24,B25,C17	1
7	PAOZZ	5310004190876	96906	MS21245-L12	.NUT,SELF-LOCKING,HE 3/4-16..... UOC:B20,B24,B25,C17	1
8	PAOZZ	3020014732048	34623	RCSK18220	PULLEY,GROOVE..... UOC:B20,B24,B25,C17	1
9	PAOZZ	5310014573171	24617	9417028	NUT,PLAIN,HEXAGON 7/16-20..... UOC:B20,B24,B25,C17	1
10	PAOZZ	5310002090965	96906	MS35338-47	WASHER,LOCK 7/16..... UOC:B20,B24,B25,C17	1
11	PAOZZ	2920014731763	19207	12460442	ARM,ADJUSTING,BELT..... UOC:B20,B24,B25,C17	1
12	PAOZZ	5306012638889	19207	12340845-2	BOLT,MACHINE 10-1.5 X 30 MM..... UOC:B20,B24,B25,C17	2
13	PAOZZ	5306012705448	19207	12340845-3	BOLT,MACHINE 10-1.5 X 45MM..... UOC:B20,B24,B25,C17	1
14	PAOZZ	5310014124013	24617	2436163	WASHER,FLAT 3/8..... UOC:B20,B24,B25,C17	1
15	PAOZZ	5310006379541	96906	MS35338-46	WASHER,LOCK 3/8..... UOC:B20,B24,B25,C17	2
16	PAOZZ	5305007252317	80204	B1821BH038C150N	SCREW,CAP,HEXAGON H .375-16 X 1.50. UOC:B20,B24,B25,C17	1
17	PAOZZ	5310012101587	7X677	11500256	WASHER,FLAT..... UOC:B20,B24,B25,C17	2
18	PAOZZ	5307013153597	19207	12339406-3	STUD,SHOULDERED..... UOC:B20,B24,B25,C17	1
19	PAOZZ	5310012067306	7X677	11500207	WASHER,LOCK..... UOC:B20,B24,B25,C17	1
20	PAOZZ	5310013958747	80204	B18241B100F	NUT,PLAIN,HEXAGON 1/4-28..... UOC:B20,B24,B25,C17	1

END OF FIGURE

**USE WITH BASIC AND A1 VEHICLES**



*Figure 37. 200 AMP Alternator Assembly, Belts, Pulley, Guard, and Mounting Hardware. M996, M996A1, M997, M997A1, M1097, and M1097A1.*

SECTION II			TM9-2320-280-24P			
(1)	(2)	(3)	(4)	(5)	(6)	(7)
ITEM	SMR			PART		
NO	CODE	NSN	CAGEC	NUMBER	DESCRIPTION AND USABLE ON CODES(UOC)	QTY
GROUP 0601 GENERATOR: ALTERNATOR						
FIG. 37 200 AMP ALTERNATOR ASSEMBLY, BELTS,PULLEY,GUARD,AND MOUNTING HARDWARE,M996,M996A1,M997,M997A1, M1097,AND M1097A1						
1	PAOZZ	5306011140963	80204	B1821BH038C100L	BOLT,MACHINE 3/8-16 X 1.00.....	1
					UOC:AVY,A15,B16,HVY,H15,H16	
2	PAOZZ	5305000680510	80204	B1821BH038C100N	SCREW,CAP,HEXAGON H 3/8-16 X 1.00..	1
					UOC:AVY,A15,B16,HVY,H15,H16	
3	PAOZZ	5310006379541	96906	MS35338-46	WASHER,LOCK 3/8.....	1
					UOC:AVY,A15,B16,HVY,H15,H16	
4	PAOZZ	5310000877493	96906	MS27183-13	WASHER,FLAT 3/8.....	2
					UOC:AVY,A15,B16,HVY,H15,H16	
5	PFOZZ	5340011975548	19207	12340057	BRACKET,ENGINE ACCE.....	1
					UOC:AVY,A15,B16,HVY,H15,H16	
6	PFOZZ	3040012709466	19207	12341809	GUARD,MECHANICAL DR.....	1
					UOC:AVY,A15,B16,HVY,H15,H16	
7	PAOZZ	5310012349416	96906	MS51412-2	WASHER,FLAT #10.....	5
					UOC:AVY,A15,B16,HVY,H15,H16	
8	PAOZZ	5305005829501	82386	410-63	SCREW,CAP,HEXAGON H #10-32 X 50....	5
					UOC:AVY,A15,B16,HVY,H15,H16	
9	PAOZZ	5305000712059	80204	B1821BH044C250N	SCREW,CAP,HEXAGON H 7/16-14 X 2.50.	1
					UOC:AVY,A15,B16,HVY,H15,H16	
10	PAOZZ	5310002090965	96906	MS35338-47	WASHER,LOCK 7/16.....	2
					UOC:AVY,A15,B16,HVY,H15,H16	
11	PAOZZ	5310008094061	96906	MS27183-15	WASHER,FLAT 7/16.....	2
					UOC:AVY,A15,B16,HVY,H15,H16	
12	PFOZZ	5340012928404	34623	5935092	BRACKET,MOUNTING REAR.....	1
					UOC:AVY,A15,B16,HVY,H15,H16	
13	PAOZZ	5310012101587	7X677	11500256	WASHER,FLAT 10MM.....	1
					UOC:AVY,A15,B16,HVY,H15,H16	
14	PAOZZ	5310012067306	7X677	11500207	WASHER,LOCK 10MM.....	1
					UOC:AVY,A15,B16,HVY,H15,H16	
15	PAOZZ	5310013958747	80204	B18241B100F	NUT,PLAIN,HEXAGON 10MM.....	1
					UOC:AVY,A15,B16,HVY,H15,H16	
16	PAOZZ	2590014444365	34623	12338786-1	BRACKET,VEHICULAR C.....	1
					UOC:AVY,A15,B16,HVY,H15,H16	
17	PAOZZ	5306012638889	19207	12340845-2	BOLT,MACHINE 10-1.5 X 30 MM.....	2
					UOC:AVY,A15,B16,HVY,H15,H16	
18	PAOZZ	5307014084029	19207	12342545	STUD,SHOULDERED.....	1
					UOC:AVY,A15,B16,HVY,H15,H16	
19	PAOZZ	3030013214482	19207	12339359-18	BELTS,V,MATCHED SET (SET OF 3), .38 X 64.50.....	1
					UOC:AVY,A15,B16,HVY,H15,H16	
19	PAOZZ	3030013332286	19207	12339359-26	BELT,V.....	1
					UOC:AVY,A15,B16,HVY,H15,H16	
20	PFOZZ	3020012329629	19207	12339392	PULLEY,GROOVE.....	1
					UOC:AVY,A15,B16,HVY,H15,H16	
21	PAOZZ	5305000712057	80204	B1821BH044C200N	SCREW,CAP,HEXAGON H 7/16-14 X 2.00.	1
					UOC:AVY,A15,B16,HVY,H15,H16	

END OF FIGURE

Section II.

TM 9-2320-280-24P-1

USE WITH A2 VEHICLES

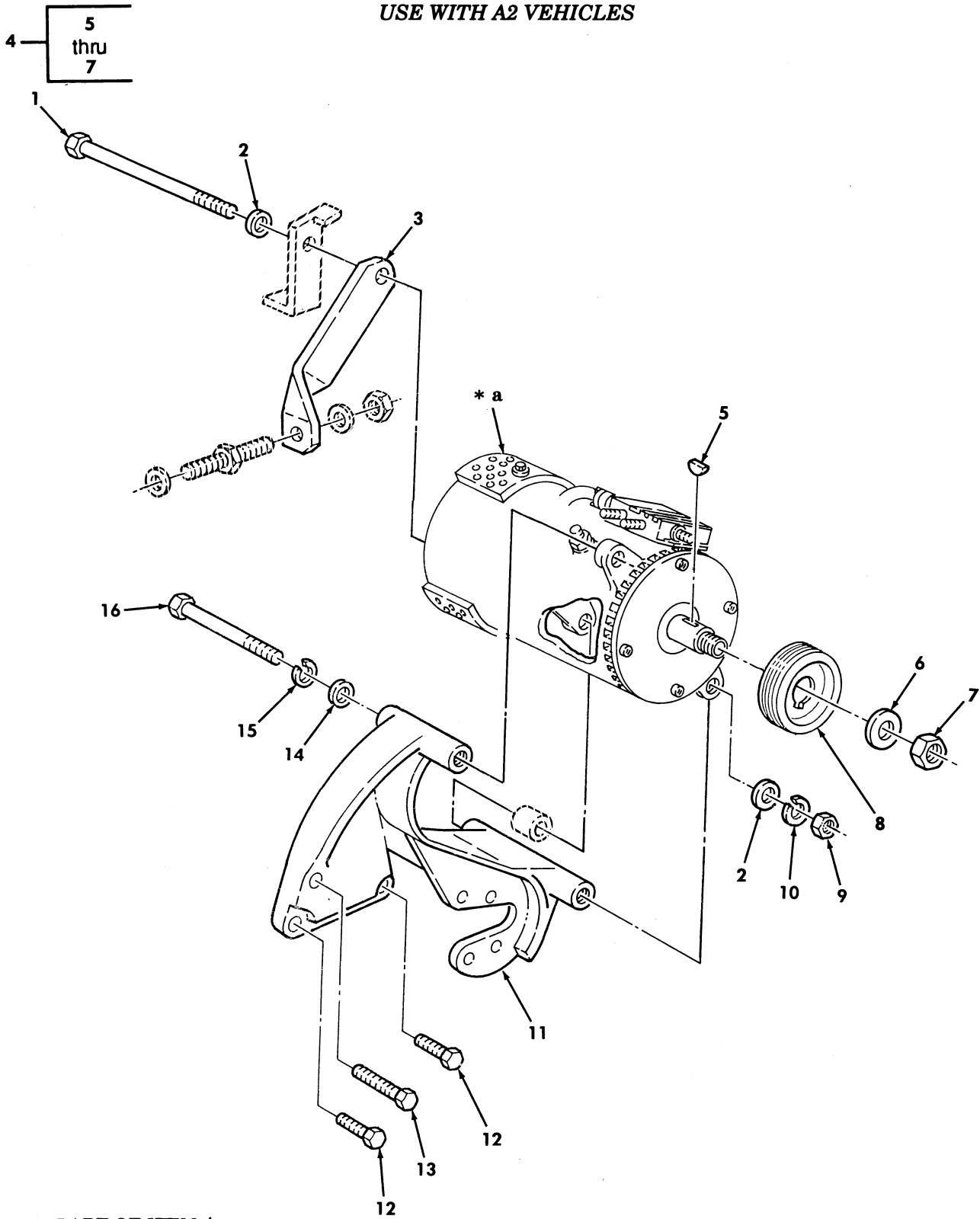

Figure 38. 200 AMP Alternator (NIEHOFF) Mounting Hardware.

SECTION II			TM9-2320-280-24P			
(1)	(2)	(3)	(4)	(5)	(6)	(7)
ITEM	SMR			PART		
NO	CODE	NSN	CAGEC	NUMBER	DESCRIPTION AND USABLE ON CODES(UOC)	QTY
GROUP 0601 ALTERNATOR						
FIG. 38 200 AMP ALTERNATOR (NIEHOFF)						
MOUNTING HARDWARE						
1	PAOZZ	5305014299149	80204	B1821BH044F975N	SCREW,CAP,HEXAGON H 7/16-20 X 9.75. UOC:BVY,B15,NNN	1
2	PAOZZ	5310008094085	96906	MS27183-16	WASHER,FLAT..... UOC:BVY,B15,NNN	2
3	PAOZZ	5340012928404	34623	5935092	BRACKET,MOUNTING..... UOC:BVY,B15,NNN	1
4	PAOFF	2920014209968	19207	12447109	GENERATOR,ENGINE AC 200 AMP..... UOC:BVY,B15,NNN	1
5	PAOZZ	5315000124553	80205	MS35756-17	.KEY,WOODRUFF..... UOC:BVY,B15,NNN	1
6	PAOZZ	5310007720442	19207	7720442	.WASHER,FLAT..... UOC:BVY,B15,NNN	1
7	PAOZZ	5310004190876	96906	MS21245-L12	.NUT,SELF-LOCKING,HE..... UOC:BVY,B15,NNN	1
8	PAOZZ	3020014445447	34623	RCSK-18685	PULLEY,GROOVE..... UOC:BVY,B15,NNN	1
9	PAOZZ	5310014573171	24617	9417028	NUT,PLAIN,HEXAGON 7/16-20..... UOC:BVY,B15,NNN	1
10	PAOZZ	5310002090965	96906	MS35338-47	WASHER,LOCK 7/16..... UOC:BVY,B15,NNN	1
11	PAOZZ	2920014442749	34623	RCSK18268	ARM,ADJUSTING,BELT..... UOC:BVY,B15,NNN	1
12	PAOZZ	5306012638889	19207	12340845-2	BOLT,MACHINE M10-1.5 X 30MM..... UOC:BVY,B15,NNN	2
13	PAOZZ	5306012705448	19207	12340845-3	BOLT,MACHINE..... UOC:BVY,B15,NNN	1
14	PAOZZ	5310014124013	24617	2436163	WASHER,FLAT 3/8..... UOC:B15,C17,NNN	1
15	PAOZZ	5310006379541	96906	MS35338-46	WASHER,LOCK 3/8..... UOC:BVY,B15,NNN	1
16	PAOZZ	5305014460767	80204	B1821BH038C575N	SCREW,CAP,HEXAGON H .375-16 X 5.75. UOC:BVY,B15,NNN	1
17	PAOZZ	5310012101587	7X677	11500256	WASHER,FLAT..... UOC:BVY,B15,NNN	2
18	PAOZZ	5307013153597	19207	12339406-3	STUD,SHOULDERED..... UOC:BVY,B15,NNN	1
19	PAOZZ	5310012067306	7X677	11500207	WASHER,LOCK..... UOC:BVY,B15,NNN	1
20	PAOZZ	5310013958747	80204	B18241B100F	NUT,PLAIN,HEXAGON 1/4-28..... UOC:BVY,B15,NNN	1

END OF FIGURE

**USE WITH BASIC AND A1 VEHICLES**

1 —  
2  
thru  
79

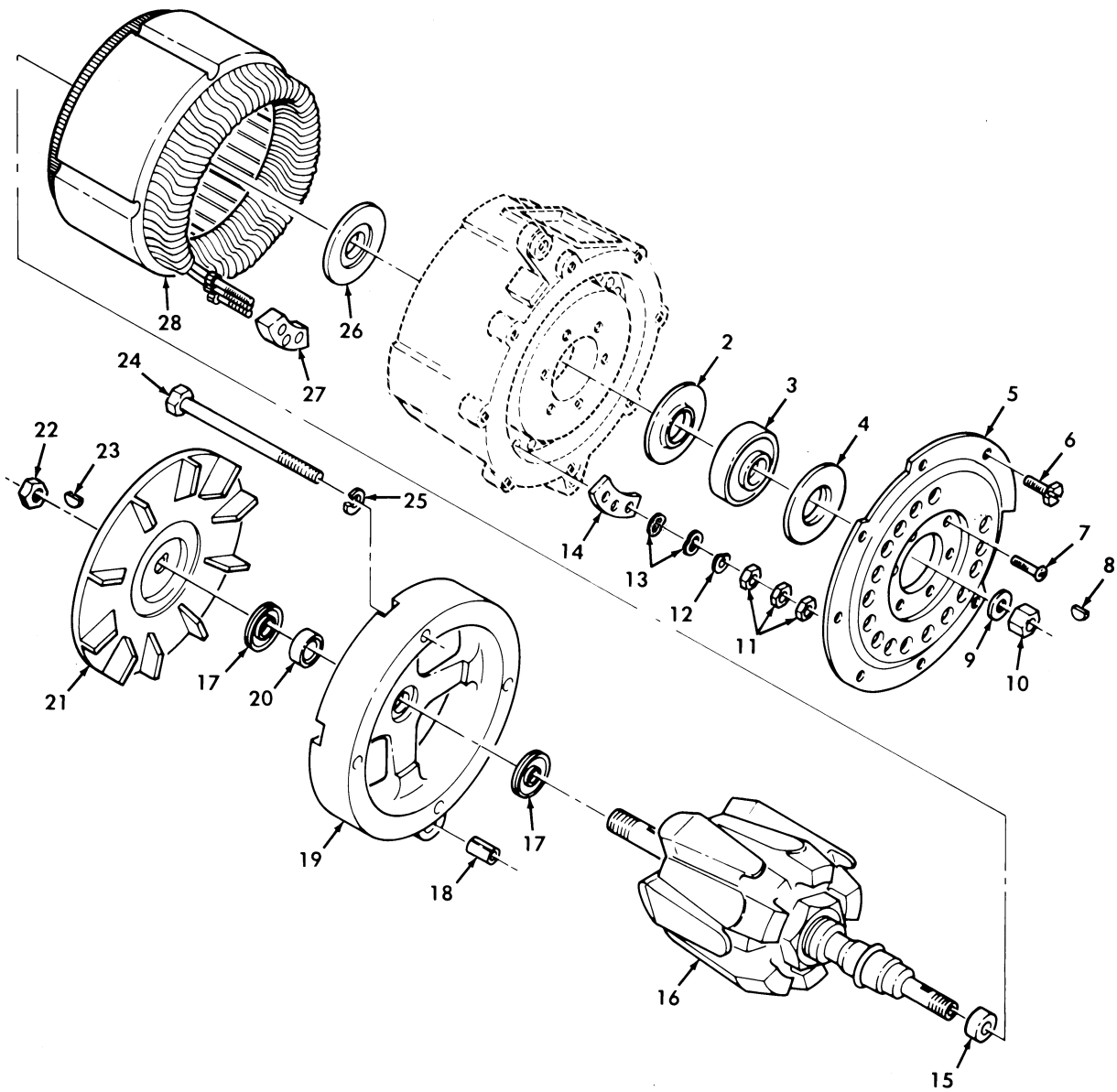

Figure 39. 200 Amp Alternator, M996, M996A1, M997, M997A1, M1097, and M1097A1 (PRESTOLITE) (Sheet 1 of 2).

USE WITH BASIC AND A1 VEHICLES

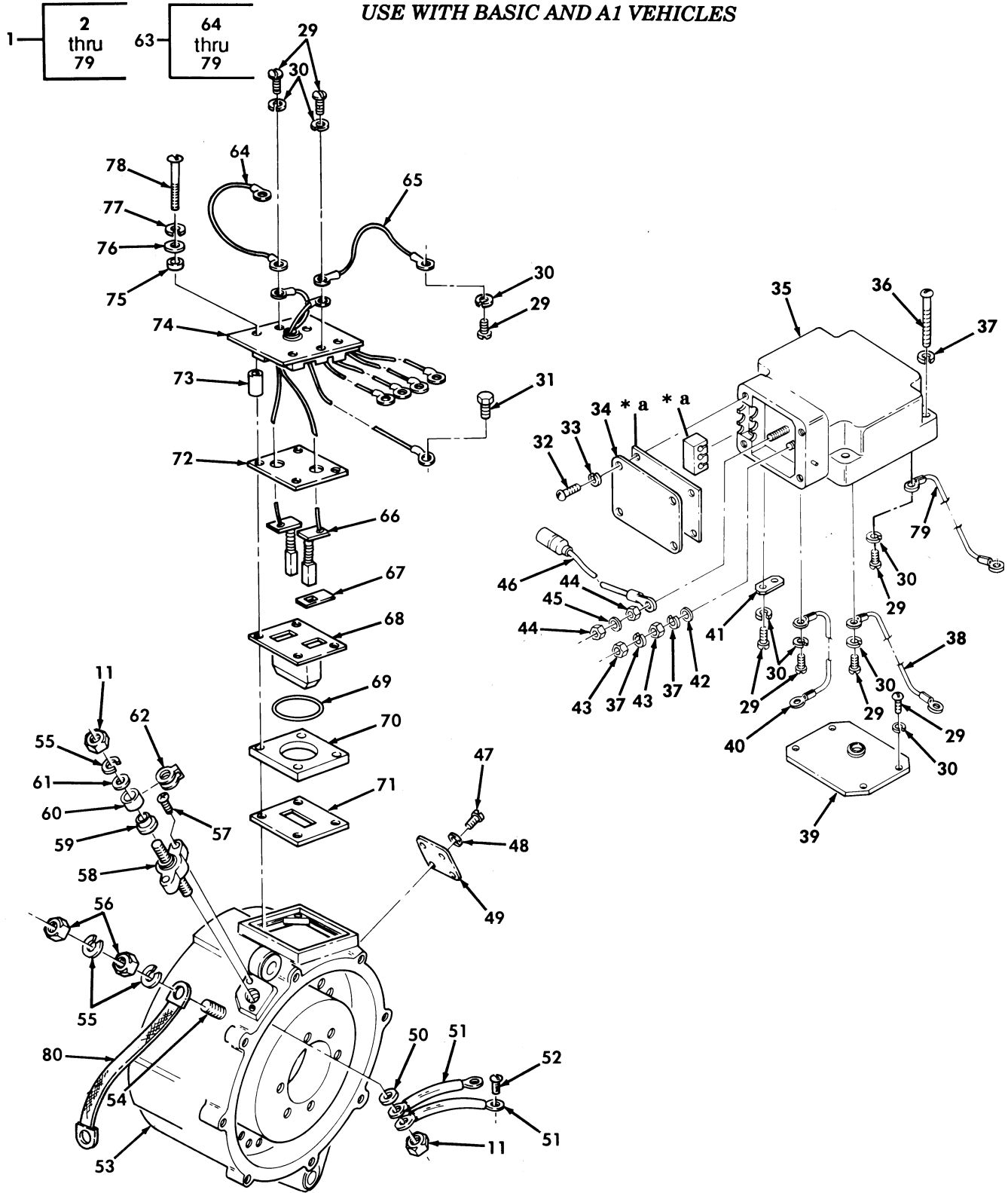

Figure 39. 200 Amp Alternator, M996, M996A1, M997, M997A1, M1097, and M1097A1 (PRESTOLITE) (Sheet 2 of 2).



SECTION II			TM9-2320-280-24P			
(1)	(2)	(3)	(4)	(5)	(6)	(7)
ITEM	SMR			PART		
NO	CODE	NSN	CAGEC	NUMBER	DESCRIPTION AND USABLE ON CODES(UC)	QTY
GROUP 0601 GENERATOR: ALTERNATOR						
FIG. 39 200 AMP ALTERNATOR, M996, M996A1, M997, M997A1, M1097, AND M1097A1 (PRESTOLITE)						
1	PAOFF	2920012646542	19207	12338796-1	GENERATOR, ENGINE AC 200 AMP.....	1
					UOC:AVY, A15, B16, HVY, H15, H16	
2	PAFZZ	5330012725474	35510	95513	.SEAL, PLAIN.....	1
					UOC:AVY, A15, B16, HVY, H15, H16	
3	PAFZZ	3130012716464	35510	95510	.BEARING UNIT, BALL.....	1
					UOC:AVY, A15, B16, HVY, H15, H16	
4	PAFZZ	5330012727454	24975	100276	.SEAL, PLAIN.....	1
					UOC:AVY, A15, B16, HVY, H15, H16	
5	PAFZZ	5340012725516	35510	95552	.COVER, ACCESS.....	1
					UOC:AVY, A15, B16, HVY, H15, H16	
6	PAFZZ	5305001804966	96906	MS51849-64	.SCREW, MACHINE #10-32 X .5.....	8
					UOC:AVY, A15, B16, HVY, H15, H16	
7	PAFZZ	5305006017729	35510	4465	.SCREW, MACHINE #10-32 X .5.....	6
					UOC:AVY, A15, B16, HVY, H15, H16	
8	PAOZZ	5315000124553	80205	MS35756-17	.KEY, WOODRUFF #15.....	1
					UOC:AVY, A15, B16, HVY, H15, H16	
9	PAOZZ	5310005956612	96906	MS20002-12	.WASHER, FLAT 3/4.....	1
					UOC:AVY, A15, B16, HVY, H15, H16	
10	PAOZZ	5310004190876	96906	MS21245-L12	.NUT, SELF-LOCKING, HE 3/4-16.....	1
					UOC:AVY, A15, B16, HVY, H15, H16	
11	PAFZZ	5310007610654	96906	MS51967-9	.NUT, PLAIN, HEXAGON 3/8-16.....	11
					UOC:AVY, A15, B16, HVY, H15, H16	
12	PAFZZ	5310001122233	08484	SP1548-1	.WASHER, FLAT 3/8.....	3
					UOC:AVY, A15, B16, HVY, H15, H16	
13	PAFZZ	5310012708377	35510	95605	.WASHER, FLAT 3/8.....	6
					UOC:AVY, A15, B16, HVY, H15, H16	
14	PAFZZ	5970012698384	35510	95467	.INSULATOR, PLATE.....	1
					UOC:AVY, A15, B16, HVY, H15, H16	
15	PAFZZ	5365012727502	35510	96745	.SPACER, SLEEVE.....	1
					UOC:AVY, A15, B16, HVY, H15, H16	
16	PAFZZ	2920013109978	35510	96520	.ROTOR ASSEMBLY.....	1
					UOC:AVY, A15, B16, HVY, H15, H16	
17	PAFZZ	5330012729071	35510	95483	.SEAL, PLAIN.....	2
					UOC:AVY, A15, B16, HVY, H15, H16	
18	PAFZZ	3120012702645	35510	77960	.BUSHING, SLEEVE.....	1
					UOC:AVY, A15, B16, HVY, H15, H16	
19	XAFZZ		35510	96846	.HOUSING ASSEMBLY.....	1
					UOC:AVY, A15, B16, HVY, H15, H16	
20	PAFZZ	3110012716355	35510	96764	.BEARING, ROLLER, TAPE.....	1
					UOC:AVY, A15, B16, HVY, H15, H16	
21	PAFZZ	6115012697911	35510	95972	.IMPELLER, FAN, CENTRI.....	1
					UOC:AVY, A15, B16, HVY, H15, H16	
22	PAFZZ	5310012708415	35510	74107	.NUT, SELF-LOCKING, CL 1/2-20.....	1
					UOC:AVY, A15, B16, HVY, H15, H16	
23	PAFZZ	5315012658771	35510	1869	.KEY, MACHINE #7.....	1
					UOC:AVY, A15, B16, HVY, H15, H16	
24	PAFZZ	5306012724798	35510	95469	.BOLT, MACHINE 5/16-18 X 5.00.....	4

SECTION II			TM9-2320-280-24P			
(1)	(2)	(3)	(4)	(5)	(6)	(7)
ITEM NO	SMR CODE	NSN	CAGEC	PART NUMBER	DESCRIPTION AND USABLE ON CODES(UOC)	QTY
25	PAFZZ	5310001711734	72452	1459-254	UOC:AVY,A15,B16,HVY,H15,H16 .WASHER,LOCK 5/16.....	5
26	PAFZZ	5330012703668	35510	95498	UOC:AVY,A15,B16,HVY,H15,H16 .GASKET.....	1
27	PAFZZ	5970012701465	35510	96259	UOC:AVY,A15,B16,HVY,H15,H16 .INSULATOR,TERMINAL.....	1
28	PAFZZ	2920013109973	35510	A022096282	UOC:AVY,A15,B16,HVY,H15,H16 .STATOR,ENGINE GENER.....	1
29	PAFZZ	5930007363539	13445	5582	UOC:AVY,A15,B16,HVY,H15,H16 .SWITCH,TOGGLE #6-32 X 5/16.....	16
30	PAFZZ	5310000454007	96906	MS35338-41	UOC:AVY,A15,B16,HVY,H15,H16 .WASHER,LOCK #6 STEEL.....	12
31	PAFZZ	5305012822667	35510	95504	UOC:AVY,A15,B16,HVY,H15,H16 .SCREW,CAP,HEXAGON H 5/16-18 X 1/2.	1
32	PAOZZ	5305009896265	96906	MS35207-262	UOC:AVY,A15,B16,HVY,H15,H16 .SCREW,MACHINE #10-32.....	2
33	PAOZZ	5310000453296	96906	MS35338-43	UOC:AVY,A15,B16,HVY,H15,H16 .WASHER,LOCK #10.....	2
34	PFOZZ	5340012722677	35510	100212	UOC:AVY,A15,B16,HVY,H15,H16 .COVER,ACCESS.....	1
35	XAOZZ		35510	R027100150	UOC:AVY,A15,B16,HVY,H15,H16 .REGULATOR,ENGINE GE.....	1
36	PAFZZ	5305012729024	35510	2879	UOC:AVY,A15,B16,HVY,H15,H16 .SCREW,MACHINE #10-32 X 1-1/4.....	4
37	PAFZZ	5310007755139	35510	2434	UOC:AVY,A15,B16,HVY,H15,H16 .WASHER,LOCK #10.....	6
38	PAFZZ	6150012691855	35510	96154	UOC:AVY,A15,B16,HVY,H15,H16 .LEAD,ELECTRICAL RED.....	1
39	XBFZZ		35510	96247	UOC:AVY,A15,B16,HVY,H15,H16 .PLATE,MENDING.....	1
40	PAFZZ	6150012691856	35510	96160	UOC:AVY,A15,B16,HVY,H15,H16 .LEAD,ELECTRICAL BLACK.....	1
41	PAFZZ	3040012713823	35510	96377	UOC:AVY,A15,B16,HVY,H15,H16 .CONNECTING LINK,RIG.....	1
42	PAOZZ	5310004293453	35510	75451	UOC:AVY,A15,B16,HVY,H15,H16 .WASHER,FLAT #10.....	1
43	PAOZZ	5310004293135	35510	4340	UOC:AVY,A15,B16,HVY,H15,H16 .NUT,PLAIN,HEXAGON #10-32.....	2
44	PAOZZ	5310004293156	35510	59982S	UOC:AVY,A15,B16,HVY,H15,H16 .NUT TERMINAL 1/4-20.....	2
45	PAOZZ	5310011431679	35510	Z0982-75723	UOC:AVY,A15,B16,HVY,H15,H16 .WASHER,FLAT.....	2
46	PAOZZ	6150012691857	35510	100204	UOC:AVY,A15,B16,HVY,H15,H16 .LEAD,ELECTRICAL.....	1
47	PAFZZ	5305012729025	35510	13981	UOC:AVY,A15,B16,HVY,H15,H16 .SCREW,MACHINE #4-40 X 5/16.....	4
48	PAFZZ	5310012724831	35510	7266	UOC:AVY,A15,B16,HVY,H15,H16 .WASHER,LOCK #4.....	4
49	PFFZZ	5340012708484	35510	100210	UOC:AVY,A15,B16,HVY,H15,H16 .COVER,ACCESS.....	1
50	PAOZZ	5365012724877	35510	96180	UOC:AVY,A15,B16,HVY,H15,H16 .SPACER,SLEEVE.....	1

SECTION II			TM9-2320-280-24P			
(1)	(2)	(3)	(4)	(5)	(6)	(7)
ITEM	SMR			PART		
NO	CODE	NSN	CAGEC	NUMBER	DESCRIPTION AND USABLE ON CODES(UC)	QTY
51	PAFZZ	6150012691863	35510	96162	.LEAD ASSEMBLY,ELECT..... UOC:AVY,A15,B16,HVY,H15,H16	2
52	PAFZZ	5305011475864	35510	Z116095517	.SCREW,CAP,HEXAGON H 5/16-18 X 1/2. UOC:AVY,A15,B16,HVY,H15,H16	2
53	PAFZZ	6130013096458	35510	96756	.RECTIFIER,METALLIC..... UOC:AVY,A15,B16,HVY,H15,H16	1
54	PAFZZ	5307012727539	35510	95484	.STUD,PLAIN..... UOC:AVY,A15,B16,HVY,H15,H16	1
55	PAOZZ	5310012100819	35510	26351	.WASHER,LOCK 5/16..... UOC:AVY,A15,B16,HVY,H15,H16	3
56	PAOZZ	5310012806751	96906	MS35692-53	.NUT,PLAIN,SLOTTED,H 1/4..... UOC:AVY,A15,B16,HVY,H15,H16	2
57	PAFZZ	5305007772284	35510	Z106005179	.SCREW,MACHINE #10-32 X 1/2..... UOC:AVY,A15,B16,HVY,H15,H16	2
58	PAFZZ	5920012758096	35510	Z116 096169	.FUSEHOLDER,EXTRACTO..... UOC:AVY,A15,B16,HVY,H15,H16	1
59	PAOZZ	3120012716432	35510	96171	.BUSHING,SLEEVE..... UOC:AVY,A15,B16,HVY,H15,H16	1
60	PAOZZ	5970012701467	35510	96187	.INSULATOR,FUSE..... UOC:AVY,A15,B16,HVY,H15,H16	1
61	PAOZZ	5310012711841	35510	5295	.WASHER,FLAT 3/8..... UOC:AVY,A15,B16,HVY,H15,H16	1
62	PAOZZ	5920012663908	35510	96188	.FUSE,CARTRIDGE..... UOC:AVY,A15,B16,HVY,H15,H16	1
63	PAFFF	5977014072847	35510	A777100841	.HOLDER,ELECTRICAL C..... UOC:AVY,A15,B16,HVY,H15,H16	1
64	PAFZZ	6150012691858	35510	96156	..LEAD,ELECTRICAL..... UOC:AVY,A15,B16,HVY,H15,H16	1
65	PAFZZ	6150012691854	35510	96158	..LEAD,ELECTRICAL RED..... UOC:AVY,A15,B16,HVY,H15,H16	1
66	PAFZZ	5977012701466	24975	A010095461	..BRUSH,ELECTRICAL CO..... UOC:AVY,A15,B16,HVY,H15,H16	2
67	PAFZZ	5330012708316	35510	96172	..GASKET..... UOC:AVY,A15,B16,HVY,H15,H16	2
68	PAFZZ	5977011436996	35510	99479	..HOLDER,ELECTRICAL C..... UOC:AVY,A15,B16,HVY,H15,H16	1
69	PAFZZ	5330011455376	35510	99514	..PACKING,PREFORMED..... UOC:AVY,A15,B16,HVY,H15,H16	1
70	PAFZZ	5340012736944	35510	96769	..PLATE,RETAINING,SEA..... UOC:AVY,A15,B16,HVY,H15,H16	1
71	PAFZZ	5330012728337	35510	96768	..GASKET..... UOC:AVY,A15,B16,HVY,H15,H16	1
72	PAFZZ	5977012701468	24975	95515	..COVER,BRUSH..... UOC:AVY,A15,B16,HVY,H15,H16	1
73	PAFZZ	5365012722663	35510	95516	..SPACER,SLEEVE..... UOC:AVY,A15,B16,HVY,H15,H16	4
74	PAFZZ	5998011477895	35510	R055101472	..CIRCUIT CARD ASSEMB DIODE TRIO... UOC:AVY,A15,B16,HVY,H15,H16	1
75	PAFZZ	5970012609132	35510	95965	..INSULATOR,WASHER #8..... UOC:AVY,A15,B16,HVY,H15,H16	4
76	PAFZZ	5310011431679	35510	36912	..WASHER,FLAT #8..... UOC:AVY,A15,B16,HVY,H15,H16	4
77	PAFZZ	5310000453299	35510	36895	..WASHER,LOCK #8.....	4

SECTION II			TM9-2320-280-24P			
(1)	(2)	(3)	(4)	(5)	(6)	(7)
ITEM	SMR			PART		
NO	CODE	NSN	CAGEC	NUMBER	DESCRIPTION AND USABLE ON CODES(UC)	QTY
78	PAFZZ	5305012728302	35510	23304	UOC:AVY,A15,B16,HVY,H15,H16 ..SCREW,MACHINE #8-32 X 1-3/4.....	4
79	PAFZZ	6150013353087	35510	100209	UOC:AVY,A15,B16,HVY,H15,H16 ..LEAD,ELECTRICAL BLACK,#11.....	1
80	PAOZZ	5999013725601	19207	12341151	UOC:AVY,A15,B16,HVY,H15,H16 STRIP,ELECTRICAL GR.....	1

END OF FIGURE

Section II.

TM 9-2320-280-24P-1

1 — 2  
thru  
51

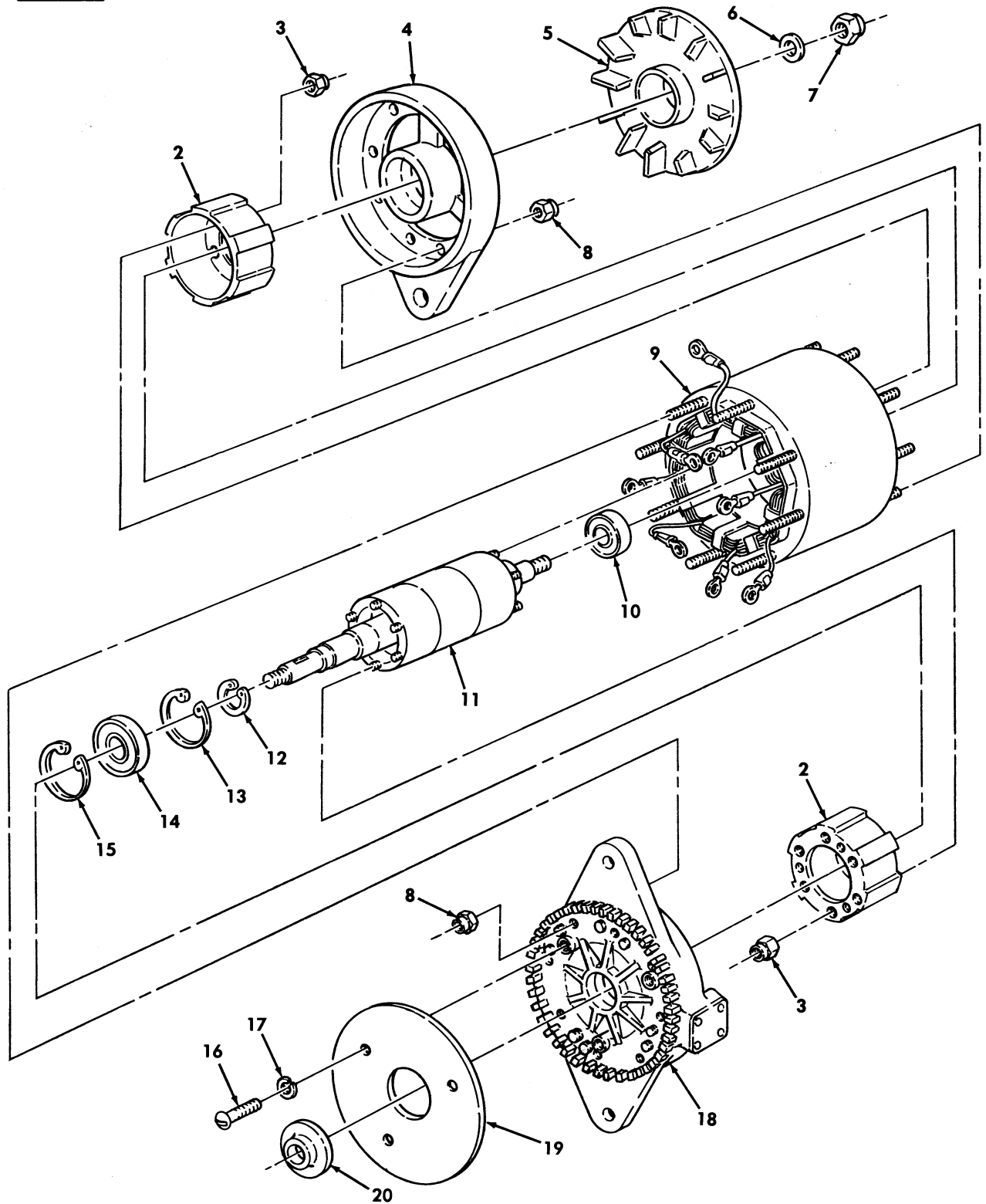
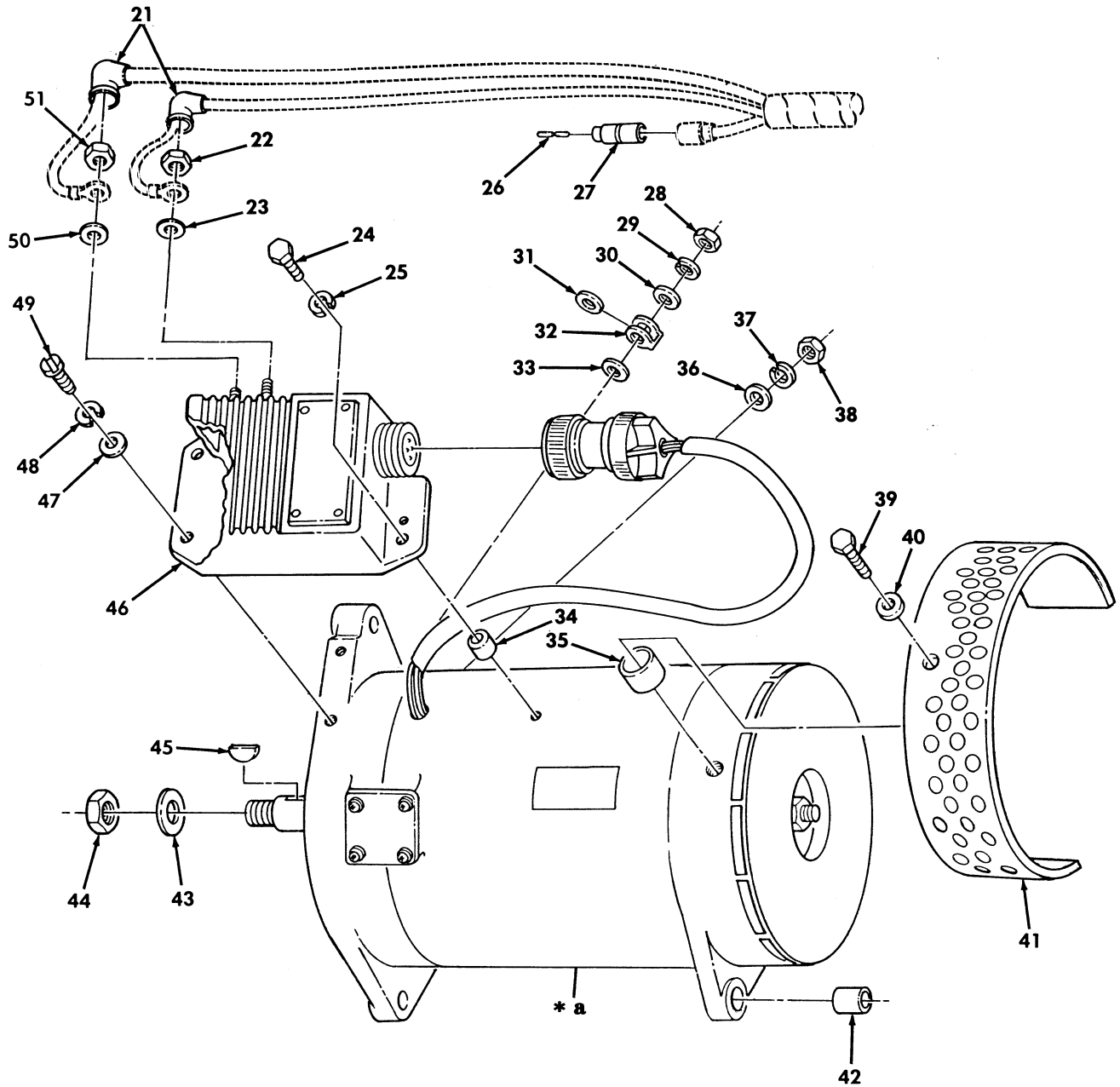

Figure 40. 200 AMP Alternator, M996, M996A1, M997, M997A1, M997A2, M1097, M1097A1, M1097A2, and M1123 (NIEHOFF) (Sheet 1 of 2).

1  
2  
thru  
51



\* a PART OF ITEM 1

Figure 40. 200 AMP Alternator, M996, M996A1, M997, M997A1, M997A2, M1097, M1097A1, M1097A2, and M1123 (NIEHOFF) (Sheet 2 of 2).

SECTION II			TM9-2320-280-24P			
(1)	(2)	(3)	(4)	(5)	(6)	(7)
ITEM NO	SMR CODE	NSN	CAGEC	PART NUMBER	DESCRIPTION AND USABLE ON CODES(UC)	QTY
					GROUP 0601 GENERATOR: ALTERNATOR	
					FIG. 40 200 AMP ALTERNATOR, M996, M996A1, M997, M997A1, M997A2, M1097, M1097A1, M1097A2, AND M1123 (NIEHOFF)	
1	PAOFF	2920014209968	19207	12447109	GENERATOR, ENGINE AC.....	1
					UOC:AVY, A15, BVY, B15, B16, HVY, H15, H16, NNN	
2	PAFZZ	2920013635173	76761	N7312	.ROTOR ASSEMBLY.....	2
					UOC:AVY, A15, BVY, B15, B16, HVY, H15, H16, NNN	
3	PAFZZ	5310012250701	76761	N9098	.NUT.....	9
					UOC:AVY, A15, BVY, B15, B16, HVY, H15, H16, NNN	
4	XAFZZ		76761	N9452	.HOUSING ASSEMBLY.....	1
					UOC:AVY, A15, BVY, B15, B16, HVY, H15, H16, NNN	
5	PFFZZ	6115013495320	76761	N7309	.IMPELLER, FAN, CENTRI.....	1
					UOC:AVY, A15, BVY, B15, B16, HVY, H15, H16, NNN	
6	PAFZZ	5310010506565	76761	N9063	.WASHER, FLAT.....	1
					UOC:AVY, A15, BVY, B15, B16, HVY, H15, H16, NNN	
7	PAFZZ	5310000443340	19207	8712289	.NUT, SELF-LOCKING, HE.....	1
					UOC:AVY, A15, BVY, B15, B16, HVY, H15, H16, NNN	
8	PAFZZ	5310011651312	82458	TLNF-0832-S	.NUT, SELF-LOCKING, EX.....	18
					UOC:AVY, A15, BVY, B15, B16, HVY, H15, H16, NNN	
9	XAFZZ		76761	N7346	.SHELL AND STATOR.....	1
					UOC:AVY, A15, BVY, B15, B16, HVY, H15, H16, NNN	
10	PAFZZ	3110013484867	76761	N9385	.BEARING, BALL, ANNULA.....	1
					UOC:AVY, A15, BVY, B15, B16, HVY, H15, H16, NNN	
11	XAFZZ		76761	N7347	.CORE AND SHAFT.....	1
					UOC:AVY, A15, BVY, B15, B16, HVY, H15, H16, NNN	
12	PAFZZ	5325011367662	76761	N9260	.RING, RETAINING.....	1
					UOC:AVY, A15, BVY, B15, B16, HVY, H15, H16, NNN	
13	PAFZZ	5325010324222	76761	N9008	.RING, RETAINING.....	1
					UOC:AVY, A15, BVY, B15, B16, HVY, H15, H16, NNN	
14	PAFZZ	3110010374661	76761	N9010	.BEARING, BALL, ANNULA.....	1
					UOC:AVY, A15, BVY, B15, B16, HVY, H15, H16, NNN	
15	PAFZZ	5325010342757	76761	N9009	.RING, RETAINING.....	1
					UOC:AVY, A15, BVY, B15, B16, HVY, H15, H16, NNN	
16	PAFZZ	5305010324165	76761	N9005	.SCREW, MACHINE.....	3
					UOC:AVY, A15, BVY, B15, B16, HVY, H15, H16, NNN	

SECTION II			TM9-2320-280-24P			
(1)	(2)	(3)	(4)	(5)	(6)	(7)
ITEM NO	SMR CODE	NSN	CAGEC	PART NUMBER	DESCRIPTION AND USABLE ON CODES(UC)	QTY
17	PAFZZ	5310011364888	76761	N9265	.WASHER, LOCK..... UC:AVY, A15, BVY, B15, B16, HVY, H15, H16, NNN	3
18	XAFZZ		76761	N7348	.HOUSING ASSEMBLY FRONT..... UC:AVY, A15, B16, HVY, H15, H16	1
18	XAFZZ		76761	N7434	.HOUSING ASSEMBLY..... UC:BVY, B15, NNN	1
19	PFFZZ	5999013480302	76761	N9318	.PLATE, ELECTRICAL SH..... UC:AVY, A15, B16, HVY, H15, H16	1
19	PFFZZ	2920014753180	76761	N9502	.COVER, ELECTRICAL GE..... UC:BVY, B15, NNN	1
20	PAOZZ	3120013483364	76761	N9417	.BUSHING, SLEEVE..... UC:AVY, A15, BVY, B15, B16, HVY, H15, H16, NNN	1
21	PAOZZ	5975013501987	76761	N9464	.BOOT, DUST AND MOIST..... UC:AVY, A15, BVY, B15, B16, HVY, H15, H16, NNN	2
22	PAOZZ	5310013504257	76761	N9467	.NUT, PLAIN, CAP..... UC:AVY, A15, BVY, B15, B16, HVY, H15, H16, NNN	1
23	PAOZZ	5310013508549	76761	N9465	.WASHER, FLAT..... UC:AVY, A15, BVY, B15, B16, HVY, H15, H16, NNN	1
24	PAOZZ	5306013488310	76761	N9457	.BOLT, MACHINE..... UC:AVY, A15, BVY, B15, B16, HVY, H15, H16, NNN	1
25	PAOZZ	5310013488393	76761	N9459	.WASHER, LOCK..... UC:AVY, A15, BVY, B15, B16, HVY, H15, H16, NNN	1
26	PAOZZ	5935002140904	19207	7982907	.DUMMY CONNECTOR, PLU..... UC:AVY, A15, BVY, B15, B16, HVY, H15, H16, NNN	1
27	PAOZZ	5975013580021	76761	N9500	.CABLE NIPPLE, ELECTR..... UC:AVY, A15, BVY, B15, B16, HVY, H15, H16, NNN	1
28	PAOZZ	5310013488314	76761	N9453	.NUT, PLAIN, HEXAGON..... UC:AVY, A15, BVY, B15, B16, HVY, H15, H16, NNN	1
29	PAOZZ	5310013488392	76761	N9461	.WASHER, LOCK..... UC:AVY, A15, BVY, B15, B16, HVY, H15, H16, NNN	1
30	PAOZZ	5310012321361	76761	N9331	.WASHER, FLAT..... UC:AVY, A15, BVY, B15, B16, HVY, H15, H16, NNN	1
31	PAOZZ	5970013505646	76761	N9420	.INSULATOR, WASHER..... UC:AVY, A15, BVY, B15, B16, HVY, H15, H16, NNN	1
32	PAOZZ	5920013480303	76761	N9414	.FUSE LINK, ELECTRICA..... UC:AVY, A15, BVY, B15, B16, HVY, H15, H16, NNN	1
33	PAOZZ	5310013488386	76761	N9408	.WASHER, FLAT..... UC:AVY, A15, BVY, B15, B16, HVY, H15, H16, NNN	1







SECTION II			TM9-2320-280-24P			
(1)	(2)	(3)	(4)	(5)	(6)	(7)
ITEM NO	SMR CODE	NSN	CAGEC	PART NUMBER	DESCRIPTION AND USABLE ON CODES(UCO)	QTY
34	PAOZZ	5365013486971	76761	N9460	. SPACER, SLEEVE..... UCO:AVY, A15, BVY, B15, B16, HVY, H15, H16, NNN	1
35	PAOZZ	5365012250844	76761	N9269	. SPACER, SLEEVE..... UCO:AVY, A15, BVY, B15, B16, HVY, H15, H16, NNN	3
36	PAOZZ	5310013488385	76761	N9455	. WASHER, FLAT..... UCO:AVY, A15, BVY, B15, B16, HVY, H15, H16, NNN	1
37	PAOZZ	5310010460186	76761	N9015	. WASHER, LOCK..... UCO:AVY, A15, BVY, B15, B16, HVY, H15, H16, NNN	1
38	PAOZZ	5310013488313	76761	N9426	. NUT, PLAIN, HEXAGON..... UCO:AVY, A15, BVY, B15, B16, HVY, H15, H16, NNN	1
39	PAOZZ	5306012234345	76761	N9077	. BOLT, SELF-LOCKING..... UCO:AVY, A15, BVY, B15, B16, HVY, H15, H16, NNN	3
40	PAOZZ	5310012321362	76761	N9338	. WASHER, FLAT..... UCO:AVY, A15, BVY, B15, B16, HVY, H15, H16, NNN	3
41	PFOZZ	4140013500839	76761	N7370	. GUARD, FAN IMPELLER..... UCO:AVY, A15, BVY, B15, B16, HVY, H15, H16, NNN	1
42	PAOZZ	3120014136106	19207	12342711	. BUSHING, SLEEVE..... UCO:AVY, A15, BVY, B15, B16, HVY, H15, H16, NNN	1
43	PAOZZ	5310013488384	76761	N9393	. WASHER, FLAT..... UCO:AVY, A15, BVY, B15, B16, HVY, H15, H16, NNN	1
44	PAOZZ	5310013488360	76761	N9416	. NUT, SELF-LOCKING, HE..... UCO:AVY, A15, BVY, B15, B16, HVY, H15, H16, NNN	1
45	PAOZZ	5315013486880	76761	N9451	. KEY, WOODRUFF..... UCO:AVY, A15, BVY, B15, B16, HVY, H15, H16, NNN	1
46	PAOZZ	2920013481526	76761	N3106	. REGULATOR, ENGINE GE..... UCO:AVY, A15, B16, HVY, H15, H16, NNN	1
46	PAOZZ	2920014159497	76761	N-3117	. REGULATOR, ENGINE GE..... UCO:BVY, B15, NNN	1
47	PAOZZ	5310010324169	76761	N9016	. WASHER, FLAT..... UCO:AVY, A15, BVY, B15, B16, HVY, H15, H16, NNN	2
48	PAOZZ	5310010324827	76761	N9018	. WASHER, SPRING TENSI..... UCO:AVY, A15, BVY, B15, B16, HVY, H15, H16, NNN	2
49	PAOZZ	5305004427347	80205	NAS1635-3-12P	. SCREW, MACHINE..... UCO:AVY, A15, BVY, B15, B16, HVY, H15, H16, NNN	2
50	PAOZZ	5310010428391	13499	500-1114-003	. WASHER, FLAT..... UCO:AVY, A15, BVY, B15, B16, HVY, H15, H16, NNN	1
51	PAOZZ	5310013488398	76761	N9410	. NUT, PLAIN, OCTAGON.....	1

SECTION II			TM9-2320-280-24P			
(1)	(2)	(3)	(4)	(5)	(6)	(7)
ITEM	SMR			PART		
NO	CODE	NSN	CAGEC	NUMBER	DESCRIPTION AND USABLE ON CODES (UOC)	QTY

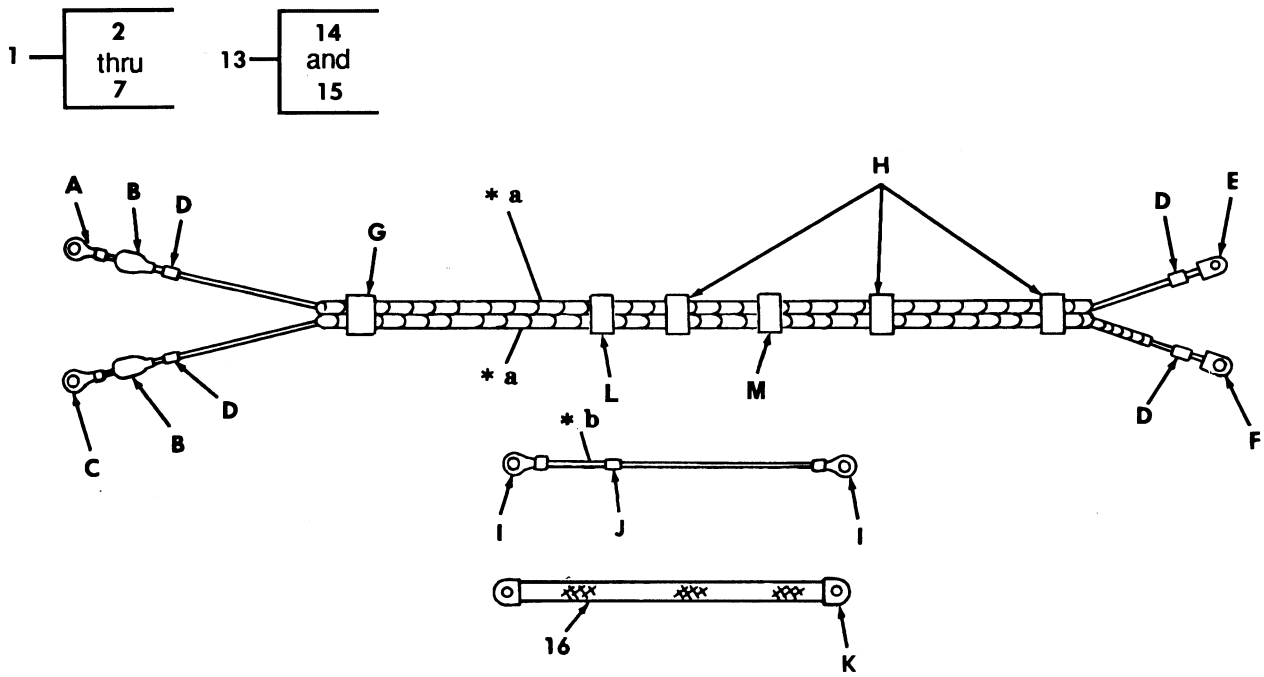
UOC:AVY,A15,BVY,B15,B16,HVY,H15,H16,  
 NNN

END OF FIGURE

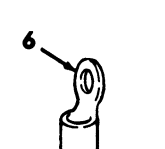
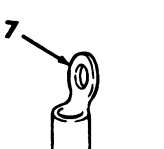
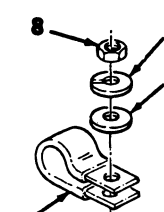
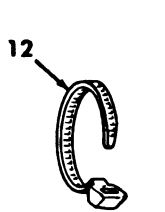
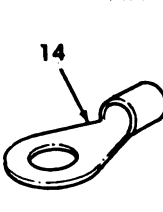
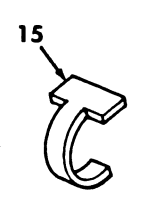
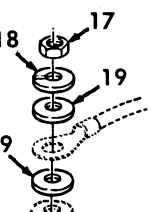
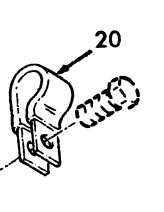
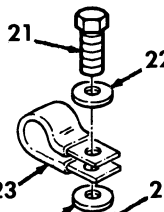

 <p><b>VIEW A</b></p>	 <p><b>VIEW B</b></p>	 <p><b>VIEW C</b></p>	 <p><b>VIEW D</b></p>	 <p><b>VIEW E</b></p>	 <p><b>VIEW F</b></p>
 <p><b>VIEW G</b></p>	 <p><b>VIEW H</b></p>	 <p><b>VIEW I</b></p>	 <p><b>VIEW J</b></p>	 <p><b>VIEW K</b></p>	 <p><b>VIEW L</b></p>
 <p><b>VIEW M</b></p>					

- \* a PART OF ITEM 1
- \* b PART OF ITEM 13

Figure 41. A2 Alternator Wiring Harness.

SECTION II			TM9-2320-280-24P			
(1)	(2)	(3)	(4)	(5)	(6)	(7)
ITEM NO	SMR CODE	NSN	CAGEC	PART NUMBER	DESCRIPTION AND USABLE ON CODES(UC)	QTY
GROUP 0601 GENERATOR: ALTERNATOR						
FIG. 41 A2 ALTERNATOR WIRING HARNESS						
1	MOOZZ		19207	12446821-5	CABLE AND CONDUIT A POSITIVE,MAKE FROM WIRE,P/N M13486/1-9,102 INCHES LONG.....	1
					UC:BVY,B15,B20,B24,B25,C17,NNN	
1	MOOZZ		19207	12446821-2	CABLE AND CONDUIT A NEGITIVE,MAKE FROM WIRE,P/N M13486/1-11,103 INCHES LONG.....	1
					UC:BVY,B15,B20,B24,B25,C17,NNN	
2	PAOZZ	5940001152674	96906	MS20659-108	. TERMINAL, LUG.....	1
					UC:BVY,B15,B20,B24,B25,C17,NNN	
3	PAOZZ	5340014742315	7Z043	224N2V14	. BOOT, DUST AND MOIST.....	2
					UC:BVY,B15,B20,B24,B25,C17,NNN	
4	PAOZZ	5940011704956	19207	8689221	. TERMINAL, LUG.....	1
					UC:BVY,B15,B20,B24,B25,C17,NNN	
5	PAOZZ	9905008933570	81349	M43436/1-3	. BAND, MARKER.....	4
					UC:BVY,B15,B20,B24,B25,C17,NNN	
6	PAOZZ	5940001141314	96906	MS20659-129	. TERMINAL, LUG.....	1
					UC:BVY,B15,B20,B24,B25,C17,NNN	
7	PAOZZ	5940001152678	96906	MS20659-111	. TERMINAL, LUG.....	1
					UC:BVY,B15,B20,B24,B25,C17,NNN	
8	PAOZZ	5310013958747	80204	B18241B100F	NUT, PLAIN, HEXAGON 1/4-28.....	1
					UC:BVY,B15,B20,B24,B25,C17,NNN	
9	PAFZZ	5310012067306	7X677	11500207	WASHER, LOCK M10.....	1
					UC:BVY,B15,B20,B24,B25,C17,NNN	
10	PAFZZ	5310012101587	7X677	11500256	WASHER, FLAT 10MM.....	1
					UC:BVY,B15,B20,B24,B25,C17,NNN	
11	PAFZZ	5340007022848	96906	MS21333-128	CLAMP, LOOP.....	1
					UC:BVY,B15,B20,B24,B25,C17,NNN	
12	PAOZZ	5975005709598	96906	MS3367-7-9	STRAP, TIEDOWN, ELECT.....	3
					UC:BVY,B15,B20,B24,B25,C17,NNN	
13	MOOZZ		19207	12446821-1	CABLE ASSEMBLY NEGATIVE,MAKE FROM WIRE,P/N M13486/1-11,11.75 INCHES LONG.....	1
					UC:BVY,B15,B20,B24,B25,C17,NNN	
14	PAOZZ	5940011704956	19207	8689221	. TERMINAL, LUG.....	2
					UC:BVY,B15,B20,B24,B25,C17,NNN	
15	PAOZZ	9905008933570	81349	M43436/1-3	. BAND, MARKER.....	1
					UC:BVY,B15,B20,B24,B25,C17,NNN	
16	PAOZZ	5999013725601	19207	12341151	STRIP, ELECTRICAL GR.....	1
					UC:BVY,B15,B20,B24,B25,C17,NNN	
17	PAOZZ	5310013958747	80204	B18241B100F	NUT, PLAIN, HEXAGON M10.....	1
					UC:BVY,B15,B20,B24,B25,C17,NNN	
18	PAOZZ	5310012067306	7X677	11500207	WASHER, LOCK M10.....	1
					UC:BVY,B15,B20,B24,B25,C17,NNN	
19	PAOZZ	5310012101587	7X677	11500256	WASHER, FLAT.....	2
					UC:BVY,B15,B20,B24,B25,C17,NNN	
20	PAOZZ	5340009226301	96906	MS21333-79	CLAMP, LOOP.....	1
					UC:BVY,B15,B20,B24,B25,C17,NNN	
21	PAOZZ	5306002264827	80204	B1821BH031C100N	BOLT, MACHINE.....	1

SECTION II			TM9-2320-280-24P			
(1)	(2)	(3)	(4)	(5)	(6)	(7)
ITEM	SMR			PART		
NO	CODE	NSN	CAGEC	NUMBER	DESCRIPTION AND USABLE ON CODES(UC)	QTY
22	PAOZZ	5310000814219	44940	526-1115	UOC:BVY,B15,NNN WASHER,FLAT.....	1
23	PAOZZ	5340001519651	96906	MS21333-129	UOC:BVY,B15,NNN CLAMP,LOOP.....	1
24	PAOZZ	5310004079566	96906	MS35338-45	UOC:BVY,B15,NNN WASHER,LOCK.....	1
25	PAOZZ	5310009318167	96906	MS51967-6	UOC:BVY,B15,NNN NUT,PLAIN,HEXAGON..... UOC:BVY,B15,NNN	1

END OF FIGURE

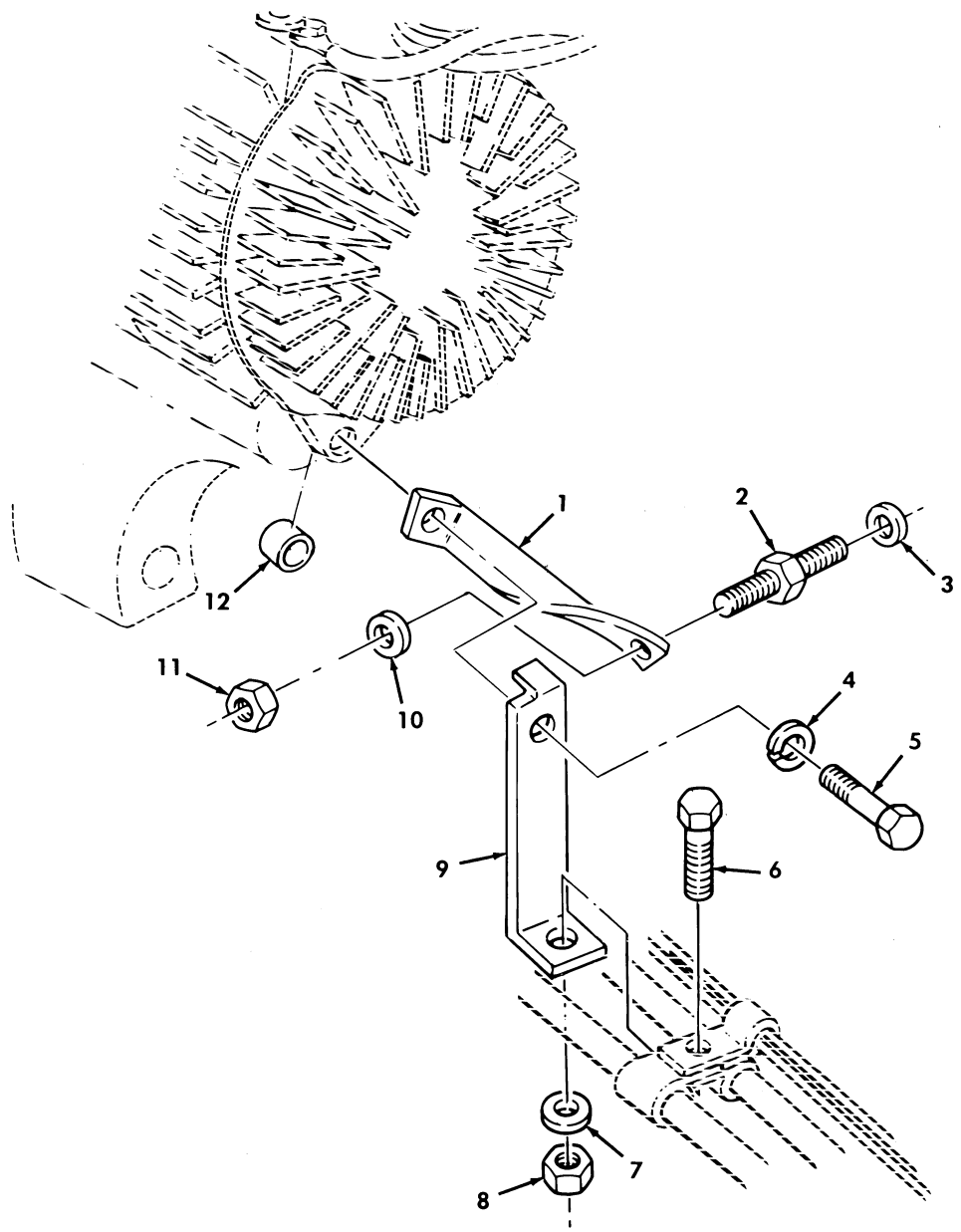

Figure 42. Kit, 60, 100, and 200 AMP Alternator Mounting Hardware.

SECTION II			TM9-2320-280-24P			
(1)	(2)	(3)	(4)	(5)	(6)	(7)
ITEM NO	SMR CODE	NSN	CAGEC	PART NUMBER	DESCRIPTION AND USABLE ON CODES(UOC)	QTY
GROUP 0601 GENERATOR: ALTERNATOR						
FIG. 42 KIT,60,100,AND 200 AMP ALTERNATOR MOUNTING HARDWARE						
1	PAOZZ	5340012930125	34623	5935091	BRACKET,MOUNTING PART OF KIT P/N 57K0109..... UOC:H11,H13,H14,H17,H18,H20,H21,H24,H25,H26,H27,H28,MMM	1
1	PAOZZ	5340012928404	34623	5935092	BRACKET,MOUNTING PART OF KIT P/N 5742041..... UOC:H15,H16	1
2	PAOZZ	5307013153597	19207	12339406-3	STUD,SHOULDERED PART OF KIT P/N 57K0109 PART OF KIT P/N 5742041..... UOC:H11,H13,H14,H15,H16,H17,H18,H20,H21,H24,H25,H26,H27,H28,MMM	1
3	PAOZZ	5310012510747	34623	5593260	WASHER,FLAT 10 MM PART OF KIT P/N 57K0109 PART OF KIT P/N 5742041..... UOC:H11,H13,H14,H15,H16,H17,H18,H20,H21,H24,H25,H26,H27,H28,MMM	1
4	PAOZZ	5310002090965	96906	MS35338-47	WASHER,LOCK 7/16 PART OF KIT P/N 57K0109 PART OF KIT P/N 5742041..... UOC:H11,H13,H14,H15,H16,H17,H18,H20,H21,H24,H25,H26,H27,H28,MMM	1
5	PAOZZ	5305000712059	80204	B1821BH044C250N	SCREW,CAP,HEXAGON H 7/16-14 X 2.50 PART OF KIT P/N 5742041..... UOC:H15,H16	1
5	PAOZZ	5305000712057	80204	B1821BH044C200N	SCREW,CAP,HEXAGON H 7/16-14 X 2.00 PART OF KIT P/N 57K0109..... UOC:H11,H13,H14,H17,H18,H20,H21,H24,H25,H26,H27,H28,MMM	1
6	PAOZZ	5305002253843	80204	B1821BH025C100N	SCREW,CAP,HEXAGON H 1/4-20 X 1.00 PART OF KIT P/N 57K0109 PART OF KIT P/N 5742041..... UOC:H11,H13,H14,H15,H16,H17,H18,H20,H21,H24,H25,H26,H27,H28,MMM	1
7	PAOZZ	5310008094058	89326	A22506-4	WASHER,FLAT 1/4 PART OF KIT P/N 57K0109 PART OF KIT P/N 5742041..... UOC:H11,H13,H14,H15,H16,H17,H18,H20,H21,H24,H25,H26,H27,H28,MMM	1
8	PAOZZ	5310000614650	96906	MS51943-31	NUT,SELF-LOCKING,HE 1/4-20 PART OF KIT P/N 57K0109 PART OF KIT P/N 5742041..... UOC:H11,H13,H14,H15,H16,H17,H18,H20,H21,H24,H25,H26,H27,H28,MMM	1
9	PAOZZ	5340012925402	34623	5935093	BRACKET,DOUBLE ANGL PART OF KIT P/N 57K0109 PART OF KIT P/N 5742041..... UOC:H11,H13,H14,H15,H16,H17,H18,H20,H21,H24,H25,H26,H27,H28,MMM	1
10	PAOZZ	5310012067306	7X677	11500207	WASHER,LOCK 10 MM PART OF KIT P/N 57K0109 PART OF KIT P/N 5742041..... UOC:H11,H13,H14,H15,H16,H17,H18,H20,H21,H24,H25,H26,H27,H28,MMM	1

SECTION II			TM9-2320-280-24P			
(1)	(2)	(3)	(4)	(5)	(6)	(7)
ITEM	SMR			PART		
NO	CODE	NSN	CAGEC	NUMBER	DESCRIPTION AND USABLE ON CODES(UC)	QTY
11	PAOZZ	5310013663539	80204	B18241B100F	NUT,PLAIN,HEXAGON 10MM X 1.5 PART OF KIT P/N 57K0109 PART OF KIT P/N 5742041.....	1
					UOC:H11,H13,H14,H15,H16,H17,H18,H20,H21,H24,H25,H26,H27,H28,MMM	
12	PAOZZ	5310012925354	19207	12338186-20	WASHER,FLAT PART OF KIT P/N 57K0109.	1
					UOC:H11,H13,H14,H17,H18,H20,H21,H24,H25,H26,H27,H28,MMM	
12	PAOZZ	5310013377034	19207	12338186-62	WASHER,FLAT PART OF KIT P/N 5742041.	1
					UOC:H15,H16	

END OF FIGURE



Section II.

TM 9-2320-280-24P-1

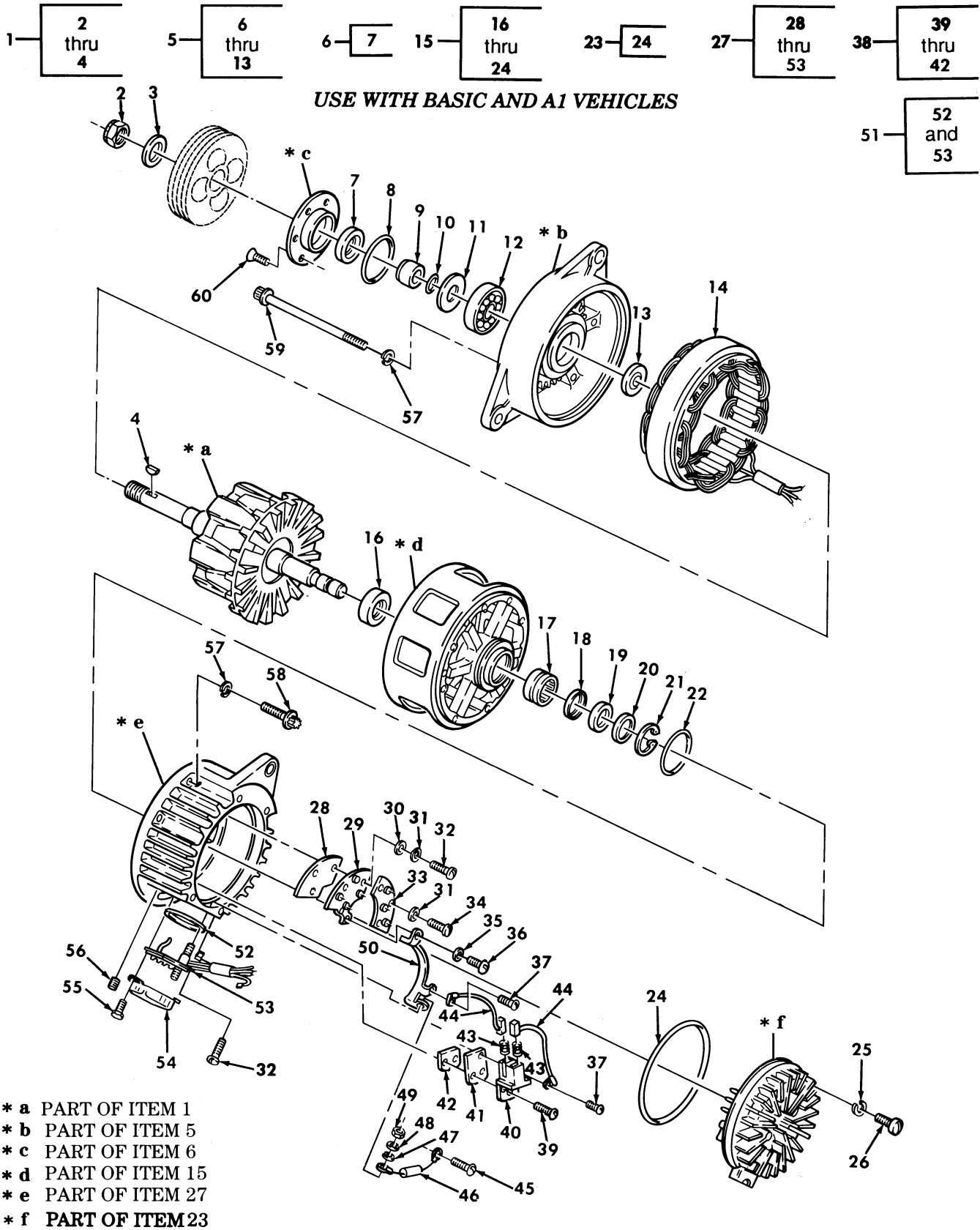

Figure 43. Generator Assembly (60 AMP).

SECTION II			TM9-2320-280-24P			
(1)	(2)	(3)	(4)	(5)	(6)	(7)
ITEM	SMR			PART		
NO	CODE	NSN	CAGEC	NUMBER	DESCRIPTION AND USABLE ON CODES(UOC)	QTY
GROUP 0601 GENERATOR: ALTERNATOR						
FIG. 43 GENERATOR ASSEMBLY (60 AMP)						
1	PAFZZ	2920012444993	19712	8MA-3010AS	ROTOR,GENERATOR.....	1
					UOC:A11,A13,A14,A20,A24,A25,A26,A27, B17,B18,H11,H13,H14,H17,H18,H20,H21, H24,H25,H26,H27,H28,MMM	
2	KFFZZ		19728	AMA-75	.NUT 5/8 X 12 PART OF KIT P/N 90- 2188.....	1
					UOC:A11,A13,A14,A20,A24,A25,A26,A27, B17,B18,H11,H13,H14,H17,H18,H20,H21, H24,H25,H26,H27,H28,MMM	
3	KFFZZ		19728	AMA-74	.WASHER,FLAT PART OF KIT P/N 90-2188	1
					UOC:A11,A13,A14,A20,A24,A25,A26,A27, B17,B18,H11,H13,H14,H17,H18,H20,H21, H24,H25,H26,H27,H28,MMM	
4	PAFZZ	5315006165514	80205	MS35756-6	.KEY,WOODRUFF PART OF KIT P/N 90- 2188.....	1
					UOC:A11,A13,A14,A20,A24,A25,A26,A27, B17,B18,H11,H13,H14,H17,H18,H20,H21, H24,H25,H26,H27,H28,MMM	
5	PAFZZ	2920012482509	68505	14-273	END BELL,ELECTRICAL.....	1
					UOC:A11,A13,A14,A20,A24,A25,A26,A27, B17,B18,H11,H13,H14,H17,H18,H20,H21, H24,H25,H26,H27,H28,MMM	
6	KFFZZ		19728	AMA-1014A	.RETAINER ASSEMBLY PART OF KIT P/N 90-2531.....	1
					UOC:A11,A13,A14,A15,A20,A24,A25,B16, B17,B18,H11,H13,H14,H17,H18,H20,H21, H24,H25,H26,H27,H28,MMM	
7	PFFZZ		19728	XA-1316	..SEAL KIT PART OF KIT P/N 90-2531..	1
					UOC:A11,A13,A14,A20,A24,A25,A26,A27, B17,B18,H11,H13,H14,H17,H18,H20,H21, H24,H25,H26,H27,H28,MMM	
8	KFFZZ		19728	XA-744AV	.SPRING SEAL BEARING PART OF KIT P/N 90-2531.....	1
					UOC:A11,A13,A14,A20,A24,A25,A26,A27, B17,B18,H11,H13,H14,H17,H18,H20,H21, H24,H25,H26,H27,H28,MMM	
9	KFFZZ		19728	AMA-66A	.SPACER PART OF KIT P/N 90-2531.....	1
					UOC:A11,A13,A14,A20,A24,A25,A26,A27, B17,B18,H11,H13,H14,H17,H18,H20,H21, H24,H25,H26,H27,H28,MMM	
10	KFFZZ		19728	XA-744AY	.O-RING .726 O.D. PART OF KIT P/N 90-2531.....	1
					UOC:A11,A13,A14,A20,A24,A25,A26,A27, B17,B18,H11,H13,H14,H17,H18,H20,H21, H24,H25,H26,H27,H28,MMM	
11	KFFZZ		19728	AMA-90	.WASHER PART OF KIT P/N 90-2531.....	1
					UOC:A11,A13,A14,A20,A24,A25,A26,A27, B17,B18,H11,H13,H14,H17,H18,H20,H21, H24,H25,H26,H27,H28,MMM	

SECTION II			TM9-2320-280-24P			
(1)	(2)	(3)	(4)	(5)	(6)	(7)
ITEM	SMR			PART		
NO	CODE	NSN	CAGEC	NUMBER	DESCRIPTION AND USABLE ON CODES(UOC)	QTY
12	KFFZZ		19728	X-4070	.BEARING,BALL PART OF KIT P/N 90-2531..... UOC:A11,A13,A14,A20,A24,A25,A26,A27,B17,B18,H11,H13,H14,H17,H18,H20,H21,H24,H25,H26,H27,H28,MMM	1
13	KFFZZ		19728	XA-1316	.SEAL KIT PART OF KIT P/N 90-2531... UOC:A11,A13,A14,A20,A24,A25,A26,A27,B17,B18,H11,H13,H14,H17,H18,H20,H21,H24,H25,H26,H27,H28,MMM	1
14	XAFZZ		19728	AMA-3008	STATOR ASSEMBLY..... UOC:A11,A13,A14,A20,A24,A25,A26,A27,B17,B18,H11,H13,H14,H17,H18,H20,H21,H24,H25,H26,H27,H28,MMM	1
15	KFFZZ		19728	AMA-5AS	END HEAD PART OF KIT P/N 90-2531.... UOC:A11,A13,A14,A20,A24,A25,A26,A27,B17,B18,H11,H13,H14,H17,H18,H20,H21,H24,H25,H26,H27,H28,MMM	1
16	KFFZZ		19728	XA-1317	.SEAL PART OF KIT P/N 90-2532..... UOC:A11,A13,A14,A20,A24,A25,A26,A27,B17,B18,H11,H13,H14,H17,H18,H20,H21,H24,H25,H26,H27,H28,MMM	1
17	KFFZZ		80293	X-4071	.BEARING,OUTER PART OF KIT P/N 90-2532..... UOC:A11,A13,A14,A20,A24,A25,A26,A27,B17,B18,H11,H13,H14,H17,H18,H20,H21,H24,H25,H26,H27,H28,MMM	1
18	KFFZZ		19728	AMA-50	.RETAINER,FELT PART OF KIT P/N 90-2532..... UOC:A11,A13,A14,A20,A24,A25,A26,A27,B17,B18,H11,H13,H14,H17,H18,H20,H21,H24,H25,H26,H27,H28,MMM	1
19	KFFZZ		19728	X-4059	.WASHER,FELT PART OF KIT P/N 90-2532 UOC:A11,A13,A14,A20,A24,A25,A26,A27,B17,B18,H11,H13,H14,H17,H18,H20,H21,H24,H25,H26,H27,H28,MMM	1
20	KFFZZ		19728	AMA-49	.RETAINER,FELT PART OF KIT P/N 90-2532..... UOC:A11,A13,A14,A20,A24,A25,A26,A27,B17,B18,H11,H13,H14,H17,H18,H20,H21,H24,H25,H26,H27,H28,MMM	1
21	KFFZZ		19728	X-4328	.RETAINER,BEARING PART OF KIT P/N 90-2532..... UOC:A11,A13,A14,A20,A24,A25,A26,A27,B17,B18,H11,H13,H14,H17,H18,H20,H21,H24,H25,H26,H27,H28,MMM	1
22	KFFZZ		68505	XA-744AV	.O-RING PART OF KIT P/N 90-2532..... UOC:A11,A13,A14,A20,A24,A25,A26,A27,B17,B18,H11,H13,H14,H17,H18,H20,H21,H24,H25,H26,H27,H28,MMM	1
23	PAFZZ	2920011808666	0EDY1	AMA2004AS	.PARTS KIT,ENGINE GE..... UOC:A11,A13,A14,A20,A24,A25,A26,A27,B17,B18,H11,H13,H14,H17,H18,H20,H21,H24,H25,H26,H27,H28,MMM	1

SECTION II			TM9-2320-280-24P			
(1)	(2)	(3)	(4)	(5)	(6)	(7)
ITEM NO	SMR CODE	NSN	CAGEC	PART NUMBER	DESCRIPTION AND USABLE ON CODES(UC)	QTY
24	KFFZZ		19728	XA-744AW	..RING SEAL BEARING PART OF KIT P/N 90-2532..... UOC:A11,A13,A14,A20,A24,A25,A26,A27,B17,B18,H11,H13,H14,H17,H18,H20,H21,H24,H25,H26,H27,H28,MMM	1
25	KFFZZ		19728	12X-195	WASHER,LOCK #8 PART OF KIT P/N 90-2187..... UOC:A11,A13,A14,A20,A24,A25,A26,A27,B17,B18,H11,H13,H14,H17,H18,H20,H21,H24,H25,H26,H27,H28,MMM	6
26	PAOZZ	5305014299137	68505	20X-4383	SCREW,TAPPING #8-32 X 1/2 PART OF KIT P/N 90-2187..... UOC:A11,A13,A14,A20,A24,A25,A26,A27,B17,B18,H11,H13,H14,H17,H18,H20,H21,H24,H25,H26,H27,H28,MMM	6
27	PAFZZ	2920011684131	68505	12-333	PARTS KIT,GENERATOR..... UOC:A11,A13,A14,A20,A24,A25,A26,A27,B17,B18,H11,H13,H14,H17,H18,H20,H21,H24,H25,H26,H27,H28,MMM	1
28	PAFZZ	5970012380146	68505	AMA-0045	.INSULATOR,PLATE PART OF KIT P/N AMA-1046AS..... UOC:A11,A13,A14,A20,A24,A25,A26,A27,B17,B18,H11,H13,H14,H17,H18,H20,H21,H24,H25,H26,H27,H28,MMM	1
29	KFFZZ		19728	AMA-1046A	.RECTIFIER,HEAT POSITIVE PART OF KIT P/N AMA-1046AS..... UOC:A11,A13,A14,A20,A24,A25,A26,A27,B17,B18,H11,H13,H14,H17,H18,H20,H21,H24,H25,H26,H27,H28,MMM	1
30	PAFZZ	5310012147785	68505	VSF-16	.WASHER,FLAT #6..... UOC:A11,A13,A14,A20,A24,A25,A26,A27,B17,B18,H11,H13,H14,H17,H18,H20,H21,H24,H25,H26,H27,H28,MMM	3
31	PAFZZ	5310013034701	96906	MS51412-1	.WASHER,FLAT #6..... UOC:A11,A13,A14,A20,A24,A25,A26,A27,B17,B18,H11,H13,H14,H17,H18,H20,H21,H24,H25,H26,H27,H28,MMM	6
32	PAFZZ	5305012153985	24617	9419836	.SCREW,ASSEMBLED WAS #6-32 X 3/8... UOC:A11,A13,A14,A20,A24,A25,A26,A27,B17,B18,H11,H13,H14,H17,H18,H20,H21,H24,H25,H26,H27,H28,MMM	7
33	PAFZZ	2920011684132	68505	AMA-1042AS	.PARTS KIT,ENGINE GE..... UOC:A11,A13,A14,A20,A24,A25,A26,A27,B17,B18,H11,H13,H14,H17,H18,H20,H21,H24,H25,H26,H27,H28,MMM	1
34	PAFZZ	5305008893000	96906	MS35206-230	.SCREW,MACHINE #6-32 X 1/2..... UOC:A11,A13,A14,A20,A24,A25,A26,A27,B17,B18,H11,H13,H14,H17,H18,H20,H21,H24,H25,H26,H27,H28,MMM	3
35	KFFZZ		68505	12X-196	.WASHER,LOCK #10 PART OF KIT P/N 90-2187..... UOC:A11,A13,A14,A20,A24,A25,A26,A27,B17,B18,H11,H13,H14,H17,H18,H20,H21,H24,H25,H26,H27,H28,MMM	1

SECTION II			TM9-2320-280-24P			
(1)	(2)	(3)	(4)	(5)	(6)	(7)
ITEM NO	SMR CODE	NSN	CAGEC	PART NUMBER	DESCRIPTION AND USABLE ON CODES(UC)	QTY
36	PAFZZ	5305009906444	96906	MS35207-261	.SCREW,MACHINE #10-32 X 3/8..... UOC:A11,A13,A14,A20,A24,A25,A26,A27, B17,B18,H11,H13,H14,H17,H18,H20,H21, H24,H25,H26,H27,H28,MMM	1
37	PAFZZ	5305009930190	96906	MS35206-214	.SCREW,MACHINE #4-40 X 5/16..... UOC:A11,A13,A14,A20,A24,A25,A26,A27, B17,B18,H11,H13,H14,H17,H18,H20,H21, H24,H25,H26,H27,H28,MMM	2
38	PAFZZ	2920012058653	68505	AMA-1015AS	.PARTS KIT,ENGINE GE..... UOC:A11,A13,A14,A20,A25,A26,A27,B17, B18,H11,H13,H14,H17,H18,H20,H21,H24, H25,H26,H27,H28,MMM	2
39	PAFZZ	5305008893001	96906	MS35206-231	..SCREW,MACHINE #6-32 X 5/8..... UOC:A11,A13,A14,A20,A24,A25,A26,A27, B17,B18,H11,H13,H14,H17,H18,H20,H21, H24,H25,H26,H27,H28,MMM	2
40	KFFZZ		68505	AMA-1015SS	..HOLDER,ELECTRICAL C PART OF KIT P/N 90-2187..... UOC:A11,A13,A14,A20,A24,A25,A26,A27, B17,B18,H11,H13,H14,H17,H18,H20,H21, H24,H25,H26,H27,H28,MMM	1
41	PAFZZ	5970012174566	68505	AMA-48	..INSULATOR,PLATE..... UOC:A11,A13,A14,A20,A24,A25,A26,A27, B17,B18,H11,H13,H14,H17,H18,H20,H21, H24,H25,H26,H27,H28,MMM	1
42	PAFZZ	5970012147806	68505	AMA-1026AS	..INSULATOR,PLATE..... UOC:A11,A13,A14,A20,A24,A25,A26,A27, B17,B18,H11,H13,H14,H17,H18,H20,H21, H24,H25,H26,H27,H28,MMM	1
43	KFFZZ		19728	AMA-19	..SPRING PART OF KIT P/N AMA-19S..... UOC:A11,A13,A14,A20,A24,A25,A26,A27, B17,B18,H11,H13,H14,H17,H18,H20,H21, H24,H25,H26,H27,H28,MMM	2
44	KFFZZ		19728	AMA-12	..BRUSH PART OF KIT P/N 01-05479..... UOC:A11,A13,A14,A20,A24,A25,A26,A27, B17,B18,H11,H13,H14,H17,H18,H20,H21, H24,H25,H26,H27,H28,MMM	2
45	PAFZZ	5305010766308	96906	MS51863-22	.SCREW,TAPPING #6-32 X 3/8..... UOC:A11,A13,A14,A20,A24,A25,A26,A27, B17,B18,H11,H13,H14,H17,H18,H20,H21, H24,H25,H26,H27,H28,MMM	1
46	PAFZZ	5910012181675	68505	AMA1096	.CAPACITOR,FIXED,PLA..... UOC:A11,A13,A14,A20,A24,A25,A26,A27, B17,B18,H11,H13,H14,H17,H18,H20,H21, H24,H25,H26,H27,H28,MMM	1
47	PAFZZ	5310011023270	24617	2436161	.WASHER,FLAT 1/4..... UOC:A11,A13,A14,A20,A24,A25,A26,A27, B17,B18,H11,H13,H14,H17,H18,H20,H21, H24,H25,H26,H27,H28,MMM	1
48	PAFZZ	5310006379541	96906	MS35338-46	.WASHER,LOCK 1/4..... UOC:A11,A13,A14,A20,A24,A25,A26,A27, B17,B18,H11,H13,H14,H17,H18,H20,H21, H24,H25,H26,H27,H28,MMM	1

SECTION II			TM9-2320-280-24P			
(1)	(2)	(3)	(4)	(5)	(6)	(7)
ITEM NO	SMR CODE	NSN	CAGEC	PART NUMBER	DESCRIPTION AND USABLE ON CODES(UC)	QTY
49	PAFZZ	5310007680319	96906	MS51968-2	.NUT,PLAIN,HEXAGON 1/4-28..... UOC:A11,A13,A14,A20,A24,A25,A26,A27, B17,B18,H11,H13,H14,H17,H18,H20,H21, H24,H25,H26,H27,H28,MMM	1
50	PAFZZ	2920012125816	68505	AMA-95	.STRAP,OUTPUT,GENERA..... UOC:A11,A13,A14,A20,A24,A25,A26,A27, B17,B18,H11,H13,H14,H17,H18,H20,H21, H24,H25,H26,H27,H28,MMM	1
51	XAFZZ		19728	AMA-2028BS	.PLATE,WIRING HARNES..... UOC:A11,A13,A14,A20,A24,A25,A26,A27, B17,B18,H11,H13,H14,H17,H18,H20,H21, H24,H25,H26,H27,H28,MMM	1
52	PAFZZ	5330012155124	68505	AMA-2028B5	..PACKING,PREFORMED..... UOC:A11,A13,A14,A20,A24,A25,A26,A27, B17,B18,H11,H13,H14,H17,H18,H20,H21, H24,H25,H26,H27,H28,MMM	1
53	PAFZZ	2920012125817	68505	AMA-2028BS	..PLATE,WIRING HARNES..... UOC:A11,A13,A14,A20,A24,A25,A26,A27, B17,B18,H11,H13,H14,H17,H18,H20,H21, H24,H25,H26,H27,H28,MMM	1
54	PAFZZ	2920011684127	68505	35-762	PARTS KIT,GENERATOR..... UOC:A11,A13,A14,A20,A24,A25,A26,A27, B17,B18,H11,H13,H14,H17,H18,H20,H21, H24,H25,H26,H27,H28,MMM	1
55	PAFZZ	5305006380714	78189	6-32 1-4	SCREW,ASSEMBLED WAS #6-32 X 1/4.... UOC:A11,A13,A14,A20,A24,A25,A26,A27, B17,B18,H11,H13,H14,H17,H18,H20,H21, H24,H25,H26,H27,H28,MMM	2
56	KFFZZ		19728	20X-4222	PLUG YOKE ADJUSTING PART OF KIT P/N 90-2187..... UOC:A11,A13,A14,A20,A24,A25,A26,A27, B17,B18,H11,H13,H14,H17,H18,H20,H21, H24,H25,H26,H27,H28,MMM	1
57	KFFZZ		68505	12X-196	WASHER,LOCK PART OF KIT P/N 90-2187 UOC:A11,A13,A14,A20,A24,A25,A26,A27, B17,B18,H11,H13,H14,H17,H18,H20,H21, H24,H25,H26,H27,H28,MMM	12
58	KFFZZ		19728	20X-4063	SCREW,TORX #10-24 X 1.00 PART OF KIT P/N 90-2187..... UOC:A11,A13,A14,A20,A24,A25,A26,A27, B17,B18,H11,H13,H14,H17,H18,H20,H21, H24,H25,H26,H27,H28,MMM	6
59	KFFZZ		19728	AMA-20	BOLT,THRU,TORX PART OF KIT P/N 90- 2187..... UOC:A11,A13,A14,A20,A24,A25,A26,A27, B17,B18,H11,H13,H14,H17,H18,H20,H21, H24,H25,H26,H27,H28,MMM	6
60	KFFZZ		19728	20X-4061	SCREW,FLAT HEAD PART OF KIT P/N 90- 2187..... UOC:A11,A13,A14,A20,A24,A25,A26,A27, B17,B18,H11,H13,H14,H17,H18,H20,H21, H24,H25,H26,H27,H28,MMM	6

END OF FIGURE

Section II.

TM 9-2320-280-24P-1

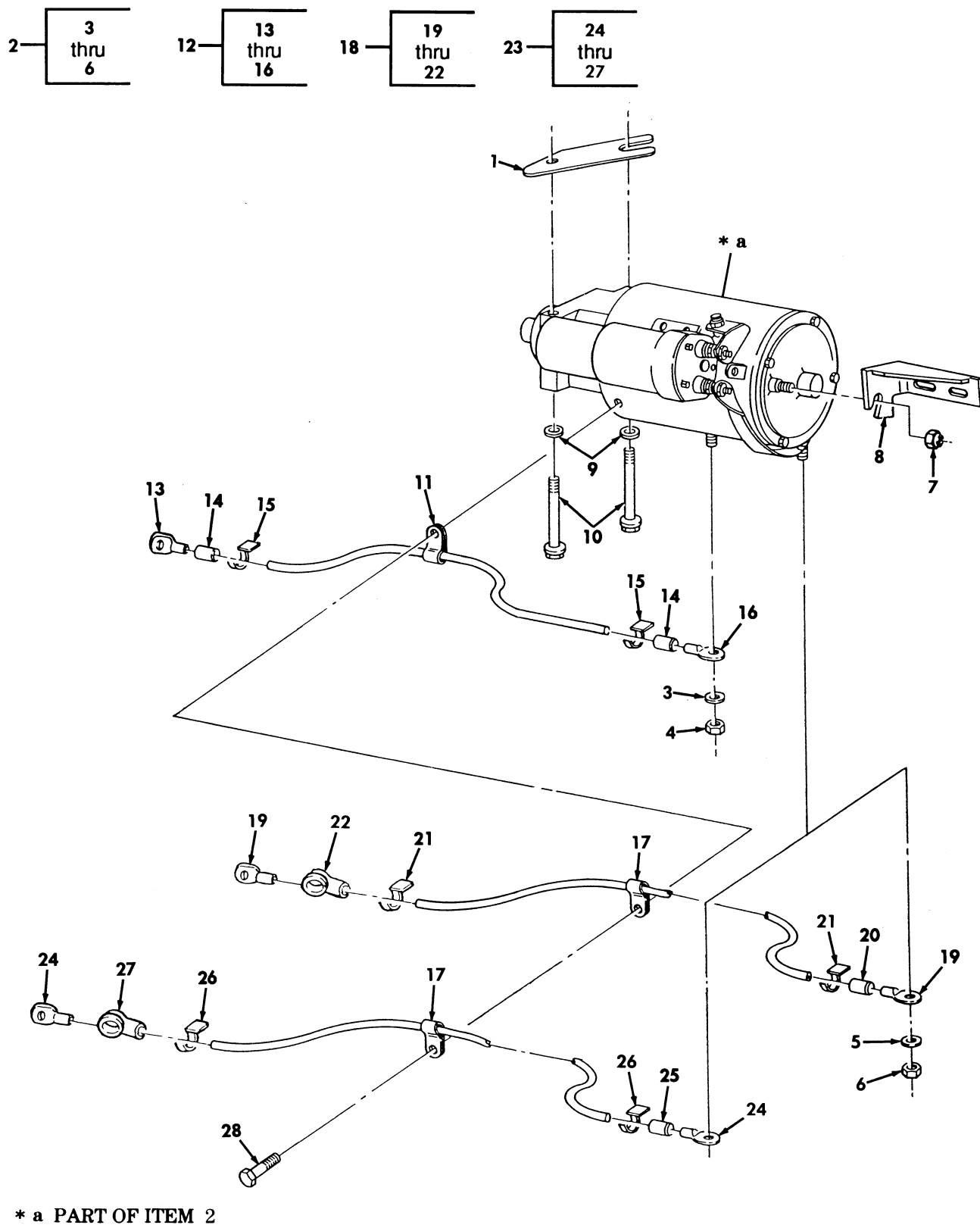

Figure 44. Starter Motor, Cable Assemblies, and Mounting Hardware.

SECTION II			TM9-2320-280-24P			
(1)	(2)	(3)	(4)	(5)	(6)	(7)
ITEM NO	SMR CODE	NSN	CAGEC	PART NUMBER	DESCRIPTION AND USABLE ON CODES(UOC)	QTY
GROUP 0603 STARTING MOTOR						
FIG. 44 STARTER MOTOR, CABLE ASSEMBLIES, AND MOUNTING HARDWARE						
1	PFOZZ	5365012104903	34623	5593694	SPACER, PLATE .080.....	V
2	PAOFF	2920011687891	68505	MFY-6701UT	STARTER, ENGINE, ELEC 24 VOLT.....	1
3	PAOZZ	5310006379541	96906	MS35338-46	.WASHER, LOCK 3/8.....	1
4	PAOZZ	5310007320558	96906	MS51967-8	.NUT, PLAIN, HEXAGON 3/8-16.....	1
5	PAOZZ	5310012167390	96906	MS51415-9	.WASHER, LOCK 1/2.....	1
6	PAOZZ	5310008348732	96906	MS35691-33	.NUT, PLAIN, HEXAGON 1/2-13.....	1
7	PAOZZ	5310003555645	82465	31WLF3816	NUT, PLAIN, ASSEMBLED 3/8-16.....	1
8	PAOZZ	5340014575734	34623	EX4939	BRACKET, ANGLE.....	1
9	PAOZZ	5310012866077	34623	5598627	WASHER, FLAT.....	2
10	PAOZZ	5305012854923	34623	12339413	SCREW, CAP, HEXAGON H.....	2
11	PAOZZ	5340009848541	96906	MS21333-106	CLAMP, LOOP NEGATIVE.....	1
12	MOOZZ		19207	12340048	CABLE ASSEMBLY GROUND, MAKE FROM WIRE, P/N M13486/1-14, 31 INCHES LONG UOC:AVY, A11, A14, A15, A20, A24, A25, A26, A27, B16, B17, B18, C17, HVY, H11, H13, H14, H15, H16, H17, H18, H20, H21, H24, H25, H26, H27, H28, MMM	1
12	MOOZZ		19207	12446821-4	CABLE ASSEMBLY, SPEC NEGATIVE, MAKE FROM WIRE, P/N M13486/1-14, LENGTH AS. UOC:BVY, B15, B20, B24, B25, C17, NNN	1
13	PAOZZ	5940007355520	56501	TG33	. TERMINAL, LUG.....	1
14	PAOZA	5970008276566	06090	CRN1RED	. INSULATION SLEEVING.....	2
15	PAOZZ	9905008933570	81349	M43436/1-3	. BAND, MARKER RED.....	3
16	PAOZZ	5940001155006	96906	MS25036-133	. TERMINAL, LUG.....	1
17	PAOZZ	5340008091494	96906	MS21333-105	CLAMP, LOOP.....	1
17	PAOZZ	5340008091494	96906	MS21333-105	UOC:A11, A13, A14, A20, A24, A25, A26, A27, B17, B18, B20, B24, B25, C17, H11, H13, H14, H17, H18, H20, H21, H24, H25, H26, H27, H28, MMM	2
18	MOOZZ		19207	12339316	CLAMP, LOOP.....	2
18	MOOZZ		19207	12339316-1	UOC:AVY, A15, BVY, B15, B16, HVY, H15, H16, NNN	1
18	MOOZZ		19207	12339316-1	CABLE ASSEMBLY POSITIVE, MAKE FROM WIRE, P/N M13486/1-14, 31 INCHES LONG. UOC:AVY, A11, A13, A14, A15, A20, A24, A25, A26, A27, B16, B17, B18, HVY, H11, H13, H14, H15, H16, H17, H18, H20, H21, H24, H25, H26, H27, H28, MMM	1
19	PAOZZ	5940007355520	56501	TG33	CABLE ASSEMBLY POSITIVE, MAKE FROM WIRE, P/N M13486/1-14, 31 INCHES LONG. UOC:BVY, B15, B20, B24, B25, C17, NNN	1
20	PAOZZ	5970002215301	14429	RESINITEEP69C	. TERMINAL, LUG.....	2
21	PAOZZ	9905008933570	81349	M43436/1-3	. INSULATION SLEEVING.....	1
22	PAOZZ	5975012089618	34623	5582481	. BAND, MARKER.....	3
23	MOOZZ		19207	12339317	. CABLE NIPPLE, ELECTR.....	1
23	MOOZZ		19207	12339317	LEAD, ELECTRICAL 200 AMP, MAKE FROM WIRE, P/N M13486/1-14, 58 INCHES LONG USE WITH 200 AMP ALT.....	1



SECTION II			TM9-2320-280-24P			
(1)	(2)	(3)	(4)	(5)	(6)	(7)
ITEM	SMR			PART		
NO	CODE	NSN	CAGEC	NUMBER	DESCRIPTION AND USABLE ON CODES(UC)	QTY
24	PAOZZ	5940007355520	56501	TG33	UC:AVY,A15,BVY,B15,B16,HVY,H15,H16, NNN . TERMINAL,LUG.....	2
25	PAOZZ	5970000579987	18876	8034668-159	UC:AVY,A15,BVY,B15,B16,HVY,H15,H16, NNN . INSULATION SLEEVING.....	1
26	PAOZZ	9905008933570	81349	M43436/1-3	UC:AVY,A15,BVY,B15,B16,HVY,H15,H16, NNN . BAND,MARKER.....	3
27	PAOZZ	5975012089618	34623	5582481	UC:AVY,A15,BVY,B15,B16,HVY,H15,H16, NNN . CABLE NIPPLE,ELECTR.....	1
28	PAOZZ	5305010396633	96906	MS51869-23	UC:AVY,A15,BVY,B15,B16,HVY,H15,H16, NNN SCREW,TAPPING 1/4-20 X 3/8.....	1

END OF FIGURE



SECTION II			TM9-2320-280-24P			
(1)	(2)	(3)	(4)	(5)	(6)	(7)
ITEM NO	SMR CODE	NSN	CAGEC	PART NUMBER	DESCRIPTION AND USABLE ON CODES(UOC)	QTY
GROUP 0603 STARTING MOTOR						
FIG. 45 STARTER MOTOR ASSEMBLY						
1	KFFZZ		19728	ML-129	WASHER,FLAT .31 THICK PART OF KIT P/N 90-2840.....	1
2	PAFFF	2990012055981	68505	MFY-1130	PLATE ASSEMBLY,STAR.....	1
3	PAFZZ	5330012097669	68505	XA-1642	.SEAL.....	1
4	PAFZZ	3120004256467	96906	MS17795-128	.BEARING,SLEEVE.....	1
5	KFFZZ		19728	13X-5549	.SCREW,FILL HEAD PART OF KIT P/N 90-2838.....	3
6	KFFZZ		19728	MFY-25	GASKET INTERMEDIATE PART OF KIT P/N 36-630.....	1
7	KFFZZ		19728	MFY-133	SPACER 0.108 THICK PART OF KIT P/N 90-2840.....	1
8	PAFZZ	2920011871310	68505	DRA-3002D	DRIVE,ENGINE,ELECTR.....	1
9	PAFZZ	5331001373450	19728	XA-744Z	O-RING 4-7/16.....	1
10	KFFZZ		19728	MFY-53	PINION STOP STARTER PART OF KIT P/N 90-2841.....	1
11	KFFZZ		19728	MCS-47A	SNAP RING STARTER PART OF KIT P/N 90-2841.....	1
12	PAFZZ	3010010686996	68505	MEU-2042B	SHIFTER FORK,NONVEH.....	1
13	KFFZZ		19728	MES-117A	PIN STRAIGHT PART OF KIT P/N 90-2206	2
14	KFFZZ		19728	20X-4222	PLUG YOKE ADJUSTING PART OF KIT P/N 90-2206.....	1
15	KFFZZ		19728	MFY-63	GASKET PLUG PART OF KIT P/N 90-2206.	1
16	KFFZZ		19728	MES-61	PLUG YOKE ADJUSTING PART OF KIT P/N 90-2206.....	1
17	PAFFF	2920012909245	68505	PS-1475SS	HOUSING,PINION,STAR.....	1
18	PAFZZ	3120004501905	24975	MEL50	.BEARING,SLEEVE.....	1
19	KFFZZ		19728	8X-4678	SCREW HEX HD PART OF KIT P/N 90-2836	7
20	PAFFF	5945012101299	68505	SAT4108UT	SOLENOID,ELECTRICAL.....	1
21	PAFZZ	2920011841054	68505	SAV-1008A	.CORE ASSEMBLY,SOLEN.....	1
22	KFFZZ		19728	8X-1681	.NUT PART OF KIT P/N 90-2206.....	1
23	KFFZZ		19728	6X-4336	.SNAP RING CORE END PART OF KIT P/N 90-816.....	1
24	KFFZZ		19728	SAT-48	.RETAINER CORE PART OF KIT P/N 90-816.....	1
25	KFFZZ		19728	SAT-52	.SPRING CORE PART OF KIT P/N 90-816.	1
26	KFFZZ		19728	SAT-47	.RETAINER CORE PART OF KIT P/N 90-816.....	1
27	KFFZZ		55883	IPD8S5128	.BOOT PART OF KIT P/N 90-816.....	1
28	KFFZZ		19728	SAT-46	.WASHER,SOLENOID PART OF KIT P/N 90-816.....	1
29	PAFZZ	5310012507844	68505	X-3331	.WASHER,LOCK.....	1
30	PAFZZ	5305009906444	96906	MS35207-261	.SCREW,MACHINE #10-32 X 3/8.....	1
31	KFFZZ		19728	SAT-1004F	.COVER AND CONTACT PART OF KIT P/N SAT-1004FS.....	1
32	KFFZZ		19728	SAT-32	.GASKET PART OF KIT P/N SAT-1004FS PART OF KIT P/N 37-123A.....	1
33	KFFZZ		19728	X-3508	.NUT HEXAGON ELASTIC PART OF KIT P/N 90-2225.....	1

SECTION II			TM9-2320-280-24P			
(1)	(2)	(3)	(4)	(5)	(6)	(7)
ITEM	SMR			PART		
NO	CODE	NSN	CAGEC	NUMBER	DESCRIPTION AND USABLE ON CODES(UOC)	QTY
34	KFFZZ		19728	8X-349	.WASHER PLAIN #10 PART OF KIT P/N 90-2225.....	1
35	KFFZZ		19728	SAT-1014B	.CONTACT ASSEMBLY PART OF KIT P/N 90-2225.....	1
36	KFFZZ		19728	SS-88A	.SPRING PART OF KIT P/N 90-2225.....	1
37	KFFZZ		19728	SAT-40	.WASHER STEEL #10 PART OF KIT P/N 90-2225.....	1
38	XBFZZ		19728	MBD-2566	ARMATURE,MOTOR.....	1
39	KFFZZ		19728	GK-174A	THRUST WASHER 0.0659 THICK PART OF KIT P/N 90-2840.....	1
40	KFFZZ		19728	ML-128A	THRUST WASHER .15 THICK PART OF KIT P/N 90-2840.....	8
41	PAFZZ	5330001380251	68505	MES-95S	GASKET.....	2
42	XAFZZ		19728	MFY-2101SS	FRAME AND FIELD ASY.....	2
43	PAFZZ	5305009897434	96906	MS35207-263	.SCREW,MACHINE #10-32 X 1/2.....	2
44	PAFZZ	5310012147784	68505	MZ-414S	.WASHER,FLAT.....	2
45	PAFZZ	5977013246323	68505	MFY-1064B	.HOLDER,ELECTRICAL C.....	1
46	KFFZZ		19728	MFJ-13A	.BRUSH STARTER MOTOR PART OF KIT P/N MFJ-2012BS.....	4
47	PAFZZ	5305009906444	96906	MS35207-261	.SCREW,MACHINE #10-32 X 3/8.....	2
48	KFFZZ		19728	MFY-19	.SPRING BRUSH PART OF KIT P/N MFY-19S.....	4
49	PAFZZ	5310009349751	96906	MS35650-302	.NUT,PLAIN,HEXAGON #10-32.....	2
50	PAFZZ	5310012144955	68505	92-2923	.WASHER,LOCK #10.....	2
51	PAFZZ	5305008893002	96906	MS35206-242	.SCREW,MACHINE #8-32 X 3/8.....	3
52	KFFZZ		19728	XA-744AP	.SEAL,O-RING STARTER PART OF KIT P/N 8S4680.....	3
53	KFFZZ		19728	MAW-37	BUSHING INSULATING PART OF KIT P/N 90-2837.....	1
54	KFFZZ		19728	MBD-444	WASHER,NEOPRENE PART OF KIT P/N 90-2837.....	1
55	KFFZZ		19728	MBD-438	WASHER INSULATING PART OF KIT P/N 90-2837.....	1
56	KFFZZ		19728	MBD-442	WASHER,CAP,STARTER PART OF KIT P/N 90-2837.....	1
57	KFFZZ		19728	MZ-294	WASHER PLAIN PART OF KIT P/N 90-2837	1
58	KFFZZ		19728	12X-201	WASHER LOCK PART OF KIT P/N 90-2837.	4
59	KFFZZ		19728	8X-179	NUT,HEXAGON 3/8-16 PART OF KIT P/N 90-2837.....	1
60	PFFZZ	5342012115327	34623	5741120	BRACKET,STARTER MOT.....	1
61	KFFZZ		19728	8X-830	NUT,HEXAGON 3/8-16 PART OF KIT P/N 90-2837.....	4
62	KFFZZ		19728	X-3925SC	WASHER INSULATING PART OF KIT P/N 90-2837.....	1
63	KFFZZ		19728	MBD-439	WASHER,PLAIN 3/8 PART OF KIT P/N 90-2837.....	1
64	KFFZZ		68505	MBD-233B	STUD,TERMINAL PART OF KIT P/N 90-2837.....	1
65	KFFZZ		19728	19X-4632	SCREW MACHINE #10-32 XN 3/4 PART OF KIT P/N 90-2836.....	4
66	KFFZZ		19728	MFY-21	STUD,TERMINAL PART OF KIT P/N 90-2837.....	1
67	PAFFF	2920012124976	68505	MFY1102S	END PLATE.....	1

SECTION II			TM9-2320-280-24P			
(1)	(2)	(3)	(4)	(5)	(6)	(7)
ITEM	SMR			PART		
NO	CODE	NSN	CAGEC	NUMBER	DESCRIPTION AND USABLE ON CODES(UC)	QTY
68	KFFZZ		19728	MAD-110A	.FELT OIL RETAINER PART OF KIT P/N 90-2838.....	1
69	KFFZZ		19728	MFY-117	.BEARING,ABS BRONZE PART OF KIT P/N 90-2838.....	1
70	KFFZZ		19728	MFJ-28A	STUD,TERMINAL PART OF KIT P/N 90-2837.....	1
71	KFFZZ		19728	MES-71A	WASHER,INSULATING PART OF KIT P/N 90-2837.....	1
72	KFFZZ		19728	MES-72	BUSHING,INSULATING PART OF KIT P/N 90-2837.....	1
73	KFFZZ		19728	MES-94	WASHER,NEOPRENE PART OF KIT P/N 90-2837.....	1
74	KFFZZ		19728	MES-93	WASHER,INSULATING PART OF KIT P/N 90-2837.....	1
75	KFFZZ		19728	MES-91	WASHER,CAP PART OF KIT P/N 90-2837..	1
76	KFFZZ		19728	37X-4914	SCREW HEX HD 1/4-20 X 3/8 PART OF KIT P/N 90-2836.....	4
77	KFFZZ		19728	MES-78A	WASHER,PLAIN PART OF KIT P/N 90-2837	1
78	KFFZZ		19728	19X-3437	NUT,HEXAGON 1/2-13 PART OF KIT P/N 90-2837.....	1
79	PFFZZ	2920012114935	68505	MFY-109	BRACKET,SOLENOID.....	1
80	KFFZZ		19728	12X-198	WASHER LOCK PART OF KIT P/N 90-2837.	2
81	KFFZZ		19728	8X-3439	NUT,HEXAGON 1/2-13 PART OF KIT P/N 90-2837.....	3

END OF FIGURE

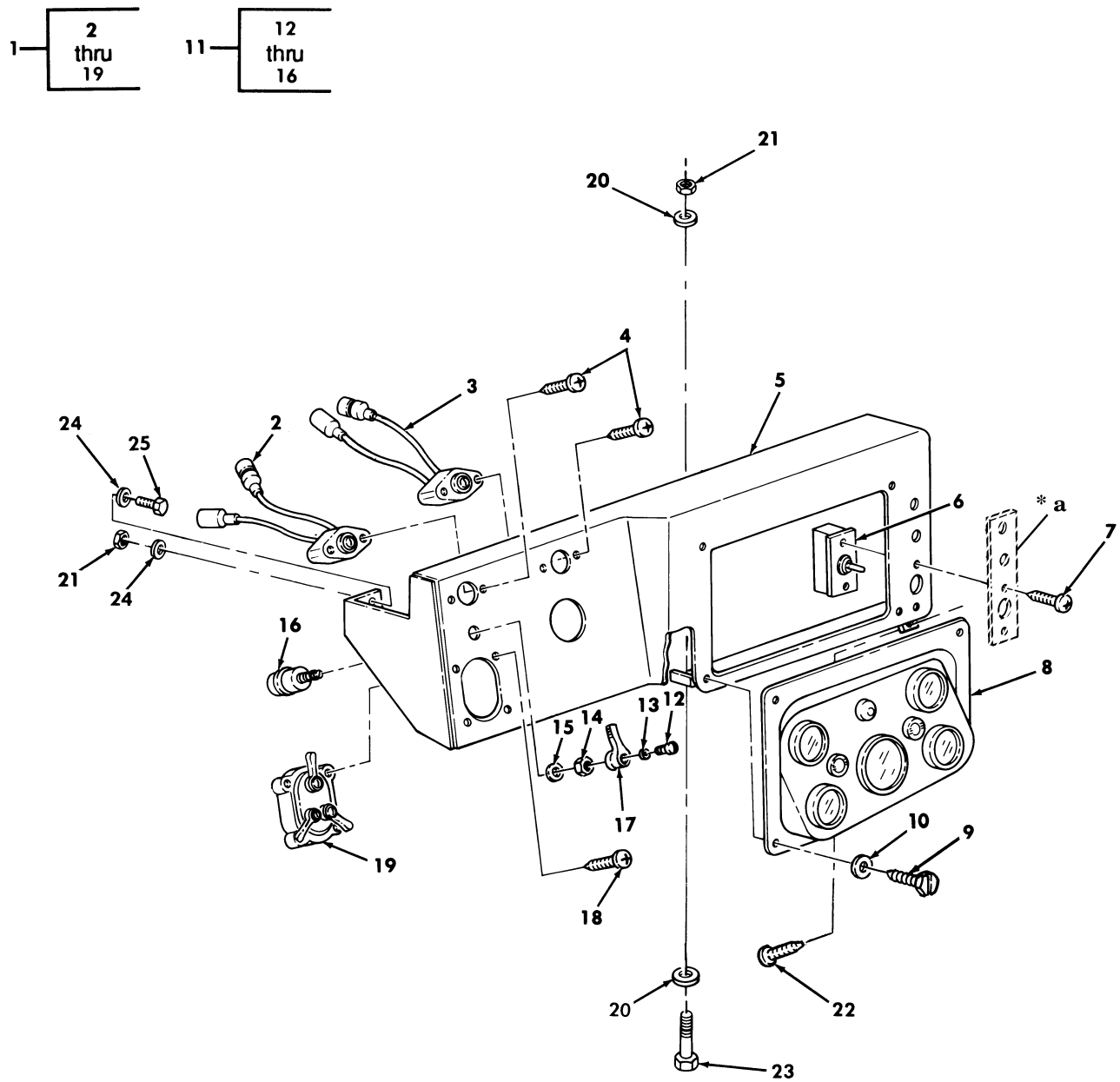
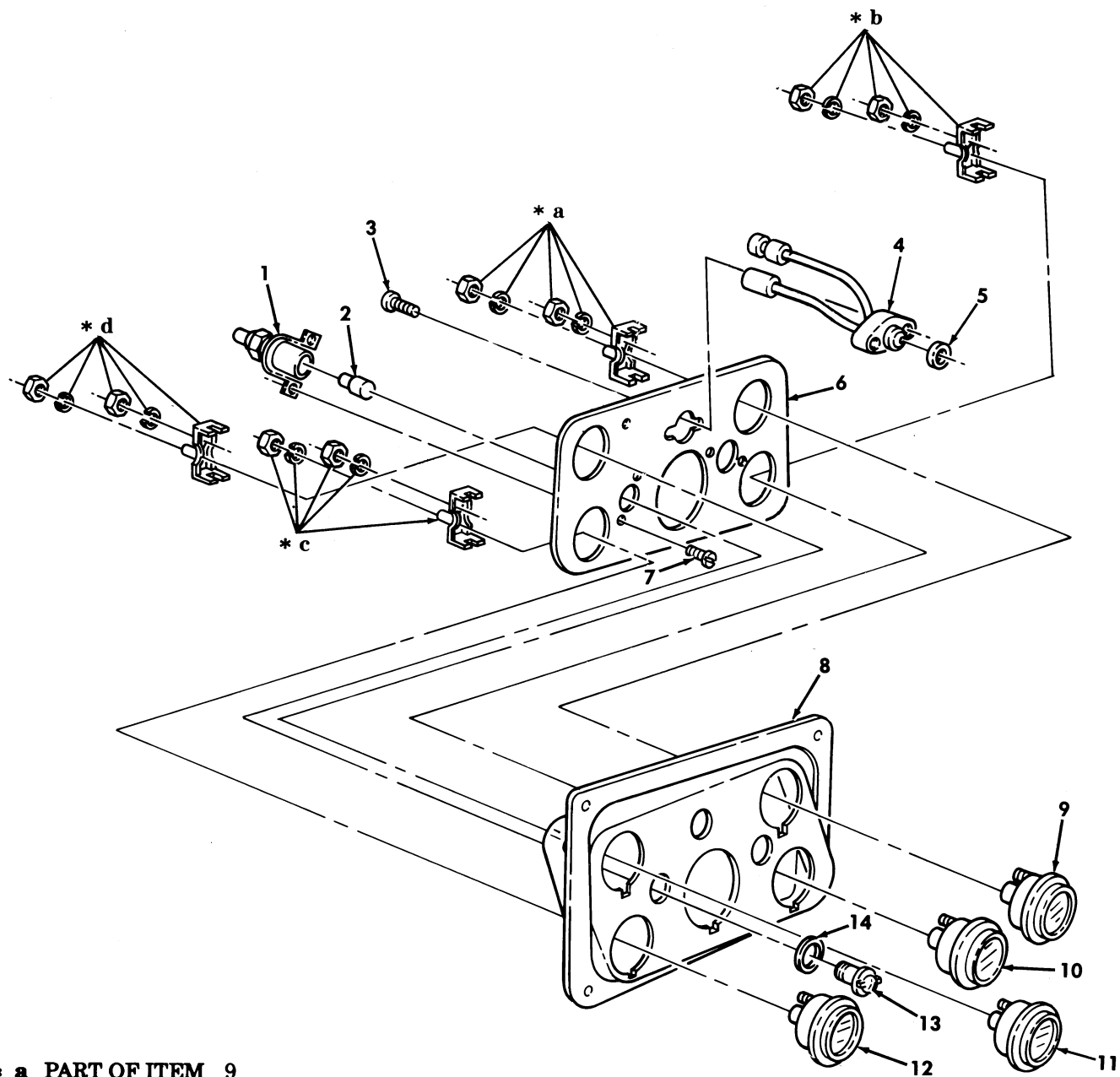

Figure 46. Instrument Panel Assembly and Mounting Hardware.

SECTION II			TM9-2320-280-24P			
(1)	(2)	(3)	(4)	(5)	(6)	(7)
ITEM	SMR			PART		
NO	CODE	NSN	CAGEC	NUMBER	DESCRIPTION AND USABLE ON CODES(UC)	QTY
					GROUP 0607 INSTRUMENT OR ENGINE CONTROL PANEL	
					FIG. 46 INSTRUMENT PANEL ASSEMBLY AND MOUNTING HARDWARE	
1	PFOOO	2510011872238	34623	12338477	PANEL,VEHICULAR OPE.....	1
2	PAOZZ	5980011868319	34623	5583395	.LIGHT EMITTING DIOD AMBER.....	1
3	PAOZZ	5980011870791	19207	12356703-1	.LIGHT EMITTING DIOD RED.....	1
4	PAOZZ	5305011389540	96906	MS51863-33	.SCREW,TAPPING #8-32 X 3/8.....	4
5	XAOZZ		34623	5581211	.PANEL INSTRUMENT.....	1
6	PAOZZ	5930002266429	96906	MS39061-4	.SWITCH,TOGGLE.....	1
7	PFOZZ	5305012645864	7X677	186965	.SCREW,ASSEMBLED WAS #10-32 X 3/4..	2
8	PFOZZ	2540011856117	19207	12338466	.INSTRUMENT PANEL,CA.....	1
9	PAOZZ	5305011878757	7X677	274707	.SCREW,MACHINE #10-24 X 1/2.....	4
10	PAOZZ	5310008098546	96906	MS27183-8	.WASHER,FLAT #10.....	4
11	PAOZZ	5930001345036	19207	11614131	.SWITCH,ROTARY.....	1
12	PAOZZ	5305006143423	96906	MS35265-43	..SCREW,MACHINE #8-32 X 3/8.....	1
13	PAOZZ	5310000453299	96906	MS35338-42	..WASHER,LOCK 1/2.....	1
14	PAOZZ	5310008326852	19207	5381233	..NUT,PLAIN,HEXAGON 1/2-20.....	1
15	PAOZZ	5310001941483	96906	MS35333-44	..WASHER,LOCK 1/2.....	1
16	XAOZZ		19207	11614131-1	..SWITCH.....	1
17	PAOZZ	5930001305349	19207	5381088	.HANDLE,SWITCH.....	1
18	PAOZZ	5305009953440	96906	MS35207-270	.SCREW,MACHINE #10-32 X 1.75.....	4
19	PAOZZ	5930003078856	96906	MS51113-1	.SWITCH ASSEMBLY.....	1
20	PAOZZ	5310012545352	34623	5593308	WASHER,FLAT 1/4.....	2
21	PAOZZ	5310000614650	96906	MS51943-31	NUT,SELF-LOCKING,HE 1/4-20.....	3
22	PAOZZ	5305012506583	34623	5592878	SCREW,TAPPING #10-24 X 1/2.....	1
23	PAOZZ	5305000680508	80204	B1821BH025C075N	SCREW,CAP,HEXAGON H 1/4-20 X 3/4...	1
24	PAOZZ	5310011023270	24617	2436161	WASHER,FLAT 1/4.....	4
25	PAOZZ	5305000687837	80204	B1821BH025C063N	SCREW,CAP,HEXAGON H 1/4-20 X 5/8...	2

END OF FIGURE



- \* a PART OF ITEM 9
- \* b PART OF ITEM 10
- \* c PART OF ITEM 12
- \* d PART OF ITEM 11

Figure 47. Instrument Cluster Assembly.



SECTION II			TM9-2320-280-24P			
(1)	(2)	(3)	(4)	(5)	(6)	(7)
ITEM	SMR			PART		
NO	CODE	NSN	CAGEC	NUMBER	DESCRIPTION AND USABLE ON CODES(UC)	QTY
					GROUP 0607 INSTRUMENT OR ENGINE CONTROL PANEL	
					FIG. 47 INSTRUMENT CLUSTER ASSEMBLY	
1	PAOZZ	6210012084790	19207	12338465	LIGHT,INDICATOR.....	2
2	PAOZZ	6240007658443	24455	1864	LAMP,INCANDESCENT CLEAR.....	2
					UOC:AVY,A11,A13,A14,A15,A20,A24,A25,A26,A27,B16,B17,B18,HVY,H11,H13,H14,H15,H16,H17,H18,H20,H21,H24,H25,H26,H27,H28,MMM	
2	PAOZZ	5980014387452	19207	12460228	SEMICONDUCTOR DEVIC PART OF KIT P/N 57K3238.....	2
					UOC:BVY,B15,B20,B24,B25,C17,NNN	
3	PAOZZ	5305012111439	7X677	9414224	SCREW,TAPPING.....	2
4	PAOZZ	6220012730500	19207	12356703-3	LIGHT,INDICATOR.....	1
5	PAOZZ	5330012115856	19207	12338462	GASKET.....	1
6	PFOZZ	2510012488875	19207	12338467	PANEL,VEHICULAR OPE.....	1
7	PAOZZ	5305009846191	96906	MS35206-243	SCREW,MACHINE #8-32 X 3/8.....	4
8	PFOZZ	2510013035769	34623	5585111	PANEL,VEHICULAR OPE.....	1
9	PAOZZ	6685011809037	09527	GG0490	INDICATOR,TEMPERATU.....	1
10	PAOZZ	6625011806542	34623	5568666	METER,ARBITRARY SCA.....	1
11	PAOZZ	6620011811757	09527	GG0552	GAGE,PRESSURE,DIAL.....	1
12	PAOZZ	6680012980498	34623	5568667	INDICATOR,LIQUID QU.....	1
13	PAOZZ	6210012117024	19207	12339203	LENS,LIGHT.....	2
					UOC:AVY,A11,A13,A14,A15,A20,A24,A25,A26,A27,B16,B17,B18,HVY,H11,H13,H14,H15,H16,H17,H18,H20,H21,H24,H25,H26,H27,H28,MMM	
13	PAOZZ	6220014294596	19207	12339203-1	LENS,LIGHT INSTRUMENT CLUSTER,CLEAR PART OF KIT P/N 57K3238.....	2
					UOC:BVY,B15,B20,B24,B25,C17,NNN	
14	PAOZZ	5330002976329	19207	7358626	PACKING,PREFORMED.....	2

END OF FIGURE

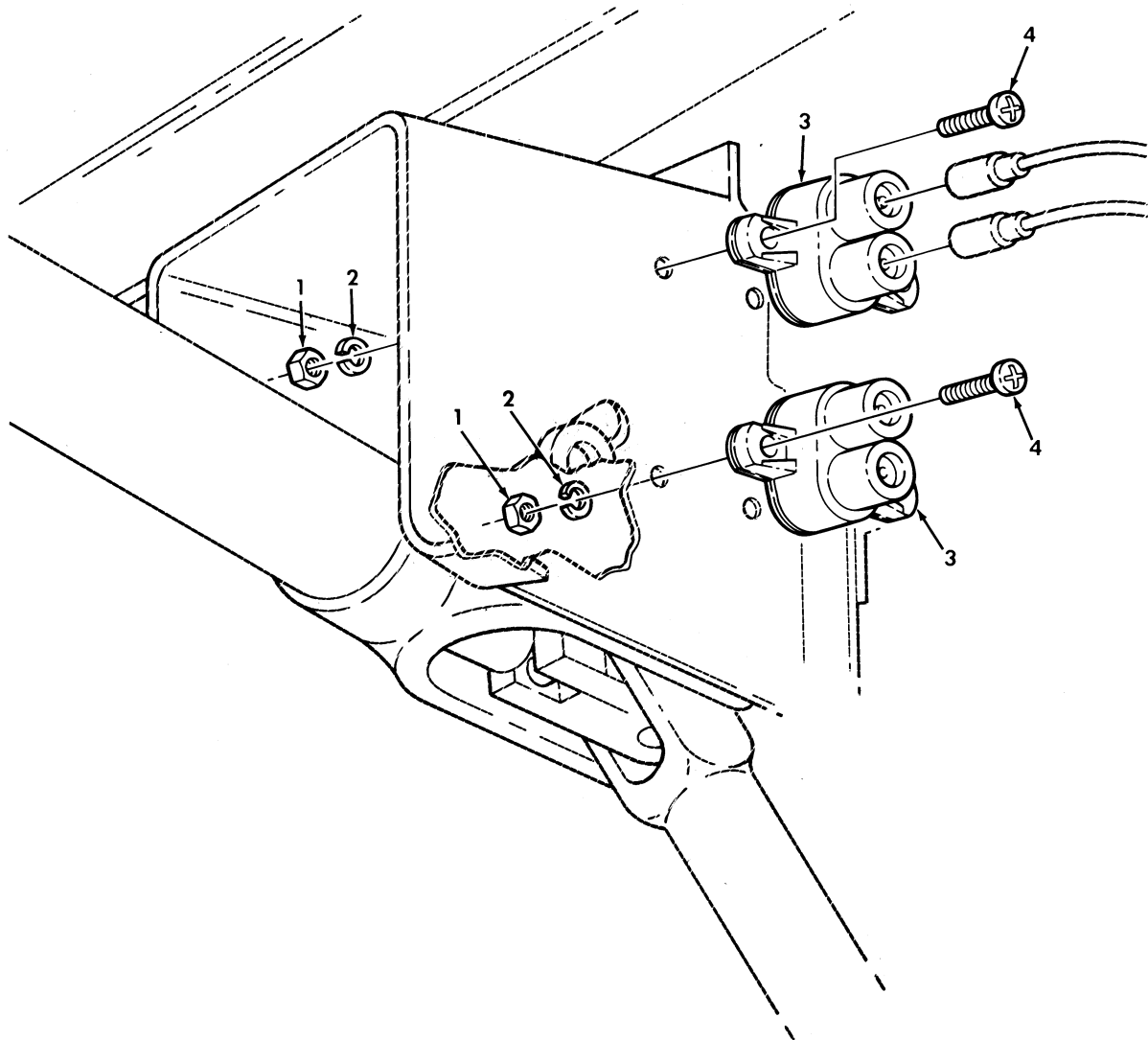
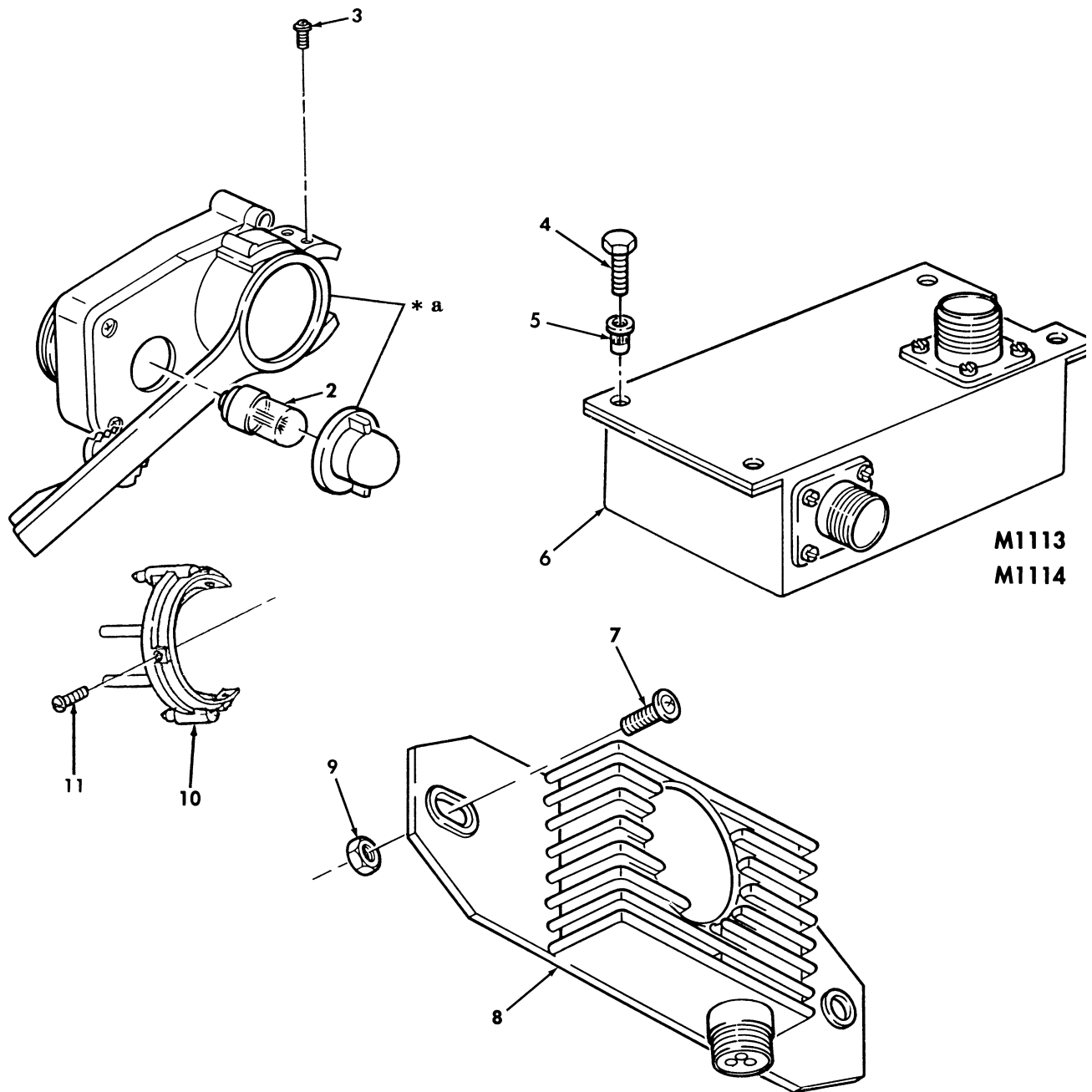

Figure 48. Circuit Breakers.

SECTION II			TM9-2320-280-24P			
(1)	(2)	(3)	(4)	(5)	(6)	(7)
ITEM	SMR			PART		
NO	CODE	NSN	CAGEC	NUMBER	DESCRIPTION AND USABLE ON CODES(UC)	QTY
					GROUP 0607 INSTRUMENT OR ENGINE CONTROL PANEL	
					FIG. 48 CIRCUIT BREAKERS	
1	PAOZZ	5310009349757	96906	MS35649-282	NUT,PLAIN,HEXAGON #8-32.....	4
2	PAOZZ	5310000453299	96906	MS35338-42	WASHER,LOCK #8.....	4
3	PAOZZ	5925014302318	58536	AA55571/01-001	CIRCUIT BREAKER.....	2
4	PAOZZ	5305009846195	96906	MS35206-247	SCREW,MACHINE #8-32 X 3/4.....	4

END OF FIGURE

1-2



\* a PART OF ITEM 1

Figure 49. Directional Control Unit, Protective Control Box, and Directional Flasher.

SECTION II			TM9-2320-280-24P			
(1)	(2)	(3)	(4)	(5)	(6)	(7)
ITEM NO	SMR CODE	NSN	CAGEC	PART NUMBER	DESCRIPTION AND USABLE ON CODES(UC)	QTY
GROUP 0608 MISCELLANEOUS ITEMS						
FIG. 49 DIRECTIONAL CONTROL UNIT, PROTECTIVE CONTROL BOX, AND DIRECTIONAL FLASHER						
1	PAOZZ	6220014087785	19207	12447083	CONTROL, DIRECTIONAL PART OF KIT P/N 57K3222.....	1
2	PAOZZ	6240004193185	96906	MS25231-1873	.LAMP, INCANDESCENT.....	1
3	PAOZZ	5305012116049	7X677	274233	SCREW, TAPPING #6-32 X 3/8 PART OF KIT P/N 57K3222.....	4
4	PAOZZ	6110014639260	19207	12469158	CONTROL, REMOTE SWIT COMES WITH ITEM 2 ON FIGURE 66.....	1
5	PAOZZ	6110014701931	19207	12469158-1	.CONTROL, REMOTE SWIT.....	1
6	PAOZZ	5310014113422	78278	ALS4-420-165	.NUT, PLAIN, BLIND RIV.....	4
7	PAOZZ	5305002253843	80204	B1821BH025C125N	SCREW, CAP, HEXAGON H 1/4-20 X 1.25..	4
8	PAOZZ	5305009881725	96906	MS35206-281	SCREW, MACHINE 1/4-20 X 3/4.....	2
9	PAOZZ	5945007893706	19207	11613631	FLASHER, THERMAL.....	1
10	PAOZZ	5310012510711	34623	5593038	NUT, PLAIN, HEXAGON 1/4-20.....	2
11	PAOZZ	6220014455058	19207	12447084	CONTROL, DIRECTIONAL PART OF KIT P/N 57K3222.....	1
12	PAOZZ	5305004324165	96906	MS51861-26	SCREW, TAPPING #6-20 X 5/8 PART OF KIT P/N 57K3222.....	3

END OF FIGURE

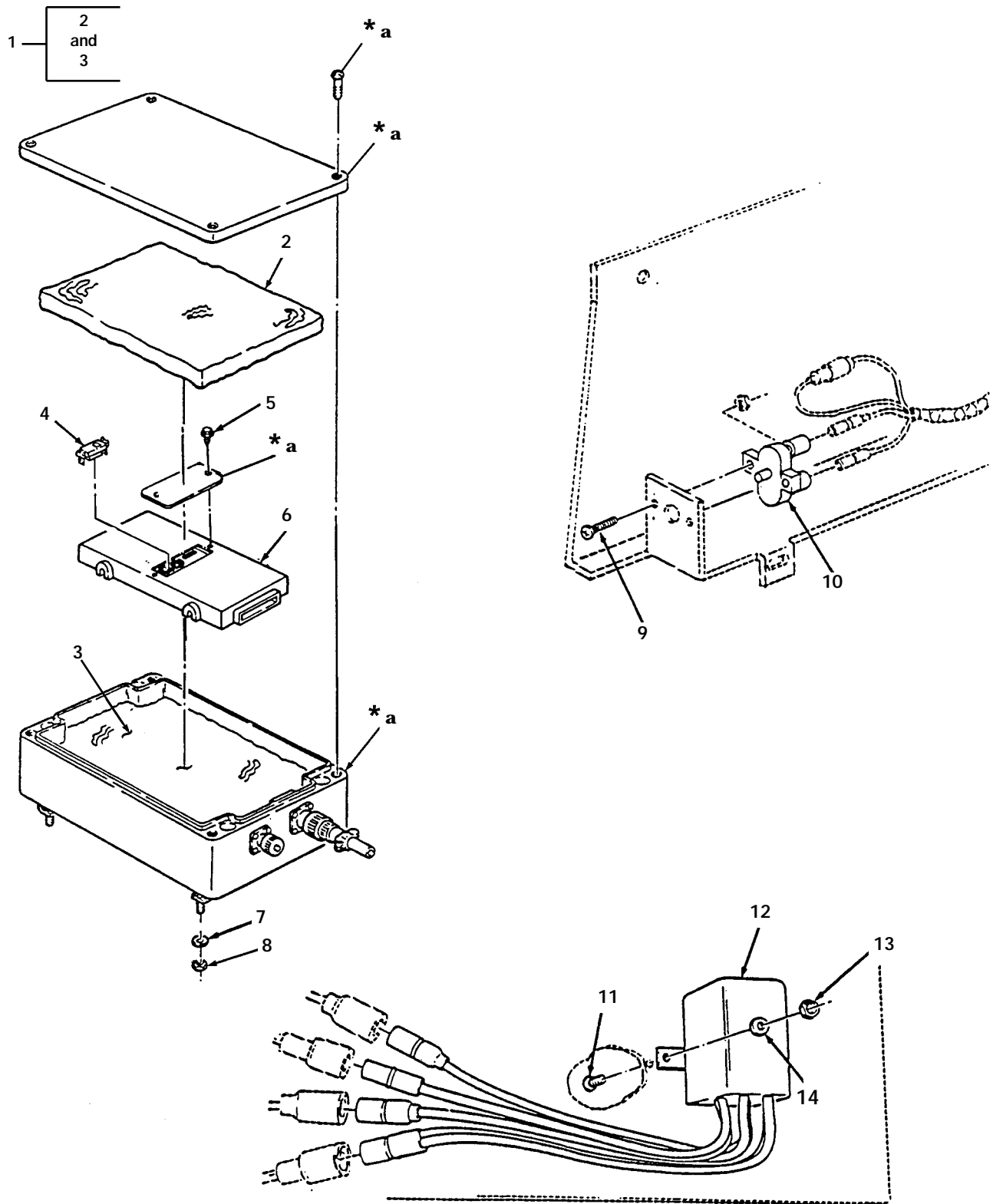

\* a PART OF ITEM 1

Figure 50. Transmission Control Module, Circuit Breaker, and Relay.

SECTION II			TM9-2320-280-24P			
(1)	(2)	(3)	(4)	(5)	(6)	(7)
ITEM NO	SMR CODE	NSN	CAGEC	PART NUMBER	DESCRIPTION AND USABLE ON CODES(UCO)	QTY
GROUP 0608 MISCELLANEOUS ITEMS						
FIG. 50 TRANSMISSION CONTROL MODULE, CIRCUIT BREAKER, AND RELAY						
1	PAOZZ		34623	12460399	CONTROL ASSEMBLY, TR.....	1
					UCO:BVY, B15, B20, B24, B25, C17, NNN	
2	PAOZZ		19207	12460407-2	.FOAM, CUSHION.....	1
					UCO:BVY, B15, B20, B24, B25, C17, NNN	
3	PAOZZ		19207	12460407-1	.FOAM CUSHION.....	1
					UCO:BVY, B15, B20, B24, B25, C17, NNN	
4	PAOZZ	5962014300182	16764	16197350	MICROCIRCUIT, LINEAR 1995.....	1
					UCO:BVY, B15, B20, B24, B25, C17, NNN	
4	PAOZZ	5962014300208	16764	16229203	MICROCIRCUIT, LINEAR 1996 PART OF KIT P/N 57K3502.....	1
					UCO:BVY, B15, B20, B24, B25, C17, NNN	
4	PAOZZ	5962014400368	16764	16251210	MICROCIRCUIT, LINEAR 1997 PART OF KIT P/N 57K3523.....	1
					UCO:BVY, B15, B20, B24, B25, C17, NNN	
4	PAOZZ	5962014704619	16764	16266408	MICROCIRCUIT, LINEAR 1998 PART OF KIT P/N 57K3539.....	1
					UCO:BVY, B15, B20, B24, B25, C17, NNN	
5	PAOZZ		24617	170982	SCREW, MACHINE.....	2
					UCO:BVY, B15, B20, B24, B25, C17, NNN	
6	PAOZZ	5940014302764	16764	16196390	TERMINAL BOX MINUS E-PROM... ..	1
					UCO:BVY, B15, B20, B24, B25, C17, NNN	
7	PAOZZ	5310014490628	96906	MS51412-36	WASHER, FLAT.....	4
					UCO:BVY, B15, B20, B24, B25, C17, NNN	
8	PAOZZ	5310000614650	96906	MS51943-31	NUT, SELF-LOCKING, HE 9/32-12.....	4
					UCO:BVY, B15, B20, B24, B25, C17, NNN	
9	PAOZZ	5305009846197	96906	MS35206-249	SCREW, MACHINE .164-32 X 1.00.....	2
					UCO:BVY, B15, B20, B24, B25, C17, NNN	
10	PAOZZ	5925008948015	58536	AA55571/02-001	CIRCUIT BREAKER.....	1
					UCO:BVY, B15, B20, B24, B25, C17, NNN	
11	PAOZZ	5305000680502	96906	MS90725-6	SCREW, CAP, HEXAGON H 1/4-20 X .750..	2
					UCO:BVY, B15, B20, B24, B25, C17, NNN	
12	PAOZZ	5945014130886	19207	12460116	RELAY, SOLID STATE.....	1
					UCO:BVY, B15, B20, B24, B25, C17, NNN	
13	PAOZZ	5310000881251	81349	M45913/1-4CG5C	NUT, SELF-LOCKING, HE 1/4-20.....	2
					UCO:BVY, B15, B20, B24, B25, C17, NNN	
14	PAOZZ	5310008094058	96906	MS27183-10	WASHER, FLAT 9/32.....	2
					UCO:BVY, B15, B20, B24, B25, C17, NNN	

END OF FIGURE

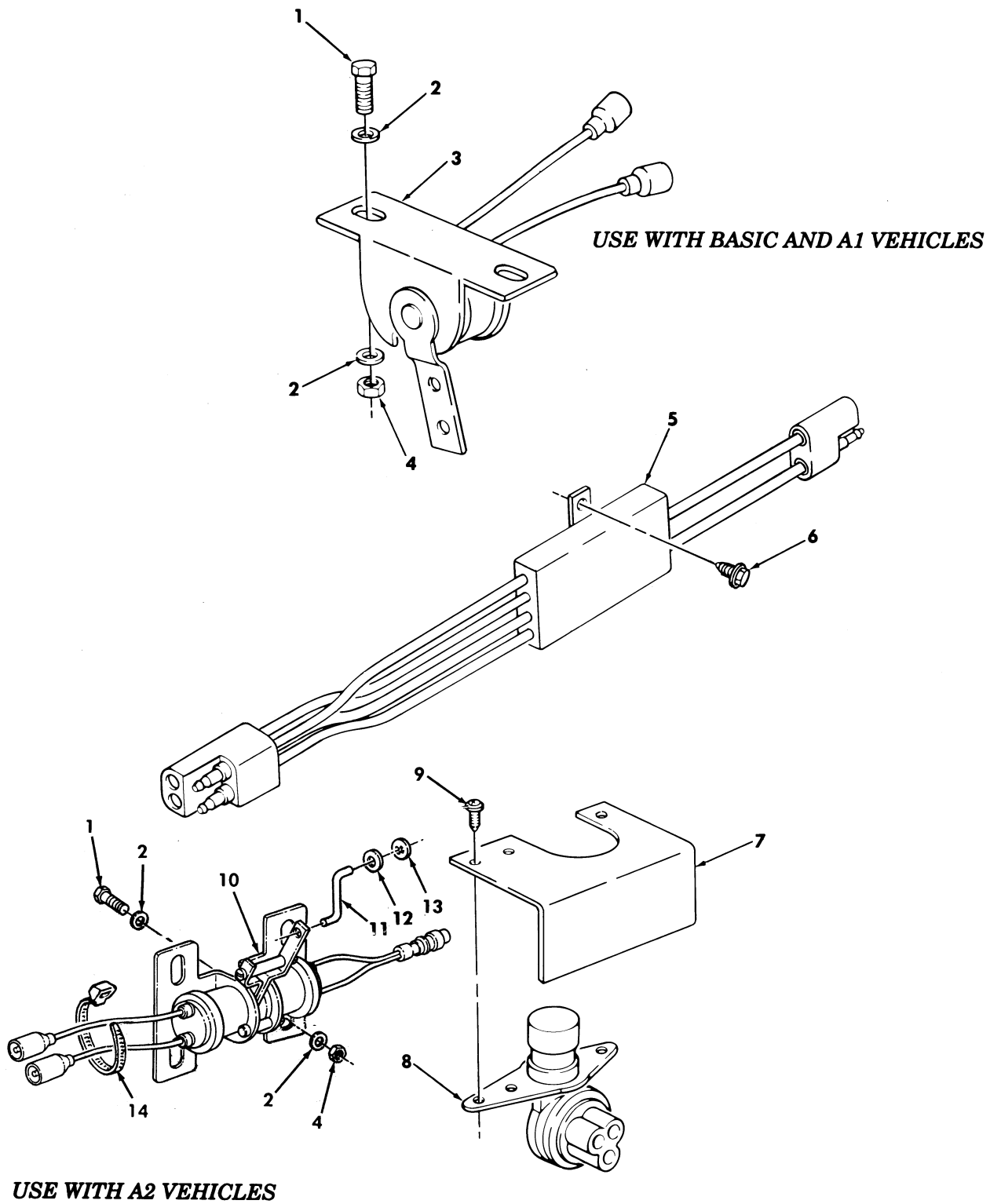

Figure 51. Stoplight Switch, Time Delay Module, and High Beam Selector Switch.



SECTION II			TM9-2320-280-24P			
(1)	(2)	(3)	(4)	(5)	(6)	(7)
ITEM NO	SMR CODE	NSN	CAGEC	PART NUMBER	DESCRIPTION AND USABLE ON CODES(UC)	QTY
GROUP 0608 MISCELLANEOUS ITEMS						
FIG. 51 STOPLIGHT SWITCH, TIME DELAY MODULE, AND HIGH BEAM SELECTOR SWITCH						
1	PAOZZ	5305009881725	96906	MS35206-281	SCREW, MACHINE 1/4-20 X .75.....	2
2	PAOZZ	5310008094058	96906	MS27183-10	WASHER, FLAT 1/4.....	4
3	PAOZZ	5930002079422	19207	11663279	SWITCH, ROTARY.....	1
					UOC:AVY,A11,A13,A14,A15,A20,A24,A25,A26,A27,B16,B17,B18,HVY,H11,H13,H14,H15,H16,H17,H18,H20,H21,H24,H25,H26,H27,H28,MMM	
4	PAOZZ	5310011520598	24617	271172	NUT, SELF-LOCKING, AS 1/4-20.....	2
5	PAOZZ	5945011937175	19207	12338603	RELAY, SOLID STATE.....	1
6	PAOZZ	5305012046502	78189	112-1008800-003	SCREW #10-32 X 1/2.....	2
7	PAOZZ	5340012097794	19207	12338726	BRACKET, ANGLE.....	1
8	PFOZZ	2590008012355	96906	MS53000-1	SWITCH, BEAM SELECTI.....	1
9	PAOZZ	5305004997694	24617	454542	SCREW, ASSEMBLED WAS 1/4-20 X 1/2...	3
10	PAOZZ	2540014108789	34623	RCSK17810	SWITCH, STOPLIGHT, AU.....	1
					UOC:BVY,B15,B20,B24,B25,C17,NNN	
11	PAOZZ	3040014445640	34623	12460229	CONNECTING LINK, RIG BRAKE LIGHT SWITCH.....	1
					UOC:BVY,B15,B20,B24,B25,C17,NNN	
12	PAOZZ	5310004022778	24617	9416128	WASHER, FLAT #10.....	2
					UOC:BVY,B15,B20,B24,B25,C17,NNN	
13	PAOZZ	5310011886861	19207	12339313	PUSH ON NUT 3/16 STUD.....	2
					UOC:BVY,B15,B20,B24,B25,C17,NNN	
14	PAOZZ	5975001338687	96906	MS3367-5-0	STRAP, TIEDOWN, ELECT.....	2
					UOC:BVY,B15,B20,B24,B25,C17,NNN	

END OF FIGURE

Section II.

TM 9-2320-280-24P-1

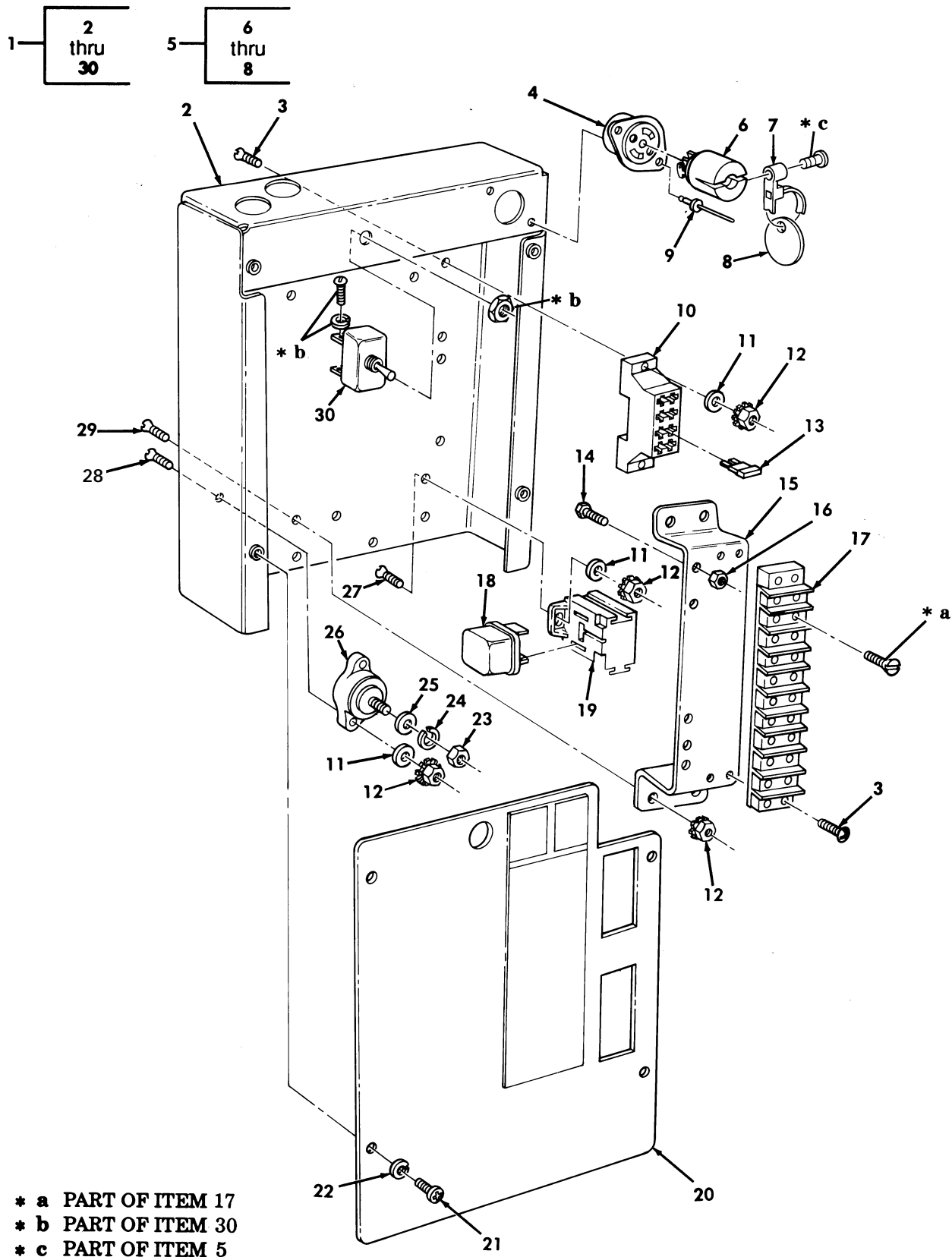

Figure 52. Control Box Assembly, M996, M996A1, M997, M997A1, and M997A2 Ambulance.

SECTION II			TM9-2320-280-24P			
(1)	(2)	(3)	(4)	(5)	(6)	(7)
ITEM NO	SMR CODE	NSN	CAGEC	PART NUMBER	DESCRIPTION AND USABLE ON CODES(UOC)	QTY
GROUP 0608 MISCELLANEOUS ITEMS						
FIG. 52 CONTROL BOX ASSEMBLY,M996, M996A1,M997,M997A1,AND M997A2 AMBULANCE						
1	PFOOO	2540012772313	19207	12341910	CONTROL BOX,ELECTRI.....	1
					UOC:A15,B15,B16,H15,H16	
2	XAOZZ		34623	5597128	.CONTROL BOX.....	1
					UOC:A15,B15,B16,H15,H16	
3	PAOZZ	5305009931848	96906	MS35207-265	.SCREW,MACHINE #10-32 X 3/4.....	12
					UOC:A15,B15,B16,H15,H16	
4	PAOZZ	5935012695994	19207	12341749	.CONNECTOR,RECEPTA.....	1
					UOC:A15,B15,B16,H15,H16	
5	XBOOO		34623	5594317	.PLUG ASSEMBLY.....	1
					UOC:A15,B15,B16,H15,H16	
6	PAOZZ	5935012827833	34623	5593599	..CONNECTOR,PLUG,ELEC.....	1
					UOC:A15,B15,B16,H15,H16	
7	PAOZZ	5975012997781	53421	T30MR-0	..STRAP,TIEDOWN,ELECT.....	1
					UOC:A15,B15,B16,H15,H16	
8	PAOZZ	9905012943356	34623	5594319	..PLATE,INSTRUCTION.....	1
					UOC:A15,B15,B16,H15,H16	
9	PAOZZ	5320000835009	11078	ADS43	.RIVET,BLIND 1/8.....	2
					UOC:A15,B15,B16,H15,H16	
10	PAOZZ	5920012700090	34623	12341726	.FUSEHOLDER,BLOCK.....	2
					UOC:A15,B15,B16,H15,H16	
11	PAOZZ	5310012349416	96906	MS51412-2	.WASHER,FLAT #10.....	8
					UOC:A15,B15,B16,H15,H16	
12	PAOZZ	5310012510726	34623	5593053	.NUT,SELF-LOCKING,HE #10-32.....	10
					UOC:A15,B15,B16,H15,H16	
13	PAOZZ	5920010850825	58536	AA55569/01-009	.FUSE,INCLOSED LINK 20 AMP.....	8
					UOC:A15,B15,B16,H15,H16	
14	PAOZZ	5305005435828	96906	MS35309-306	.SCREW,CAP,HEXAGON H 1/4-20 X 3/4..	1
					UOC:A15,B15,B16,H15,H16	
15	PFOZZ	5340012743021	19207	12340983	.STRAP,RETAINING.....	1
					UOC:A15,B15,B16,H15,H16	
16	PAOZZ	5310008551102	96906	MS35649-2255	.NUT,PLAIN,HEXAGON 1/4-20.....	1
					UOC:A15,B15,B16,H15,H16	
17	PAOZZ	5940009836105	81349	39TB10F	.TERMINAL BOARD.....	1
					UOC:A15,B15,B16,H15,H16	
18	PAOZZ	5945012664593	34623	5597249	.RELAY,ELECTROMAGNET.....	2
					UOC:A15,B15,B16,H15,H16	
19	PFOZZ	5935012698992	34623	5597248	.SOCKET,PLUG-IN ELEC.....	2
					UOC:A15,B15,B16,H15,H16	
20	XAOZZ		34623	5597593	.COVER ASSEMBLY.....	1
					UOC:A15,B15,B16,H15,H16	
21	PAOZZ	5305009846194	96906	MS35206-246	.SCREW,MACHINE #8-32 X 5/8.....	4
					UOC:A15,B15,B16,H15,H16	
22	PAOZZ	5310000453299	96906	MS35338-42	.WASHER,LOCK #8.....	4
					UOC:A15,B15,B16,H15,H16	
23	PAOZZ	5310009359021	96906	MS51943-35	.NUT,SELF-LOCKING,HE 3/8-16.....	1
					UOC:A15,B15,B16,H15,H16	
24	PAOZZ	5310006379541	96906	MS35338-46	.WASHER,LOCK 3/8.....	1

SECTION II			TM9-2320-280-24P			
(1)	(2)	(3)	(4)	(5)	(6)	(7)
ITEM	SMR			PART		
NO	CODE	NSN	CAGEC	NUMBER	DESCRIPTION AND USABLE ON CODES(UC)	QTY
25	PAOZZ	5310000877493	96906	MS27183-13	UOC:A15,B15,B16,H15,H16 .WASHER,FLAT 3/8.....	1
26	PFOZZ	5940012725800	19207	12341639	UOC:A15,B15,B16,H15,H16 .TERMINAL,STUD.....	1
27	PAOZZ	5305009906444	96906	MS35207-261	UOC:A15,B15,B16,H15,H16 .SCREW,MACHINE #10-32 X 3/8.....	2
28	PAOZZ	5305009897435	96906	MS35207-264	UOC:A15,B15,B16,H15,H16 .SCREW,MACHINE #10-32 X 5/8.....	2
29	PAOZZ	5305009897434	96906	MS35207-263	UOC:A15,B15,B16,H15,H16 .SCREW,MACHINE #10-32 X 1/2.....	8
30	PAOZZ	5930006159376	96906	MS35059-21	UOC:A15,B15,B16,H15,H16 .SWITCH,TOGGLE.....	1

END OF FIGURE

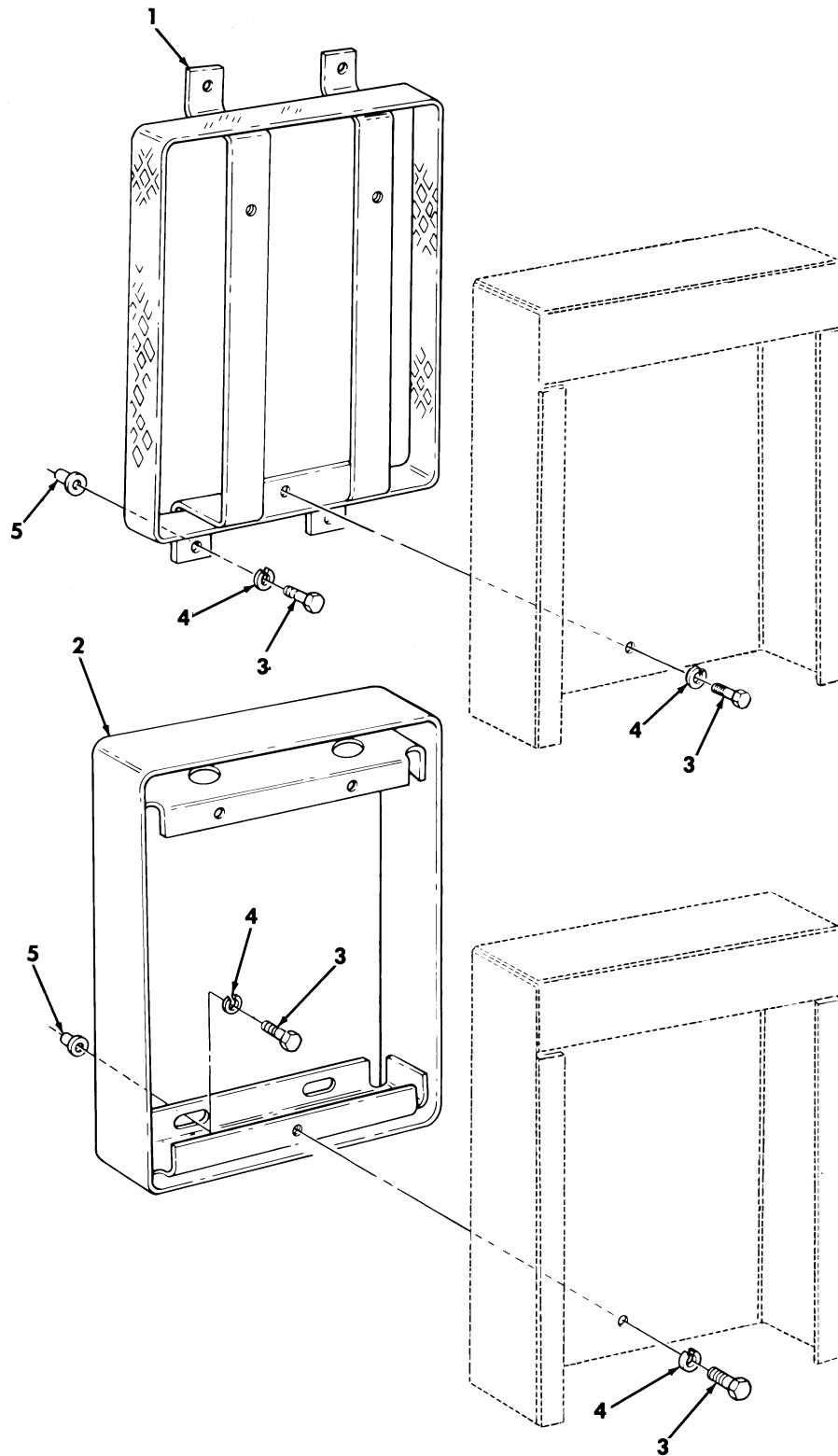

Figure 53. Control Box Assembly, M996, M996A1, M997, M997A1, and M997A2 Ambulance.

SECTION II			TM9-2320-280-24P			
(1)	(2)	(3)	(4)	(5)	(6)	(7)
ITEM	SMR			PART		
NO	CODE	NSN	CAGEC	NUMBER	DESCRIPTION AND USABLE ON CODES(UC)	QTY
GROUP 0608 MISCELLANEOUS ITEMS						
FIG. 53 CONTROL BOX ASSEMBLY,M996, M996A1,M997,M997A1,AND M997A2 AMBULANCE						
1	PFOZZ	5340012896216	34623	5598218	BRACKET,MOUNTING.....	1
					UOC:A15,B15,B16,H15,H16	
2	PFOZZ	5340012894475	34623	5598221	BRACKET,MOUNTING.....	1
					UOC:A15,B15,B16,H15,H16	
3	PAOZZ	5305000680502	96906	MS90725-6	SCREW,CAP,HEXAGON H 1/4-20 X .75...	14
					UOC:A15,B15,B16,H15,H16	
4	PAOZZ	5310005825965	96906	MS35338-44	WASHER,LOCK 1/4.....	14
					UOC:A15,B15,B16,H15,H16	
5	PAOZZ	5310011981722	34623	5982526	NUT,PLAIN,BLIND RIV 1/4-20.....	8
					UOC:A15,B15,B16,H15,H16	

END OF FIGURE

1 —  
2  
thru  
13

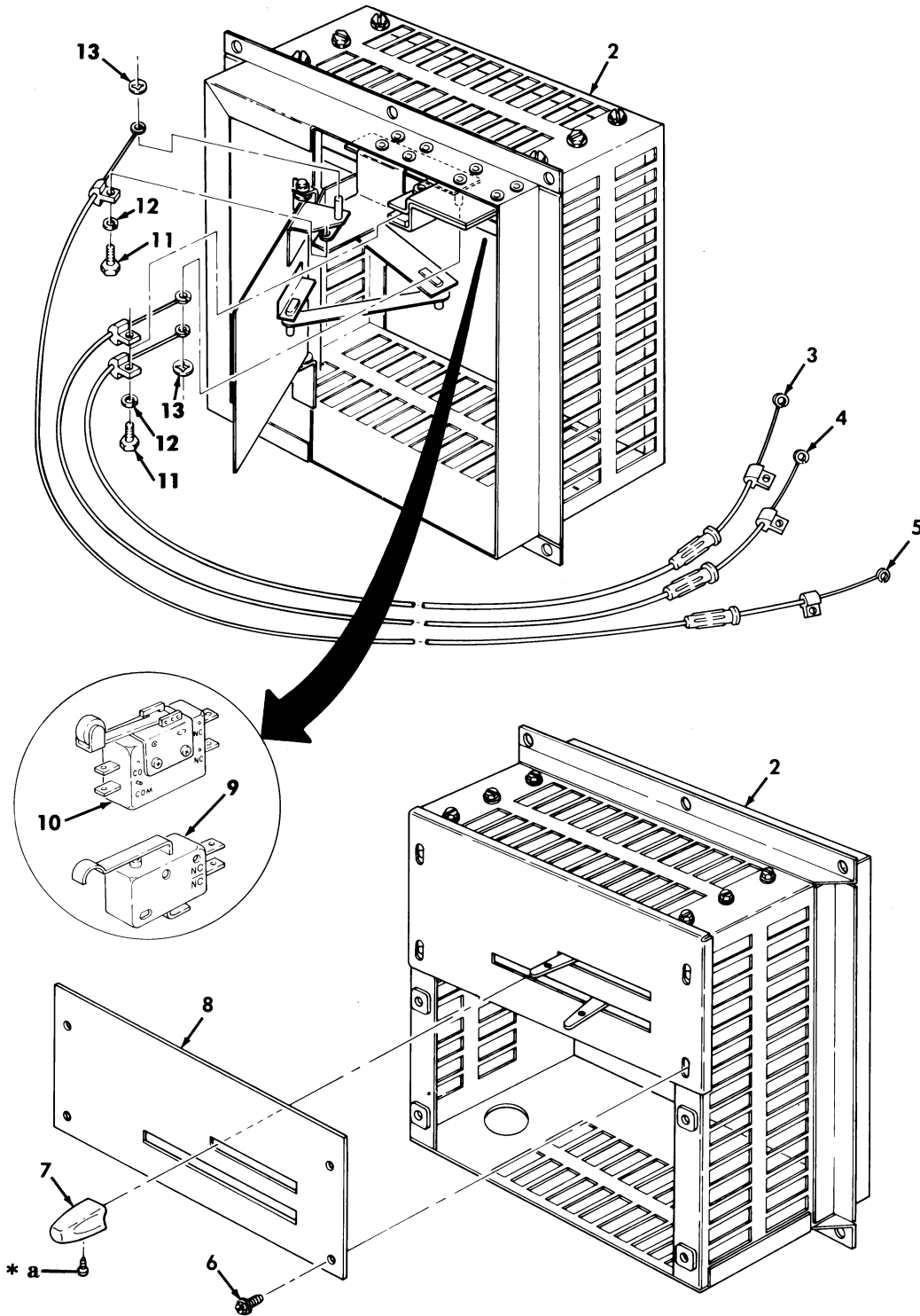

Figure 54. Air Conditioner and Heater Control Box, M997, M997A1, and M997A2 Ambulance.

SECTION II			TM9-2320-280-24P			
(1)	(2)	(3)	(4)	(5)	(6)	(7)
ITEM NO	SMR CODE	NSN	CAGEC	PART NUMBER	DESCRIPTION AND USABLE ON CODES(UOC)	QTY
GROUP 0608 MISCELLANEOUS ITEMS						
FIG. 54 AIR CONDITIONER AND HEATER CONTROL BOX,M997,M997A1,AND M997A2 AMBULANCE						
1	PAOOO	2540012653234	24234	410913	CONTROL BOX,ELECTRI.....	1
					UOC:A15,B15,H15	
2	XAOZZ		24234	513448	.CONTROL BOX.....	1
					UOC:A15,B15,H15	
3	PAOZZ	2590012765071	24234	243047	.CONTROL ASSEMBLY,PU.....	1
					UOC:A15,B15,H15	
4	PAOZZ	6150012767698	24234	243046	.CABLE ASSEMBLY,SPEC.....	1
					UOC:A15,B15,H15	
5	PAOZZ	2990014068738	24234	243048	.CONTROL ASSEMBLY,PU.....	1
					UOC:A15,B15,H15	
6	PAOZZ	5305009897434	96906	MS35207-263	.SCREW,MACHINE #10-32 X 1/2.....	4
					UOC:A15,B15,H15	
7	PAOZZ	5355011674114	99688	58668	.KNOB.....	2
					UOC:A15,B15,H15	
8	PFOZZ	2510012765058	24234	410915	.PANEL,VEHICULAR OPE.....	1
					UOC:A15,B15,H15	
9	PFOZZ	5930011901231	99688	65171	.SWITCH,SENSITIVE.....	2
					UOC:A15,B15,H15	
10	PAOZZ	5930013113610	24234	410914 ITEM 8	.SWITCH,INTERLOCK.....	1
					UOC:A15,B15,H15	
11	PAOZZ	5305009931848	96906	MS35207-265	.SCREW,MACHINE #10-32 X 3/4.....	2
					UOC:A15,B15,H15	
12	PAOZZ	5310000453296	96906	MS35338-43	.WASHER,LOCK #10.....	2
					UOC:A15,B15,H15	
13	PAOZZ	5310011617308	99688	62229	.PUSH ON NUT 3/16.....	2
					UOC:A15,B15,H15	

END OF FIGURE



1 — 2  
thru  
22

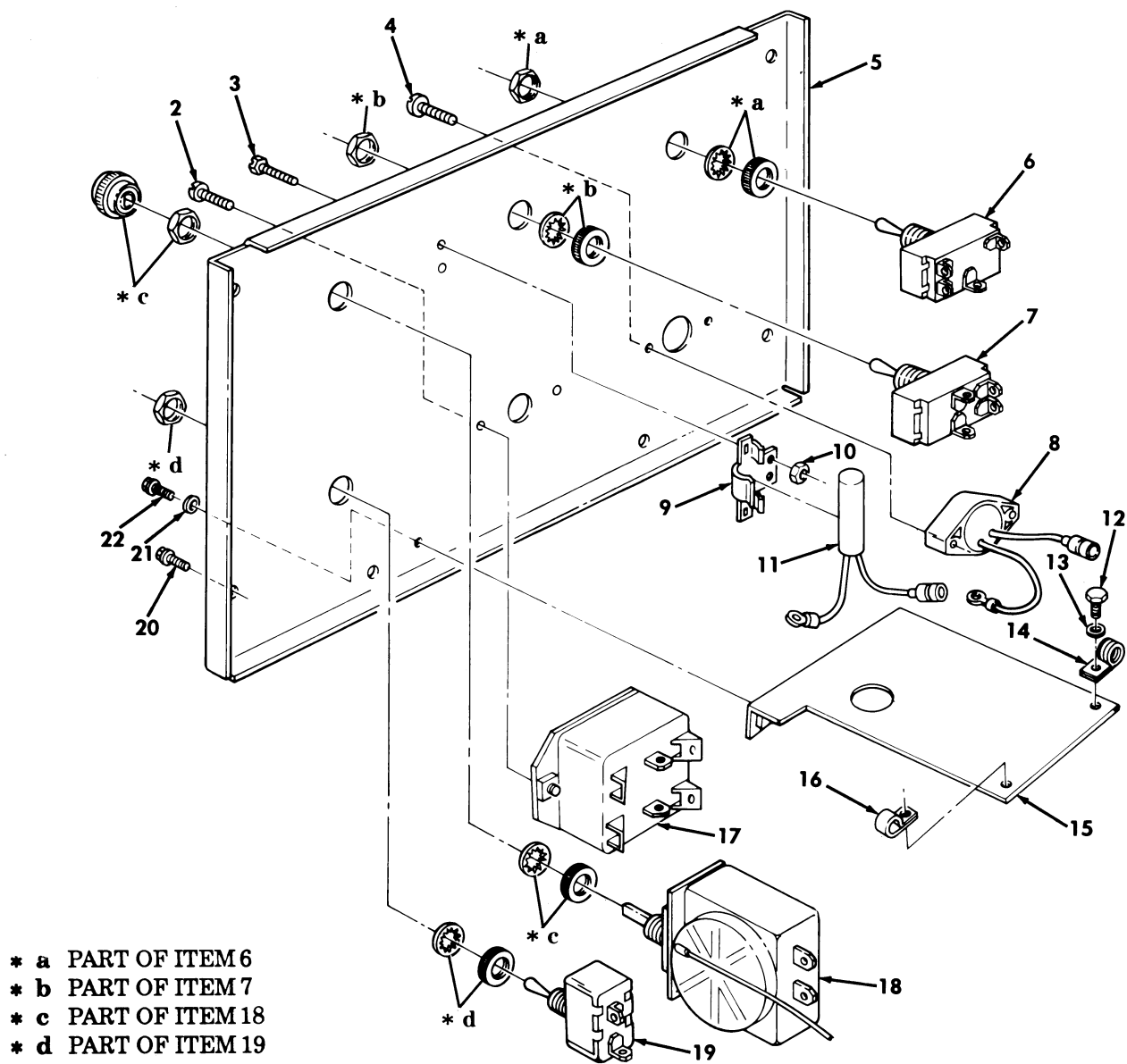

Figure 55. Personnel Heater/Vent and A/C Control Panel, M997, M997A1, and M997A2 Ambulance.

SECTION II			TM9-2320-280-24P			
(1)	(2)	(3)	(4)	(5)	(6)	(7)
ITEM NO	SMR CODE	NSN	CAGEC	PART NUMBER	DESCRIPTION AND USABLE ON CODES(UOC)	QTY
GROUP 0608 MISCELLANEOUS ITEMS						
FIG. 55 PERSONNEL HEATER/VENT AND A/C CONTROL PANEL,M997,M997A1,AND M997A2 AMBULANCE						
1	PFOOO	2510012765058	24234	410915	PANEL,VEHICULAR OPE.....	1
					UOC:A15,B15,H15	
2	PAOZZ	5305009844983	96906	MS35206-226	.SCREW,MACHINE #6-32 X 1/4.....	2
					UOC:A15,B15,H15	
3	PAOZZ	5305009844976	96906	MS35206-219	.SCREW,MACHINE #4-40 X 3/4.....	2
					UOC:A15,B15,H15	
4	PAOZZ	5305012506584	7X677	167038	.SCREW,TAPPING #6-32 X 3/8.....	2
					UOC:A15,B15,H15	
5	XAOZZ		24234	513409	.PANEL.....	1
					UOC:A15,B15,H15	
6	PAOZZ	5930004459274	96906	MS27407-4	.SWITCH,TOGGLE.....	1
					UOC:A15,B15,H15	
7	PAOZA	5930011636256	99688	65140	.SWITCH,TOGGLE.....	1
					UOC:A15,B15,H15	
8	PAOZZ	6220012697067	19207	12341838	.LIGHT,INDICATOR.....	1
					UOC:A15,B15,H15	
9	PFOZZ	5340012702681	24234	513310	.BRACKET,MOUNTING.....	1
					UOC:A15,B15,H15	
10	PAOZZ	5310008892543	96906	MS21045-04	.NUT,SELF-LOCKING,HE #4-40.....	2
					UOC:A15,B15,H15	
11	PAOZZ	5930012664592	34623	5597738	.SWITCH,TILT.....	1
					UOC:A15,B15,H15	
12	PAOZZ	5305000712506	80204	B1821BH025C050N	.SCREW,CAP,HEXAGON H 1/4-20 X .50..	2
					UOC:A15,B15,H15	
13	PAOZZ	5310002090786	96906	MS35335-33	.WASHER,LOCK 1/4.....	2
					UOC:A15,B15,H15	
14	XBOZZ		24234	290081	.CLAMP,HOSE.....	1
					UOC:A15,B15,H15	
15	PAOZZ	5340012886551	24234	513444	.BRACKET,MOUNTING.....	1
					UOC:A15,B15,H15	
16	PAOZZ	5340000913790	96906	MS21333-72	.CLAMP,LOOP 5/8.....	1
					UOC:A15,B15,H15	
17	PAOZZ	5930009788805	96906	MS25307-312	.SWITCH,TOGGLE.....	1
					UOC:A15,B15,H15	
18	PAOZZ	5930011651657	99688	65139	.SWITCH,THERMOSTATIC.....	1
					UOC:A15,B15,H15	
19	PAOZZ	5930007284328	96906	MS25306-222	.SWITCH,TOGGLE.....	1
					UOC:A15,B15,H15	
20	PAOZZ	5305009897434	96906	MS35207-263	.SCREW,MACHINE #10-32 X .50.....	4
					UOC:A15,B15,H15	
21	PAOZZ	5310000453296	96906	MS35338-43	.WASHER,LOCK #10.....	2
					UOC:A15,B15,H15	
22	PAOZZ	5305009931848	96906	MS35207-265	.SCREW,MACHINE #10-32 X .75.....	2
					UOC:A15,B15,H15	

END OF FIGURE

1 — 2  
thru  
25

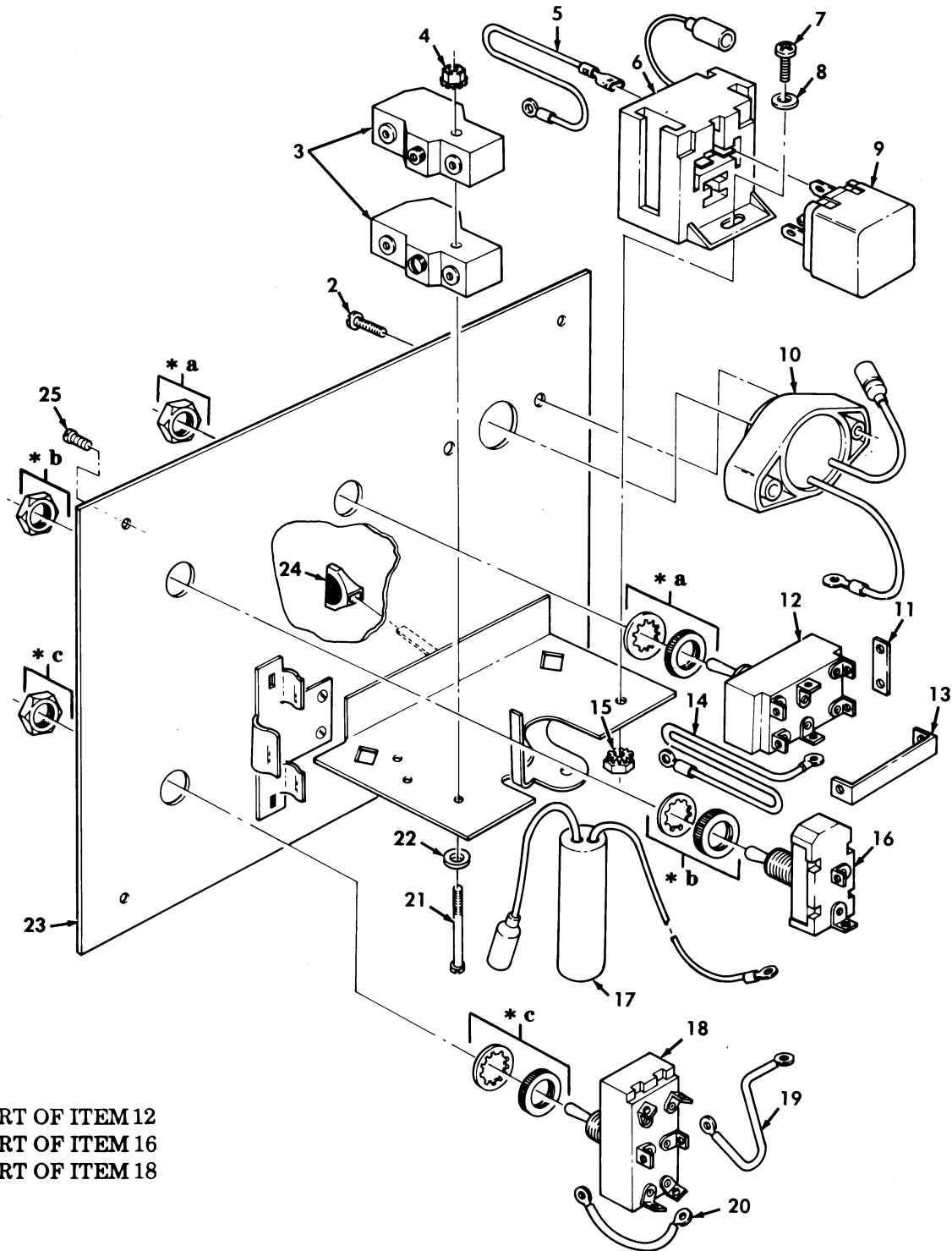

Figure 56. Personnel Heater/Vent and A/C Control Panels, M996 and M996A1 Ambulance.

SECTION II			TM9-2320-280-24P			
(1)	(2)	(3)	(4)	(5)	(6)	(7)
ITEM	SMR			PART		
NO	CODE	NSN	CAGEC	NUMBER	DESCRIPTION AND USABLE ON CODES(UOC)	QTY
GROUP 0608 MISCELLANEOUS ITEMS						
FIG. 56 PERSONNEL HEATER/VENT AND A/C CONTROL PANEL,M996 AND M996A1 AMBULANCE						
1	PAOOO	2540012856087	34623	5597737	CONTROL BOX,ELECTRI.....	1
					UOC:B16,H16	
2	PAOZZ	5305012506584	7X677	167038	.SCREW,TAPPING #6-32 X 3/8.....	2
					UOC:B16,H16	
3	XBOZZ		80138	256A	.SWITCH,TOGGLE.....	2
					UOC:B16,H16	
4	PAOZZ	5310012721356	34623	G-00271482	.NUT,PLAIN,EXTENDED #6-32.....	2
					UOC:B16,H16	
5	PFOZZ	6150012691859	19207	12341616	.LEAD,ELECTRICAL.....	1
					UOC:B16,H16	
6	PFOZZ	5935012698992	34623	5597248	.SOCKET,PLUG-IN ELEC.....	1
					UOC:B16,H16	
7	PAOZZ	5305009897434	96906	MS35207-263	.SCREW,MACHINE #10-32 X 1/2.....	1
					UOC:B16,H16	
8	PAOZZ	5310012349416	96906	MS51412-2	.WASHER,FLAT #10.....	1
					UOC:B16,H16	
9	PAOZZ	5945012664593	34623	5597249	.RELAY,ELECTROMAGNET 24 VOLTS.....	1
					UOC:B16,H16	
10	PAOZZ	6220012697067	19207	12341838	.LIGHT,INDICATOR.....	1
					UOC:B16,H16	
11	PFOZA	5935007904614	19207	7951748	.PLATE,RETAINING,ELE.....	1
					UOC:B16,H16	
12	PAOZZ	5930009788805	96906	MS25307-312	.SWITCH,TOGGLE.....	1
					UOC:B16,H16	
13	PFOZZ	2540000398258	57733	G488213	.JUMPER ASSEMBLY.....	1
					UOC:B16,H16	
14	PAOZZ	6150014738640	34623	5593479	.LEAD ASSEMBLY,ELECT.....	1
					UOC:B16,H16	
15	PAOZZ	5310012510726	34623	5593053	.NUT,SELF-LOCKING,HE #10-32.....	1
					UOC:B16,H16	
16	PAOZZ	5930007284328	96906	MS25306-222	.SWITCH,TOGGLE.....	1
					UOC:B16,H16	
17	PAOZZ	5930012664592	34623	5597738	.SWITCH,TILT.....	1
					UOC:B16,H16	
18	PAOZZ	5930004459274	96906	MS27407-4	.SWITCH,TOGGLE.....	1
					UOC:B16,H16	
19	PFOZZ	6150012691861	19207	12341615-1	.LEAD,ELECTRICAL.....	1
					UOC:B16,H16	
20	PFOZZ	6150012691862	19207	12341615-3	.LEAD,ELECTRICAL.....	1
					UOC:B16,H16	
21	PAOZZ	5305001503408	96906	MS35206-329	.SCREW,MACHINE #6-32 X 1-3/4.....	2
					UOC:B16,H16	
22	PAOZZ	5310000454007	96906	MS35338-41	.WASHER,LOCK #6.....	2
					UOC:B16,H16	
23	XAOZZ		34623	5597736	.PANEL.....	1
					UOC:B16,H16	
24	PFOZZ	5355012725824	34623	5598117	.KNOB.....	1

SECTION II			TM9-2320-280-24P			
(1)	(2)	(3)	(4)	(5)	(6)	(7)
ITEM	SMR			PART		
NO	CODE	NSN	CAGEC	NUMBER	DESCRIPTION AND USABLE ON CODES(UC)	QTY
25	PAOZZ	5305012729042	34623	5593409	UOC:B16,H16 .SCREW,CAP,HEXAGON H #10-32 X 3/4..	4
					UOC:B16,H16	

END OF FIGURE

4 — 

5 thru 7
----------------

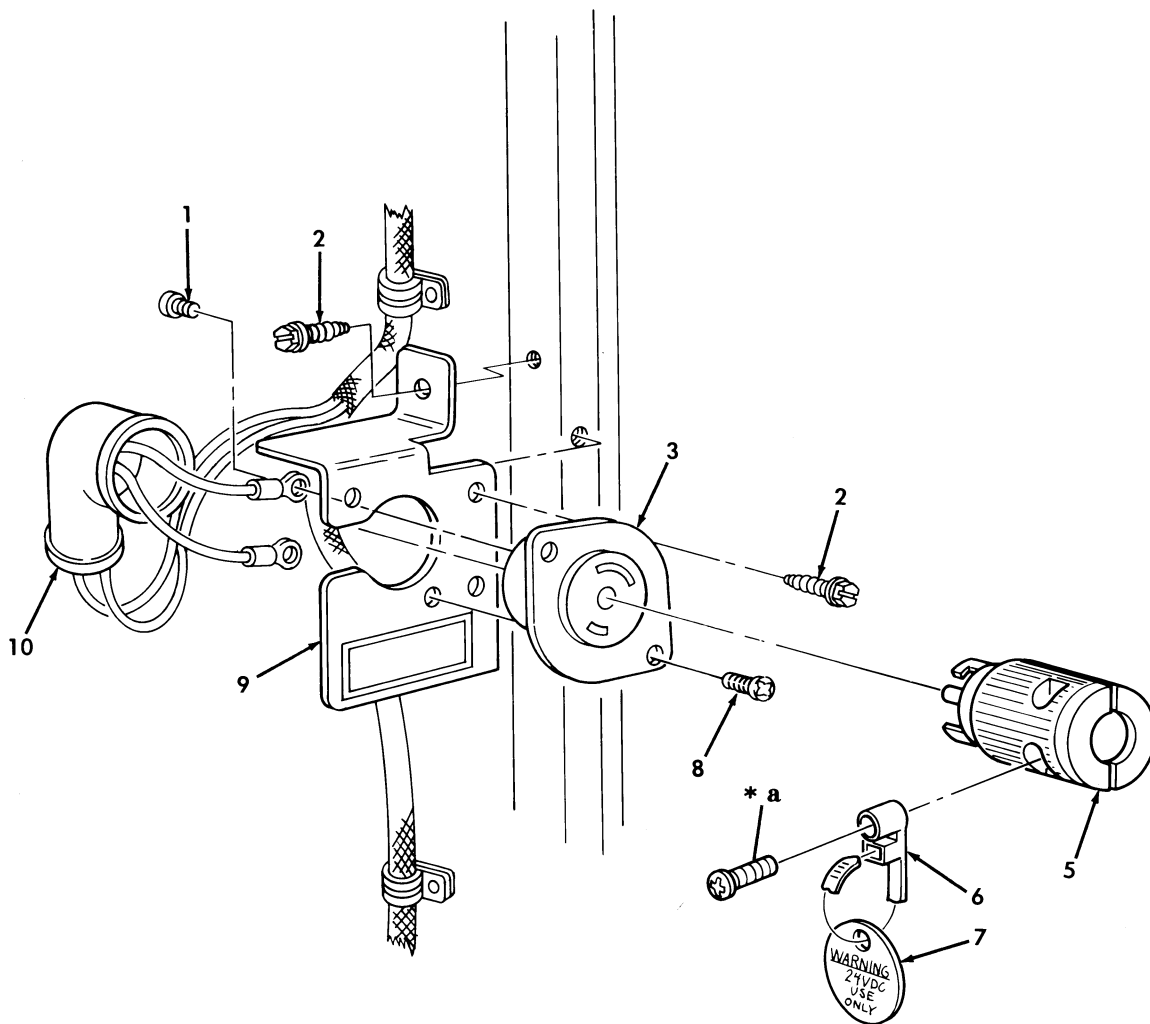

\* a PART OF ITEM 4

Figure 57. 24V DC Outlet, Rear, M996, M996A1, M997, M997A1, and M997A2 Ambulance.

SECTION II			TM9-2320-280-24P			
(1)	(2)	(3)	(4)	(5)	(6)	(7)
ITEM	SMR			PART		
NO	CODE	NSN	CAGEC	NUMBER	DESCRIPTION AND USABLE ON CODES(UC)	QTY
GROUP 0608 MISCELLANEOUS ITEMS						
FIG. 57 24V DC OUTLET, REAR, M996, M996A1, M997, M997A1, AND M997A2 AMBULANCE						
1	PAOZZ	5305012764870	74545	Y-11296	SCREW, EXTERNALLY RE.....	2
					UOC:A15, B15, B16, H15, H16	
2	PAOZZ	5305012729042	34623	5593409	SCREW, CAP, HEXAGON H #10-32 X 3/4...	3
					UOC:A15, B15, B16, H15, H16	
3	PAOZZ	5935012695994	19207	12341749	CONNECTOR, RECEPTACL.....	1
					UOC:A15, B15, B16, H15, H16	
4	XBOOO		34623	5594317	PLUG ASSEMBLY.....	1
					UOC:A15, B15, B16, H15, H16	
5	PAOZZ	5935012827833	34623	5593599	.CONNECTOR, PLUG, ELEC.....	1
					UOC:A15, B15, B16, H15, H16	
6	PAOZZ	5975012997781	53421	T30MR-0	.STRAP, TIEDOWN, ELECT.....	1
					UOC:A15, B15, B16, H15, H16	
7	PAOZZ	9905012943356	34623	5594319	.PLATE, INSTRUCTION.....	1
					UOC:A15, B15, B16, H15, H16	
8	PAOZZ	5305012506582	34623	5592819	SCREW, TAPPING #6-32 X 3/8.....	2
					UOC:A15, B15, B16, H15, H16	
9	PFOZZ	5340012734668	34623	5597267	BRACKET, MOUNTING.....	1
					UOC:A15, B15, B16, H15, H16	
10	PFOZZ	5975012808922	7Z043	5501	CABLE NIPPLE, ELECTR.....	1
					UOC:A15, B15, B16, H15, H16	

END OF FIGURE

4-5

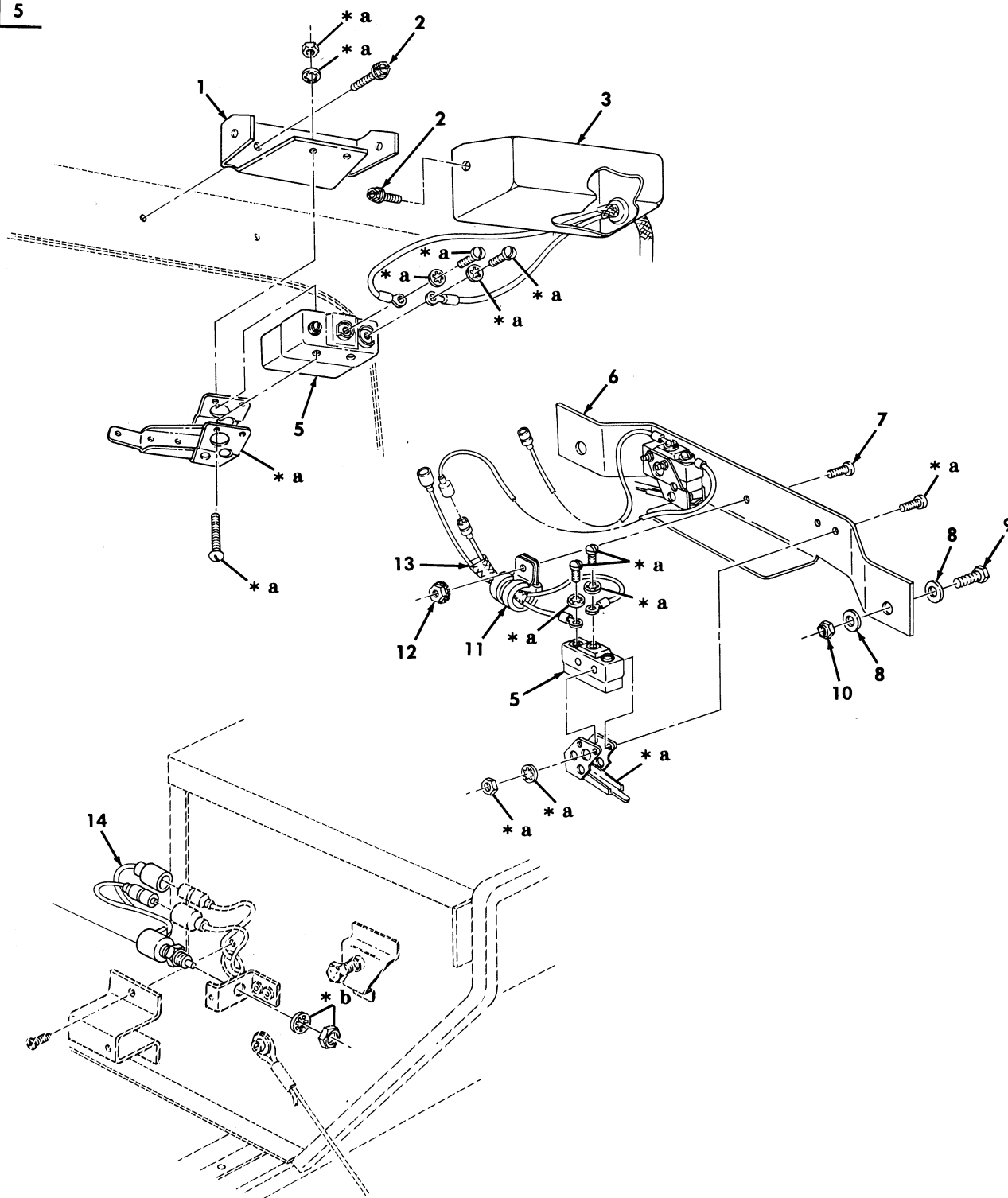

- \* a PART OF ITEM 4
- \* b PART OF ITEM 14

Figure 58. Front and Rear Blackout Switches, M996, M996A1, M997, M997A1, and M997A2 Ambulance.



SECTION II			TM9-2320-280-24P			
(1)	(2)	(3)	(4)	(5)	(6)	(7)
ITEM NO	SMR CODE	NSN	CAGEC	PART NUMBER	DESCRIPTION AND USABLE ON CODES(UOC)	QTY
GROUP 0608 MISCELLANEOUS ITEMS						
FIG. 58 FRONT AND REAR BLACKOUT SWITCHES, M996, M996A1, M997, M997A1, AND M997A2 AMBULANCE						
1	PFOZZ	5340012725595	34623	5598046	BRACKET, MOUNTING.....	1
					UOC: A15, B15, B16, H15, H16	
2	PAOZZ	5305012596322	34623	12342499-1	SCREW, MACHINE #10-32 X 1/2.....	4
					UOC: A15, B15, B16, H15, H16	
3	PFOZZ	5975012704587	19207	12341467	JUNCTION BOX.....	1
					UOC: A15, B15, B16, H15, H16	
4	PFOZZ	5930012663919	34623	5598011	SWITCH, SENSITIVE.....	3
					UOC: A15, B15, B16, H15, H16	
5	PFOZA	5930012876698	34623	12341751	. SWITCH, SENSITIVE.....	1
					UOC: A15, B15, B16, H15, H16	
6	PFOZZ	5340012723389	34623	5597988	BRACKET, MOUNTING.....	1
					UOC: A15, B15, B16, H15, H16	
7	PAOZZ	5305009953444	96906	MS35207-266	SCREW, MACHINE #10-32 X 5/8.....	2
					UOC: A15, B15, B16, H15, H16	
8	PFOZZ	5310012510748	34623	5593691	WASHER, FLAT 1/4.....	4
					UOC: A15, B15, B16, H15, H16	
9	PFOZZ	5305000680502	96906	MS90725-6	SCREW, CAP, HEXAGON H 1/4-20 X 3/4...	2
					UOC: A15, B15, B16, H15, H16	
10	PFOZZ	5310012552695	34623	5593035	NUT, SELF-LOCKING, HE 1/4-20.....	2
					UOC: A15, B15, B16, H15, H16	
11	PAOZZ	5340009226300	96906	MS21333-77	CLAMP, LOOP.....	1
					UOC: A15, B15, B16, H15, H16	
12	PAOZZ	5310012510726	34623	5593053	NUT, SELF-LOCKING, HE #10-32.....	1
					UOC: A15, B15, B16, H15, H16	
13	PFOZZ	6150012691840	19207	12341408	CABLE ASSEMBLY, SPEC.....	2
					UOC: A15, B15, B16, H15, H16	
14	PAOZZ	5930012661811	19207	12340927	SWITCH, SENSITIVE.....	1
					UOC: A15, B15, B16, H15, H16	

END OF FIGURE

1 — 2 thru 26

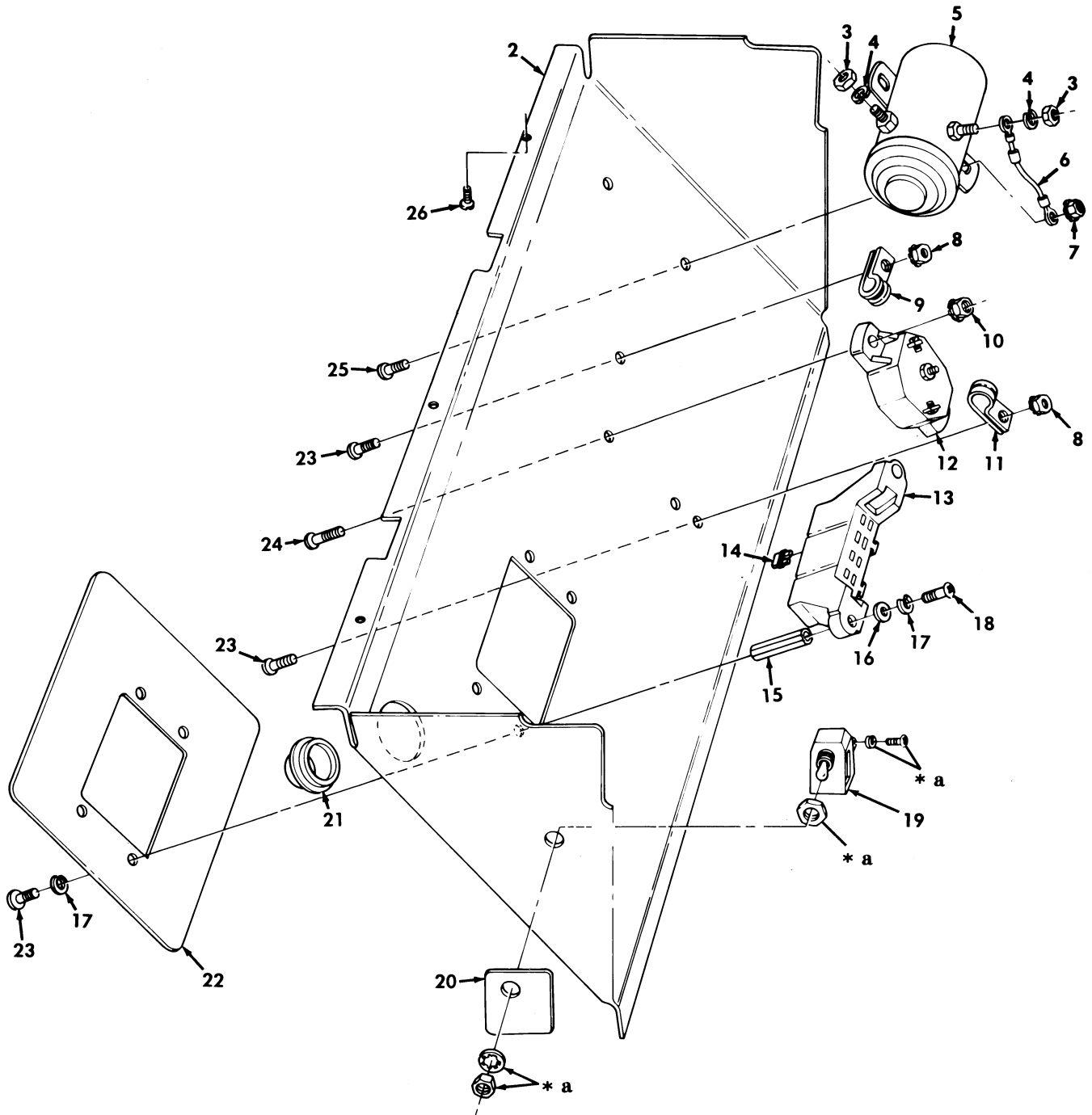

\* a PART OF ITEM 19

Figure 59. NBC Control Panel, M996, M996A1, M997, M997A1, and M997A2 Ambulance.

SECTION II			TM9-2320-280-24P			
(1)	(2)	(3)	(4)	(5)	(6)	(7)
ITEM	SMR			PART		
NO	CODE	NSN	CAGEC	NUMBER	DESCRIPTION AND USABLE ON CODES(UOC)	QTY
GROUP 0608 MISCELLANEOUS ITEMS						
FIG. 59 NBC CONTROL PANEL,M996, M996A1,M997,M997A1,AND M997A2 AMBULANCE						
1	A0000		34623	5597601	PANEL ASSEMBLY.....	1
					UOC:B16,H16	
1	A0000		34623	5597197	CONTROL PANEL.....	1
					UOC:A15,B15,H15	
2	PAOZZ	5975012708546	34623	5598130	.PANEL,BLANK.....	1
					UOC:A15,B15,B16,H15,H16	
3	PAOZZ	5310009054600	96906	MS51968-6	.NUT,PLAIN,HEXAGON 5/16-24.....	2
					UOC:A15,B15,B16,H15,H16	
4	PAOZZ	5310004079566	96906	MS35338-45	.WASHER,LOCK 5/16.....	2
					UOC:A15,B15,B16,H15,H16	
5	PFOZZ	5945012661810	19207	12341416	.RELAY,ELECTROMAGNET.....	1
					UOC:A15,B15,B16,H15,H16	
6	PFOZZ	5961012663984	19207	12341840	.SEMICONDUCTOR DEVIC.....	1
					UOC:A15,B15,B16,H15,H16	
7	PAOZZ	5310012522999	34623	5593033	.NUT,SELF-LOCKING,AS 1/4-20.....	2
					UOC:A15,B15,B16,H15,H16	
8	PAOZZ	5310012510726	34623	5593053	.NUT,SELF-LOCKING,HE #10-32.....	3
					UOC:A15,B15,B16,H15,H16	
9	PFOZZ	5340007247038	96906	MS21333-76	.CLAMP,LOOP.....	1
					UOC:A15,B15,H15	
9	PFOZZ	5340000502740	96906	MS21333-75	.CLAMP,LOOP.....	1
					UOC:B16,H16	
10	PAOZZ	5310012506587	34623	5592998	.NUT #8-32.....	2
					UOC:A15,B15,B16,H15,H16	
11	PFOZZ	5340009226300	96906	MS21333-77	.CLAMP,LOOP.....	1
					UOC:A15,B15,B16,H15,H16	
12	PAOZZ	5905002586788	12436	667201-011	.RESISTOR,VOLTAGE SE.....	1
					UOC:A15,B15,B16,H15,H16	
13	PFOZZ	5920012700090	34623	12341726	.FUSEHOLDER,BLOCK.....	2
					UOC:A15,B15,B16,H15,H16	
14	PAOZZ	5920010850825	58536	AA55569/01-009	.FUSE,INCLOSED LINK 20 AMP.....	8
					UOC:A15,B15,B16,H15,H16	
15	PFOZZ	5340012482878	80205	NAS1831A6E28	.POST,ELECTRICAL-MEC.....	4
					UOC:A15,B15,B16,H15,H16	
16	PAOZZ	5310012349416	96906	MS51412-2	.WASHER,FLAT #10.....	4
					UOC:A15,B15,B16,H15,H16	
17	PAOZZ	5310000453296	96906	MS35338-43	.WASHER,LOCK #10.....	8
					UOC:A15,B15,B16,H15,H16	
18	PAOZZ	5305009931848	96906	MS35207-265	.SCREW,MACHINE #10-32 X 3/4.....	4
					UOC:A15,B15,B16,H15,H16	
19	PAOZZ	5930007363539	13445	5582	.SWITCH,TOGGLE.....	1
					UOC:A15,B15,B16,H15,H16	
20	PFOZZ	7690012665706	19207	12341326	.MARKER,IDENTIFICATI.....	1
					UOC:A15,B15,B16,H15,H16	
21	PAOZZ	5340012732380	28520	2723	.PLUG,PROTECTIVE,DUS.....	1
					UOC:A15,B15,B16,H15,H16	
22	PFOZZ	9905012651131	19207	12341622	.PLATE,IDENTIFICATIO.....	1

SECTION II			TM9-2320-280-24P			
(1)	(2)	(3)	(4)	(5)	(6)	(7)
ITEM	SMR			PART		
NO	CODE	NSN	CAGEC	NUMBER	DESCRIPTION AND USABLE ON CODES(UC)	QTY
22	PFOZZ	9905012651132	19207	12341621	UOC:A15,B15,H15 .PLATE,IDENTIFICATIO.....	1
23	PAOZZ	5305000593660	96906	MS51958-64	UOC:B16,H16 .SCREW,MACHINE #10-32 X 5/8.....	6
23	PAOZZ	5305009897434	96906	MS35207-263	UOC:A15,B16,H16 .SCREW,MACHINE #10-32 X 1/2.....	6
24	PAOZZ	5305009846194	96906	MS35206-246	UOC:B16,H16 .SCREW,MACHINE #8-32 X 5/8.....	2
25	PAOZZ	5305009881725	96906	MS35206-281	UOC:A15,B15,B16,H15,H16 .SCREW,MACHINE 1/4-20 X 3/4.....	2
26	PAOZZ	5305012596322	34623	12342499-1	UOC:A15,B15,B16,H15,H16 .SCREW,MACHINE #10-32 X 1/2.....	6

END OF FIGURE

4 — 5  
thru  
10

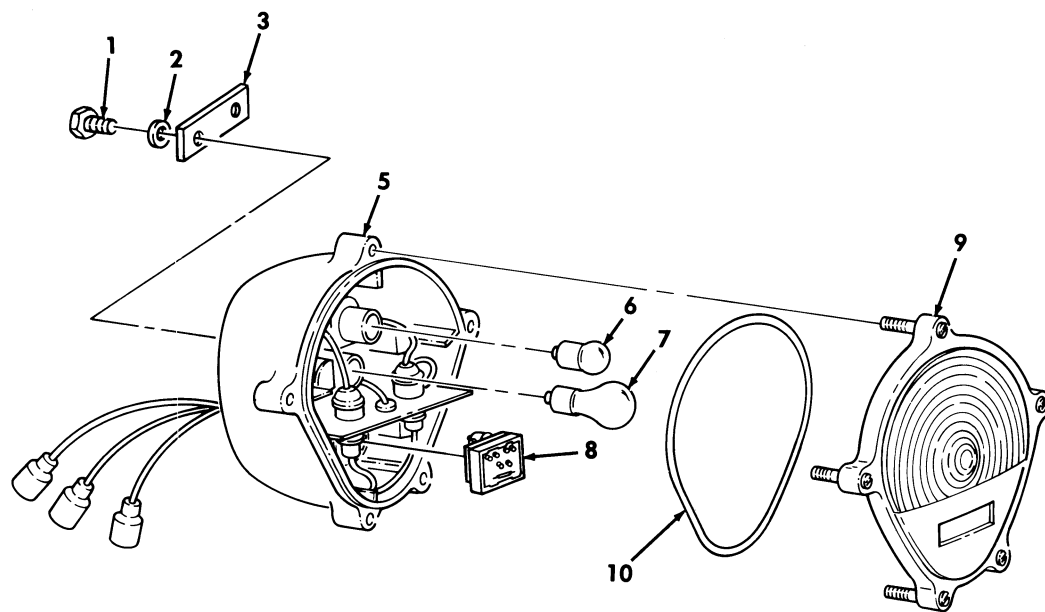

Figure 60. Front Composite Light and Mounting Hardware.

SECTION II			TM9-2320-280-24P			
(1)	(2)	(3)	(4)	(5)	(6)	(7)
ITEM	SMR			PART		
NO	CODE	NSN	CAGEC	NUMBER	DESCRIPTION AND USABLE ON CODES(UOC)	QTY
GROUP 0609 LIGHTS						
FIG. 60 FRONT COMPOSITE LIGHT AND MOUNTING HARDWARE						
1	PAOZZ	5305005434372	80204	B1821BH038C075N	SCREW,CAP,HEXAGON H 3/8-16 X .75...	4
2	PAOZZ	5310000877493	96906	MS27183-13	WASHER,FLAT 3/8.....	4
3	PAOZZ	5340011837233	19207	12338608	PLATE,MOUNTING.....	2
4	PAOOO	6220008801624	19207	11614156	LIGHT,PARKING.....	2
5	XDOZZ		19207	11639541	.BODY ASSEMBLY.....	1
6	PAOZZ	6240000193093	11083	2D1959	.LAMP,INCANDESCENT.....	1
7	PAOZZ	6240000446914	58536	A52463-2-10	.LAMP,INCANDESCENT.....	1
8	PAOZZ	5961013058848	19207	12360865	.SEMICONDUCTOR DEVIC.....	1
9	PAOZZ	6220001794325	19207	11639546	.LENS,LIGHT.....	1
10	PFOZZ	5331004630200	19207	11639519-1	.O-RING.....	1

END OF FIGURE

4 — 5  
thru  
11

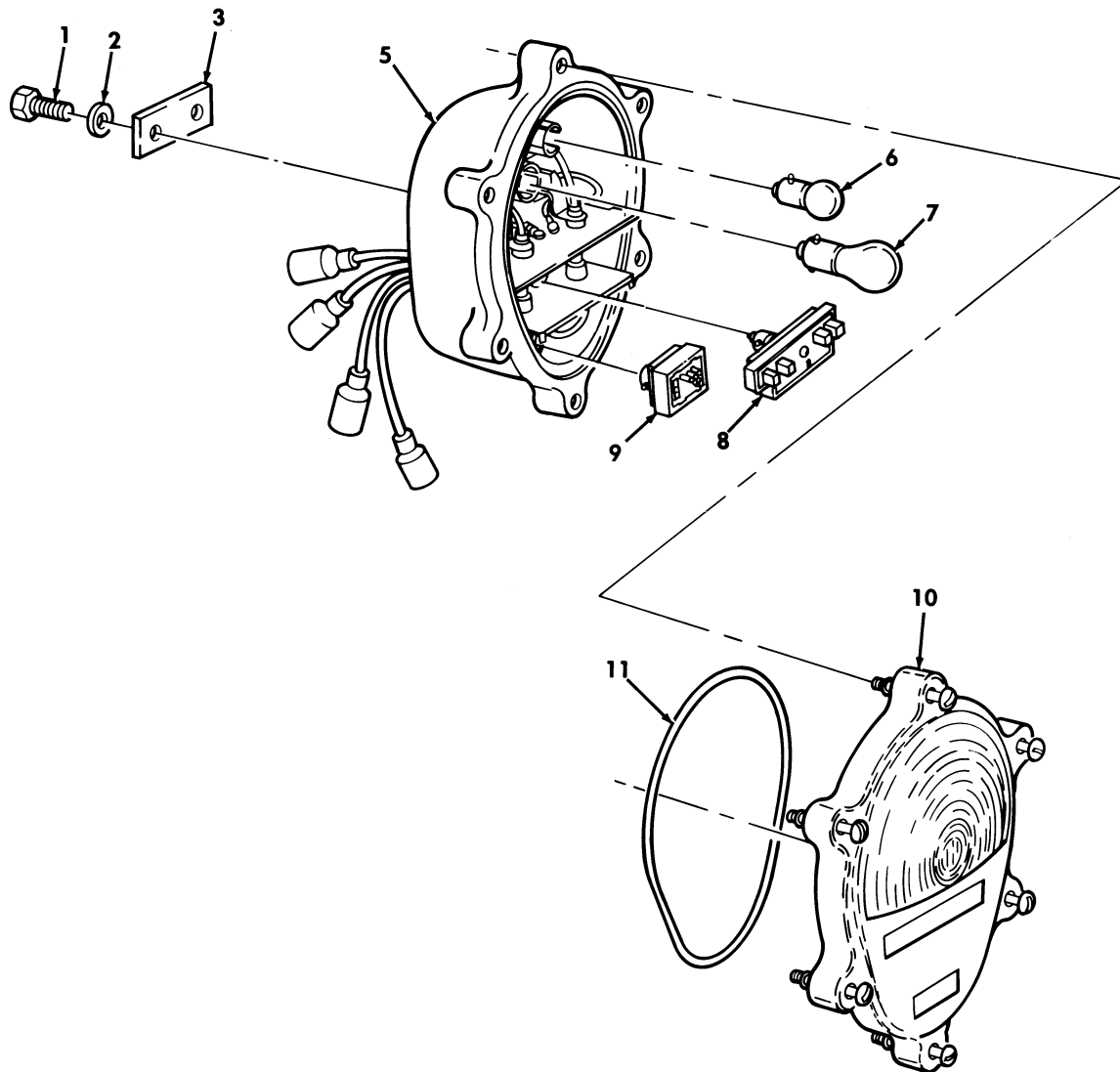

Figure 61. Rear Composite Light and Mounting Hardware.

SECTION II			TM9-2320-280-24P			
(1)	(2)	(3)	(4)	(5)	(6)	(7)
ITEM	SMR			PART		
NO	CODE	NSN	CAGEC	NUMBER	DESCRIPTION AND USABLE ON CODES(UOC)	QTY
GROUP 0609 LIGHTS						
FIG. 61 REAR COMPOSITE LIGHT AND MOUNTING HARDWARE						
1	PAOZZ	5305005434372	80204	B1821BH038C075N	SCREW,CAP,HEXAGON H 3/8-16 X 3/4...	4
2	PAOZZ	5310000877493	96906	MS27183-13	WASHER,FLAT 3/8.....	4
3	PAOZZ	5340011837233	19207	12338608	PLATE,MOUNTING.....	2
4	PAOOO	6220013723883	19207	12375837	TAILLIGHT,VEHICULAR.....	2
5	XAOZZ		19207	12375838	.BODY ASSEMBLY.....	1
6	PAOZZ	6240000193093	11083	2D1959	.LAMP,INCANDESCENT.....	1
7	PAOZZ	6240000446914	58536	A52463-2-10	.LAMP,INCANDESCENT.....	1
8	PAOZZ	6220012842709	19207	12360850-1	.LIGHT,MARKER,CLEARA.....	2
9	PAOZZ	6220012973217	19207	12360870-2	.STOP LIGHT,VEHICULA.....	1
10	PAOZZ	6220013592870	19207	12375841	.LENS,LIGHT.....	1
11	PAOZZ	5331004620907	19207	11639519-2	.O-RING.....	1

END OF FIGURE



Section II.

TM 9-2320-280-24P-1

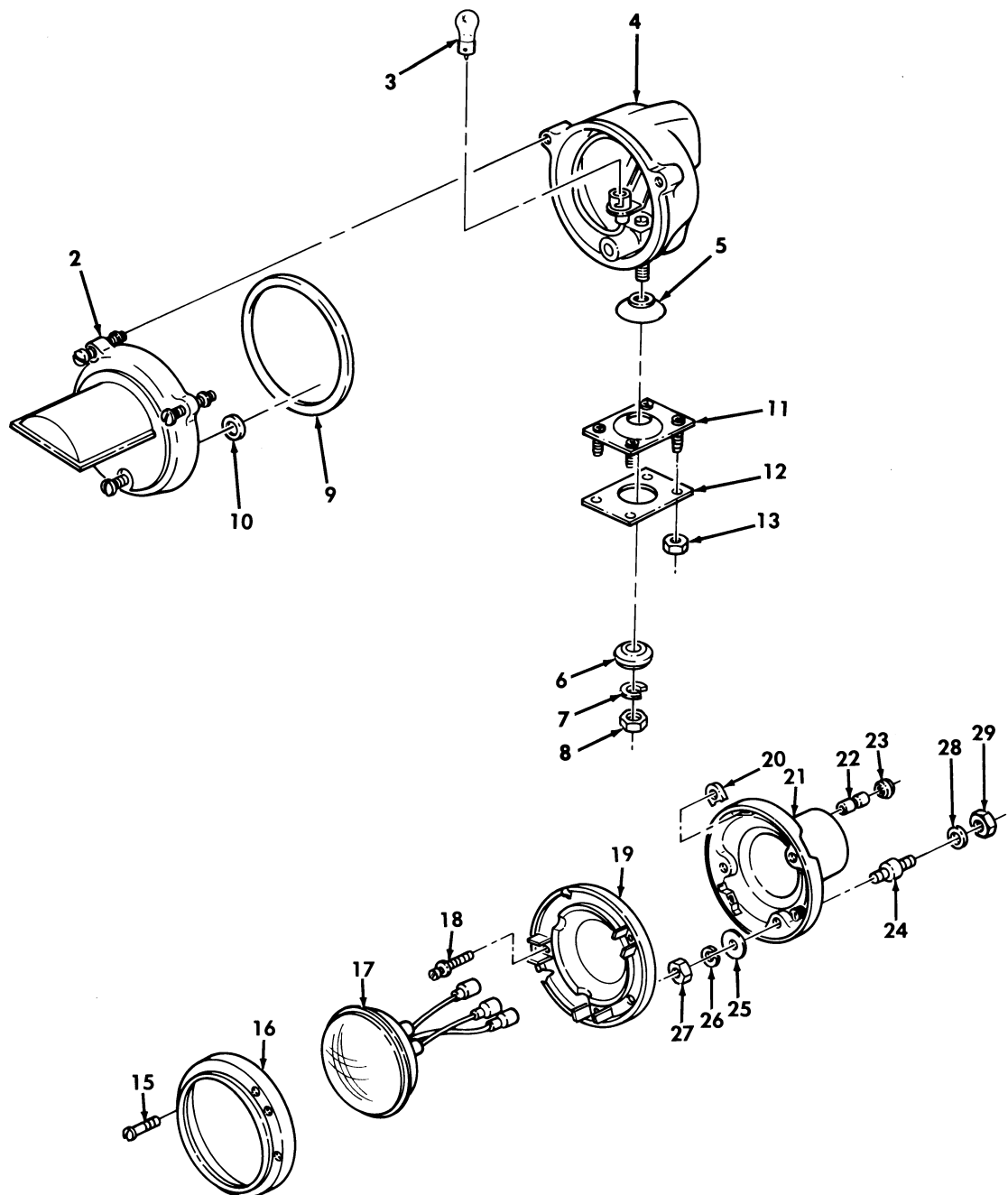
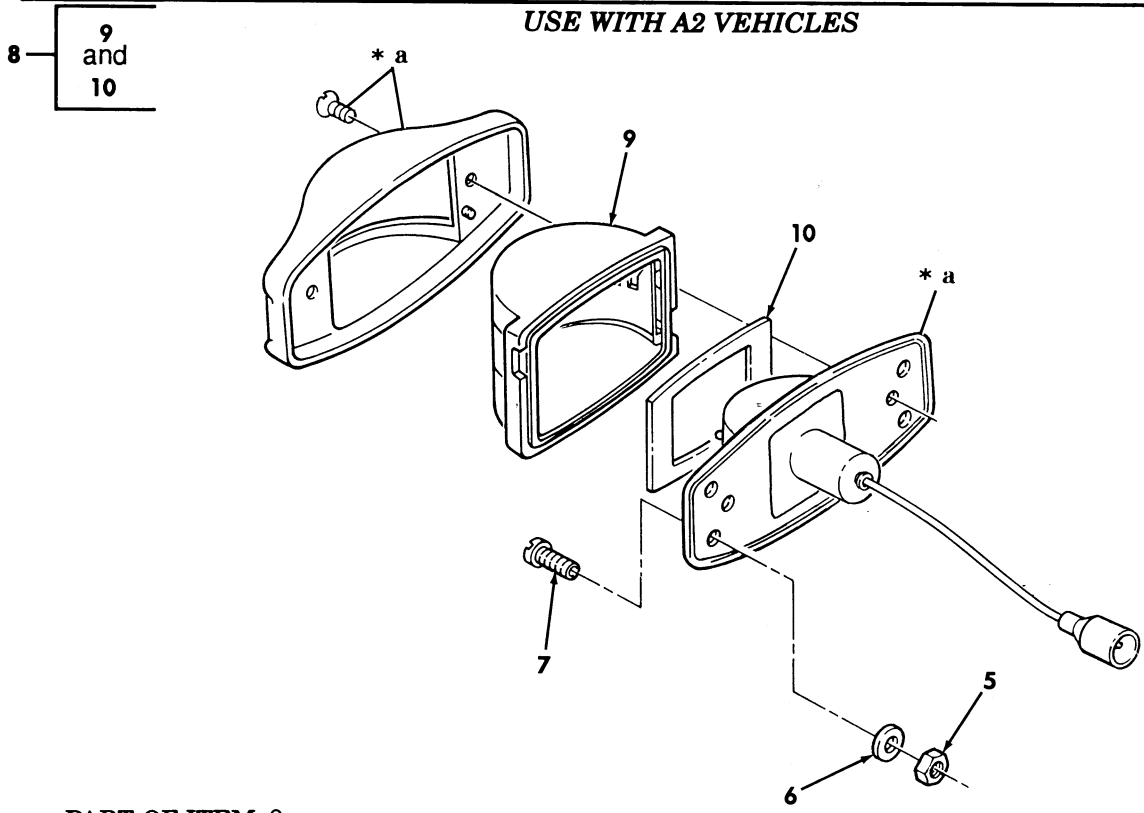
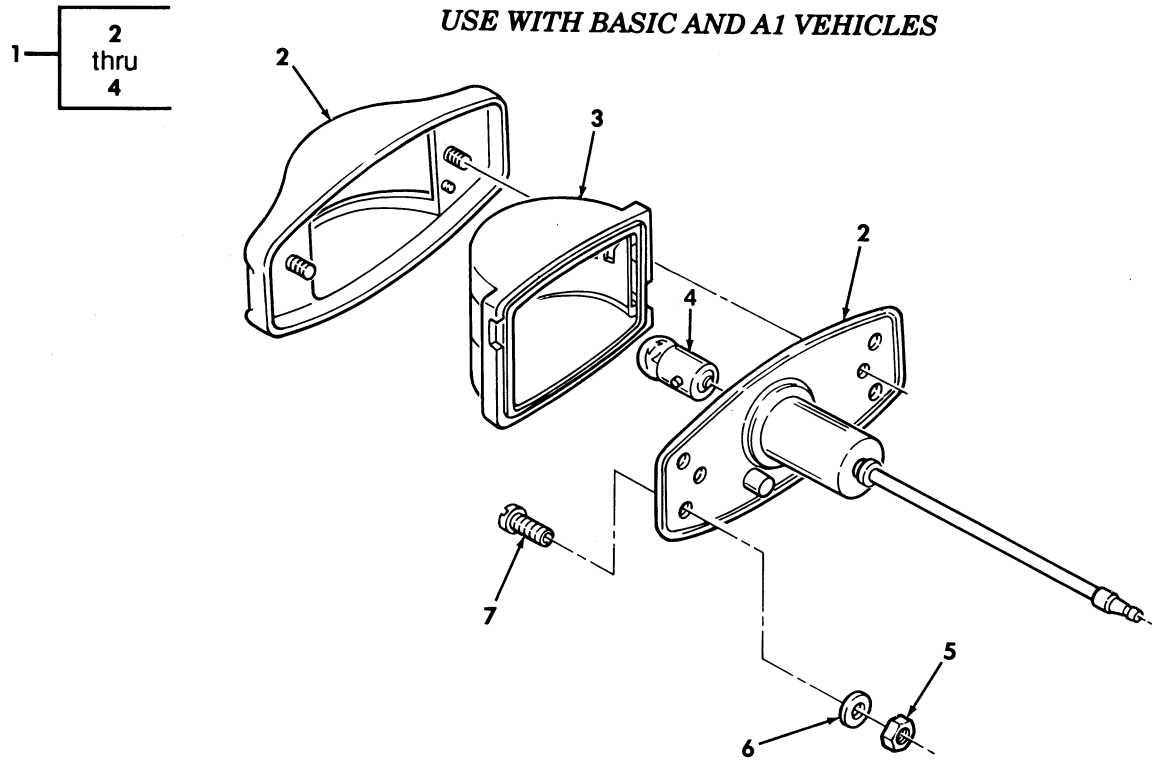

Figure 62. Blackout Lamp and Headlight Assembly.

SECTION II			TM9-2320-280-24P			
(1)	(2)	(3)	(4)	(5)	(6)	(7)
ITEM	SMR			PART		
NO	CODE	NSN	CAGEC	NUMBER	DESCRIPTION AND USABLE ON CODES(UOC)	QTY
GROUP 0609 LIGHTS						
FIG. 62 BLACKOUT LAMP AND HEADLIGHT ASSEMBLY						
1	PAOOO	6220010941440	19207	11668932	HEADLIGHT.....	1
2	PAOZZ	6220011072613	5A910	DC8218	.RETAINER,LENS 13/32.....	1
3	PAOZZ	6240000446914	58536	A52463-2-10	.LAMP,INCANDESCENT.....	1
4	PFOZZ	6220011280087	13873	DGSCV-91-157	.DOOR,BLACKOUT LAMP.....	1
5	PAOZZ	5310011002067	19207	11668979	.WASHER,LOCK 13/32.....	1
6	PAOZZ	5310003502655	56442	616G4	.WASHER,FINISHING.....	1
7	PAOZZ	5310006379541	96906	MS35338-46	.WASHER,LOCK 3/8.....	1
8	PAOZZ	5310007320558	96906	MS51967-8	.NUT,PLAIN,HEXAGON 3/8-16.....	1
9	PAOZZ	5330010370663	34623	MA128-21182	.GASKET.....	1
10	PAOZZ	5330010766172	34904	DC8226	.GASKET.....	3
11	PAOZZ	5340012866191	19207	12338605	COVER,ACCESS.....	1
12	PFOZZ	5365012115063	34623	5579941	SPACER,PLATE.....	1
13	PAOZZ	5310012510760	34623	G-00271166	NUT,PLAIN,ASSEMBLED #10-24.....	4
14	PAOOO	6220011931970	19207	12338611	HEADLIGHT.....	2
15	PAOZZ	5305008325743	19207	8741437	.SCREW,EXTERNALLY RE 1/4-20 X 1.125	3
16	PAOZZ	5325008325650	19207	8741446	.RING,RETAINING.....	1
17	PAOZZ	6240009663831	19207	8741491	.LAMP,INCANDESCENT.....	1
18	PAOZZ	5305003530969	19207	7538146	.SCREW,EXTERNALLY RE 1/4-28 X 1.00.	2
19	PFOZZ	6220009986142	19207	8741447	.RETAINER,LENS.....	1
20	PFOZZ	5310002416921	19207	8741435	.NUT BLANK.....	2
21	PFOZZ	6220004430589	19207	8741461	.HOUSING,LIGHT.....	1
22	PAOZZ	5935008074109	19207	8741492	.ADAPTER,CONNECTOR.....	3
23	PAOZZ	5325000886147	19207	8741442	.GROMMET,NONMETALLIC.....	3
24	PAOZZ	5340011972438	34623	5591169	.MOUNT,RESILIENT.....	3
25	PAOZZ	5310004630268	19207	5310615	.WASHER,FLAT 1/4.....	3
26	PAOZZ	5310005825965	96906	MS35338-44	.WASHER,LOCK 1/4.....	3
27	PAOZZ	5310007680319	96906	MS51968-2	.NUT,PLAIN,HEXAGON 1/4-28.....	3
28	PAOZZ	5310008094058	96906	MS27183-10	WASHER,FLAT 1/4.....	6
29	PAOZZ	5310013335245	24617	271175	NUT,SELF-LOCKING,HE 1/4-28.....	6

END OF FIGURE



\* a PART OF ITEM 8

Figure 63. Clearance Marker Light Assembly.

SECTION II			TM9-2320-280-24P			
(1)	(2)	(3)	(4)	(5)	(6)	(7)
ITEM NO	SMR CODE	NSN	CAGEC	PART NUMBER	DESCRIPTION AND USABLE ON CODES(UOC)	QTY
GROUP 0609 LIGHTS						
FIG. 63 CLEARANCE MARKER LIGHT ASSEMBLY						
1	PAOOO	6220005773434	96906	MS35423-1	LIGHT,MARKER,CLEARA FRONT..... UOC:AVY,A11,A13,A14,A15,A20,A24,A25, A26,A27,B16,B17,B18,HVY,H11,H13,H14, H15,H16,H17,H18,H20,H21,H24,H25,H26, H27,H28,MMM	2
1	PAOOO	6220007261916	96906	MS35423-2	LIGHT,MARKER,CLEARA REAR..... UOC:AVY,A11,A13,A14,A15,A20,A24,A25, A26,A27,B16,B17,B18,HVY,H11,H13,H14, H15,H16,H17,H18,H20,H21,H24,H25,H26, H27,H28,MMM	2
2	PFOZZ	6220007299295	96906	MS35422-1	.LIGHT,MARKER,CLEARA REAR AND FRONT UOC:AVY,A11,A13,A14,A15,A20,A24,A25, A26,A27,B16,B17,B18,HVY,H11,H13,H14, H15,H16,H17,H18,H20,H21,H24,H25,H26, H27,H28,MMM	1
3	PAOZZ	6220002997425	96906	MS35421-1	.LENS,LIGHT FRONT, AMBER..... UOC:AVY,A11,A13,A14,A15,A20,A24,A25, A26,A27,B16,B17,B18,HVY,H11,H13,H14, H15,H16,H17,H18,H20,H21,H24,H25,H26, H27,H28,MMM	1
3	PAOZZ	6220002997426	96906	MS35421-2	.LENS,LIGHT REAR,RED..... UOC:AVY,A11,A13,A14,A15,A20,A24,A25, A26,A27,B16,B17,B18,HVY,H11,H13,H14, H15,H16,H17,H18,H20,H21,H24,H25,H26, H27,H28,MMM	1
4	PAOZZ	6240000190877	08805	1251	.LAMP,INCANDESCENT REAR..... UOC:AVY,A11,A13,A14,A15,A20,A24,A25, A26,A27,B16,B17,B18,HVY,H11,H13,H14, H15,H16,H17,H18,H20,H21,H24,H25,H26, H27,H28,MMM	1
5	PAOZZ	5310009349764	96906	MS35649-205	NUT,PLAIN,HEXAGON REAR,#10-24.....	8
5	PAOZZ	5310012520481	34623	5593048	NUT,SELF-LOCKING,HE FRONT,#10-32...	8
6	PAOZZ	5310000145850	96906	MS27183-42	WASHER,FLAT REAR,#10.....	16
7	PAOZZ	5305009953444	96906	MS35207-266	SCREW,MACHINE REAR,#10-24 X 5/8....	8
7	PAOZZ	5305009846211	96906	MS35206-264	SCREW,MACHINE FRONT,#10-32 X 7/8...	8
8	PAOOO	6220014184404	19207	12446845-1	LIGHT,INDICATOR FRONT CLEARANCE.... UOC:BVY,B15,B20,B24,B25,C17,NNN	2
8	PAOOO	5980014439093	19207	12446845-2	LIGHT EMITTING DIOD REAR CLEARANCE. UOC:BVY,B15,B20,B24,B25,C17,NNN	2
9	PAOZZ	6220002997425	96906	MS35421-1	.LENS,LIGHT FRONT,AMBER..... UOC:BVY,B15,B20,B24,B25,C17,NNN	1
9	PAOZZ	6220002997426	96906	MS35421-2	.LENS,LIGHT REAR,RED..... UOC:BVY,B15,B20,B24,B25,C17,NNN	1
10	PAOZZ	5330003530959	73331	5939841	.FELT,MECHANICAL,PRE..... UOC:BVY,B15,B20,B24,B25,C17,NNN	1

END OF FIGURE

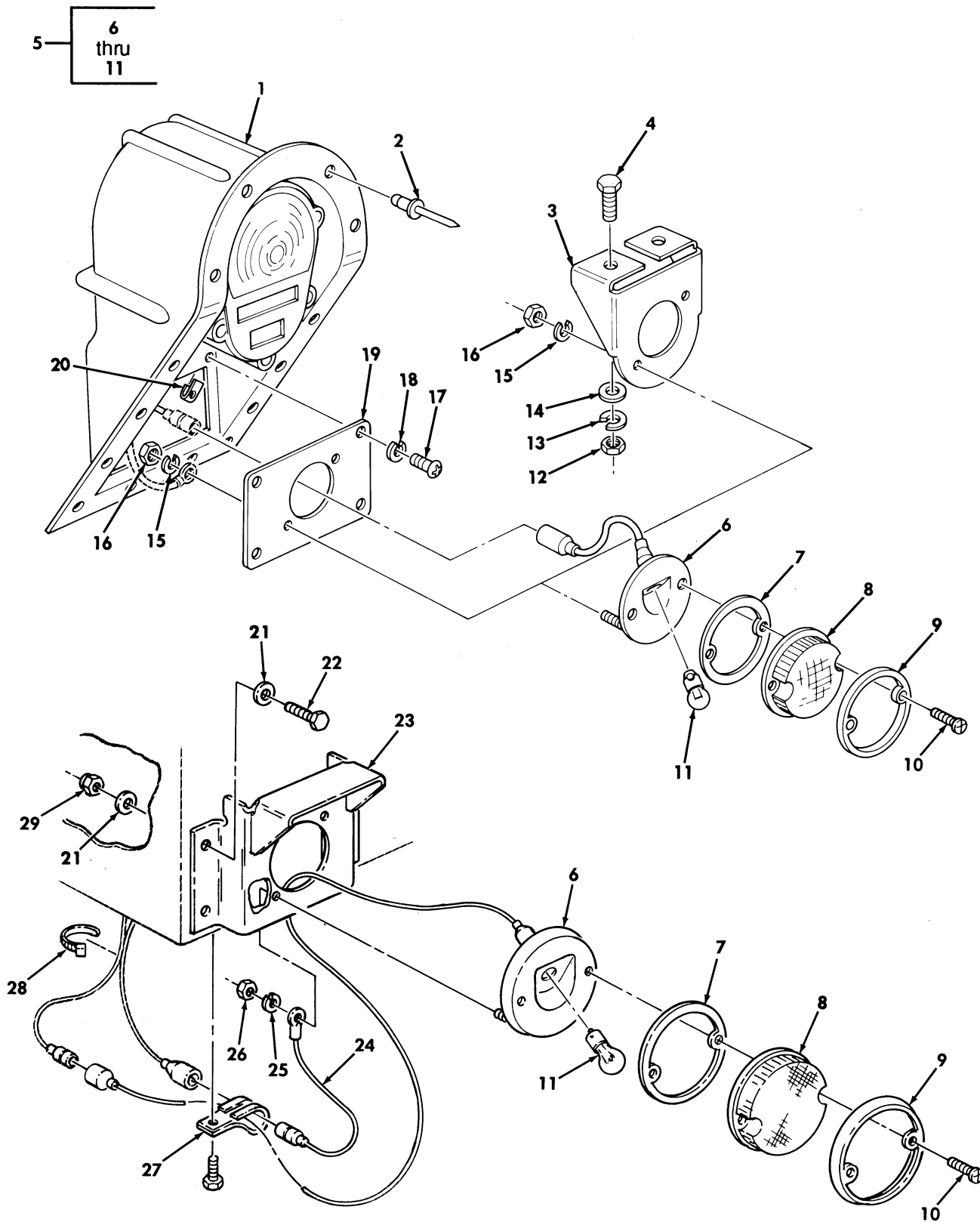

Figure 64. Backup Light Assembly and Mounting Hardware.

SECTION II			TM9-2320-280-24P			
(1)	(2)	(3)	(4)	(5)	(6)	(7)
ITEM	SMR			PART		
NO	CODE	NSN	CAGEC	NUMBER	DESCRIPTION AND USABLE ON CODES(UOC)	QTY
GROUP 0609 LIGHTS						
FIG. 64 BACKUP LIGHT ASSEMBLY AND MOUNTING HARDWARE						
1	PFOZZ	5340012974127	19207	12341575	BRACKET, MOUNTING.....	1
					UOC:A15, B15, B16, H15, H16	
2	PAOZZ	5320011361782	80205	NAS9301BNS-6-04	RIVET, BLIND 3/16.....	13
					UOC:A15, B15, H15	
2	PAOZZ	5320012751998	11815	BAPKTR-64	RIVET, BLIND 3/16 X .50-.250 GRIP...	13
					UOC:B16, H16	
3	PAOZZ	5340012197541	19207	12338676	BRACKET, ANGLE.....	2
					UOC:A20, H20	
4	PAOZZ	5306002072221	23862	2136455	BOLT, MACHINE.....	2
					UOC:A20, H20	
5	PAOOO	6220012165285	81834	01-6201-93	LIGHT, BACKUP.....	2
					UOC:A15, A20, B15, B16, B20, H15, H16, H20	
6	PFOZZ	6220012169337	81834	29-1063-02	.LIGHT, BACKUP.....	1
					UOC:A15, A20, B15, B16, B20, H15, H16, H20	
7	PAOZZ	5330012181196	81834	61-2028-01	.GASKET.....	1
					UOC:A15, A20, B15, B16, B20, H15, H16, H20	
8	PAOZZ	6220000011514	81834	90221	.LENS, LIGHT.....	1
					UOC:A15, A20, B15, B16, B20, H15, H16, H20	
9	PFOZZ	6695012168687	81834	10-7005-06	.BEZEL, INSTRUMENT MO.....	1
					UOC:A15, A20, B15, B16, B20, H15, H16, H20	
10	PAOZZ	5305012181243	81834	23-0118-27	.SCREW, MACHINE #10.....	2
					UOC:A15, A20, B15, B16, B20, H15, H16, H20	
11	PAOZZ	6240000446914	58536	A52463-2-10	.LAMP, INCANDESCENT 24 VOLTS.....	1
					UOC:A15, A20, B15, B16, B20, H15, H16, H20	
12	PAOZZ	5310007616882	96906	MS51967-2	NUT, PLAIN, HEXAGON 1/4-20.....	4
					UOC:A20, H20	
13	PAOZZ	5310006379541	96906	MS35338-46	WASHER, LOCK 1/4.....	4
					UOC:A20, H20	
14	PAOZZ	5310008094058	96906	MS27183-10	WASHER, FLAT 1/4.....	4
					UOC:A20, H20	
15	PAOZZ	5310009222017	72582	120217	WASHER, LOCK #10.....	4
					UOC:A15, A20, B15, B16, B20, H15, H16, H20	
16	PAOZZ	5310009349758	96906	MS35649-202	NUT, PLAIN, HEXAGON #10-24.....	4
					UOC:A15, A20, B15, B16, B20, H15, H16, H20	
17	PAOZZ	5305000546672	96906	MS51957-47	SCREW, MACHINE #8-32 X 3/4.....	4
					UOC:A15, B15, B16, H15, H16	
18	PAOZZ	5310000453299	96906	MS35338-42	WASHER, LOCK #8.....	4
					UOC:A15, B15, B16, H15, H16	
19	PAOZZ	6220012701454	19207	12341544	BACKING PLATE, LIGHT.....	1
					UOC:A15, B15, B16, H15, H16	
20	PAOZZ	5310012731635	78553	C-14329-8A04	NUT, SHEET SPRING #8-32.....	4
					UOC:A15, B15, B16, H15, H16	
21	PAOZZ	5310008094058	96906	MS27183-10	WASHER, FLAT.....	16
					UOC:B20	
22	PAOZZ	5305000680515	80204	B1821BH025F100N	SCREW, CAP, HEXAGON H.....	8
					UOC:B20	
23	PAOZZ		19207	12460455	BRACKET, MOUNTING.....	2
					UOC:B20	

SECTION II			TM9-2320-280-24P			
(1)	(2)	(3)	(4)	(5)	(6)	(7)
ITEM	SMR			PART		
NO	CODE	NSN	CAGEC	NUMBER	DESCRIPTION AND USABLE ON CODES(UC)	QTY
24	PAOZZ	2590012172662	19207	12339323	LEAD,WIRE,ELECTRICA.....	2
					UOC:B20	
25	PAOZZ	5310009222017	72582	120217	WASHER,LOCK.....	4
					UOC:B20	
26	PAOZZ	5310009349758	96906	MS35649-202	NUT,PLAIN,HEXAGON.....	4
					UOC:B20	
27	PAOZZ	5340008091494	96906	MS21333-105	CLAMP,LOOP.....	5
					UOC:B20	
28	PAOZZ	5975009846582	96906	MS3367-1-0	STRAP,TIEDOWN,ELECT.....	2
					UOC:B20	
29	PAOZZ	5310009359022	96906	MS51943-32	NUT,SELF-LOCKING,HE.....	8
					UOC:B20	

END OF FIGURE





SECTION II			TM9-2320-280-24P			
(1)	(2)	(3)	(4)	(5)	(6)	(7)
ITEM NO	SMR CODE	NSN	CAGEC	PART NUMBER	DESCRIPTION AND USABLE ON CODES(UOC)	QTY
GROUP 0609 LIGHTS						
FIG. 65 BLACKOUT,DOME,AND SPOTLIGHT M996,M996A1,M997,M997A1,AND M997A2 AMBULANCE						
1	PFOZZ	2590012767633	34623	5597243	MOLDING,METAL.....	2
					UOC:A15,B15,B16,H15,H16	
2	PAOZZ	5305012729042	34623	5593409	SCREW,CAP,HEXAGON H #10-32 X 3/4...	8
					UOC:A15,B15,B16,H15,H16	
3	PFOOO	6220012695263	0VDA9	922-621-02	LIGHT,MARKER,CLEARA.....	2
					UOC:A15,B15,B16,H15,H16	
4	PAOZZ	5935004626603	96906	MS27142-2	.CONNECTOR,PLUG,ELEC.....	1
					UOC:A15,B15,B16,H15,H16	
5	PAOZA	5935001677775	96906	MS27144-1	.CONNECTOR,PLUG,ELEC.....	1
					UOC:A15,B15,B16,H15,H16	
6	PAOZZ	9905010138723	81349	M43436/3-1	.BAND,MARKER.....	3
					UOC:A15,B15,B16,H15,H16	
7	PAOZZ	5325009286214	96906	MS35489-115	.GROMMET,NONMETALLIC.....	1
					UOC:A15,B15,B16,H15,H16	
8	PAOZZ	5305001647082	96906	MS51849-11	.SCREW,MACHINE #6-32 X 3/4.....	4
					UOC:A15,B15,B16,H15,H16	
9	PAOZZ	6220013382059	0VDA9	922-929-00	.LENS,LIGHT.....	1
					UOC:A15,B15,B16,H15,H16	
10	PAOZZ	6240000604707	62607	1309	.LAMP,INCANDESCENT 15 CANDLE POWER.	1
					UOC:A15,B15,B16,H15,H16	
11	PAOZZ	6250013396271	0VDA9	922-925-10	.BASE,LAMPHOLDER.....	1
					UOC:A15,B15,B16,H15,H16	
12	PAOOO	6220012697066	19207	12341239	LIGHT,DOME.....	4
					UOC:A15,B15,B16,H15,H16	
13	PAOZA	5935001152307	96906	MS27144-2	.CONNECTOR,PLUG,ELEC.....	1
					UOC:A15,B15,B16,H15,H16	
14	PAOZZ	9905010138723	81349	M43436/3-1	.BAND,MARKER.....	3
					UOC:A15,B15,B16,H15,H16	
15	PAOZZ	5305001647082	96906	MS51849-11	.SCREW,MACHINE #6-32 X 3/4.....	4
					UOC:A15,B15,B16,H15,H16	
16	PAOZZ	6240001557790	00303	308	.LAMP,INCANDESCENT.....	1
					UOC:A15,B15,B16,H15,H16	
17	PAOZZ	5935001152306	96906	MS27142-3	.CONNECTOR,PLUG,ELEC.....	1
					UOC:A15,B15,B16,H15,H16	
18	PAOZZ	5320010232529	81349	M24243/1-A404	RIVET,BLIND 1/8.....	8
					UOC:A15,B15,B16,H15,H16	
19	PAOZZ	5305000593660	96906	MS51958-64	SCREW,MACHINE #10-32 X 5/8.....	2
					UOC:A15,B15,B16,H15,H16	
20	PAOZZ	5340008437825	96906	MS21333-68	CLAMP,LOOP.....	2
					UOC:A15,B15,B16,H15,H16	
21	XBOZZ		34623	5593413	NUT #10-32.....	2
					UOC:A15,B15,B16,H15,H16	
22	PFOZZ	6230012698054	0VDA9	922-721-00	STAND,LIGHT.....	2
					UOC:A15,B15,B16,H15,H16	
23	PAOZZ	5305012725433	3M915	5593390	SCREW,MACHINE #10-32 X 1.00.....	4
					UOC:A15,B15,B16,H15,H16	
24	PAOOO	6220012661651	0VDA9	922-720-11	SPOTLIGHT.....	4

SECTION II			TM9-2320-280-24P			
(1)	(2)	(3)	(4)	(5)	(6)	(7)
ITEM	SMR			PART		
NO	CODE	NSN	CAGEC	NUMBER	DESCRIPTION AND USABLE ON CODES(UC)	QTY
24	PAOOO	6220012661651	0VDA9	922-720-11	UOC:A15,B15,H15 SPOTLIGHT.....	2
25	PAOZZ	6240000604707	08806	1309	UOC:B16,H16 .LAMP,INCANDESCENT 15 CANDLE POWER.	2
26	PAOZA	5935001677775	96906	MS27144-1	UOC:A15,B15,B16,H15,H16 .CONNECTOR,PLUG,ELEC.....	2
27	PAOZZ	5935004626603	96906	MS27142-2	UOC:A15,B15,B16,H15,H16 .CONNECTOR,PLUG,ELEC.....	2

END OF FIGURE

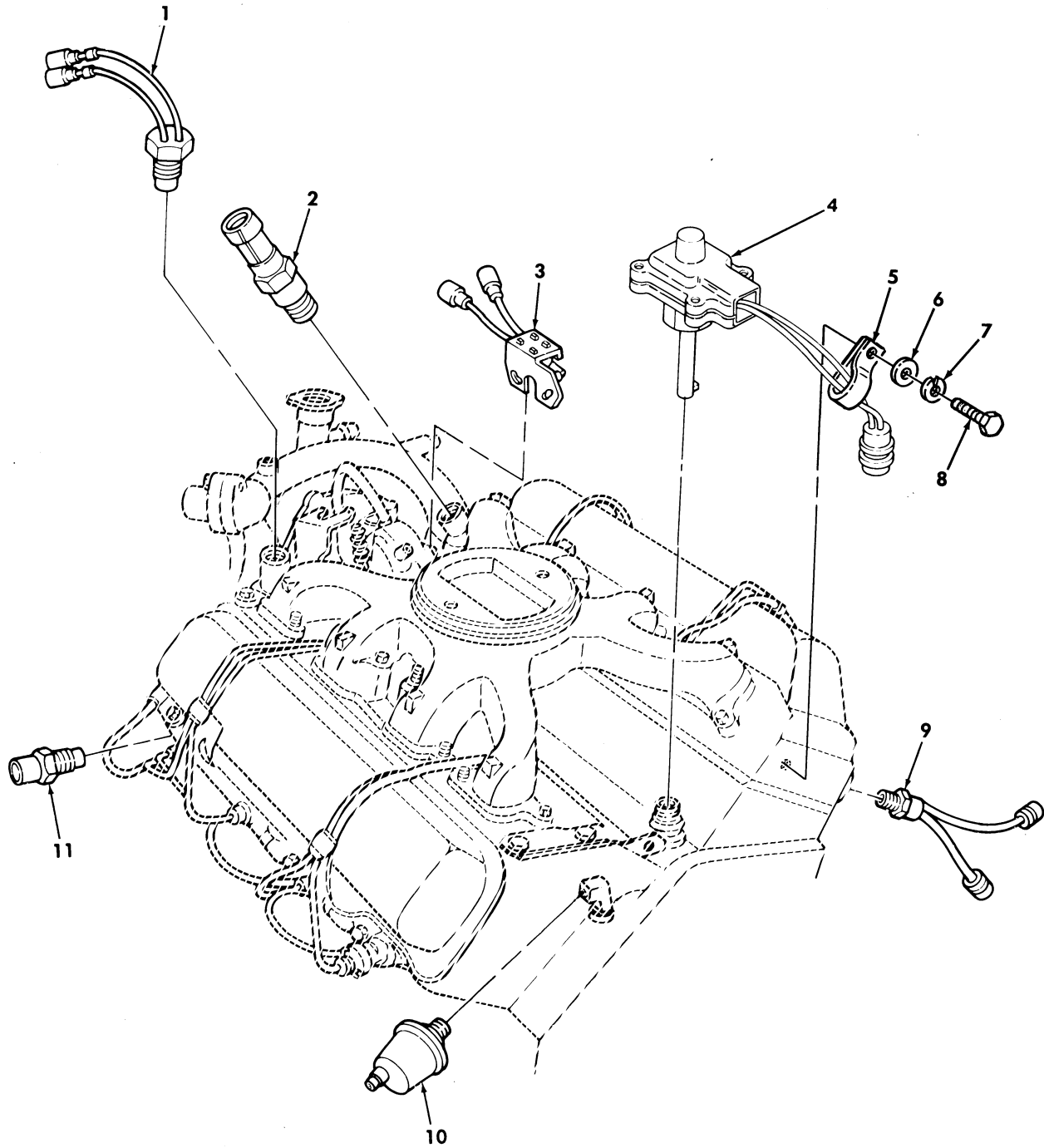

Figure 66. Sending Units.

SECTION II			TM9-2320-280-24P			
(1)	(2)	(3)	(4)	(5)	(6)	(7)
ITEM NO	SMR CODE	NSN	CAGEC	PART NUMBER	DESCRIPTION AND USABLE ON CODES(UOC)	QTY
GROUP 0610 SENDING UNITS AND WARNING SWITCHES						
FIG. 66 SENDING UNITS						
1	PAOZZ	5930012377322	19207	12338599	SWITCH, THERMOSTATIC.....	1
2	PAOZZ	2920011757214	19207	12338772	CONTROL UNIT, BREAK USE WITH NSN 6110013959585.....	1
2	PAOZZ	2920014696903	19207	12469158-2	COIL, ELECTRICAL USE WITH NSN 6110014701931.....	1
3	PAOZZ	5930011998853	19207	12339494	SWITCH, SENSITIVE..... UOC:AVY, A11, A13, A14, A15, A20, A24, A25, A26, A27, B16, B17, B18, HVY, H11, H13, H14, H15, H16, H17, H18, H20, H21, H24, H25, H26, H27, H28, MMM	1
4	PAOZZ	6680011488875	19207	12258931-2	TACHOMETER, MECHANIC.....	1
5	PAOZZ	5340008338476	96906	MS21333-122	CLAMP, LOOP..... UOC:BVY, B15, B20, B24, B25, C17, NNN	1
6	PAOZZ	5310000806004	96906	MS27183-14	WASHER, FLAT..... UOC:BVY, B15, B20, B24, B25, C17, NNN	1
7	PAOZZ	5310012067306	7X677	11500207	WASHER, LOCK..... UOC:BVY, B15, B20, B24, B25, C17, NNN	1
8	PAOZZ	5306012067172	7X677	11501940	BOLT, MACHINE..... UOC:BVY, B15, B20, B24, B25, C17, NNN	1
9	PAOZZ	5930011836637	19207	12338596	SWITCH, THERMOSTATIC.....	1
10	PAOZZ	6620009935546	19207	7416363	TRANSMITTER, PRESSUR.....	1
11	PAOZZ	6620011946586	09527	TS6058	TRANSMITTER, ENGINE.....	1

END OF FIGURE

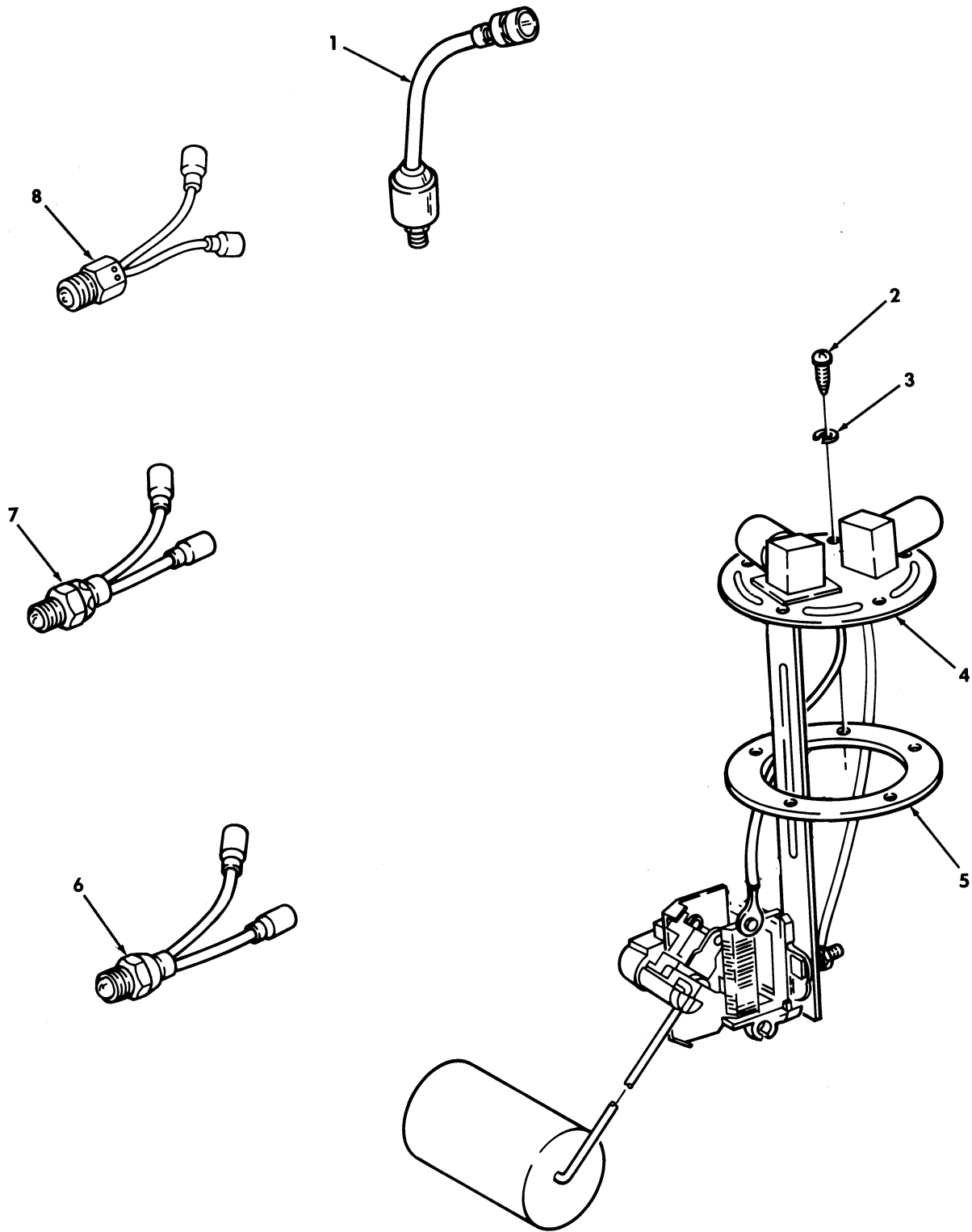

Figure 67. Fuel Pressure Transducer, Fuel Level Transmitter, Parking Brake, Backup Light Switches, and Transfer Indicator Switch.

SECTION II			TM9-2320-280-24P			
(1)	(2)	(3)	(4)	(5)	(6)	(7)
ITEM	SMR			PART		
NO	CODE	NSN	CAGEC	NUMBER	DESCRIPTION AND USABLE ON CODES(UC)	QTY
					GROUP 0610 SENDING UNIT AND WARNING SWITCHES	
					FIG. 67 FUEL PRESSURE TRANSDUCER, FUEL LEVEL TRANSMITTER, PARKING BRAKE, BACKUP LIGHT SWITCHES, AND TRANSFER INDICATOR SWITCH	
1	PAOZZ	6685011674298	34345	12258932-6	TRANSMITTER, PRESSUR.....	1
2	PAOZZ	5305002400194	96906	MS51849-76	SCREW, MACHINE #10-24 X 3/4.....	5
3	PAOZZ	5310009222017	72582	120217	WASHER, LOCK #10.....	5
4	PAOZZ	6680011851264	34623	5574995	TRANSMITTER, LIQUID.....	1
5	PAOZZ	5330007539072	19207	7539072	GASKET.....	1
6	PAOZZ	5930012123373	19207	12338435	SWITCH, SENSITIVE.....	1
7	PAOZZ	5930011836757	19207	12356704	SWITCH, PUSH.....	1
8	PAOZZ	6220013615084	34623	5938705	LIGHT, INDICATOR USE WITH TRANSFER ASSEMBLY P/N 5937387 OR P/N 12447125 UOC:AVY,A11,A13,A14,A15,A20,A24,A25,A26,A27,BVY,B15,B16,B17,B18,B20,B24,B25,C17,HVY,NNN	1

END OF FIGURE



SECTION II			TM9-2320-280-24P			
(1)	(2)	(3)	(4)	(5)	(6)	(7)
ITEM	SMR			PART		
NO	CODE	NSN	CAGEC	NUMBER	DESCRIPTION AND USABLE ON CODES(UOC)	QTY
GROUP 0611 HORN, SIREN						
FIG. 68 HORN AND HORN BUTTON ASSEMBLY						
1	PAOZZ	5305000680502	96906	MS90725-6	SCREW,CAP,HEXAGON H 1/4-20 X 3/4...	2
2	PFOZZ	5340011897558	19207	12338609	BRACKET,ANGLE.....	1
3	PAOZZ	5310006379541	96906	MS35338-46	WASHER,LOCK 1/4.....	2
4	PAOZZ	5310011480240	7X677	9419143	NUT,PLAIN,HEXAGON 1/4-20.....	2
5	PAOZZ	2590006830598	80252	9630	HORN,ELECTRICAL.....	1
6	PAOZZ	5305000680508	80204	B1821BH025F075N	.SCREW,CAP,HEXAGON H 1/4-28 X 3/4..	2
7	PAOZZ	5310005501130	96906	MS35333-40	.WASHER,LOCK 1/4.....	2
8	PAOZZ	5325011444871	19207	8754124	RING,RETAINING.....	1
9	PAOZZ	2530011890897	81263	7000	HORN BUTTON,VEHICLE.....	1
10	PAOZZ	5930011538215	19207	8754125	RETAINER,ELECTRICAL.....	1
11	PAOZZ	5977011939931	34623	5572983	CONTACT-TERMINAL,HO.....	1
12	PAOZZ	5305011977547	81263	46827	SCREW,ASSEMBLED WAS.....	2

END OF FIGURE



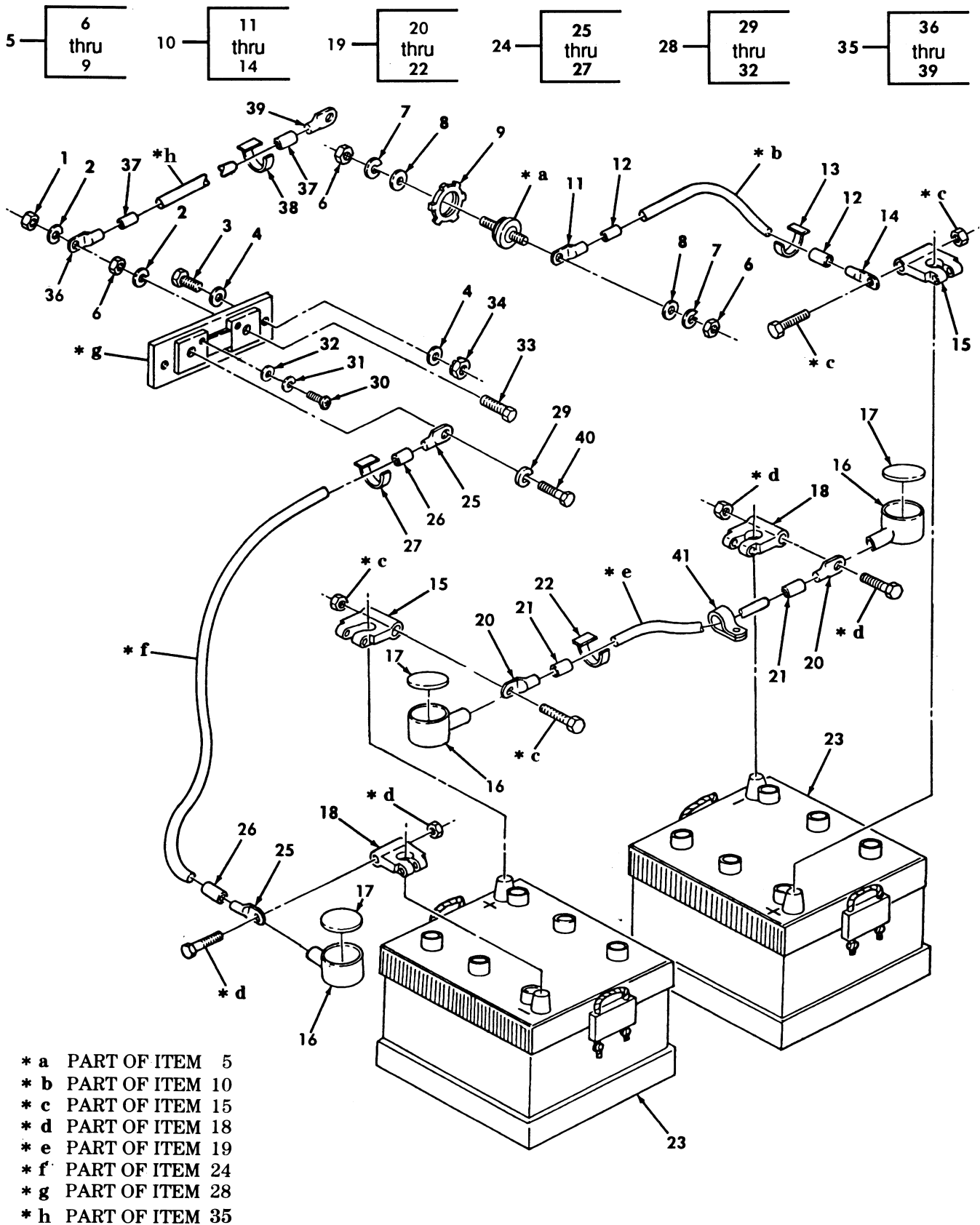

Figure 69. Batteries, Cables, and Related Parts.

SECTION II			TM9-2320-280-24P			
(1)	(2)	(3)	(4)	(5)	(6)	(7)
ITEM NO	SMR CODE	NSN	CAGEC	PART NUMBER	DESCRIPTION AND USABLE ON CODES(UOC)	QTY
GROUP 0612 BATTERIES,STORAGE						
FIG. 69 BATTERIES,CABLES,AND RELATED PARTS						
1	PAOZZ	5310007680318	24617	9413509	NUT,PLAIN,HEXAGON 1/2-13.....	2
2	PAOZZ	5310005845272	02978	ERNA245	WASHER,LOCK 1/2.....	2
3	PAOZZ	5305011951575	7X677	9437889	SCREW,MACHINE 1/4-20 X 1.00.....	2
5	PFOZZ	5940011803655	13445	46211-03	TERMINAL,FEEDTHRU.....	1
6	PAOZZ	5310011857188	13445	85764	.NUT,PLAIN,HEXAGON.....	2
7	PAOZZ	5310011867066	13445	85031	.WASHER,LOCK 1/2.....	2
8	PAOZZ	5310011857208	13445	88587	.WASHER,FLAT 1/2.....	2
UOC:AVY,BVY						
9	PAOZZ	5310011866930	13445	83320	.NUT.....	1
10	MOOOO		34623	5578875	CABLE ASSEMBLY MAKE FROM WIRE,P/N M13486/1-14, 25 INCHES LONG.....	1
11	PAOZZ	5940007355520	56501	TG33	.TERMINAL,LUG.....	1
12	PAOZZ	5970002215301	71124	TURBOLEX76B	.INSULATION SLEEVING.....	2
13	PAOZZ	9905008933570	81349	M43436/1-3	.BAND,MARKER.....	1
14	PAOZZ	5940001155006	96906	MS25036-133	.TERMINAL,LUG.....	1
15	PAOZZ	5940005496581	58536	A52425-1	ADAPTER,BATTERY TER.....	2
16	PAOZZ	5340013785201	19207	12342646	BOOT,DUST AND MOIST PART OF KIT P/N 5935425.....	3
17	PAOZZ	5340013787525	19207	12342647	CAP,PROTECTIVE,DUST PART OF KIT P/N 5935425.....	3
18	PAOZZ	5940005496583	19207	7320533	ADAPTER,BATTERY TER.....	2
19	MOOOO		34623	5578876	CABLE ASSEMBLY MAKE FROM WIRE, P/N M13486/1-14, 13 INCHES LONG.....	1
20	PAOZZ	5940001155006	96906	MS25036-133	.TERMINAL,LUG.....	2
21	PAOZZ	5970002215301	14429	RESINITEEP69C	.INSULATION SLEEVING.....	2
22	PAOZZ	9905008933570	81349	M43436/1-3	.BAND,MARKER.....	1
23	PAOFA	6140014469498	19207	6TLMFTYI	BATTERY,STORAGE.....	2
24	MOOOO		34623	5578874	CABLE ASSEMBLY MAKE FROM WIRE, P/N M13486/1-14, 21 INCHES LONG.....	1
25	PAOZZ	5940001155006	96906	MS25036-133	.TERMINAL,LUG.....	2
26	PAOZZ	5970002215301	14429	RESINITEEP69C	.INSULATION SLEEVING.....	2
27	PAOZZ	9905008933570	81349	M43436/1-3	.BAND,MARKER.....	1
28	PAOZZ	6625011927498	19207	12340570	SHUNT,INSTRUMENT.....	1
29	PAOZZ	5310001848971	96906	MS35338-103	.WASHER,LOCK 3/8.....	1
30	PAOZZ	5305002062508	80205	MS35215-53	.SCREW,MACHINE #10-32 X .375.....	2
31	PAOZZ	5310002618278	96906	MS35338-100	.WASHER,LOCK #10.....	2
32	PAOZZ	5310000455207	96906	MS15795-908	.WASHER,FLAT #10.....	2
33	PAOZZ	5305013158649	19207	12342338	SCREW,CAP,HEXAGON H 1/2 X 3.00.....	1
34	PAOZZ	5310011520598	24617	271172	NUT,SELF-LOCKING,AS 1/4-20.....	2
35	PAOZZ	6150014173411	19207	12446821-3	LEAD,ELECTRICAL.....	1
UOC:BVY,B15,B20,B24,B25,C17,NNN						
36	PAOZZ	5940007355520	19207	7355520	.TERMINAL,LUG.....	1
UOC:BVY,B15,B20,B24,B25,C17,NNN						
37	MOOZZ		81349	M23053/4-304-0-1	.INSULATION SLEEVING MAKE FROM INSULATION SLEEVING,P/N M23053/4-304-0,1 INCH LONG.....	2
UOC:BVY,B15,B20,B24,B25,C17,NNN						
38	PAOZZ	9905008933570	81349	M43436/1-3	.BAND,MARKER.....	2

SECTION II			TM9-2320-280-24P			
(1)	(2)	(3)	(4)	(5)	(6)	(7)
ITEM	SMR			PART		
NO	CODE	NSN	CAGEC	NUMBER	DESCRIPTION AND USABLE ON CODES(UC)	QTY
39	PAOZZ	5940001152685	96906	MS20659-152	UC:BVY,B15,B20,B24,B25,C17,NNN . TERMINAL,LUG.....	1
40	PAOZZ	5306004258569	24617	174697	UC:BVY,B15,B20,B24,B25,C17,NNN BOLT,MACHINE 3/8-16.....	1
41	PAOZZ	5340000573052	96906	MS21333-114	CLAMP,LOOP.....	1

END OF FIGURE

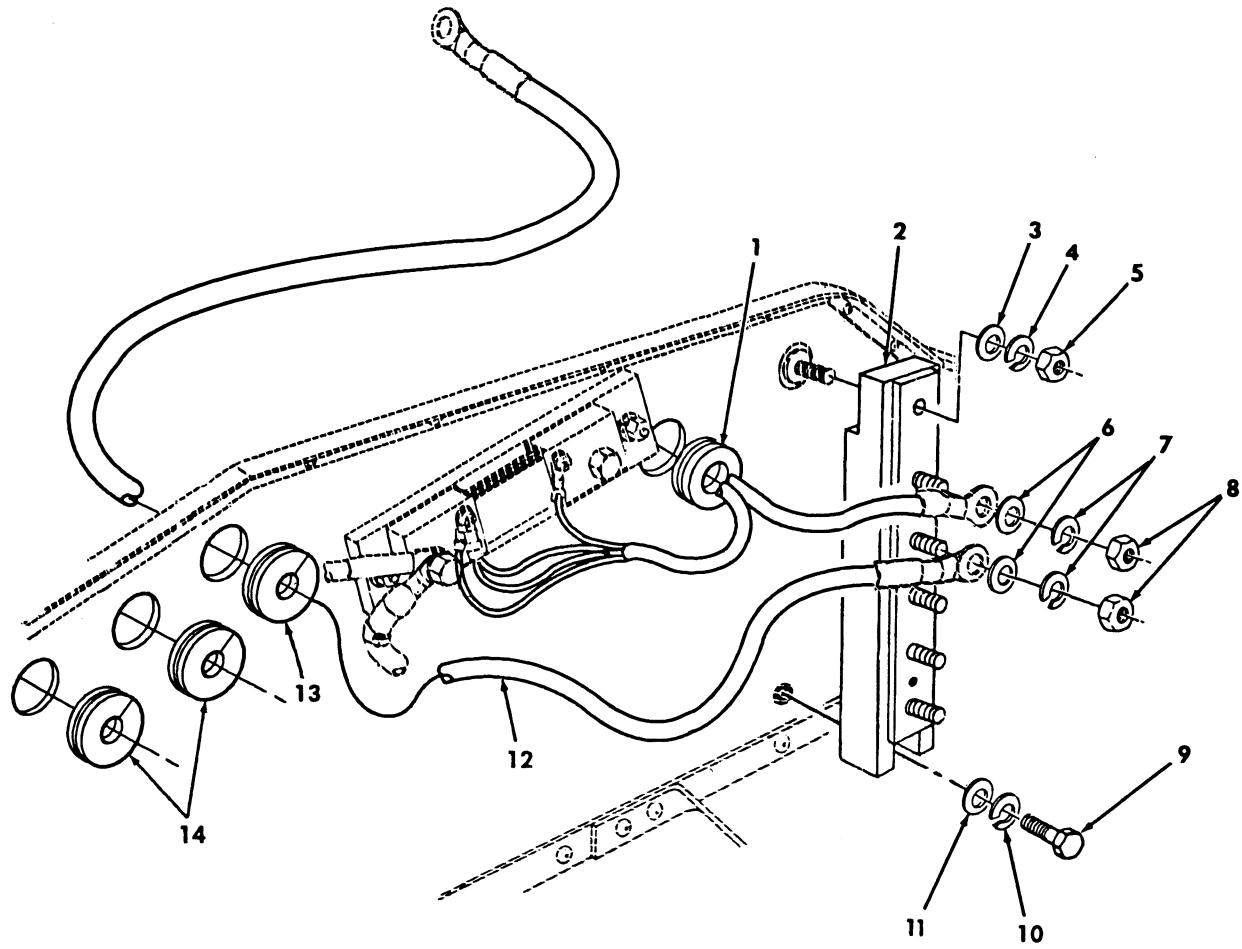

Figure 70. Buss Bar and Related Parts.

SECTION II			TM9-2320-280-24P			
(1)	(2)	(3)	(4)	(5)	(6)	(7)
ITEM	SMR			PART		
NO	CODE	NSN	CAGEC	NUMBER	DESCRIPTION AND USABLE ON CODES(UOC)	QTY
GROUP 0612 BATTERIES, STORAGE						
FIG. 70 BUSS BAR AND RELATED PARTS						
1	PAOZZ	5325001749038	76385	S1608	GROMMET, NONMETALLIC.....	1
					UOC: BVY, B15, B20, B24, B25, C17, NNN	
2	PAOZZ	6150014137946	19207	12460070	BUS, CONDUCTOR.....	1
					UOC: BVY, B15, B20, B24, B25, C17, NNN	
3	PAOZZ	5310011857208	13445	88587	WASHER, FLAT.....	2
					UOC: BVY, B15, B20, B24, B25, C17, NNN	
4	PAOZZ	5310011867066	13445	85031	WASHER, LOCK.....	2
					UOC: BVY, B15, B20, B24, B25, C17, NNN	
5	PAOZZ	5310011857188	13445	85764	NUT, PLAIN, HEXAGON.....	2
					UOC: BVY, B15, B20, B24, B25, C17, NNN	
6	PAOZZ	5310000455218	96906	MS15795-918	WASHER, FLAT 1/2.....	5
					UOC: BVY, B15, B20, B24, B25, C17, NNN	
7	PAOZZ	5310000116121	96906	MS35338-67	WASHER, LOCK 1/2.....	5
					UOC: BVY, B15, B20, B24, B25, C17, NNN	
8	PAOZZ	5310009135474	96906	MS51969-5	NUT, PLAIN, HEXAGON 1/2-13.....	5
					UOC: BVY, B15, B20, B24, B25, C17, NNN	
9	PAOZZ	5305000680502	96906	MS90725-6	SCREW, CAP, HEXAGON H.....	1
					UOC: BVY, B15, B20, B24, B25, C17, NNN	
10	PAOZZ	5310006379541	96906	MS35338-46	WASHER, LOCK 1/4.....	1
					UOC: BVY, B15, B20, B24, B25, C17, NNN	
11	PAOZZ	5310008094058	96906	MS27183-10	WASHER, FLAT 1/4.....	4
					UOC: BVY, B15, B20, B24, B25, C17, NNN	
12	PAOZZ	6150014167899	19207	12446825	LEAD, ELECTRICAL CABLE ASSEMBLY	1
					POSITIVE, 200AMP.....	
					UOC: BVY, B15, NNN	
13	PAOZZ	5325002901960	96906	MS35489-27	GROMMET, NONMETALLIC.....	1
					UOC: BVY, B15, NNN	
14	PAOZZ	5325002766343	96906	MS35489-23	GROMMET, NONMETALLIC.....	2
					UOC: BVY, B15, B20, B24, B25, C17, NNN	

END OF FIGURE

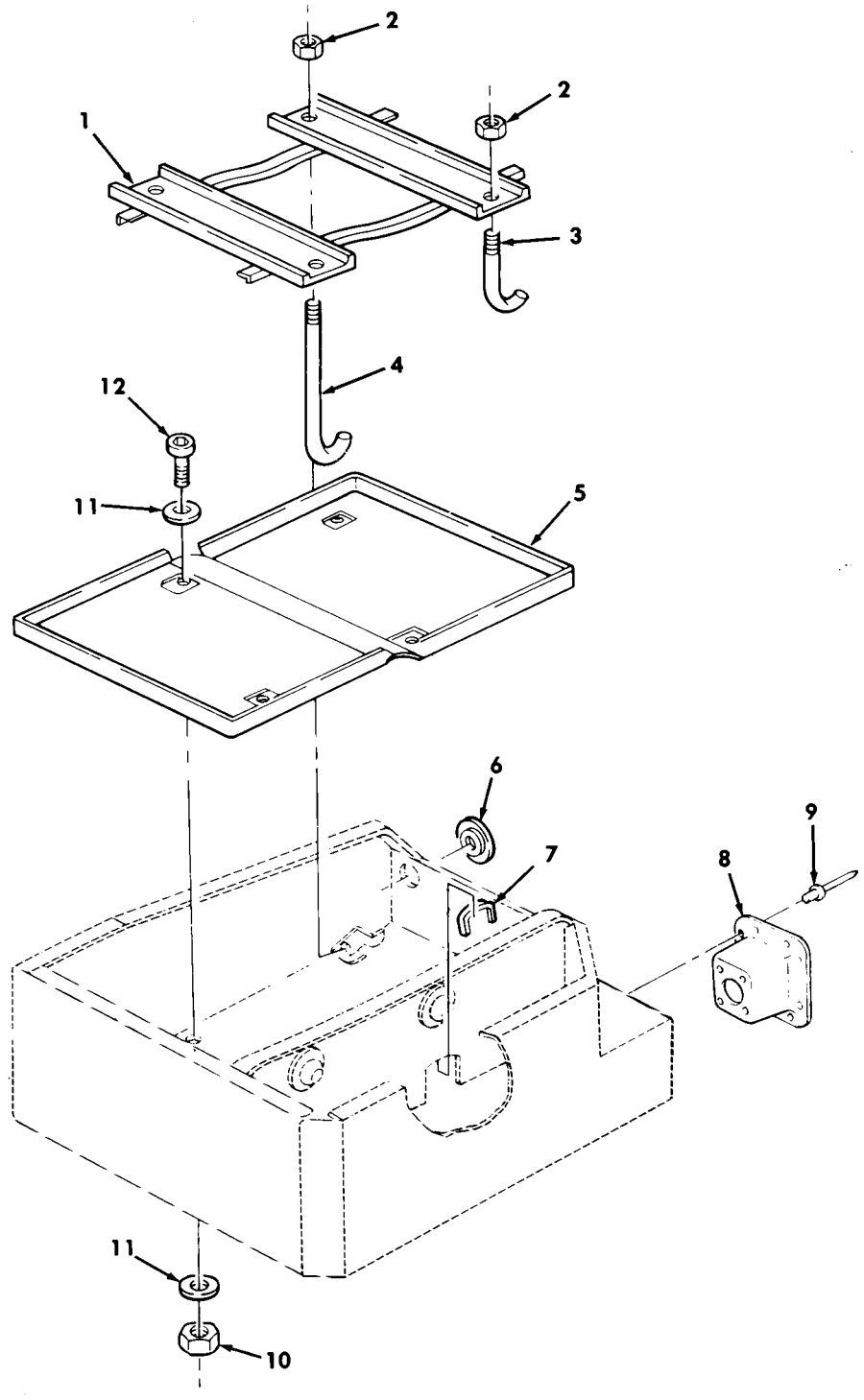

Figure 71. Battery Mounting Components and Related Parts.

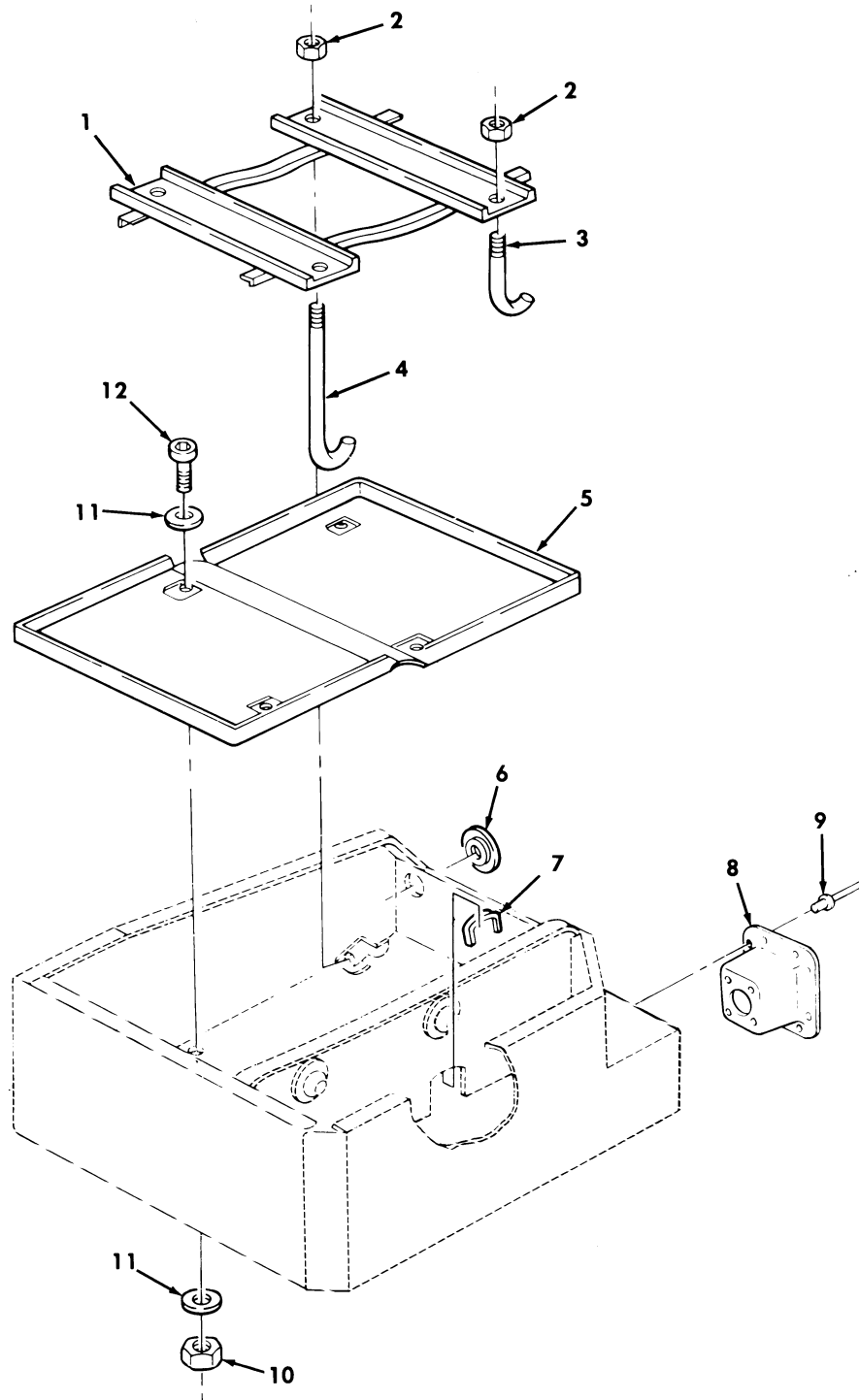

Figure 71. Battery Mounting Components and Related Parts.

SECTION II			TM9-2320-280-24P			
(1)	(2)	(3)	(4)	(5)	(6)	(7)
ITEM NO	SMR CODE	NSN	CAGEC	PART NUMBER	DESCRIPTION AND USABLE ON CODES(UOC)	QTY
GROUP 0612 BATTERIES,STORAGE						
FIG. 71 BATTERY MOUNTING COMPONENTS AND RELATED PARTS						
1	PFOZZ	6160011840643	19207	12339034	RETAINER,BATTERY.....	1
2	PAOZZ	5310008807744	96906	MS51967-5	NUT,PLAIN,HEXAGON 5/16-18.....	4
3	PAOZZ	5306011857071	34623	5596271	BOLT,HOOK.....	2
4	PAOZZ	5306011902193	19207	12339013	BOLT,HOOK.....	2
5	PFOZZ	6160011840728	19207	12339035	TRAY,BATTERY.....	1
6	PAOZZ	5325011958002	70485	963	GROMMET,NONMETALLIC.....	1
7	MOOZZ		34623	SF5575898	EDGE PROTECTOR MAKE FROM GROMMET,P/ N MS21266-2N,4.5 INCHES LONG.....	1
8	PAOZZ	5342012824853	19207	12339017	MOUNT,RESILIENT.....	1
9	PAOZZ	5320012716357	9K475	MGLP-B6-4	RIVET,BLIND 3/16 X .270 GRIP.....	8
10	PAOZZ	5310000614650	96906	MS51943-31	NUT,SELF-LOCKING,HE 1/4-20.....	4
11	PAOZZ	5310008093078	96906	MS27183-11	WASHER,FLAT 1/4.....	8
12	PAOZZ	5305010165469	72582	186676	SCREW,CAP,HEXAGON H 1/4-20 X 5/8...	4

END OF FIGURE



Section II.

TM 9-2320-280-24P-1

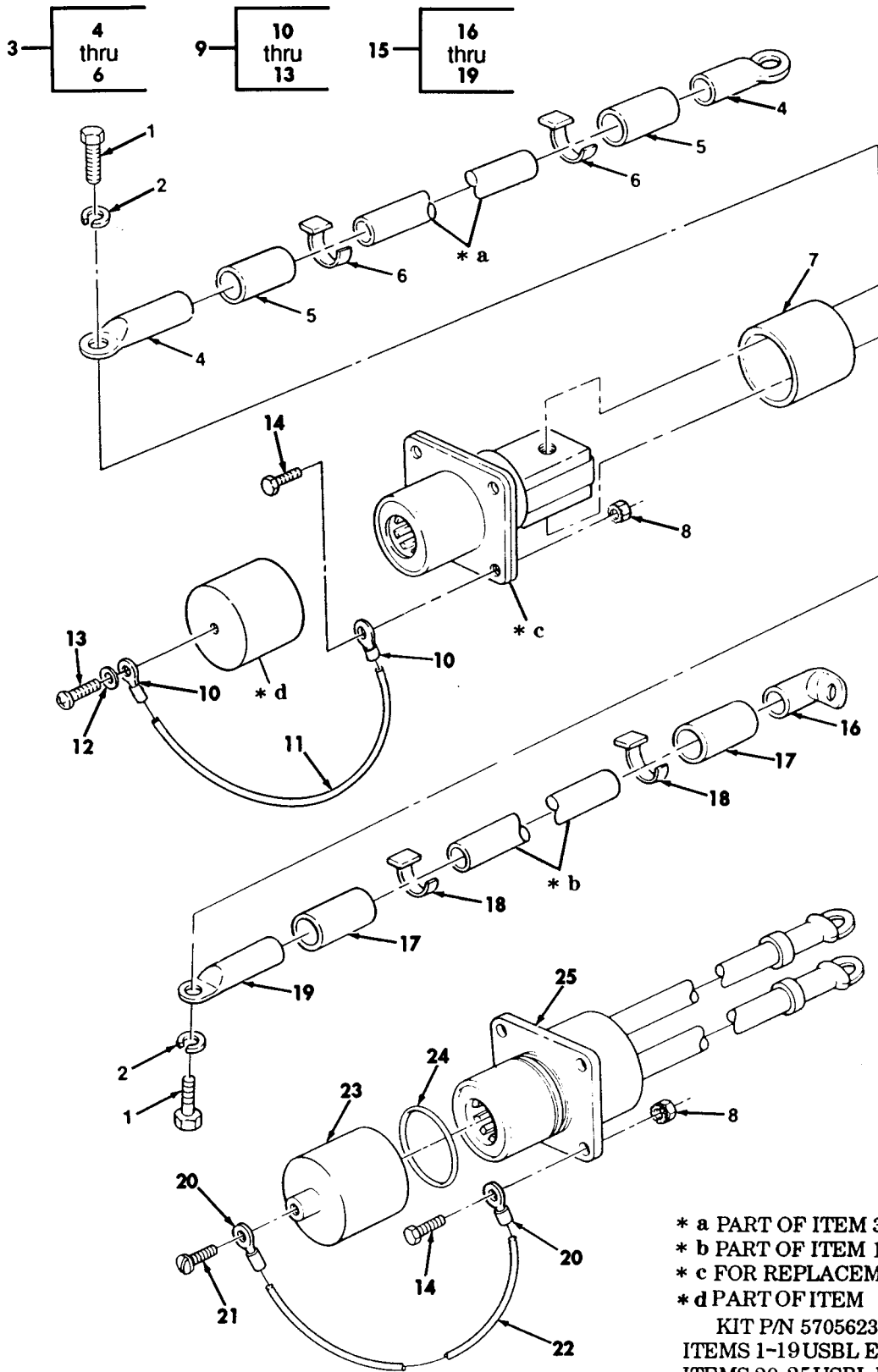

\* a PART OF ITEM 3  
 \* b PART OF ITEM 15  
 \* c FOR REPLACEMENT USE P/N 12342917  
 \* d PART OF ITEM 9  
 KIT P/N 5705623 OR 5705624  
 ITEMS 1-19 USBL EFF 1 THRU 99,999  
 ITEMS 20-25 USBL EFF 100,000 AND ABOVE

Figure 72. Slave Receptacle and Cable Assemblies.

Section II.

TM 9-2320-280-24P-1

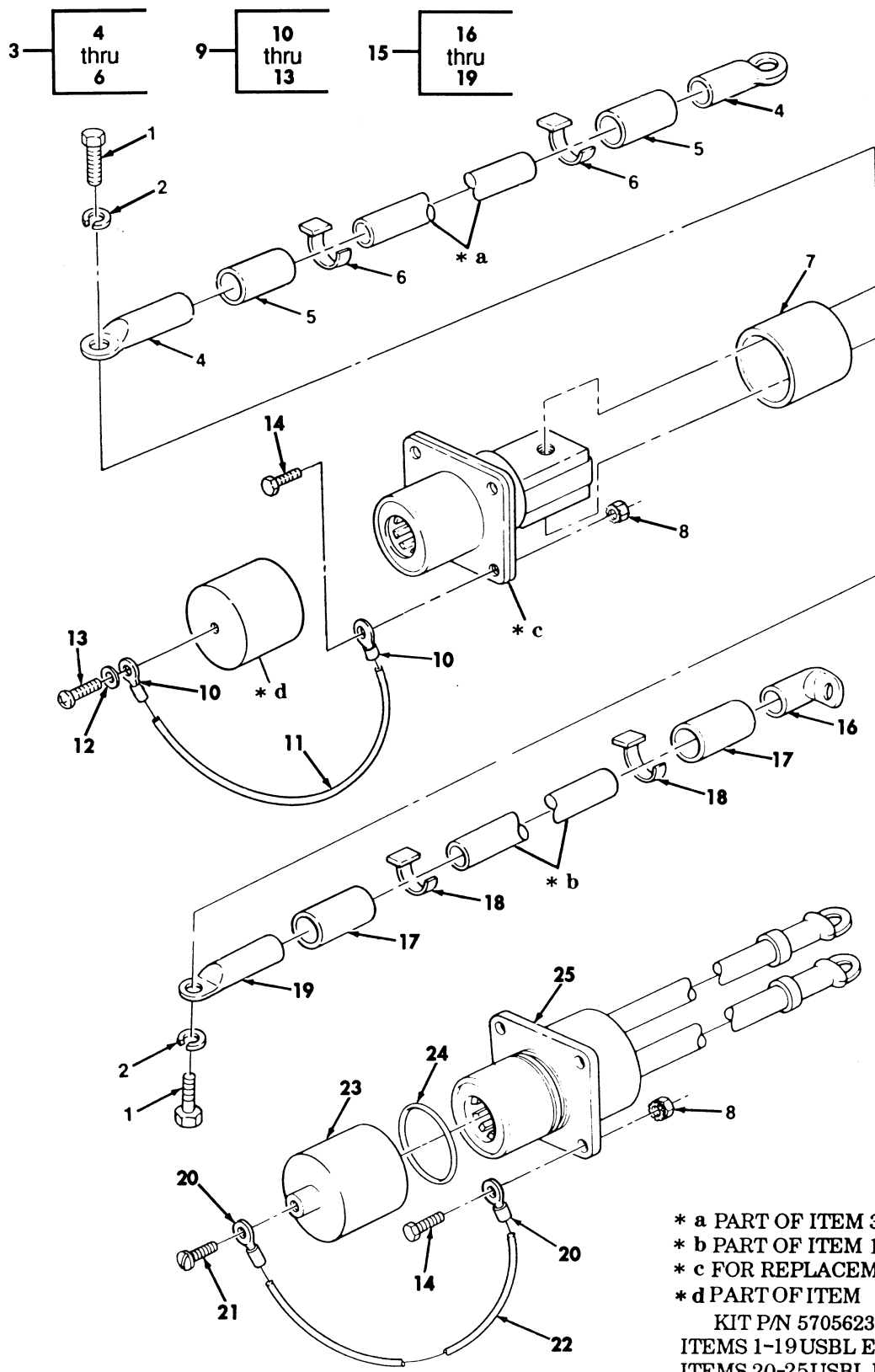

Figure 72. Slave Receptacle and Cable Assemblies.

SECTION II			TM9-2320-280-24P			
(1)	(2)	(3)	(4)	(5)	(6)	(7)
ITEM NO	SMR CODE	NSN	CAGEC	PART NUMBER	DESCRIPTION AND USABLE ON CODES(UOC)	QTY
GROUP 0612 BATTERIES,STORAGE						
FIG.72 SLAVE RECEPTACLE AND CABLE ASSEMBLIES						
1	PAOZZ	5305001159526	96906	MS90725-58	SCREW,CAP,HEXAGON H 3/8-24 X 3/4, USBL EFF 1 THRU 99,999..... UOC:H11,H13,H14,H15,H16,H17,H18,H20, H21,H24,H25,H26,H27,H28,MMM	2
2	PAOZZ	5310006379541	96906	MS35338-46	WASHER,LOCK..... UOC:H11,H13,H14,H15,H16,H17,H18,H20, H21,H24,H25,H26,H27,H28,MMM	2
3	MOOOO		34623	5578878	CABLE ASSEMBLY MAKE FROM WIRE,P/N M13486/1-14,36 INCHES LONG,USBL EFF 1 THRU 99,999..... UOC:H11,H13,H14,H15,H16,H17,H18,H20, H21,H24,H25,H26,H27,H28,MMM	1
4	PAOZZ	5940001155006	96906	MS25036-133	.TERMINAL,LUG USBL EFF 1 THRU 99, 999..... UOC:H11,H13,H14,H15,H16,H17,H18,H20, H21,H24,H25,H26,H27,H28,MMM	2
5	PAOZZ	5970002215301	14429	RESINITEEP69C	.INSULATION SLEEVING USBL EFF 1 THRU 99,999..... UOC:H11,H13,H14,H15,H16,H17,H18,H20, H21,H24,H25,H26,H27,H28,MMM	2
6	PAOZZ	9905008933570	81349	M43436/1-3	.BAND,MARKER USBL EFF 1 THRU 99,999 UOC:H11,H13,H14,H15,H16,H17,H18,H20, H21,H24,H25,H26,H27,H28,MMM	2
7	PAOZZ	5365012067486	19207	12339337	SPACER,SLEEVE USBL EFF 1 THRU 99, 999..... UOC:H11,H13,H14,H15,H16,H17,H18,H20, H21,H24,H25,H26,H27,H28,MMM	1
8	PAOZZ	5310009954130	78189	511-120800-00	NUT,PLAIN,ASSEMBLED 12-24,USBL EFF 1 THRU 99,999..... UOC:H11,H13,H14,H15,H16,H17,H18,H20, H21,H24,H25,H26,H27,H28,MMM	4
9	PAOZZ	5340010590114	19207	11675004	CAP,PROTECTIVE,DUST USBL EFF 1 THRU 99,999..... UOC:H11,H13,H14,H15,H16,H17,H18,H20, H21,H24,H25,H26,H27,H28,MMM	1
10	PAOZZ	5940001434794	98410	C-828-10	.TERMINAL,LUG USBL EFF 1 THRU 99, 999..... UOC:H11,H13,H14,H15,H16,H17,H18,H20, H21,H24,H25,H26,H27,H28,MMM	2
11	MOOZZ		81755	P5006-4G-9	CORD,FIBROUS SLAVE MAKE FROM CORD, P/N P5006-4G,9 INCHES LONG,USBL EFF 1 THRU 99,999..... UOC:H11,H13,H14,H15,H16,H17,H18,H20, H21,H24,H25,H26,H27,H28,MMM	1
12	PAOZZ	5310005795554	96906	MS35333-35	.WASHER,LOCK USBL EFF 1 THRU 99,999 UOC:H11,H13,H14,H15,H16,H17,H18,H20, H21,H24,H25,H26,H27,H28,MMM	1
13	PAOZZ	5305009584357	96906	MS35207-242	.SCREW,MACHINE USBL EFF 1 THRU 99,	1

SECTION II			TM9-2320-280-24P			
(1)	(2)	(3)	(4)	(5)	(6)	(7)
ITEM NO	SMR CODE	NSN	CAGEC	PART NUMBER	DESCRIPTION AND USABLE ON CODES(UOC)	QTY
					999..... UOC:H11,H13,H14,H15,H16,H17,H18,H20, H21,H24,H25,H26,H27,H28,MMM	
14	PAOZZ	5305008412044	16764	9418913	SCREW,MACHINE 12-24 X 7/8.....	4
					UOC:H11,H13,H14,H15,H16,H17,H18,H20, H21,H24,H25,H26,H27,H28,MMM	
15	MOOOO		34623	5578877	CABLE ASSEMBLY MAKE FROM WIRE,P/N M13486/1-14,36 INCHES LONG,USEL EFF 1 THRU 99,999.....	1
					UOC:H11,H13,H14,H15,H16,H17,H18,H20, H21,H24,H25,H26,H27,H28,MMM	
16	PAOZZ	5940007355520	56501	TG33	.TERMINAL,LUG USBL EFF 1 THRU 99, 999.....	1
					UOC:H11,H13,H14,H15,H16,H17,H18,H20, H21,H24,H25,H26,H27,H28,MMM	
17	PAOZZ	5970002215301	71124	TURBOLEX76B	.INSULATION SLEEVING USBL EFF 1 THRU 99,999.....	2
					UOC:H11,H13,H14,H15,H16,H17,H18,H20, H21,H24,H25,H26,H27,H28,MMM	
18	PAOZZ	9905008933570	81349	M43436/1-3	.BAND,MARKER USBL EFF 1 THRU 99,999	2
					UOC:H11,H13,H14,H15,H16,H17,H18,H20, H21,H24,H25,H26,H27,H28,MMM	
19	PAOZZ	5940001155006	96906	MS25036-133	.TERMINAL,LUG UABL EFF 1 THRU 99, 999.....	1
					UOC:H11,H13,H14,H15,H16,H17,H18,H20, H21,H24,H25,H26,H27,H28,MMM	
20	PAOZZ	5940001434794	96906	MS25036-112	TERMINAL,LUG USBL EFF 100,000 AND ABOVE.....	2
					UOC:AVY,A11,A13,A14,A15,A20,A24,A25, A26,A27,B16,B17,B18,HVY,H11,H13,H14, H15,H16,H17,H18,H20,H21,H24,H25,H26, H27,H28,MMM	
21	PAOZZ	5305009846192	96906	MS35206-244	SCREW,MACHINE #8-32 X 11.125,USBL EFF 100,000 AND ABOVE.....	1
					UOC:AVY,A11,A13,A14,A15,A20,A24,A25, A26,A27,B16,B17,B18,HVY,H11,H13,H14, H15,H16,H17,H18,H20,H21,H24,H25,H26, H27,H28,MMM	
22	MOOZZ		81755	P5006-4G-9	FIBER ROPE ASSEMBLY MAKE FROM CORD, P/N P5006-4G,9 INCHES LONG,USBL EFF 100,000 AND ABOVE.....	1
					UOC:AVY,A11,A13,A14,A15,A20,A24,A25, A26,A27,B16,B17,B18,HVY,H11,H13,H14, H15,H16,H17,H18,H20,H21,H24,H25,H26, H27,H28,MMM	
23	PAOZZ	5340013157223	19207	12342306	CAP,PROTECTIVE,DUST USBL EFF 100, 000 AND ABOVE.....	1
					UOC:AVY,A11,A13,A14,A15,A20,A24,A25, A26,A27,B16,B17,B18,HVY,H11,H13,H14, H15,H16,H17,H18,H20,H21,H24,H25,H26, H27,H28,MMM	
24	PAOZZ	5331002979990	96906	MS28775-222	O-RING USBL EFF 100,000 AND ABOVE..	1
					UOC:AVY,A11,A13,A14,A15,A20,A24,A25,	

SECTION II			TM9-2320-280-24P			
(1)	(2)	(3)	(4)	(5)	(6)	(7)
ITEM	SMR			PART		
NO	CODE	NSN	CAGEC	NUMBER	DESCRIPTION AND USABLE ON CODES(UC)	QTY
25	PAOZZ	6150013175853	19207	12342303	A26,A27,B16,B17,B18,HVY,H11,H13,H14, H15,H16,H17,H18,H20,H21,H24,H25,H26, H27,H28,MMM CABLE ASSEMBLY,POWE USBL EFF 100, 000 AND ABOVE..... UC:AVY,A11,A13,A14,A15,A20,A24,A25, A26,A27,B16,B17,B18,HVY,H11,H13,H14, H15,H16,H17,H18,H20,H21,H24,H25,H26, H27,H28,MMM	1

END OF FIGURE

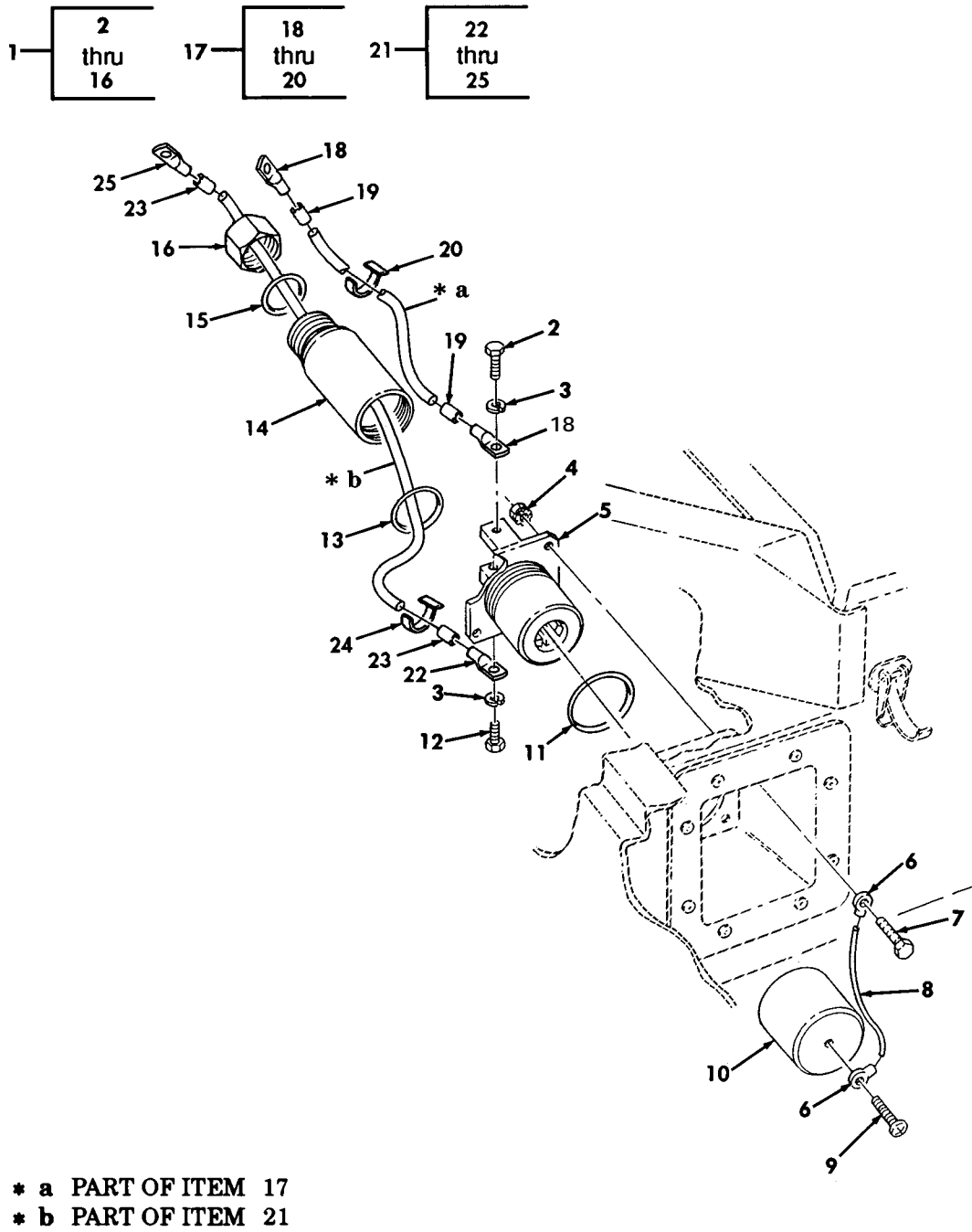

Figure 73. Slave Receptacle and Cable Assemblies.

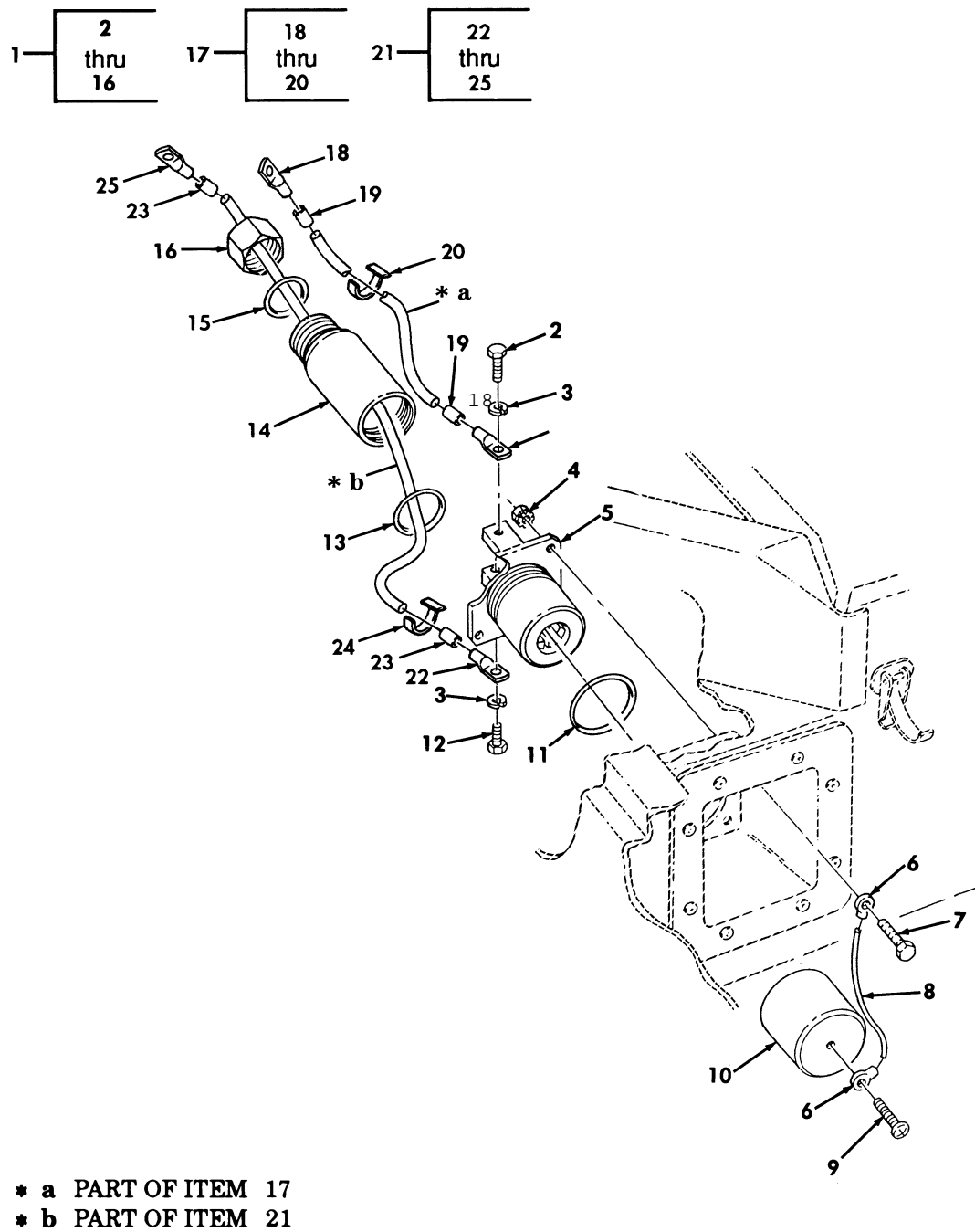

Figure 73. Slave Receptacle and Cable Assemblies.

SECTION II			TM9-2320-280-24P			
(1)	(2)	(3)	(4)	(5)	(6)	(7)
ITEM NO	SMR CODE	NSN	CAGEC	PART NUMBER	DESCRIPTION AND USABLE ON CODES(UOC)	QTY
GROUP 0612 BATTERIES,STORAGE						
FIG. 73 SLAVE RECEPTACLE AND CABLE ASSEMBLIES						
1	PAOZZ	5935013842610	19207	12342917	CONNECTOR ASSEMBLY USBL EFF 100,000 AND ABOVE.....	1
2	PAOZZ	5305004780273	96906	MS35307-355	.SCREW,CAP,HEXAGON H USBL EFF 100,000 AND ABOVE.....	1
3	PAOZZ	5310009847042	96906	MS35338-141	.WASHER,LOCK USBL EFF 100,000 AND ABOVE.....	2
4	PAOZZ	5310012041039	7X677	272474	.NUT,PLAIN,ASSEMBLED USBL EFF 100,000 AND ABOVE.....	4
5	PAOZZ	5935013973813	19207	12342920	.CONNECTOR,RECEPTACL USBL EFF 100,000 AND ABOVE.....	1
6	PAOZZ	5940001434794	96906	MS25036-112	.TERMINAL,LUG USBL EFF 100,000 AND ABOVE.....	2
7	PAOZZ	5305011879555	7X677	9415786	.SCREW,CAP,HEXAGON H USBL EFF 100,000 AND ABOVE.....	4
8	MOOZZ		81755	P5006-4G-9	.CORD,FIBROUS SLAVE USBL EFF 100,000 AND ABOVE,MAKE FROM CORD,P/N P5006-4G,9 INCHES LONG.....	1
9	PAOZZ	5305009846192	96906	MS35206-244	.SCREW,MACHINE USBL EFF 100,000 AND ABOVE.....	1
10	PAOZZ	5340013157223	19207	12342306	.CAP,PROTECTIVE,DUST USBL EFF 100,000 AND ABOVE.....	1
11	PAOZZ	5331013921793	81349	M83461/1-030	.O-RING USBL EFF 100,000 AND ABOVE.....	1
12	PAOZZ	5305006559711	96906	MS35307-357	.SCREW,CAP,HEXAGON H USBL EFF 100,000 AND ABOVE.....	1
13	PAOZZ	5331013363236	81349	M83461/1-029	.O-RING USBL EFF 100,000 AND ABOVE.....	1
14	PAOZZ	5935013963991	19207	12342924	.BACKSHELL,DUMMY CON USBL EFF 100,000 AND ABOVE.....	1
15	PAOZZ	5331013920830	81349	M83461/1-208	.O-RING USBL EFF 100,000 AND ABOVE.....	1
16	PAOZZ	5310014069129	19207	12342925	.NUT,PLAIN,HEXAGON USBL EFF 100,000 AND ABOVE.....	1
17	MOOOO		19207	12339322	CABLE ASSEMBLY USBL EFF 100,000 AND ABOVE MAKE FROM WIRE,P/N M13486/1-14,32 INCHES LONG.....	1
18	PAOZZ	5940007056732	11083	3M9449	.TERMINAL,LUG USBL EFF 100,000 AND ABOVE.....	2
19	PAOZZ	5970011749449	19207	7056640	.INSULATION SLEEVING USBL EFF 100,000 AND ABOVE.....	2
20	PAOZZ	9905008933570	81349	M43436/1-3	.BAND,MARKER USBL EFF 100,000 AND ABOVE.....	2
21	MOOOO		19207	12339321	CABLE ASSEMBLY USBL EFF 100,000 AND ABOVE MAKE FROM WIRE,P/N M13486/1-14,36 INCHES LONG.....	1
22	PAOZZ	5940007056732	11083	3M9449	.TERMINAL,LUG USBL EFF 100,000 AND ABOVE.....	1
23	PAOZZ	5970011749449	19207	7056640	.INSULATION SLEEVING USBL EFF 100,000 AND ABOVE.....	2
24	PAOZZ	9905008933570	81349	M43436/1-3	.BAND,MARKER USBL EFF 100,000 AND ABOVE.....	2
25	PAOZZ	5940007355520	56501	TG33	.TERMINAL,LUG USBL EFF 100,000 AND ABOVE.....	1

END OF FIGURE



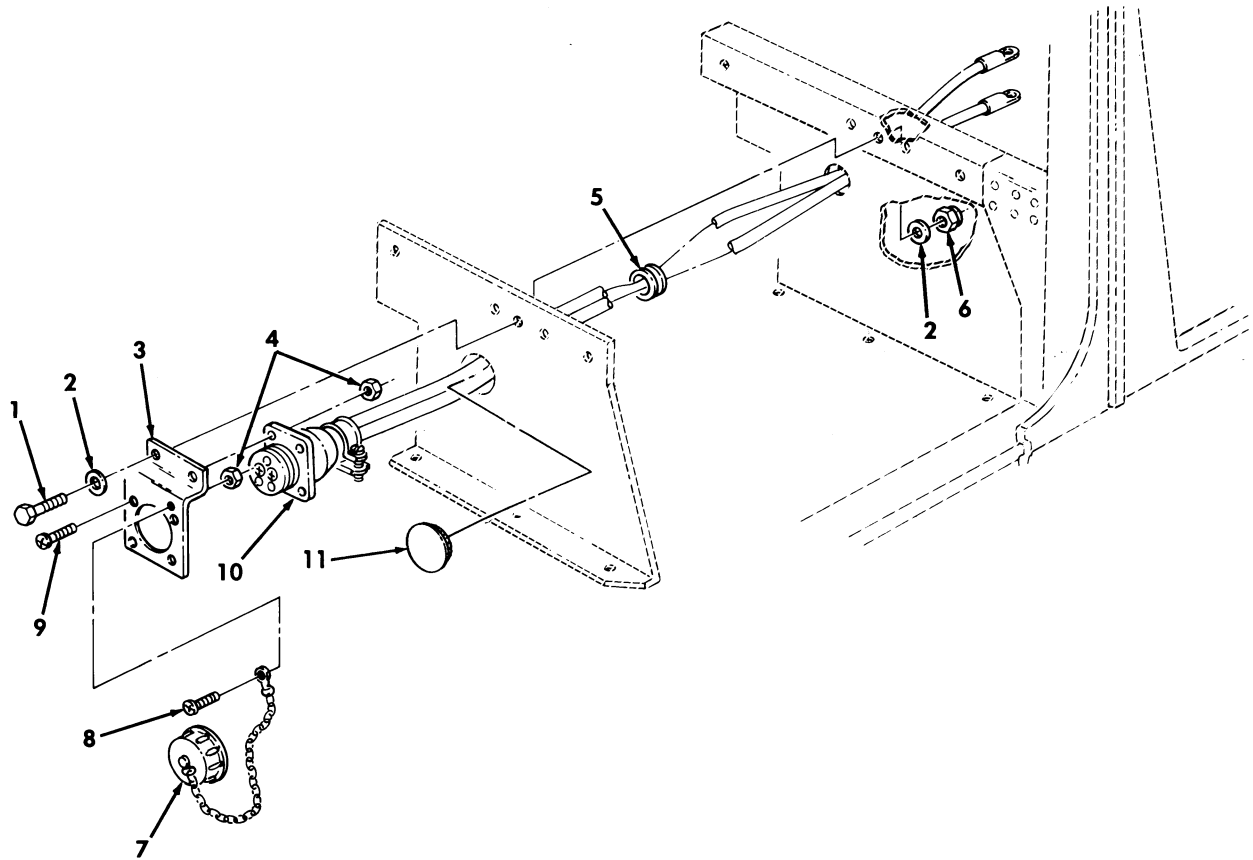

Figure 74. 200 AMP Umbilical Power Cable.

SECTION II			TM9-2320-280-24P			
(1)	(2)	(3)	(4)	(5)	(6)	(7)
ITEM	SMR			PART		
NO	CODE	NSN	CAGEC	NUMBER	DESCRIPTION AND USABLE ON CODES(UCO)	QTY
GROUP 0612 GENERATOR, ALTERNATOR						
FIG. 74 200 AMP UMBILICAL POWER CABLE						
1	PAOZZ	5306002258499	96906	MS90725-34	BOLT,MACHINE 5/16-18 X 1.00.....	2
					UCO:AVY,BVY,HVY,NNN	
2	PAOZZ	5310000814219	96906	MS27183-12	WASHER,FLAT 5/16.....	4
					UCO:AVY,BVY,HVY,NNN	
3	PFOZZ	5340013586697	19207	12342658	BRACKET,DOUBLE ANGL.....	1
					UCO:AVY,BVY,HVY,NNN	
4	PAOZZ	5310010695243	72582	271163	NUT,PLAIN,ASSEMBLED #8-32.....	5
					UCO:AVY,BVY,HVY,NNN	
5	PAOZZ	5325012897859	28520	2400	GROMMET,NONMETALLIC.....	1
					UCO:AVY,BVY,HVY,NNN	
6	PAOZZ	5310008140673	96906	MS51943-33	NUT,SELF-LOCKING,HE 5/16-18.....	2
					UCO:AVY,BVY,HVY,NNN	
7	PAOZZ	5935012239420	96906	MS25043-32DA	COVER,ELECTRICAL CO.....	1
					UCO:AVY,BVY,HVY,NNN	
8	PAOZZ	5305013590167	24617	159612	SCREW,MACHINE #8-32 X .625.....	1
					UCO:AVY,BVY,HVY,NNN	
9	PAOZA	5305010358766	80205	NAS387-832-12P	SCREW,MACHINE #8-32 X .750.....	4
					UCO:AVY,BVY,HVY,NNN	
10	PAOZZ	6150013618129	09647	07687-2	LEAD,ELECTRICAL.....	1
					UCO:AVY,BVY,HVY,NNN	
11	PAOZA	5340010381493	24617	454253	BUTTON,PLUG.....	1
					UCO:AVY,BVY,HVY,NNN	

END OF FIGURE

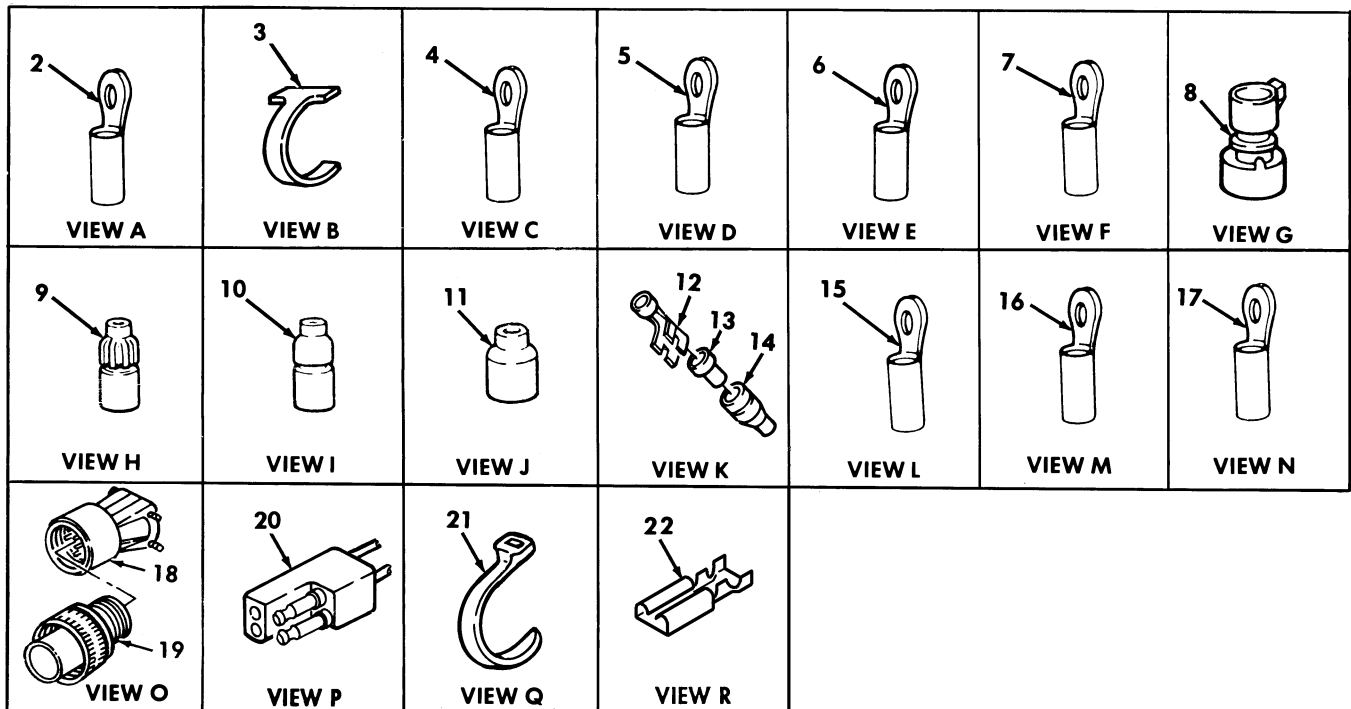
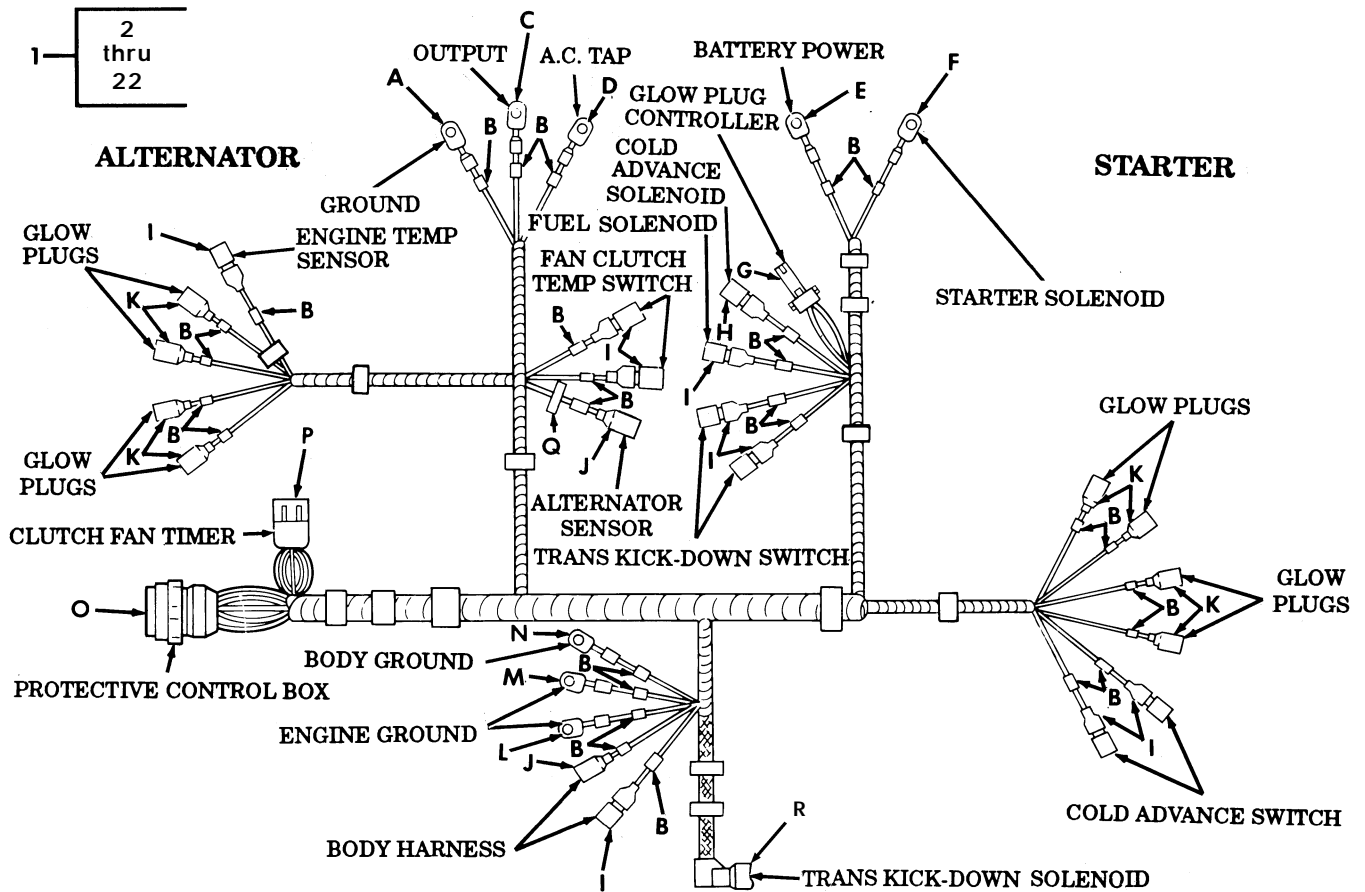

Figure 75. Engine Wiring Harness (Sheet 1 of 2).

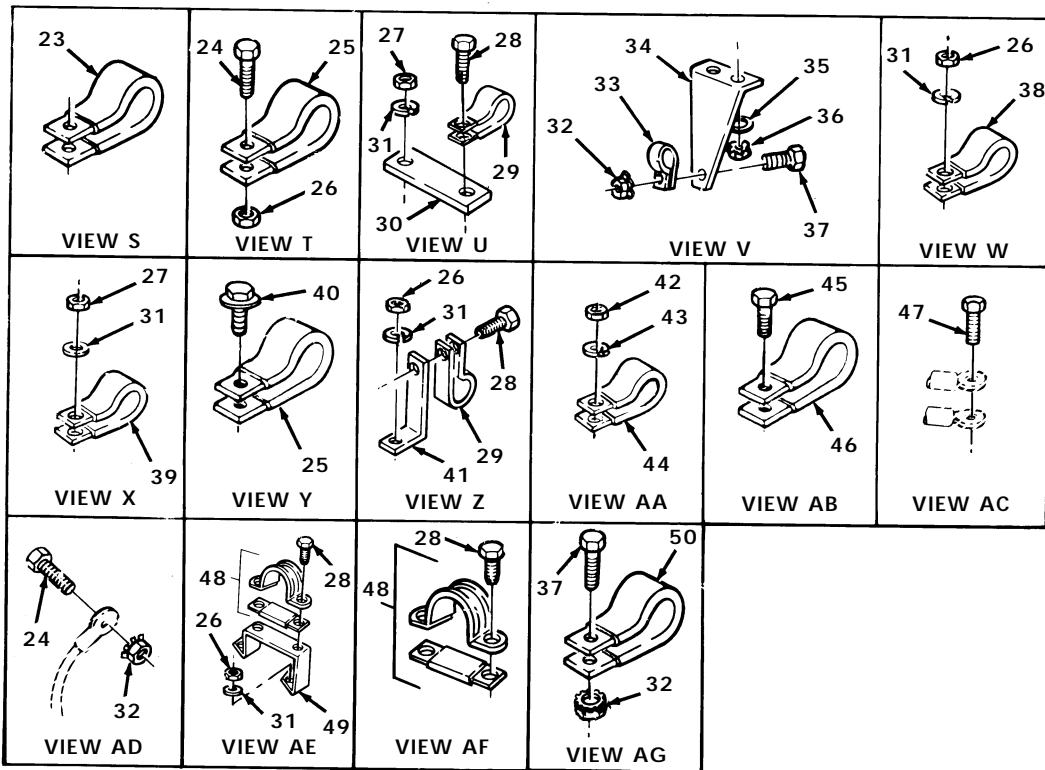
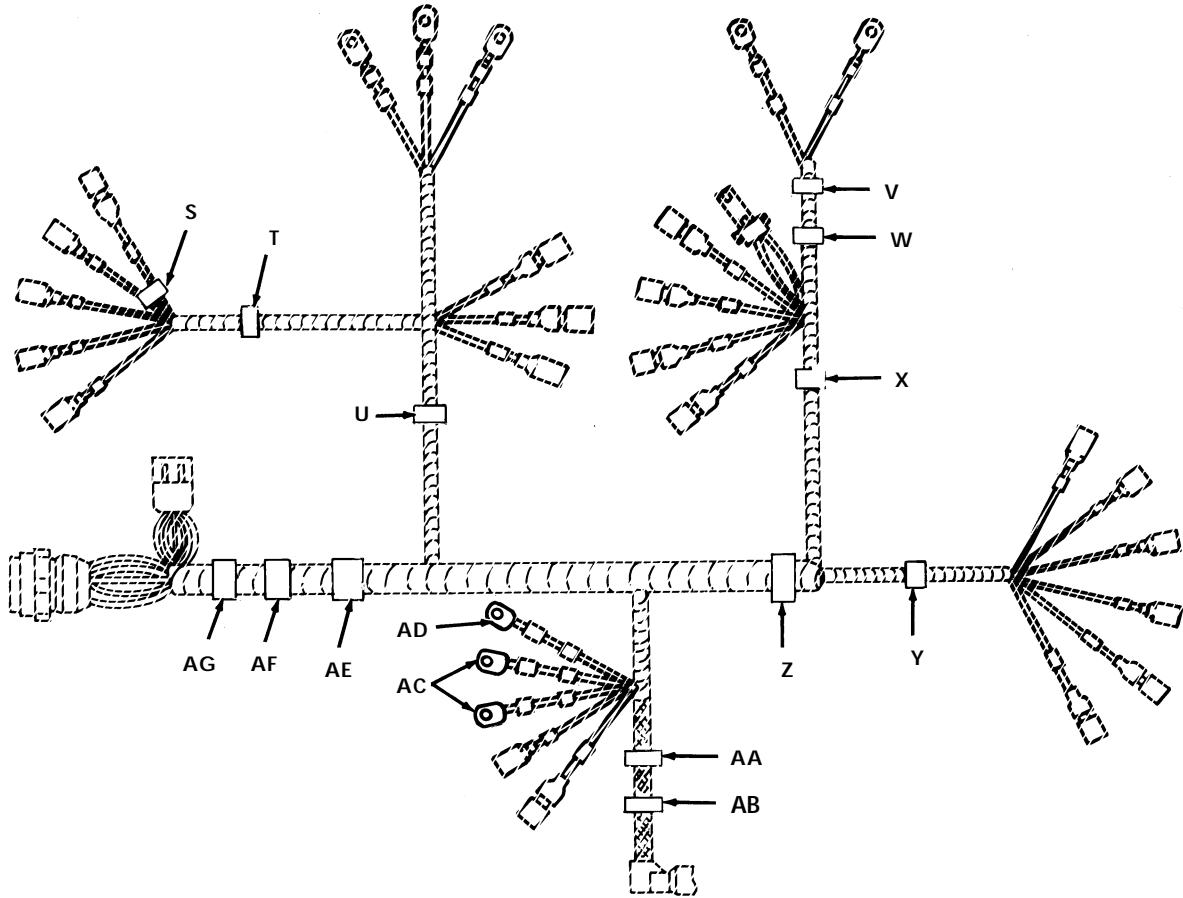

Figure 75. Engine Wiring Harness (Sheet 2 of 2).

SECTION II			TM9-2320-280-24P			
(1)	(2)	(3)	(4)	(5)	(6)	(7)
ITEM	SMR			PART		
NO	CODE	NSN	CAGEC	NUMBER	DESCRIPTION AND USABLE ON CODES(UOC)	QTY
					GROUP 0613 HULL OR CHASSIS WIRING HARNESS	
					FIG. 75 ENGINE WIRING HARNESS	
1	PAFFF	5995011845545	19207	12339350	WIRING HARNESS,BRAN 6.2 LITER..... UOC:AVY,A11,A13,A14,A15,A20,A24,A25, A26,A27,B16,B17,B18,HVY,H11,H13,H14, H15,H16,H17,H18,H20,H21,H24,H25,H26, H27,H28,MMM	1
2	PAOZZ	5940007056714	56501	TG14	. TERMINAL, LUG..... UOC:AVY,A11,A13,A14,A15,A20,A24,A25, A26,A27,B16,B17,B18,HVY,H11,H13,H14, H15,H16,H17,H18,H20,H21,H24,H25,H26, H27,H28,MMM	1
3	PAOZZ	9905010138723	81349	M43436/3-1	. BAND, MARKER..... UOC:AVY,A11,A13,A14,A15,A20,A24,A25, A26,A27,B16,B17,B18,HVY,H11,H13,H14, H15,H16,H17,H18,H20,H21,H24,H25,H26, H27,H28,MMM	28
4	PAOZZ	5940001139825	96906	MS20659-141	. TERMINAL, LUG..... UOC:AVY,A11,A13,A14,A15,A20,A24,A25, A26,A27,B16,B17,B18,HVY,H11,H13,H14, H15,H16,H17,H18,H20,H21,H24,H25,H26, H27,H28,MMM	1
5	PAOZZ	5940001071481	96906	MS20659-104	. TERMINAL, LUG..... UOC:AVY,A11,A13,A14,A15,A20,A24,A25, A26,A27,B16,B17,B18,HVY,H11,H13,H14, H15,H16,H17,H18,H20,H21,H24,H25,H26, H27,H28,MMM	1
6	PAOZZ	5940012022682	19207	12339716	. TERMINAL, LUG..... UOC:AVY,A11,A13,A14,A15,A20,A24,A25, A26,A27,B16,B17,B18,HVY,H11,H13,H14, H15,H16,H17,H18,H20,H21,H24,H25,H26, H27,H28,MMM	1
7	PAOZZ	5940007056708	56501	TG8	. TERMINAL, LUG..... UOC:AVY,A11,A13,A14,A15,A20,A24,A25, A26,A27,B16,B17,B18,HVY,H11,H13,H14, H15,H16,H17,H18,H20,H21,H24,H25,H26, H27,H28,MMM	1
8	PFOZZ	5970011809776	19207	12339503	. INSULATOR, STANDOFF..... UOC:AVY,A11,A13,A14,A15,A20,A24,A25, A26,A27,B16,B17,B18,HVY,H11,H13,H14, H15,H16,H17,H18,H20,H21,H24,H25,H26, H27,H28,MMM	1
9	PAOZA	5935001846707	96906	MS27144-3	. CONNECTOR, PLUG, ELEC..... UOC:AVY,A11,A13,A14,A15,A20,A24,A25, A26,A27,B16,B17,B18,HVY,H11,H13,H14, H15,H16,H17,H18,H20,H21,H24,H25,H26, H27,H28,MMM	1
10	PAOZA	5935001677775	96906	MS27144-1	. CONNECTOR, PLUG, ELEC..... UOC:AVY,A11,A13,A14,A15,A20,A24,A25, A26,A27,B16,B17,B18,HVY,H11,H13,H14,	9

SECTION II			TM9-2320-280-24P			
(1)	(2)	(3)	(4)	(5)	(6)	(7)
ITEM NO	SMR CODE	NSN	CAGEC	PART NUMBER	DESCRIPTION AND USABLE ON CODES(UOC)	QTY
11	PAOZZ	5935004626603	96906	MS27142-2	H15, H16, H17, H18, H20, H21, H24, H25, H26, H27, H28, MMM .CONNECTOR, PLUG, ELEC.....	2
12	PAOZZ	5940003996676	19207	8338564	UOC:AVY, A11, A13, A14, A15, A20, A24, A25, A26, A27, B16, B17, B18, HVY, H11, H13, H14, H15, H16, H17, H18, H20, H21, H24, H25, H26, H27, H28, MMM . TERMINAL SET, QUICK.....	8
13	PAOZZ	5970008338562	19207	8338562	UOC:AVY, A11, A13, A14, A15, A20, A24, A25, A26, A27, B16, B17, B18, HVY, H11, H13, H14, H15, H16, H17, H18, H20, H21, H24, H25, H26, H27, H28, MMM . INSULATOR, BUSHING.....	8
14	PAOZZ	5975012071706	19207	12339334	UOC:AVY, A11, A13, A14, A15, A20, A24, A25, A26, A27, B16, B17, B18, HVY, H11, H13, H14, H15, H16, H17, H18, H20, H21, H24, H25, H26, H27, H28, MMM .CABLE NIPPLE, ELECTR.....	8
15	PAOZZ	5940007056715	56501	TG15	UOC:AVY, A11, A13, A14, A15, A20, A24, A25, A26, A27, B16, B17, B18, HVY, H11, H13, H14, H15, H16, H17, H18, H20, H21, H24, H25, H26, H27, H28, MMM . TERMINAL, LUG.....	1
16	PAOZZ	5940007056711	56501	TG11	UOC:AVY, A11, A13, A14, A15, A20, A24, A25, A26, A27, B16, B17, B18, HVY, H11, H13, H14, H15, H16, H17, H18, H20, H21, H24, H25, H26, H27, H28, MMM . TERMINAL, LUG.....	1
17	PAOZZ	5940007056703	56501	TG3	UOC:AVY, A11, A13, A14, A15, A20, A24, A25, A26, A27, B16, B17, B18, HVY, H11, H13, H14, H15, H16, H17, H18, H20, H21, H24, H25, H26, H27, H28, MMM . TERMINAL, LUG.....	1
18	PAOZA	5935011737654	96906	MS3456W24-11S	UOC:AVY, A11, A13, A14, A15, A20, A24, A25, A26, A27, B16, B17, B18, HVY, H11, H13, H14, H15, H16, H17, H18, H20, H21, H24, H25, H26, H27, H28, MMM .CONNECTOR, PLUG, ELEC.....	1
19	PAOZZ	5935011743669	81349	M85049/52-1-24W	UOC:AVY, A11, A13, A14, A15, A20, A24, A25, A26, A27, B16, B17, B18, HVY, H11, H13, H14, H15, H16, H17, H18, H20, H21, H24, H25, H26, H27, H28, MMM . CLAMP, CABLE, ELECTRI.....	1
20	PAOZZ	5935014154392	19207	12342712	UOC:AVY, A11, A13, A14, A15, A20, A24, A25, A26, A27, B16, B17, B18, HVY, H11, H13, H14, H15, H16, H17, H18, H20, H21, H24, H25, H26, H27, H28, MMM . INSERT, ELECTRICAL C.....	1
21	PAOZZ	5975009856630	96906	MS3367-3-0	UOC:AVY, A11, A13, A14, A15, A20, A24, A25, A26, A27, B16, B17, B18, HVY, H11, H13, H14, H15, H16, H17, H18, H20, H21, H24, H25, H26, H27, H28, MMM . STRAP, TIEDOWN, ELECT.....	1

SECTION II			TM9-2320-280-24P			
(1)	(2)	(3)	(4)	(5)	(6)	(7)
ITEM NO	SMR CODE	NSN	CAGEC	PART NUMBER	DESCRIPTION AND USABLE ON CODES(UC)	QTY
22	PAOZZ		91094	371230-B01	UOC:AVY,A11,A13,A14,A15,A20,A24,A25,A26,A27,B16,B17,B18,HVY,H11,H13,H14,H15,H16,H17,H18,H20,H21,H24,H25,H26,H27,H28,MMM . TERMINAL, RECEPTACLE.....	1
23	PAFZZ	5340008091490	96906	MS21333-98	UOC:AVY,A11,A13,A14,A15,A20,A24,A25,A26,A27,B16,B17,B18,HVY,H11,H13,H14,H15,H16,H17,H18,H20,H21,H24,H25,H26,H27,H28,MMM CLAMP, LOOP.....	1
24	PAFZZ	5305005829501	82386	410-63	UOC:AVY,A11,A13,A14,A15,A20,A24,A25,A26,A27,B16,B17,B18,HVY,H11,H13,H14,H15,H16,H17,H18,H20,H21,H24,H25,H26,H27,H28,MMM SCREW,CAP,HEXAGON H #10-32 X 1/2...	2
25	PAFZZ	5340000572904	96906	MS21333-71	UOC:AVY,A11,A13,A14,A15,A20,A24,A25,A26,A27,B16,B17,B18,HVY,H11,H13,H14,H15,H16,H17,H18,H20,H21,H24,H25,H26,H27,H28,MMM CLAMP, LOOP.....	2
26	PAFZZ	5310001249265	72582	271169	UOC:AVY,A11,A13,A14,A15,A20,A24,A25,A26,A27,B16,B17,B18,HVY,H11,H13,H14,H15,H16,H17,H18,H20,H21,H24,H25,H26,H27,H28,MMM NUT,PLAIN,ASSEMBLED #10-32.....	4
27	PAFZZ	5310011552503	7X677	11514603	UOC:AVY,A11,A13,A14,A15,A20,A24,A25,A26,A27,B16,B17,B18,HVY,H11,H13,H14,H15,H16,H17,H18,H20,H21,H24,H25,H26,H27,H28,MMM NUT,PLAIN,HEXAGON 10 MM.....	2
28	PAFZZ	5305012068401	34623	5592954	UOC:AVY,A11,A13,A14,A15,A20,A24,A25,A26,A27,B16,B17,B18,HVY,H11,H13,H14,H15,H16,H17,H18,H20,H21,H24,H25,H26,H27,H28,MMM SCREW,TAPPING 1/4-28 X 1/2.....	6
29	PAFZZ	5340008091494	96906	MS21333-105	UOC:AVY,A11,A13,A14,A15,A20,A24,A25,A26,A27,B16,B17,B18,HVY,H11,H13,H14,H15,H16,H17,H18,H20,H21,H24,H25,H26,H27,H28,MMM CLAMP, LOOP.....	2
30	PAFZZ	5340012124716	19207	12339335	UOC:AVY,A11,A13,A14,A15,A20,A24,A25,A26,A27,B16,B17,B18,HVY,H11,H13,H14,H15,H16,H17,H18,H20,H21,H24,H25,H26,H27,H28,MMM BRACKET,ANGLE.....	1
31	PAFZZ	5310012067306	7X677	11500207	UOC:AVY,A11,A13,A14,A15,A20,A24,A25,A26,A27,B16,B17,B18,HVY,H11,H13,H14,H15,H16,H17,H18,H20,H21,H24,H25,H26,H27,H28,MMM WASHER, LOCK 10MM.....	6

SECTION II			TM9-2320-280-24P			
(1)	(2)	(3)	(4)	(5)	(6)	(7)
ITEM NO	SMR CODE	NSN	CAGEC	PART NUMBER	DESCRIPTION AND USABLE ON CODES(UOC)	QTY
32	PAFZZ	5310012522999	34623	5593033	H27, H28, MMM NUT, SELF-LOCKING, AS 1/4-20.....	2
					UOC:AVY, A11, A13, A14, A15, A20, A24, A25, A26, A27, B16, B17, B18, HVY, H11, H13, H14, H15, H16, H17, H18, H20, H21, H24, H25, H26, H27, H28, MMM	
33	PAFZZ	5340000881254	96906	MS21333-104	CLAMP, LOOP.....	1
					UOC:AVY, A11, A13, A14, A15, A20, A24, A25, A26, A27, B16, B17, B18, HVY, H11, H13, H14, H15, H16, H17, H18, H20, H21, H24, H25, H26, H27, H28, MMM	
34	PFFZZ	5340012097387	19207	12339333	BRACKET, ANGLE.....	1
					UOC:AVY, A11, A13, A14, A15, A20, A24, A25, A26, A27, B16, B17, B18, HVY, H11, H13, H14, H15, H16, H17, H18, H20, H21, H24, H25, H26, H27, H28, MMM	
35	PAFZZ	5310005825965	96906	MS35338-44	WASHER, LOCK 6MM.....	2
					UOC:AVY, A11, A13, A14, A15, A20, A24, A25, A26, A27, B16, B17, B18, HVY, H11, H13, H14, H15, H16, H17, H18, H20, H21, H24, H25, H26, H27, H28, MMM	
36	PAFZZ	5310011586257	7X677	11503739	NUT, PLAIN, HEXAGON 6MM X 1.....	2
					UOC:AVY, A11, A13, A14, A15, A20, A24, A25, A26, A27, B16, B17, B18, HVY, H11, H13, H14, H15, H16, H17, H18, H20, H21, H24, H25, H26, H27, H28, MMM	
37	PAFZZ	5305009881725	96906	MS35206-281	SCREW, MACHINE 1/4-20 X 3/4.....	2
					UOC:AVY, A11, A13, A14, A15, A20, A24, A25, A26, A27, B16, B17, B18, HVY, H11, H13, H14, H15, H16, H17, H18, H20, H21, H24, H25, H26, H27, H28, MMM	
38	PAFZZ	5340007255280	96906	MS21333-125	CLAMP, LOOP.....	1
					UOC:AVY, A11, A13, A14, A15, A20, A24, A25, A26, A27, B16, B17, B18, HVY, H11, H13, H14, H15, H16, H17, H18, H20, H21, H24, H25, H26, H27, H28, MMM	
39	PAFZZ	5340000538994	96906	MS21333-126	CLAMP, LOOP.....	1
					UOC:AVY, A11, A13, A14, A15, A20, A24, A25, A26, A27, B16, B17, B18, HVY, H11, H13, H14, H15, H16, H17, H18, H20, H21, H24, H25, H26, H27, H28, MMM	
40	PAFZZ	5305012155174	19207	12340515	SCREW, ASSEMBLED WAS.....	1
					UOC:AVY, A11, A13, A14, A15, A20, A24, A25, A26, A27, B16, B17, B18, HVY, H11, H13, H14, H15, H16, H17, H18, H20, H21, H24, H25, H26, H27, H28, MMM	
41	PFFZZ	5340012065540	19207	12339336	BRACKET, ANGLE.....	1
					UOC:AVY, A11, A13, A14, A15, A20, A24, A25, A26, A27, B16, B17, B18, HVY, H11, H13, H14, H15, H16, H17, H18, H20, H21, H24, H25, H26, H27, H28, MMM	
42	PAFZZ	5310007320558	96906	MS51967-8	NUT, PLAIN, HEXAGON 3/8-16.....	1
					UOC:AVY, A11, A13, A14, A15, A20, A24, A25,	



SECTION II			TM9-2320-280-24P			
(1)	(2)	(3)	(4)	(5)	(6)	(7)
ITEM NO	SMR CODE	NSN	CAGEC	PART NUMBER	DESCRIPTION AND USABLE ON CODES(UOC)	QTY
					A26,A27,B16,B17,B18,HVY,H11,H13,H14,H15,H16,H17,H18,H20,H21,H24,H25,H26,H27,H28,MMM	
43	PAFZZ	5310006379541	96906	MS35338-46	WASHER, LOCK 3/8.....	1
					UOC:AVY,A11,A13,A14,A15,A20,A24,A25,A26,A27,B16,B17,B18,HVY,H11,H13,H14,H15,H16,H17,H18,H20,H21,H24,H25,H26,H27,H28,MMM	
44	PAFZZ	5340009645267	96906	MS21333-120	CLAMP, LOOP.....	1
					UOC:AVY,A11,A13,A14,A15,A20,A24,A25,A26,A27,HVY,H11,H13,H14,H15,H16,H17,H18,H20,H21,H24,H25,H26,H27,H28,MMM	
44	PAFZZ	5305007578122	96906	MS51851-64	SCREW, TAPPING #10-24 X 7/16.....	1
					UOC:AVY,A11,A13,A14,A15,A20,A24,A25,A26,A27,B16,B17,B18,HVY,H11,H13,H14,H15,H16,H17,H18,H20,H21,H24,H25,H26,H27,H28,MMM	
46	PAFZZ	5340000913790	96906	MS21333-72	CLAMP, LOOP.....	1
					UOC:AVY,A11,A13,A14,A15,A20,A24,A25,A26,A27,B16,B17,B18,HVY,H11,H13,H14,H15,H16,H17,H18,H20,H21,H24,H25,H26,H27,H28,MMM	
47	PAFZZ	5306012519190	34623	G-11501940	BOLT, MACHINE 10-1.5 X 20MM.....	1
					UOC:AVY,A11,A13,A14,A15,A20,A24,A25,A26,A27,B16,B17,B18,HVY,H11,H13,H14,H15,H16,H17,H18,H20,H21,H24,H25,H26,H27,H28,MMM	
48	PAFZZ	5340012134667	34623	5588785	STRAP, RETAINING.....	2
					UOC:AVY,A11,A13,A14,A15,A20,A24,A25,A26,A27,B16,B17,B18,HVY,H11,H13,H14,H15,H16,H17,H18,H20,H21,H24,H25,H26,H27,H28,MMM	
49	PAFZZ	5340011980480	19207	12339343	BRACKET, MOUNTING.....	1
					UOC:AVY,A11,A13,A14,A15,A20,A24,A25,A26,A27,B16,B17,B18,HVY,H11,H13,H14,H15,H16,H17,H18,H20,H21,H24,H25,H26,H27,H28,MMM	
50	PAFZZ	5340008091500	96906	MS21333-107	CLAMP, LOOP.....	1
					UOC:AVY,A11,A13,A14,A15,A20,A24,A25,A26,A27,B16,B17,B18,HVY,H11,H13,H14,H15,H16,H17,H18,H20,H21,H24,H25,H26,H27,H28,MMM	

END OF FIGURE

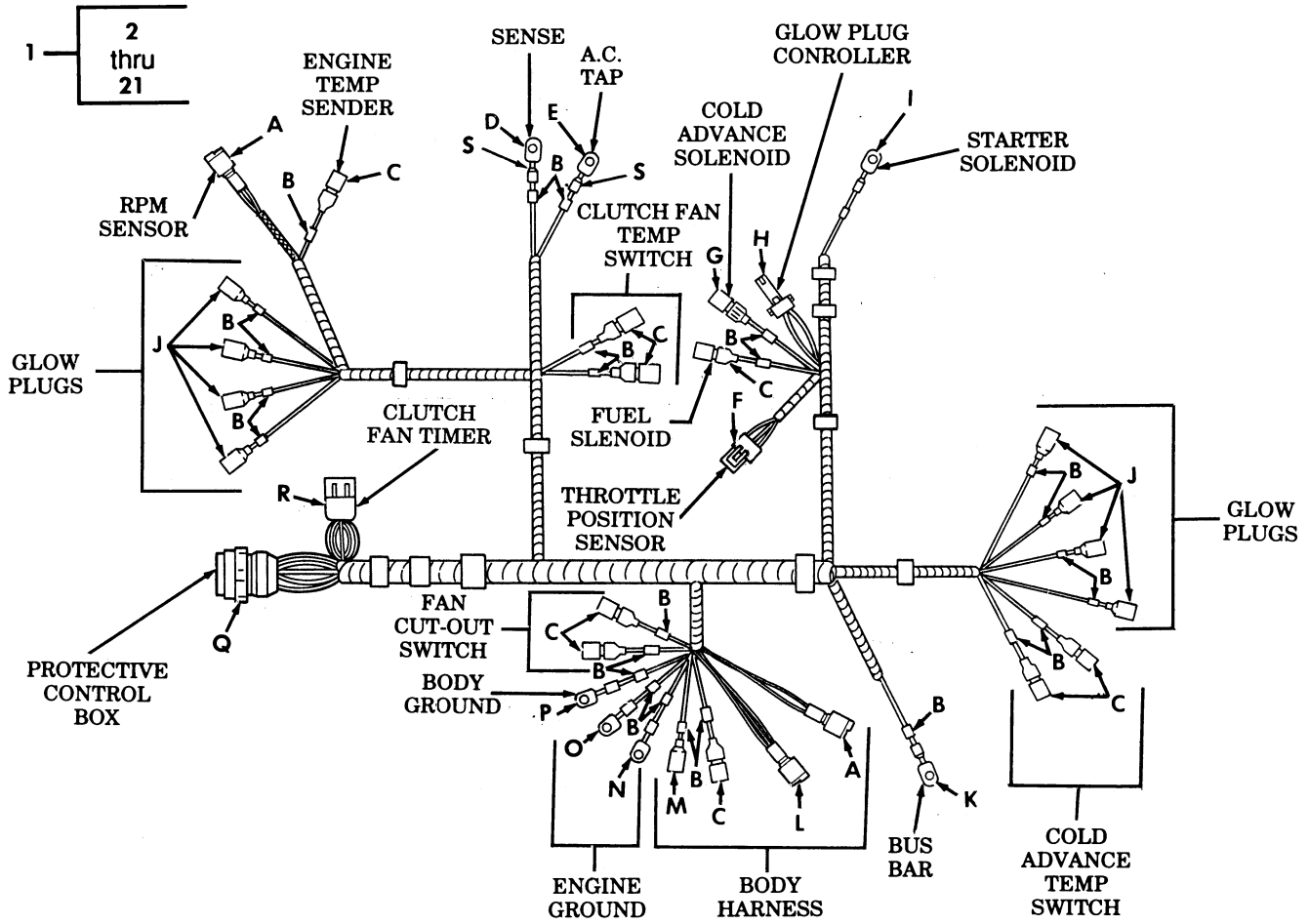

<p>VIEW A</p>	<p>VIEW B</p>	<p>VIEW C</p>	<p>VIEW D</p>	<p>VIEW E</p>	<p>VIEW F</p>	<p>VIEW G</p>
<p>VIEW H</p>	<p>VIEW I</p>	<p>VIEW J</p>	<p>VIEW K</p>	<p>VIEW L</p>	<p>VIEW M</p>	<p>VIEW N</p>
<p>VIEW O</p>	<p>VIEW P</p>	<p>VIEW Q</p>	<p>VIEW R</p>	<p>VIEW S</p>		

Figure 76. A2 Engine Wiring Harness.

SECTION II			TM9-2320-280-24P			
(1)	(2)	(3)	(4)	(5)	(6)	(7)
ITEM NO	SMR CODE	NSN	CAGEC	PART NUMBER	DESCRIPTION AND USABLE ON CODES(UOC)	QTY
GROUP 0613 HULL OR CHASIS WIRING HARNESS						
FIG. 76 A2 ENIGNE WIRING HARNESS						
1	PFFFF	6150014123192	19207	12446828	HARNESS,ENGINE COMP 6.5 LITER.....	1
					UOC:BVY,B15,B20,B24,B25,C17,NNN	
2	PAOZZ	5935011495165	11083	7N9738	.CONNECTOR BODY,PLUG.....	2
					UOC:BVY,B15,B20,B24,B25,C17,NNN	
3	PAOZZ	9905010138723	81349	M43436/3-1	.BAND,MARKER.....	25
					UOC:BVY,B15,B20,B24,B25,C17,NNN	
4	PAOZZ	5935001677775	96906	MS27144-1	.CONNECTOR,PLUG,ELEC.....	9
					UOC:BVY,B15,B20,B24,B25,C17,NNN	
5	PAOZZ	5940007056709	56501	TG9	.TERMINAL,LUG.....	1
					UOC:BVY,B15,B20,B24,B25,C17,NNN	
6	PAOZZ	5940001071481	96906	MS20659-104	.TERMINAL,LUG.....	1
					UOC:BVY,B15,B20,B24,B25,C17,NNN	
7	PAOZZ	5935014129146	19207	12460132	.CONNECTOR,PLUG,ELEC.....	1
					UOC:BVY,B15,B20,B24,B25,C17,NNN	
8	PAOZZ	5935001846707	96906	MS27144-3	.CONNECTOR,PLUG,ELEC.....	1
					UOC:BVY,B15,B20,B24,B25,C17,NNN	
9	PAOZZ	5935012168763	34623	5903101	.SOCKET,PLUG-IN ELEC.....	1
					UOC:BVY,B15,B20,B24,B25,C17,NNN	
10	PAOZZ	5940007056708	56501	TG8	.TERMINAL,LUG.....	1
					UOC:BVY,B15,B20,B24,B25,C17,NNN	
11	PAOZZ	5970008338562	19207	8338562	.INSULATOR,BUSHING.....	8
					UOC:BVY,B15,B20,B24,B25,C17,NNN	
12	PAOZZ	5940001141315	96906	MS20659-142	.TERMINAL,LUG.....	1
					UOC:BVY,B15,B20,B24,B25,C17,NNN	
13	PAOZZ	5935011539320	71468	120-1805-000	.CONNECTOR,PLUG,ELEC.....	1
					UOC:BVY,B15,B20,B24,B25,C17,NNN	
14	PAOZZ	5935004626603	96906	MS27142-2	.CONNECTOR,PLUG,ELEC.....	1
					UOC:BVY,B15,B20,B24,B25,C17,NNN	
15	PAOZZ	5940007056715	56501	TG15	.TERMINAL,LUG.....	1
					UOC:BVY,B15,B20,B24,B25,C17,NNN	
16	PAOZZ	5940007056711	56501	TG11	.TERMINAL,LUG.....	1
					UOC:BVY,B15,B20,B24,B25,C17,NNN	
17	PAOZZ	5940007056703	56501	TG3	.TERMINAL,LUG.....	1
					UOC:BVY,B15,B20,B24,B25,C17,NNN	
18	PAOZZ	5935014154322	19207	12342654	.CONNECTOR,PLUG,ELEC.....	1
					UOC:BVY,B15,B20,B24,B25,C17,NNN	
19	PAOZZ	5310014155245	19207	12342864	.NUT,PLAIN,ROUND.....	1
					UOC:BVY,B15,B20,B24,B25,C17,NNN	
20	PAOZZ	5935014154392	19207	12342712	.INSERT,ELECTRICAL C.....	1
					UOC:BVY,B15,B20,B24,B25,C17,NNN	
21	PAOZZ	5975014695558	77060	0298 4033	.CABLE NIPPLE,ELECTR.....	2
					UOC:BVY,B15,B20,B24,B25,C17,NNN	

END OF FIGURE

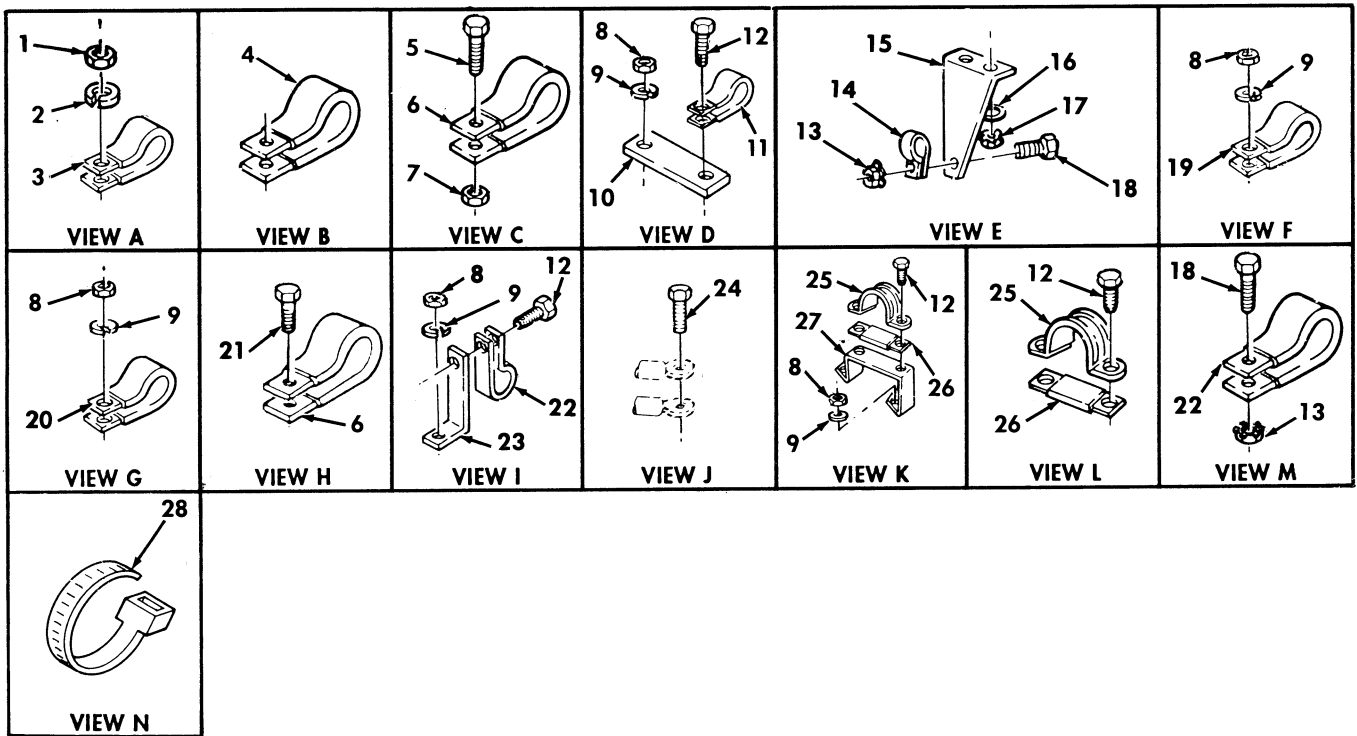
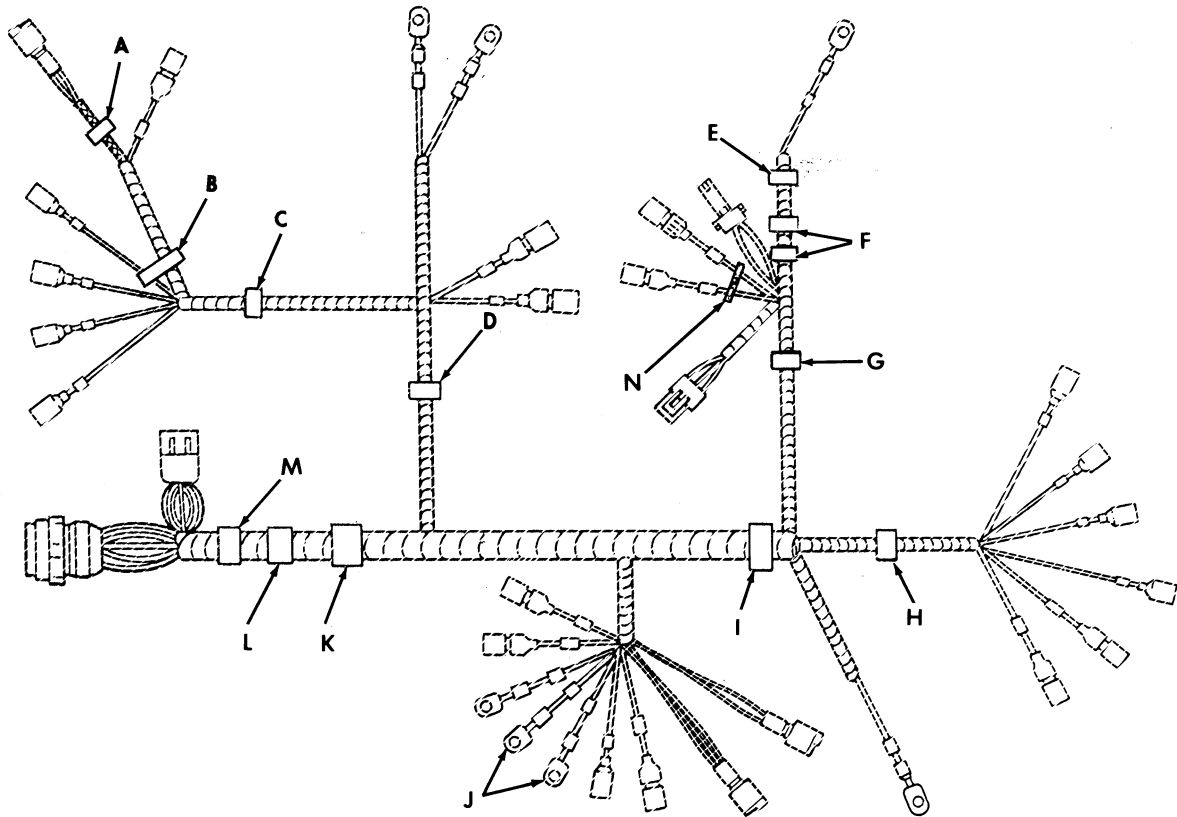

Figure 77. A2 Engine Wiring Harness Installation.

SECTION II			TM9-2320-280-24P			
(1)	(2)	(3)	(4)	(5)	(6)	(7)
ITEM NO	SMR CODE	NSN	CAGEC	PART NUMBER	DESCRIPTION AND USABLE ON CODES(UCO)	QTY
GROUP 0613 HULL OR CHASSIS WIRING HARNESS						
FIG. 77 A2 ENGINE WIRING HARNESS INSTALLATION						
1	PAFZZ	5310007320558	96906	MS51967-8	NUT,PLAIN,HEXAGON 3/8-16.....	1
					UCO:BVY,B15,B20,B24,B25,C17,NNN	
2	PAFZZ	5310006379541	96906	MS35338-46	WASHER,LOCK 3/8.....	1
					UCO:BVY,B15,B20,B24,B25,C17,NNN	
3	PAFZZ	5340009891771	96906	MS21333-123	CLAMP,LOOP.....	1
					UCO:BVY,B15,B20,B24,B25,C17,NNN	
4	PAFZZ	5340008091492	81348	CMDX2-3PT573036	CLAMP,LOOP.....	1
					UCO:BVY,B15,B20,B24,B25,C17,NNN	
5	PAFZZ	5305005829501	82386	410-63	SCREW,CAP,HEXAGON H #10-32 X .50...	1
					UCO:BVY,B15,B20,B24,B25,C17,NNN	
6	PAFZZ	5340000572904	96906	MS21333-71	CLAMP,LOOP.....	2
					UCO:BVY,B15,B20,B24,B25,C17,NNN	
7	PAFZZ	5310001249265	72582	271169	NUT,PLAIN,ASSEMBLED #10-32.....	1
					UCO:BVY,B15,B20,B24,B25,C17,NNN	
8	PAFZZ	5310013663539	80204	B18241B100F	NUT,PLAIN,HEXAGON 1/4-28.....	8
					UCO:BVY,B15,B20,B24,B25,C17,NNN	
9	PAFZZ	5310012067306	7X677	11500207	WASHER,LOCK 1/4.....	8
					UCO:BVY,B15,B20,B24,B25,C17,NNN	
10	PAFZZ	5340012124716	19207	12339335	BRACKET,ANGLE.....	1
					UCO:BVY,B15,B20,B24,B25,C17,NNN	
11	PAFZZ	5340007647052	96906	MS21333-116	CLAMP,LOOP.....	1
					UCO:BVY,B15,B20,B24,B25,C17,NNN	
12	PAFZZ	5305012068401	7X677	448655	SCREW,TAPPING 1/4-28 X 1/2.....	6
					UCO:BVY,B15,B20,B24,B25,C17,NNN	
13	PAFZZ	5310011520598	24617	271172	NUT,SELF-LOCKING,AS 1/4-20.....	2
					UCO:BVY,B15,B20,B24,B25,C17,NNN	
14	PAFZZ	5340009936207	96906	MS21333-99	CLAMP,LOOP.....	1
					UCO:BVY,B15,B20,B24,B25,C17,NNN	
15	PAFZZ	5340012097387	19207	12339333	BRACKET,ANGLE.....	1
					UCO:BVY,B15,B20,B24,B25,C17,NNN	
16	PAFZZ	5310014443084	24617	11503962	WASHER,LOCK 6MM.....	2
					UCO:BVY,B15,B20,B24,B25,C17,NNN	
17	PAFZZ	5310011586257	7X677	11503739	NUT,PLAIN,HEXAGON 6MM X 1.....	2
					UCO:BVY,B15,B20,B24,B25,C17,NNN	
18	PAFZZ	5305004890743	24617	9415477	SCREW,MACHINE 1/4-20 X 3/4.....	2
					UCO:BVY,B15,B20,B24,B25,C17,NNN	
19	PAFZZ	5340009645267	96906	MS21333-120	CLAMP,LOOP.....	2
					UCO:BVY,B15,B20,B24,B25,C17,NNN	
20	PAFZZ	5340007255280	96906	MS21333-125	CLAMP,LOOP.....	1
					UCO:BVY,B15,B20,B24,B25,C17,NNN	
21	PAFZZ	5305012155174	19207	12340515	SCREW,ASSEMBLED WAS 4.2-1.41 X 13MM	1
					UCO:BVY,B15,B20,B24,B25,C17,NNN	
22	PAFZZ	5340008091500	96906	MS21333-107	CLAMP,LOOP.....	2
					UCO:BVY,B15,B20,B24,B25,C17,NNN	
23	PAFZZ	5340014148959	19207	12447103	BRACKET,ANGLE.....	1
					UCO:BVY,B15,B20,B24,B25,C17,NNN	
24	PAFZZ	5306012067172	7X677	11501940	BOLT,MACHINE 10-1.5 X 20MM.....	2

SECTION II			TM9-2320-280-24P			
(1)	(2)	(3)	(4)	(5)	(6)	(7)
ITEM	SMR			PART		
NO	CODE	NSN	CAGEC	NUMBER	DESCRIPTION AND USABLE ON CODES(UC)	QTY
25	PPFZZ	5340012134667	19207	12340663-1	UOC:BVY,B15,B20,B24,B25,C17,NNN STRAP,RETAINING.....	2
26	PAFZZ	5342012055381	19207	12340664	UOC:BVY,B15,B20,B24,B25,C17,NNN STRAP.....	2
27	PPFZZ	5340011980480	19207	12339343	UOC:BVY,B15,B20,B24,B25,C17,NNN BRACKET,MOUNTING.....	1
28	PAFZZ	5975005709598	96906	MS3367-7-9	UOC:BVY,B15,B20,B24,B25,C17,NNN STRAP,TIEDOWN,ELECT.....	3
					UOC:BVY,B15,B20,B24,B25,C17,NNN	

END OF FIGURE

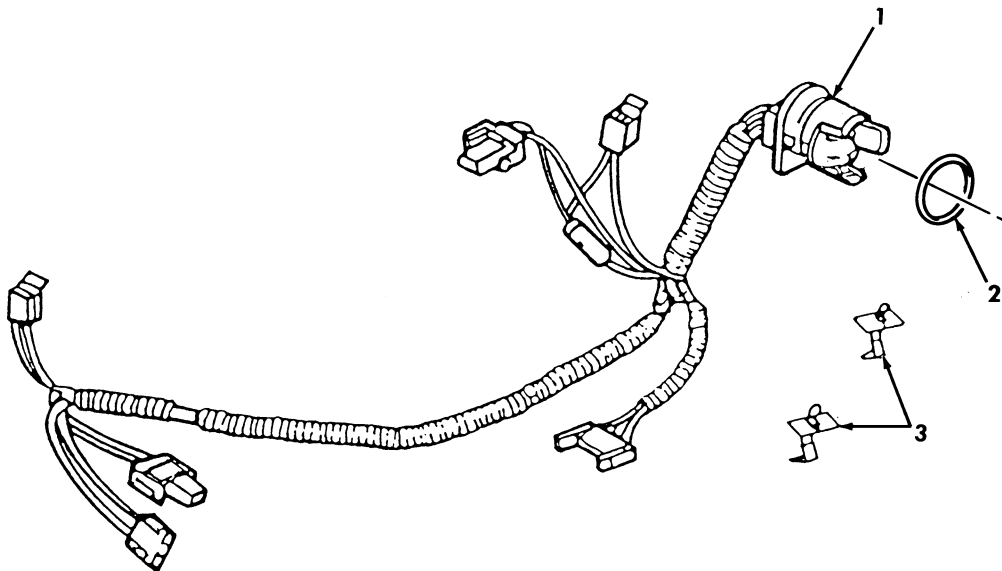

Figure 78. Transmission Wiring Harness.

SECTION II			TM9-2320-280-24P			
(1)	(2)	(3)	(4)	(5)	(6)	(7)
ITEM	SMR			PART		
NO	CODE	NSN	CAGEC	NUMBER	DESCRIPTION AND USABLE ON CODES(UOC)	QTY
					GROUP 0613 HULL OR CHASSIS WIRING HARNESS	
					FIG. 78 A2 TRANSMISSION WIRING HARNESS	
1	PAFZZ	6150014702011	7X677	12181863	WIRING HARNESS, BRAN 1997,98.....	1
					UOC:BVY,B15,B20,B24,B25,C17,NNN	
1	PAFZZ	6150014702009	7X677	12143072	WIRING HARNESS, BRAN 1995.....	1
					UOC:BVY,B15,B20,B24,B25,C17,NNN	
1	PAFZZ	6150014702016	7X677	12181688	WIRING HARNESS, BRAN 1996.....	1
					UOC:BVY,B15,B20,B24,B25,C17,NNN	
2	PAFZZ	5330010967699	7X677	10054241	SEAL, SPEEDOMETER.....	1
					UOC:BVY,B15,B20,B24,B25,C17,NNN	
3	PAFZZ	5340014475839	7X677	8675539	CLIP, SPRING TENSION.....	2
					UOC:BVY,B15,B20,B24,B25,C17,NNN	

END OF FIGURE



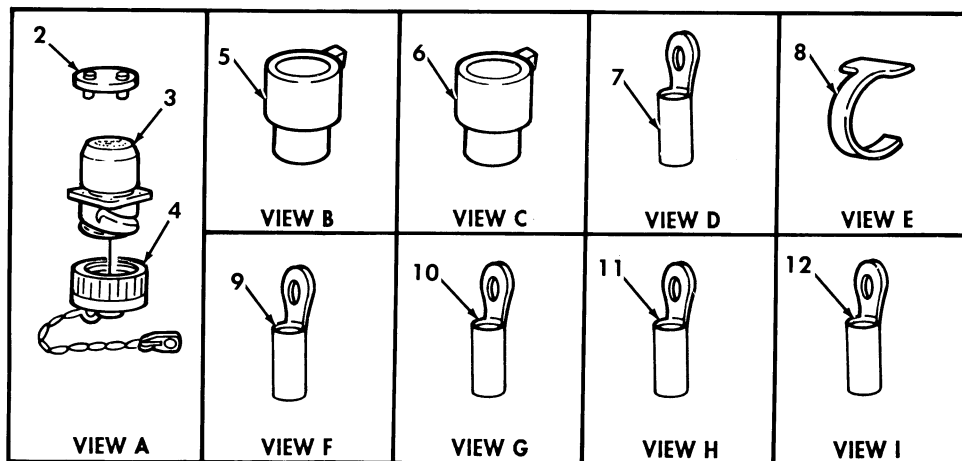
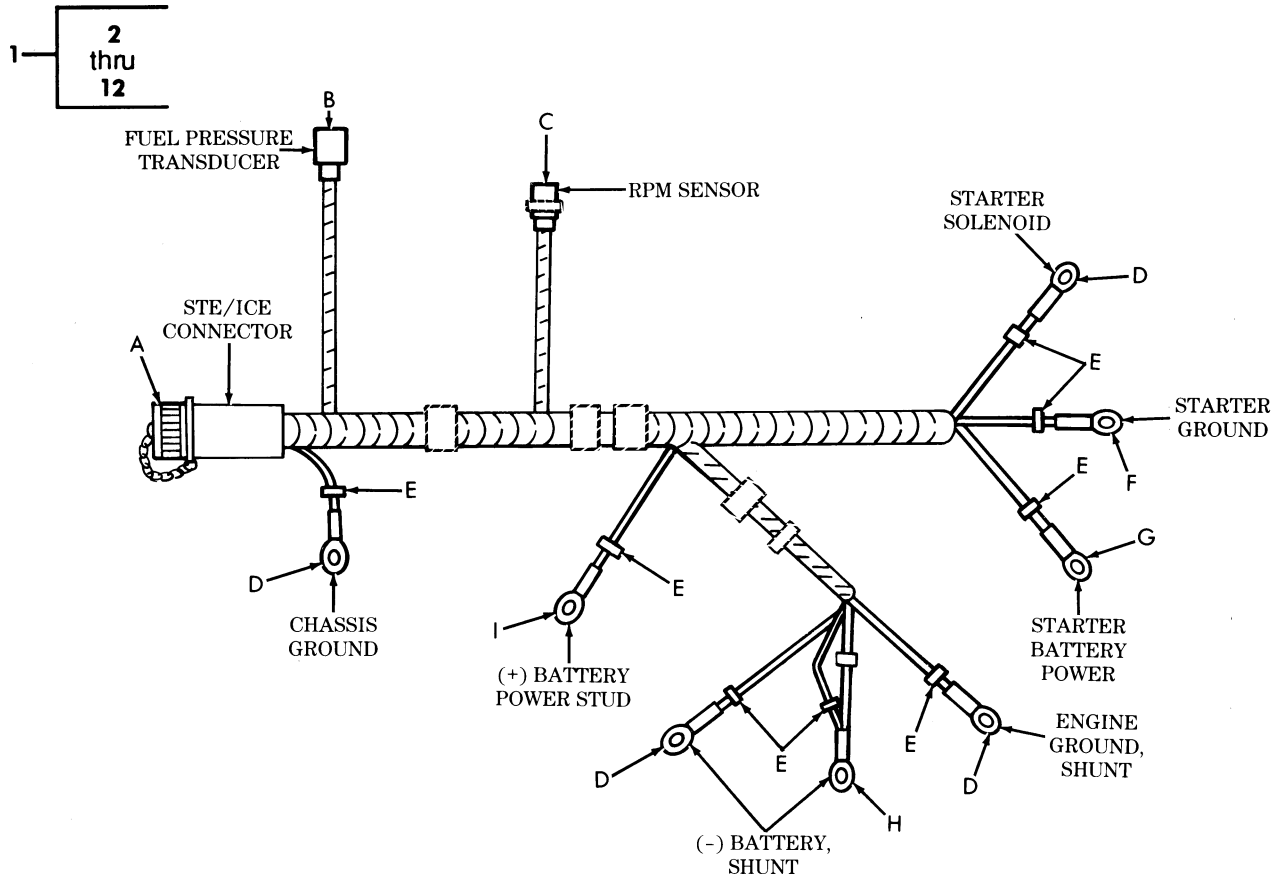

Figure 79. STE/ICE Wiring Harness (Sheet 1 of 2).

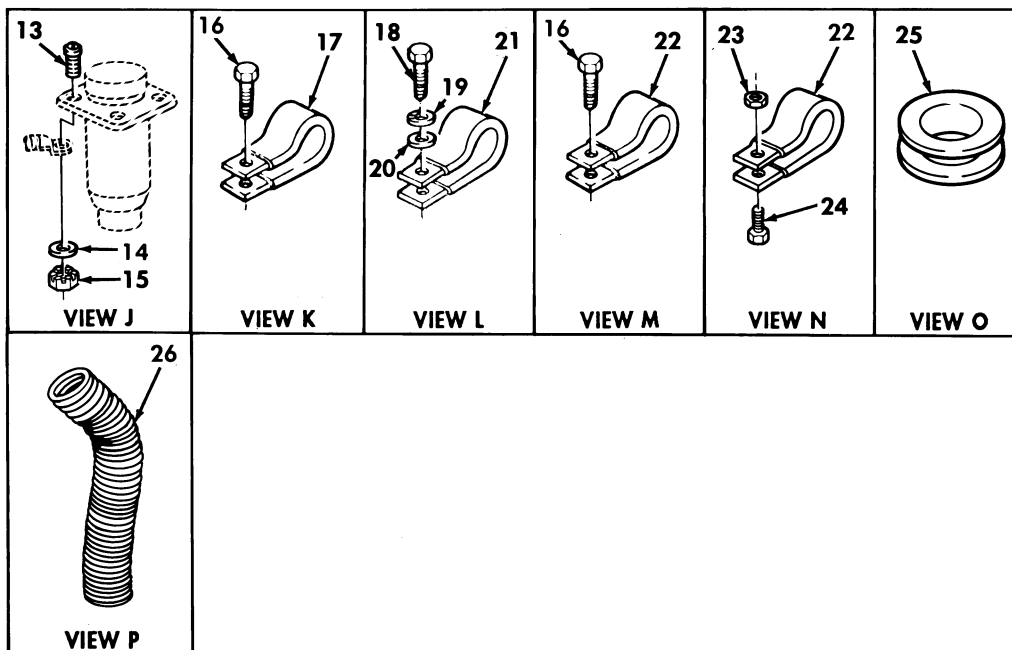
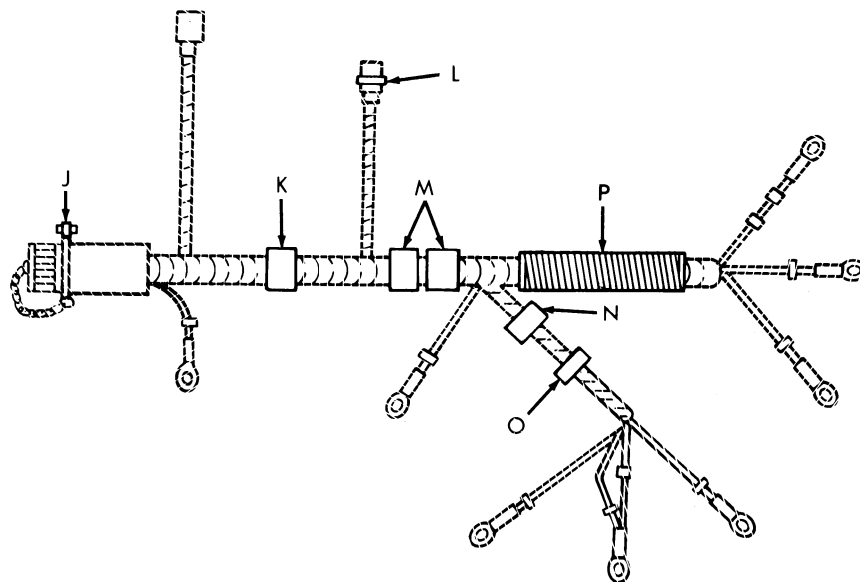

Figure 79. STE/ICE Wiring Harness (Sheet 2 of 2).

SECTION II			TM9-2320-280-24P			
(1)	(2)	(3)	(4)	(5)	(6)	(7)
ITEM	SMR			PART		
NO	CODE	NSN	CAGEC	NUMBER	DESCRIPTION AND USABLE ON CODES(UC)	QTY
					GROUP 0613 HULL OR CHASIS WIRING HARNESS	
					FIG. 79 STE/ICE WIRING HARNESS	
1	PAFFF	5995011842228	96139	5577626	WIRING HARNESS,BRAN STE/ICE.....	1
2	XAFZZ		34623	5578215	.PRINTED CIRCUIT BOA.....	1
3	PAFZA	5935012095594	34623	5578306-B	.CONNECTOR,RECEPTACL.....	1
4	PAFZZ	5340011580098	34623	5995301	.CAP,PROTECTIVE,DUST.....	1
5	PAFZZ	5935011546233	08718	SS4R-120-1806-00	.CONNECTOR,PLUG,ELEC.....	1
				0		
6	PAFZZ	5935011495165	08718	SS2R-120-1804-00	.CONNECTOR BODY,PLUG.....	1
				0		
7	PAOZZ	5940009834067	16528	7728777	.TERMINAL,LUG.....	4
8	PAOZZ	9905010138723	81349	M43436/3-1	.BAND,MARKER.....	8
9	PAOZZ	5940010354212	19207	7728780	.TERMINAL,LUG.....	1
10	PAOZZ	5940012144563	28891	101450-S02	.TERMINAL,LUG.....	1
11	PAOZZ	5940000507106	55026	1-112757	.TERMINAL,LUG.....	1
12	PAOZZ	5940000200072	96906	MS35436-16	.TERMINAL,LUG.....	1
13	PAOZZ	5305009844992	96906	MS35206-232	SCREW,MACHINE #6-32 X 3/4.....	4
14	PAOZZ	5310010626864	06032	2310-0422-001	WASHER,FLAT #6.....	4
15	PAOZZ	5310011867702	11862	134530	NUT,PLAIN,ASSEMBLED #6-32.....	4
16	PAFZZ	5305012596322	34623	12342499-1	SCREW,MACHINE #10-32 X 1/2.....	3
17	PAFZZ	5340000913790	96906	MS21333-72	CLAMP,LOOP.....	1
18	PAFZZ	5306012067172	7X677	11501940	BOLT,MACHINE.....	1
19	PAFZZ	5310006379541	96906	MS35338-46	WASHER,LOCK 3/8.....	1
20	PAFZZ	5310000806004	96906	MS27183-14	WASHER,FLAT.....	1
21	PAFZZ	5340008338476	96906	MS21333-122	CLAMP,LOOP.....	1
22	PAFZZ	5340000572904	96906	MS21333-71	CLAMP,LOOP.....	3
23	PAFZZ	5310001249265	72582	271169	NUT,PLAIN,ASSEMBLED #10-32.....	1
24	PAFZZ	5305009931848	96906	MS35207-265	SCREW,MACHINE #10-32 X 3/4.....	1
25	PAFZZ	5325002636651	59875	TD97203	GROMMET,NONMETALLIC.....	1
26	PAOZZ		19207	12339331	SHIELD,CABLE.....	1

END OF FIGURE

1 — 2 thru 10

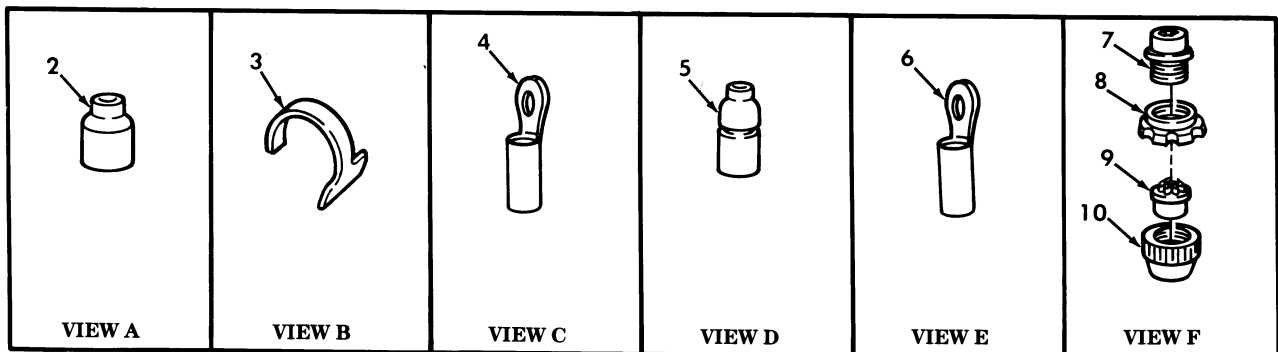
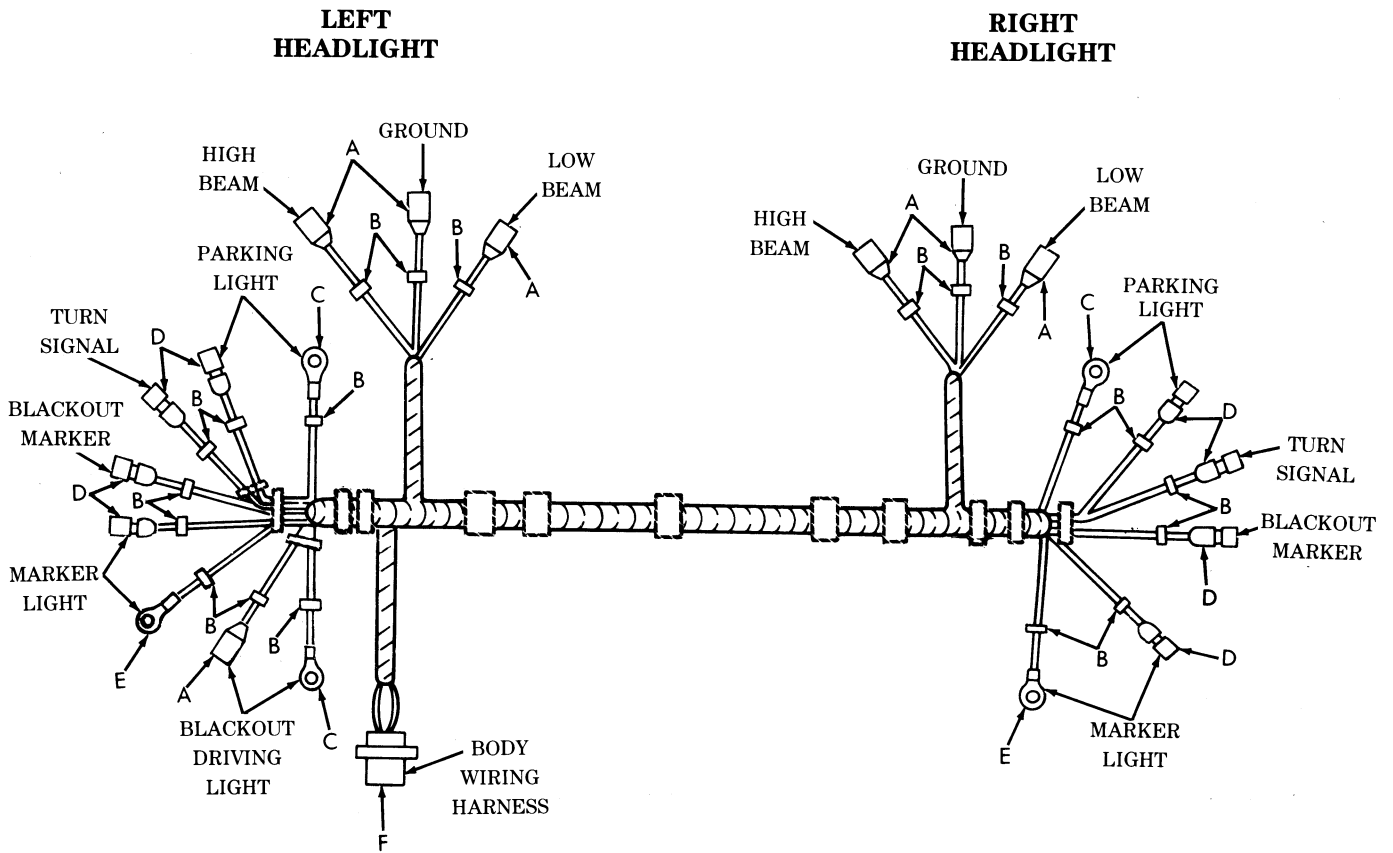

Figure 80. Hood Wiring Harness (Sheet 1 of 2).

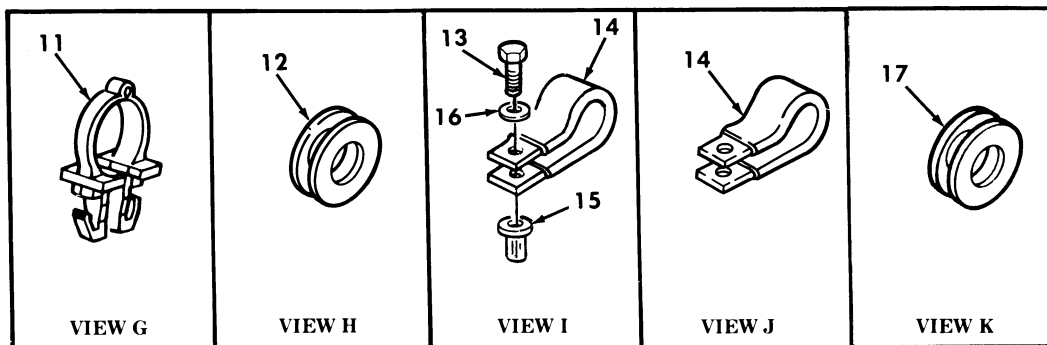
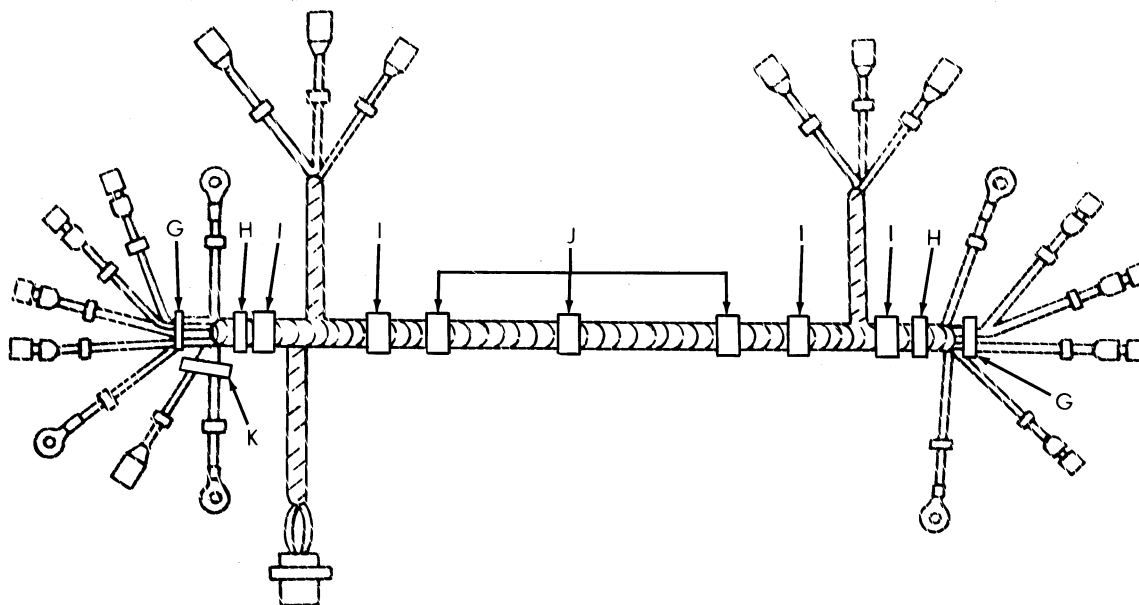

Figure 80. Hood Wiring Harness (Sheet 2 of 2).

SECTION II			TM9-2320-280-24P			
(1)	(2)	(3)	(4)	(5)	(6)	(7)
ITEM	SMR			PART		
NO	CODE	NSN	CAGEC	NUMBER	DESCRIPTION AND USABLE ON CODES(UC)	QTY
					GROUP 0613 HULL OR CHASSIS WIRING HARNESS	
					FIG. 80 HOOD WIRING HARNESS	
1	PFOFF	5995011845544	19207	12339349	WIRING HARNESS, BRAN.....	1
2	PAOZZ	5935004626603	96906	MS27142-2	.CONNECTOR, PLUG, ELEC.....	7
3	PAOZZ	9905010138723	81349	M43436/3-1	.BAND, MARKER.....	20
4	PAOZZ	5940007056711	56501	TG11	.TERMINAL, LUG.....	3
5	PAOZA	5935001677775	96906	MS27144-1	.CONNECTOR, PLUG, ELEC.....	8
6	PAOZZ	5940007056708	56501	TG8	.TERMINAL, LUG.....	2
7	PAFZZ	5935006143959	77820	10-42622-235	.CONNECTOR, PLUG, ELEC.....	1
8	PAFZZ	5310006559860	19207	8701325	.NUT, SLEEVE.....	1
9	PAFZZ	5365007722322	19207	7722322	.BUSHING, NONMETALLIC.....	1
10	PAFZZ	5935003339414	19207	7723308	.NUT, BUSHING RETAINE.....	1
11	PAOZZ	5325012147817	34623	5588705	FASTENER, SPRING TEN.....	2
12	PAOZZ	5325001749332	96906	MS35489-48	GROMMET, NONMETALLIC.....	2
13	PAOZZ	5305000712505	80204	B1821BH025C088N	SCREW, CAP, HEXAGON H 1/4-20 X 7/8...	4
14	PAOZZ	5340009881162	96906	MS21333-113	CLAMP, LOOP.....	7
15	PAOZZ	5340012134662	19207	12339397-4	SHIELD, EXPANSION 1/4-20.....	4
16	PAOZZ	5310008094058	42280	61-0542-1	WASHER, FLAT 3/8.....	4
17	PAOZZ	5325002024005	96906	MS35489-110	GROMMET, NONMETALLIC.....	1

END OF FIGURE

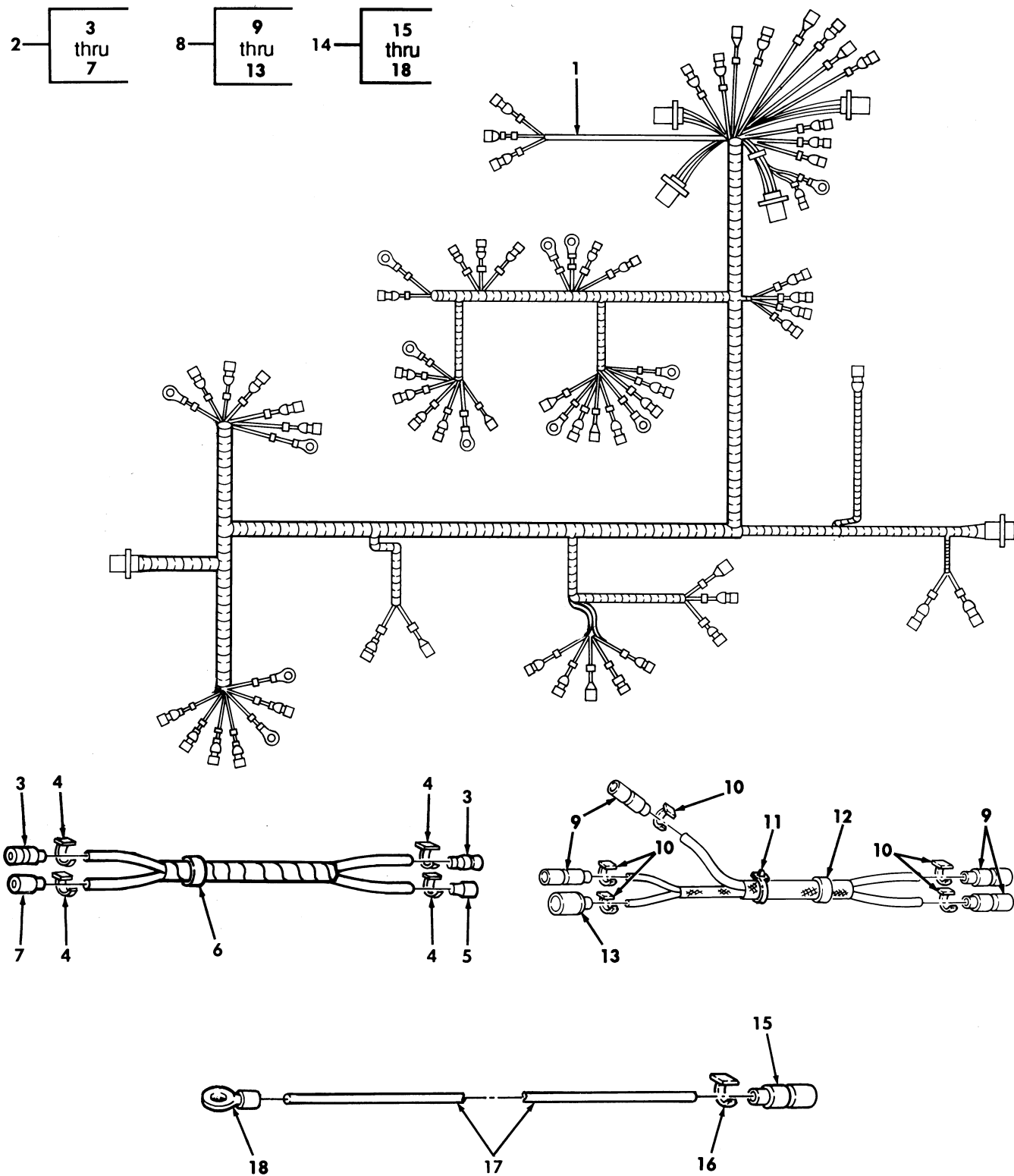

Figure 81. Body Wiring Harness and Fuel Tank Jumper Assembly (Sheet 1 of 2).

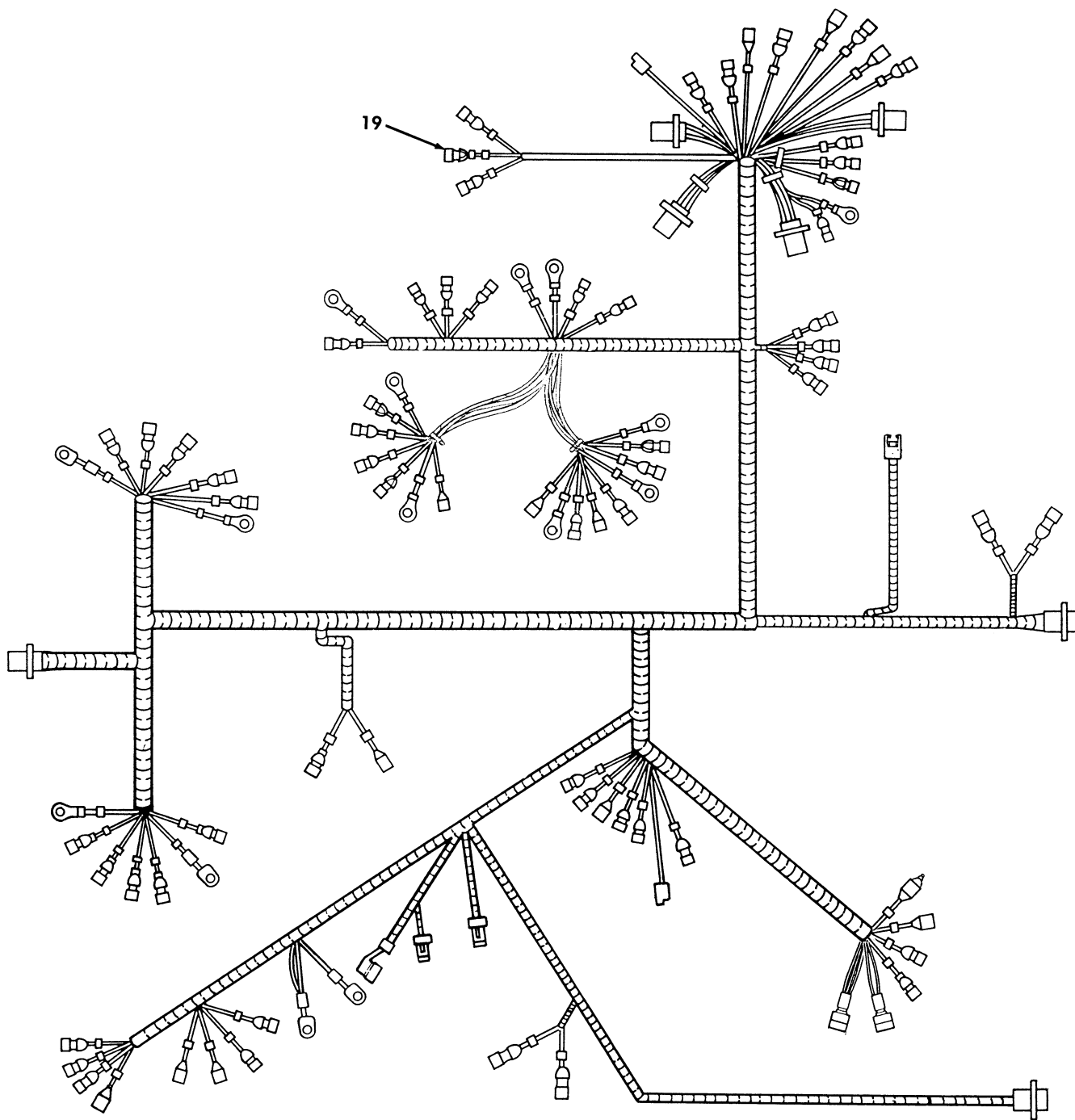

Figure 81. Body Wiring Harness and Fuel Tank Jumper Assembly (Sheet 2 of 2).



SECTION II			TM9-2320-280-24P			
(1)	(2)	(3)	(4)	(5)	(6)	(7)
ITEM NO	SMR CODE	NSN	CAGEC	PART NUMBER	DESCRIPTION AND USABLE ON CODES(UOC)	QTY
					GROUP 0613 HULL OR CHASSIS WIRING HARNESS	
					FIG. 81 BODY WIRING HARNESS AND FUEL TANK JUMPER ASSEMBLY	
1	PFFFF	5995011883269	19207	12339345	WIRING HARNESS, BRAN..... UOC:AVY,A11,A13,A14,A24,A25,A26,A27, B17,B18,HVY,H11,H13,H14,H17,H18,H21, H24,H25,H26,H27,H28,MMM	1
2	PFOOO	5995012103594	19207	12339342	CABLE ASSEMBLY, SPEC..... UOC:AVY,A11,A13,A14,A24,A25,A26,A27, B17,B18,HVY,H11,H13,H14,H17,H18,H21, H24,H25,H26,H27,H28,MMM	1
3	PAOZA	5935001677775	96906	MS27144-1	.CONNECTOR, PLUG, ELEC..... UOC:AVY,A11,A13,A14,A24,A25,A26,A27, B17,B18,HVY,H11,H13,H14,H17,H18,H21, H24,H25,H26,H27,H28,MMM	2
4	PAOZZ	9905010138723	81349	M43436/3-1	.BAND, MARKER..... UOC:AVY,A11,A13,A14,A24,A25,A26,A27, B17,B18,HVY,H11,H13,H14,H17,H18,H21, H24,H25,H26,H27,H28,MMM	4
5	PAOZA	5935001846707	96906	MS27144-3	.CONNECTOR, PLUG, ELEC..... UOC:AVY,A11,A13,A14,A24,A25,A26,A27, B17,B18,HVY,H11,H13,H14,H17,H18,H21, H24,H25,H26,H27,H28,MMM	1
6	PFOZZ	9905008933570	81349	M43436/1-3	.BAND, MARKER..... UOC:AVY,A11,A13,A14,A24,A25,A26,A27, B17,B18,HVY,H11,H13,H14,H17,H18,H21, H24,H25,H26,H27,H28,MMM	1
7	PAOZZ	5935004626603	96906	MS27142-2	.CONNECTOR, PLUG, ELEC..... UOC:AVY,A11,A13,A14,A24,A25,A26,A27, B17,B18,HVY,H11,H13,H14,H17,H18,H21, H24,H25,H26,H27,H28,MMM	1
8	PFOOO	6150013625229	19207	12342789	WIRING HARNESS USE WITH TRANSFER ASSEMBLY P/N 5937387..... UOC:AVY,A11,A13,A14,A24,A25,A26,A27, B17,B18,HVY,H11,H13,H14,H17,H18,H21, H24,H25,H26,H27,H28,MMM	1
9	PAOZA	5935001152307	96906	MS27144-2	.CONNECTOR, PLUG, ELEC..... UOC:AVY,A11,A13,A14,A24,A25,A26,A27, B17,B18,HVY,H11,H13,H14,H17,H18,H21, H24,H25,H26,H27,H28,MMM	4
10	PFOZZ	9905010138723	81349	M43436/3-1	.BAND, MARKER..... UOC:AVY,A11,A13,A14,A24,A25,A26,A27, B17,B18,HVY,H11,H13,H14,H17,H18,H21, H24,H25,H26,H27,H28,MMM	5
11	PAOZZ	5975009846582	96906	MS3367-1-0	.STRAP, TIEDOWN, ELECT..... UOC:AVY,A11,A13,A14,A24,A25,A26,A27, B17,B18,HVY,H11,H13,H14,H17,H18,H21, H24,H25,H26,H27,H28,MMM	4
12	PFOZZ	9905008933570	81349	M43436/1-3	.BAND, MARKER..... UOC:AVY,A11,A13,A14,A24,A25,A26,A27,	1

SECTION II			TM9-2320-280-24P			
(1)	(2)	(3)	(4)	(5)	(6)	(7)
ITEM NO	SMR CODE	NSN	CAGEC	PART NUMBER	DESCRIPTION AND USABLE ON CODES(UC)	QTY
13	PAOZZ	5935001152306	96906	MS27142-3	B17,B18,HVY,H11,H13,H14,H17,H18,H21, H24,H25,H26,H27,H28,MMM .CONNECTOR,PLUG,ELEC.....	1
					UC:AVY,A11,A13,A14,A24,A25,A26,A27, B17,B18,HVY,H11,H13,H14,H17,H18,H21, H24,H25,H26,H27,H28,MMM	
14	PFOOO	6150014732435	19207	12339324	LEAD,ELECTRICAL TALL LAMP GROUND...	2
					UC:A20,B20,H20	
14	PAOOO	2590012172662	19207	12339323	LEAD,WIRE,ELECTRICA BACKUP LAMP GROUND.....	2
					UC:A20,B20,H20	
15	PAOZA	5935001677775	96906	MS27144-1	.CONNECTOR,PLUG,ELEC.....	1
					UC:A20,B20,H20	
16	PAOZZ	9905010138723	81349	M43436/3-1	.BAND,MARKER.....	1
					UC:A20,B20,H20	
17	PAOZZ	6145001526499	81349	M13486/1-5	.WIRE,ELECTRICAL.....	1
					UC:A20,B20,H20	
18	PAOZZ	5940007056711	56501	TG11	.TERMINAL,LUG.....	1
					UC:A20,B20,H20	
19	PFFFF	6150014130853	19207	12460097	CABLE ASSEMBLY,POWE.....	1
					UC:BVY,B24,B25,C17,NNN	

END OF FIGURE

**USE WITH BASIC AND A1 VEHICLES**

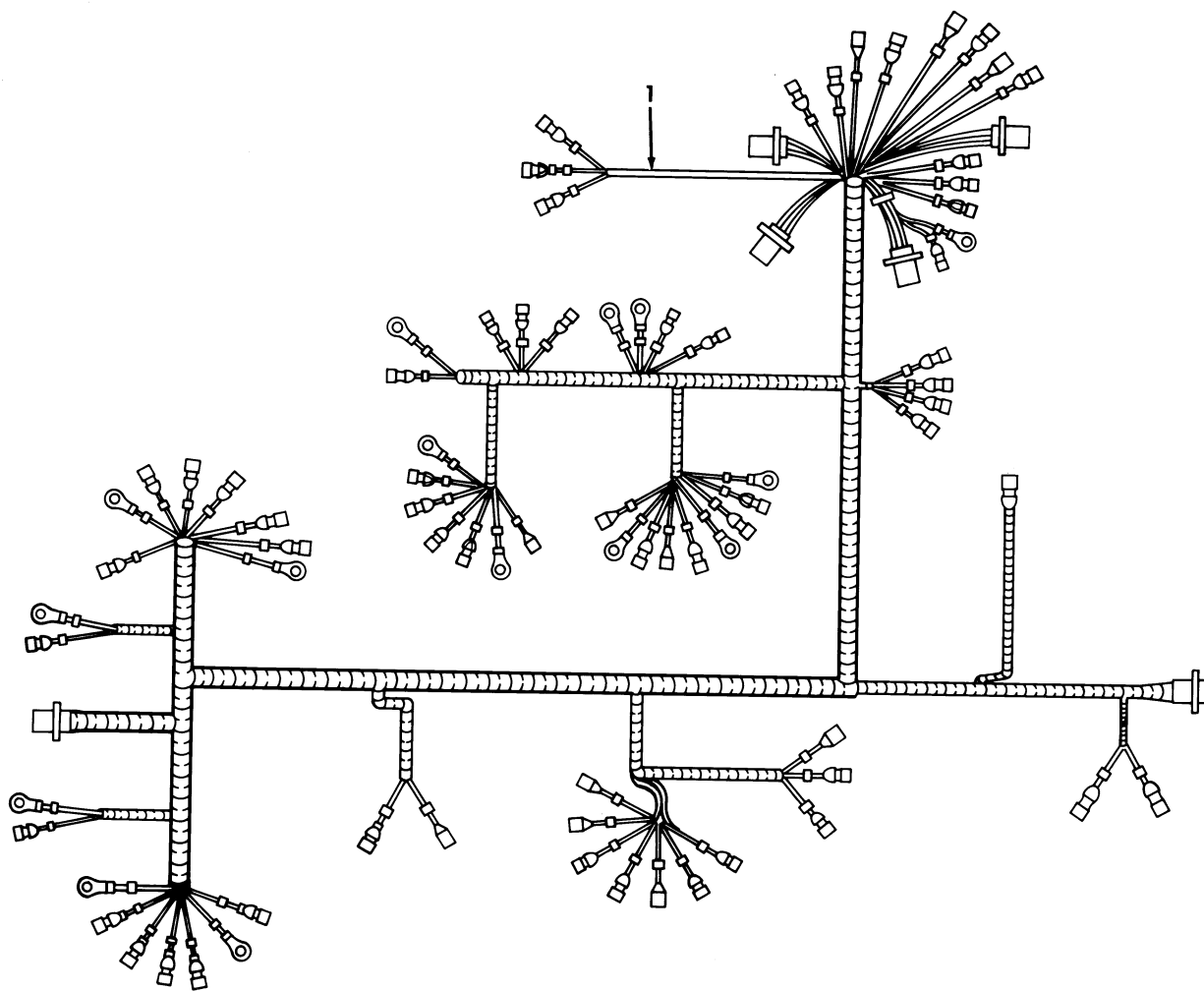

*Figure 82. Body Wiring Harness, Ambulance (Sheet 1 of 2).*

**USE WITH M997A2 VEHICLES ONLY**

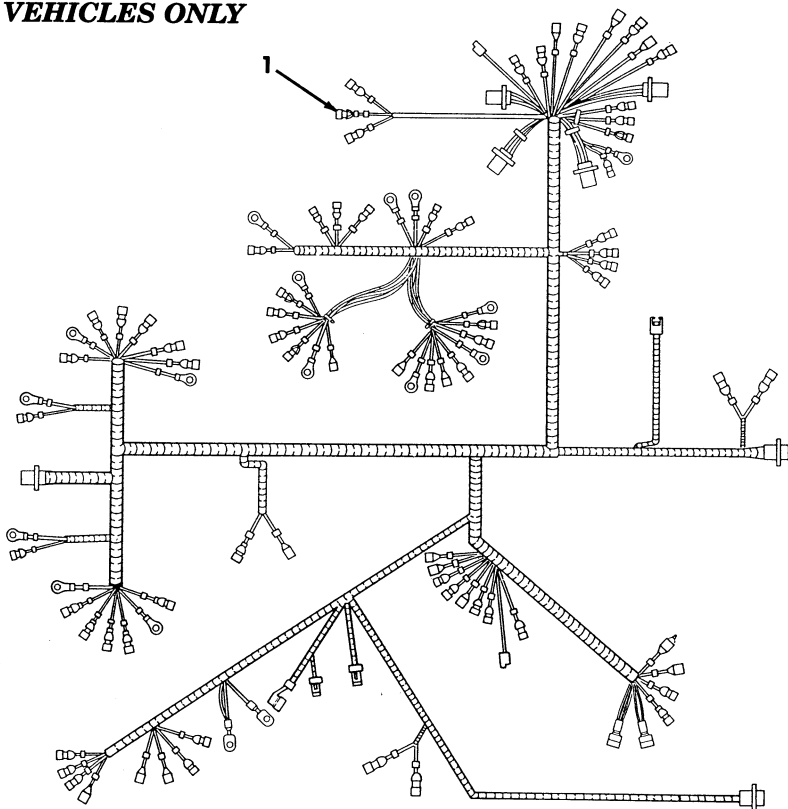

**USE WITH M1035A2 VEHICLES ONLY**

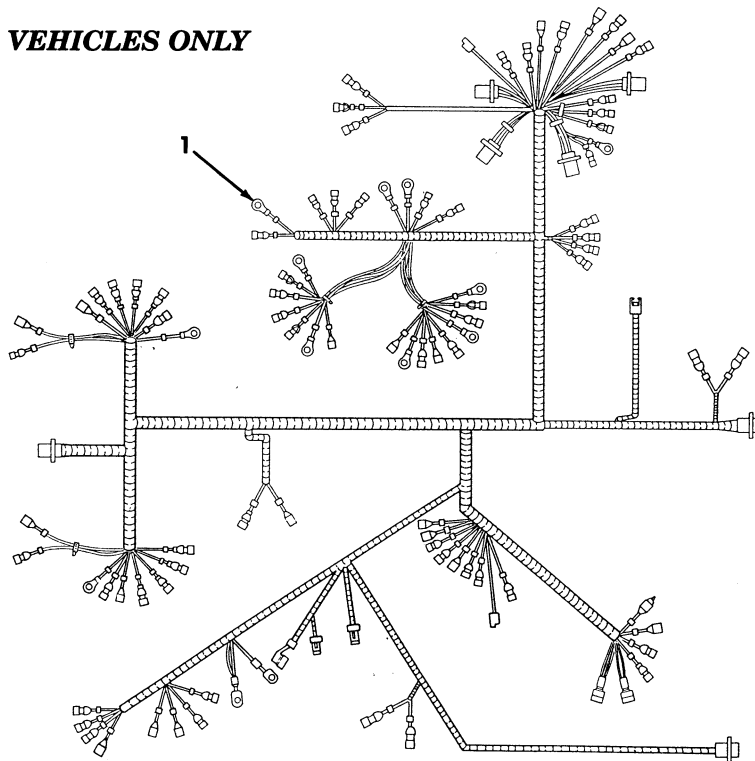

Figure 82. Body Wiring Harness, Ambulance (Sheet 2 of 2).

SECTION II			TM9-2320-280-24P			
(1)	(2)	(3)	(4)	(5)	(6)	(7)
ITEM	SMR			PART		
NO	CODE	NSN	CAGEC	NUMBER	DESCRIPTION AND USABLE ON CODES(UC)	QTY
					GROUP 0613 HULL OR CHASSIS WIRING HARNESS	
					FIG. 82 BODY WIRING HARNESS, AMBULANCE	
1	PFFFF	6150014131845	19207	12460099	CABLE ASSEMBLY,POWE.....	1
					UC:B20	
1	PFFFF	6150014131847	19207	12460098	CABLE ASSEMBLY,POWE.....	1
					UC:B15	
1	PFFFF	5995011975554	19207	12339346	WIRING HARNESS,BRAN.....	1
					UC:A20,H20	
1	PFFFF	5995013092953	19207	12340843	WIRING HARNESS,BRAN.....	1
					UC:A15,B16,H15,H16	

END OF FIGURE

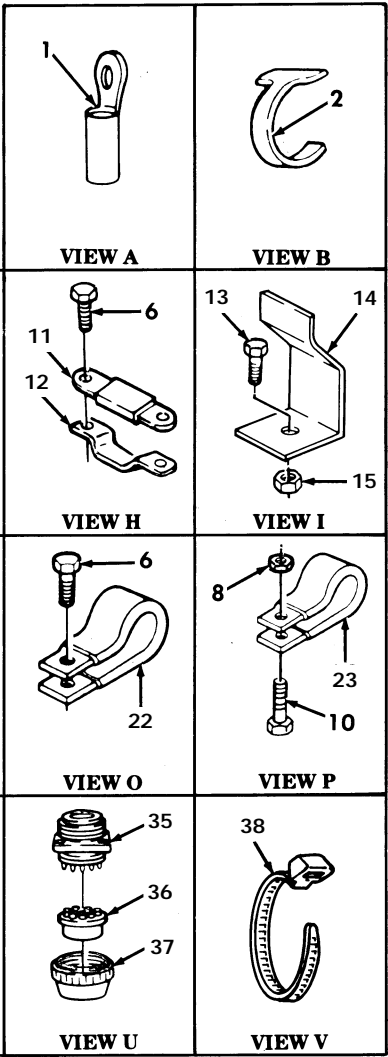
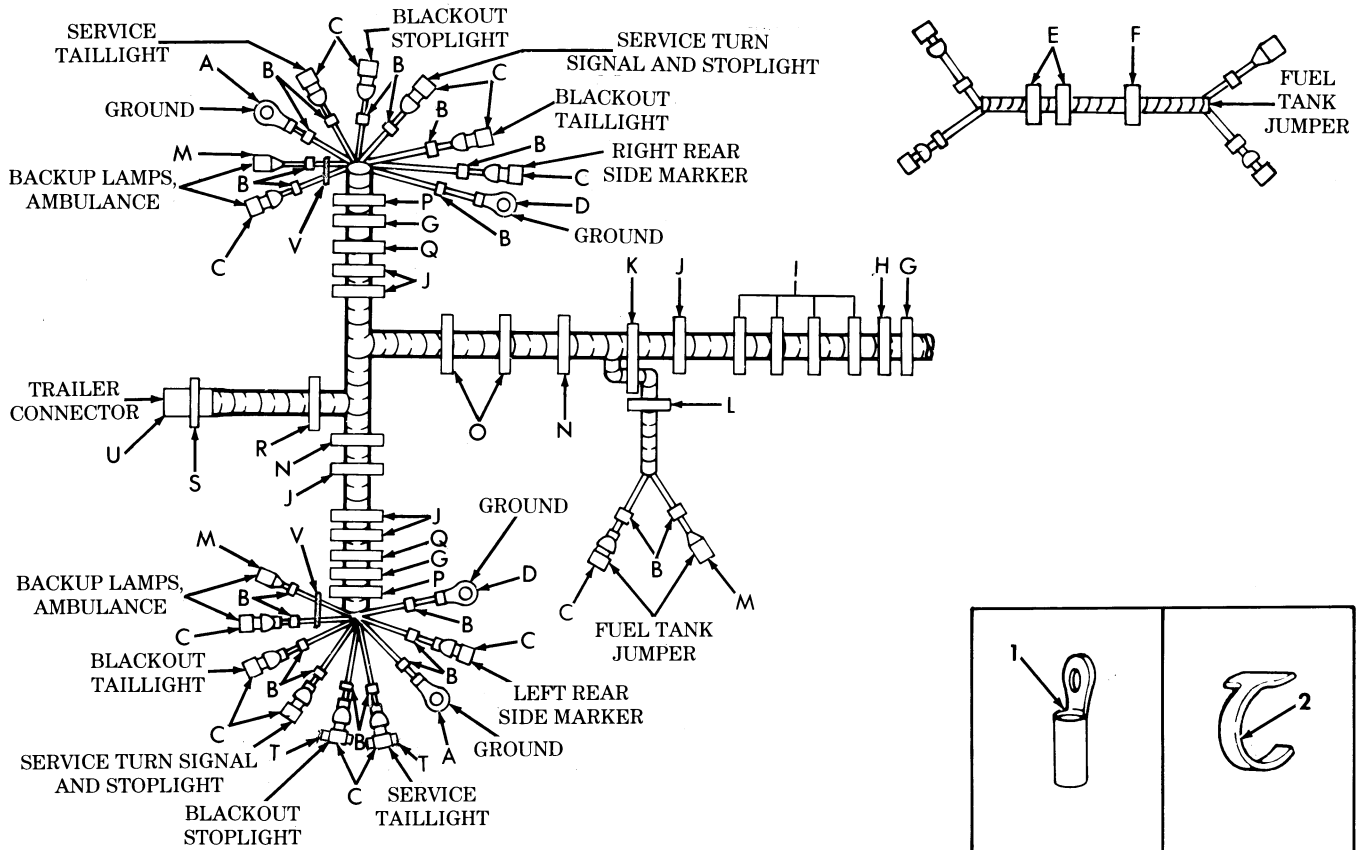

Figure 83. Body Wiring Harness - Partial View.

SECTION II			TM9-2320-280-24P			
(1)	(2)	(3)	(4)	(5)	(6)	(7)
ITEM NO	SMR CODE	NSN	CAGEC	PART NUMBER	DESCRIPTION AND USABLE ON CODES(UOC)	QTY
					GROUP 0613 HULL OR CHASSIS WIRING HARNESS	
					FIG. 83 BODY WIRING HARNESS-PARTIAL VIEW	
1	PAOZZ	5940007056711	56501	TG11	TERMINAL, LUG.....	2
					UOC:AVY, A11, A13, A14, A15, A20, A24, A25, A26, A27, B16, B17, B18, HVY, H11, H13, H14, H15, H16, H17, H18, H20, H21, H24, H25, H26, H27, H28, MMM	
2	PAFZZ	9905010138723	81349	M43436/3-1	BAND, MARKER.....	20
					UOC:AVY, A11, A13, A14, A15, A20, A24, A25, A26, A27, B16, B17, B18, HVY, H11, H13, H14, H15, H16, H17, H18, H20, H21, H24, H25, H26, H27, H28, MMM	
3	PAOZA	5935001677775	96906	MS27144-1	CONNECTOR, PLUG, ELEC.....	11
					UOC:AVY, A11, A13, A14, A15, A20, A24, A25, A26, A27, B16, B17, B18, HVY, H11, H13, H14, H15, H16, H17, H18, H20, H21, H24, H25, H26, H27, H28, MMM	
4	PAOZZ	5940007056708	56501	TG8	TERMINAL, LUG.....	2
					UOC:AVY, A11, A13, A14, A15, A20, A24, A25, A26, A27, B16, B17, B18, HVY, H11, H13, H14, H15, H16, H17, H18, H20, H21, H24, H25, H26, H27, H28, MMM	
5	PAFZZ	5340008091492	81348	CMDX2-3PT573036	CLAMP, LOOP.....	2
					UOC:AVY, A11, A13, A14, A15, A20, A24, A25, A26, A27, B16, B17, B18, HVY, H11, H13, H14, H15, H16, H17, H18, H20, H21, H24, H25, H26, H27, H28, MMM	
6	PAFZZ	5305012046502	78189	112-1008800-003	SCREW #10-32 X 1/2.....	14
					UOC:AVY, A11, A13, A14, A15, A20, A24, A25, A26, A27, B16, B17, B18, HVY, H11, H13, H14, H15, H16, H17, H18, H20, H21, H24, H25, H26, H27, H28, MMM	
7	PAFZZ	5340012143712	19207	12340020	CLIP, SPRING TENSION.....	1
					UOC:AVY, A11, A13, A14, A15, A20, A24, A25, A26, A27, B16, B17, B18, HVY, H11, H13, H14, H15, H16, H17, H18, H20, H21, H24, H25, H26, H27, H28, MMM	
8	PAFZZ	5310012510726	34623	5593053	NUT, SELF-LOCKING, HE #10-32.....	6
					UOC:AVY, A11, A13, A14, A15, A20, A24, A25, A26, A27, B16, B17, B18, HVY, H11, H13, H14, H15, H16, H17, H18, H20, H21, H24, H25, H26, H27, H28, MMM	
9	PAFZZ	5340009899222	96906	MS21333-74	CLAMP, LOOP.....	3
					UOC:AVY, A11, A13, A14, A15, A20, A24, A25, A26, A27, B16, B17, B18, HVY, H11, H13, H14, H15, H16, H17, H18, H20, H21, H24, H25, H26, H27, H28, MMM	
10	PAFZZ	5305005829501	82386	410-63	SCREW, CAP, HEXAGON H #10-32 X 1/2...	6
					UOC:AVY, A11, A13, A14, A15, A20, A24, A25,	

SECTION II			TM9-2320-280-24P			
(1)	(2)	(3)	(4)	(5)	(6)	(7)
ITEM NO	SMR CODE	NSN	CAGEC	PART NUMBER	DESCRIPTION AND USABLE ON CODES(UOC)	QTY
11	PAFZZ	5340014436908	19207	12340666	A26, A27, B16, B17, B18, HVY, H11, H13, H14, H15, H16, H17, H18, H20, H21, H24, H25, H26, H27, H28, MMM PLATE, MOUNTING.....	1
					UOC: AVY, A11, A13, A14, A15, A20, A24, A25, A26, A27, B16, B17, B18, HVY, H11, H13, H14, H15, H16, H17, H18, H20, H21, H24, H25, H26, H27, H28, MMM	
12	PAFZZ	5340012134665	19207	12340665	STRAP, RETAINING.....	1
					UOC: AVY, A11, A13, A14, A15, A20, A24, A25, A26, A27, B16, B17, B18, HVY, H11, H13, H14, H15, H16, H17, H18, H20, H21, H24, H25, H26, H27, H28, MMM	
13	PAFZZ	5305012153990	7X677	453349	SCREW, CAP, HEXAGON H 1/4-20 X 1/2...	4
					UOC: AVY, A11, A13, A14, A15, A20, A24, A25, A26, A27, B16, B17, B18, HVY, H11, H13, H14, H15, H16, H17, H18, H20, H21, H24, H25, H26, H27, H28, MMM	
14	PAFZZ	5340012122407	19207	12339339	STRAP, RETAINING.....	4
					UOC: AVY, A11, A13, A14, A15, A20, A24, A25, A26, A27, B16, B17, B18, HVY, H11, H13, H14, H15, H16, H17, H18, H20, H21, H24, H25, H26, H27, H28, MMM	
15	PAFZZ	5310011520598	24617	271172	NUT, SELF-LOCKING, AS 1/4-20.....	4
					UOC: AVY, A11, A13, A14, A15, A20, A24, A25, A26, A27, B16, B17, B18, HVY, H11, H13, H14, H15, H16, H17, H18, H20, H21, H24, H25, H26, H27, H28, MMM	
16	PAFZZ	5340000913790	96906	MS21333-72	CLAMP, LOOP.....	6
					UOC: AVY, A11, A13, A14, A15, A20, A24, A25, A26, A27, B16, B17, B18, HVY, H11, H13, H14, H15, H16, H17, H18, H20, H21, H24, H25, H26, H27, H28, MMM	
17	PAFZZ	5305012596322	34623	5593913	SCREW, MACHINE #10-32 X 3/4.....	1
					UOC: AVY, A11, A13, A14, A15, A20, A24, A25, A26, A27, B16, B17, B18, HVY, H11, H13, H14, H15, H16, H17, H18, H20, H21, H24, H25, H26, H27, H28, MMM	
18	PAFZZ	5340007247038	96906	MS21333-76	CLAMP, LOOP.....	1
					UOC: AVY, A11, A13, A14, A15, A20, A24, A25, A26, A27, B16, B17, B18, HVY, H11, H13, H14, H15, H16, H17, H18, H20, H21, H24, H25, H26, H27, H28, MMM	
19	PAFZZ	5340007647051	96906	MS21333-69	CLAMP, LOOP.....	1
					UOC: AVY, A11, A13, A14, A15, A20, A24, A25, A26, A27, B16, B17, B18, HVY, H11, H13, H14, H15, H16, H17, H18, H20, H21, H24, H25, H26, H27, H28, MMM	
20	PAOZZ	5935004626603	96906	MS27142-2	CONNECTOR, PLUG, ELEC.....	2
					UOC: A15, A20, B16, H15, H16, H20	
20	PAOZZ	5935004626603	96906	MS27142-2	CONNECTOR, PLUG, ELEC.....	1
					UOC: AVY, A11, A13, A14, A24, A25, A26, A27, B17, B18, HVY, H11, H13, H14, H17, H18, H21,	



SECTION II			TM9-2320-280-24P			
(1)	(2)	(3)	(4)	(5)	(6)	(7)
ITEM NO	SMR CODE	NSN	CAGEC	PART NUMBER	DESCRIPTION AND USABLE ON CODES(UC)	QTY
21	PAFZZ	5340000502740	96906	MS21333-75	H24, H25, H26, H27, H28, MMM CLAMP, LOOP.....	2
					UOC:AVY, A11, A13, A14, A15, A20, A24, A25, A26, A27, B16, B17, B18, HVY, H11, H13, H14, H15, H16, H17, H18, H20, H21, H24, H25, H26, H27, H28, MMM	
22	PAFZZ	5340000572904	96906	MS21333-71	CLAMP, LOOP 1/4-20 X .88.....	2
					UOC:AVY, A11, A13, A14, A15, A20, A24, A25, A26, A27, B16, B17, B18, HVY, H11, H13, H14, H15, H16, H17, H18, H20, H21, H24, H25, H26, H27, H28, MMM	
23	PAFZZ	5340001501658	17773	11176106-5	CLAMP, LOOP.....	2
					UOC:AVY, A11, A13, A14, A15, A20, A24, A25, A26, A27, B16, B17, B18, HVY, H11, H13, H14, H15, H16, H17, H18, H20, H21, H24, H25, H26, H27, H28, MMM	
24	PAOZZ	5310011191024	24617	2436162	WASHER, FLAT 5/16.....	2
					UOC:AVY, A11, A13, A14, A15, A20, A24, A25, A26, A27, B16, B17, B18, HVY, H11, H13, H14, H15, H16, H17, H18, H20, H21, H24, H25, H26, H27, H28, MMM	
25	PAOZZ	5310008140673	96906	MS51943-33	NUT, SELF-LOCKING, HE 5/16-18.....	2
					UOC:AVY, A11, A13, A14, A15, A20, A24, A25, A26, A27, B16, B17, B18, HVY, H11, H13, H14, H15, H16, H17, H18, H20, H21, H24, H25, H26, H27, H28, MMM	
26	PAOZZ	5340013144951	19207	12338696-1	BRACKET, ANGLE.....	1
					UOC:A11, A13, A14, A20, A24, A25, A26, A27, B16, B17, B18, HVY, H11, H13, H14, H15, H16, H17, H18, H20, H21, H24, H25, H26, H27, MMM	
27	PAOZZ	5935014214801	19207	12339332	PLATE, RETAINING, ELE.....	1
					UOC:AVY, A11, A13, A14, A15, A20, A24, A25, A26, A27, B16, B17, B18, HVY, H11, H13, H14, H15, H16, H17, H18, H20, H21, H24, H25, H26, H27, H28, MMM	
28	PAOZZ	5935007731428	19207	7731428	COVER, ELECTRICAL CO.....	1
					UOC:AVY, A11, A13, A14, A15, A20, A24, A25, A26, A27, B16, B17, B18, HVY, H11, H13, H14, H15, H16, H17, H18, H20, H21, H24, H25, H26, H27, H28, MMM	
29	PAOZZ	5305003900524	96906	MS51849-98	SCREW, MACHINE 1/4-20 X 1.00.....	4
					UOC:A11, A13, A14, A20, A24, A25, A26, A27, B17, B18, H11, H13, H14, H17, H18, H20, H24, H25, H26, H27, MMM	
29	PAOZZ	5305009881725	96906	MS35206-281	SCREW, MACHINE.....	6
					UOC:AVY, A15, B16, HVY, H15, H16, H21, H28	
30	PAOZZ	5306002264827	80204	B1821BH031C100N	BOLT, MACHINE 5/16-18 X 1.00.....	2
					UOC:AVY, A11, A13, A14, A15, A20, A24, A25, A26, A27, B16, B17, B18, HVY, H11, H13, H14, H15, H16, H17, H18, H20, H21, H24, H25, H26, H27, H28, MMM	
31	PAOZZ	5310011520598	24617	271172	NUT, SELF-LOCKING, AS 1/4-20 X 1.00..	4
					UOC:AVY, A11, A15, B16, HVY, H15, H16, H21,	

SECTION II			TM9-2320-280-24P			
(1)	(2)	(3)	(4)	(5)	(6)	(7)
ITEM NO	SMR CODE	NSN	CAGEC	PART NUMBER	DESCRIPTION AND USABLE ON CODES(UC)	QTY
31	PAOZZ	5310011520598	24617	271172	H28 NUT, SELF-LOCKING, AS.....	6
					UOC:AVY, A11, A13, A14, A20, A24, A25, A26, A27, B17, B18, H11, H13, H14, H17, H18, H20, H24, H25, H26, H27, MMM	
32	PAOZZ	6220012573878	19207	12339008	GUARD, LAMP.....	2
					UOC:AVY, A11, A13, A14, A15, A20, A24, A25, A26, A27, B16, B17, B18, HVY, H11, H13, H14, H15, H16, H17, H18, H20, H21, H24, H25, H26, H27, H28, MMM	
33	PAOZZ	5310006379541	96906	MS35338-46	WASHER, LOCK 1/4.....	4
					UOC:AVY, A11, A13, A14, A15, A20, A24, A25, A26, A27, B16, B17, B18, HVY, H11, H13, H14, H15, H16, H17, H18, H20, H21, H24, H25, H26, H27, H28, MMM	
34	PAOZZ	5306002072221	23862	2136455	BOLT, MACHINE 1/4-20 X 3/4.....	4
					UOC:AVY, A11, A13, A14, A15, A20, A24, A25, A26, A27, B16, B17, B18, HVY, H11, H13, H14, H15, H16, H17, H18, H20, H21, H24, H25, H26, H27, H28, MMM	
35	PAFZA	5935008463884	96906	MS75021-2	CONNECTOR, RECEPTACL.....	1
					UOC:AVY, A11, A13, A14, A15, A20, A24, A25, A26, A27, B16, B17, B18, HVY, H11, H13, H14, H15, H16, H17, H18, H20, H21, H24, H25, H26, H27, H28, MMM	
36	PAFZZ	5365000905426	19207	7722333	BUSHING, NONMETALLIC.....	1
					UOC:AVY, A11, A13, A14, A15, A20, A24, A25, A26, A27, B16, B17, B18, HVY, H11, H13, H14, H15, H16, H17, H18, H20, H21, H24, H25, H26, H27, H28, MMM	
37	PAFZZ	5310003936685	19207	7723309	NUT, PLAIN, KNURLED.....	1
					UOC:AVY, A11, A13, A14, A15, A20, A24, A25, A26, A27, B16, B17, B18, HVY, H11, H13, H14, H15, H16, H17, H18, H20, H21, H24, H25, H26, H27, H28, MMM	
38	PAOZZ	5975009856630	96906	MS3367-3-0	STRAP, TIEDOWN, ELECT.....	2
					UOC:AVY, A11, A13, A14, A15, A20, A24, A25, A26, A27, B16, B17, B18, HVY, H11, H13, H14, H15, H16, H17, H18, H20, H21, H24, H25, H26, H27, H28, MMM	

END OF FIGURE

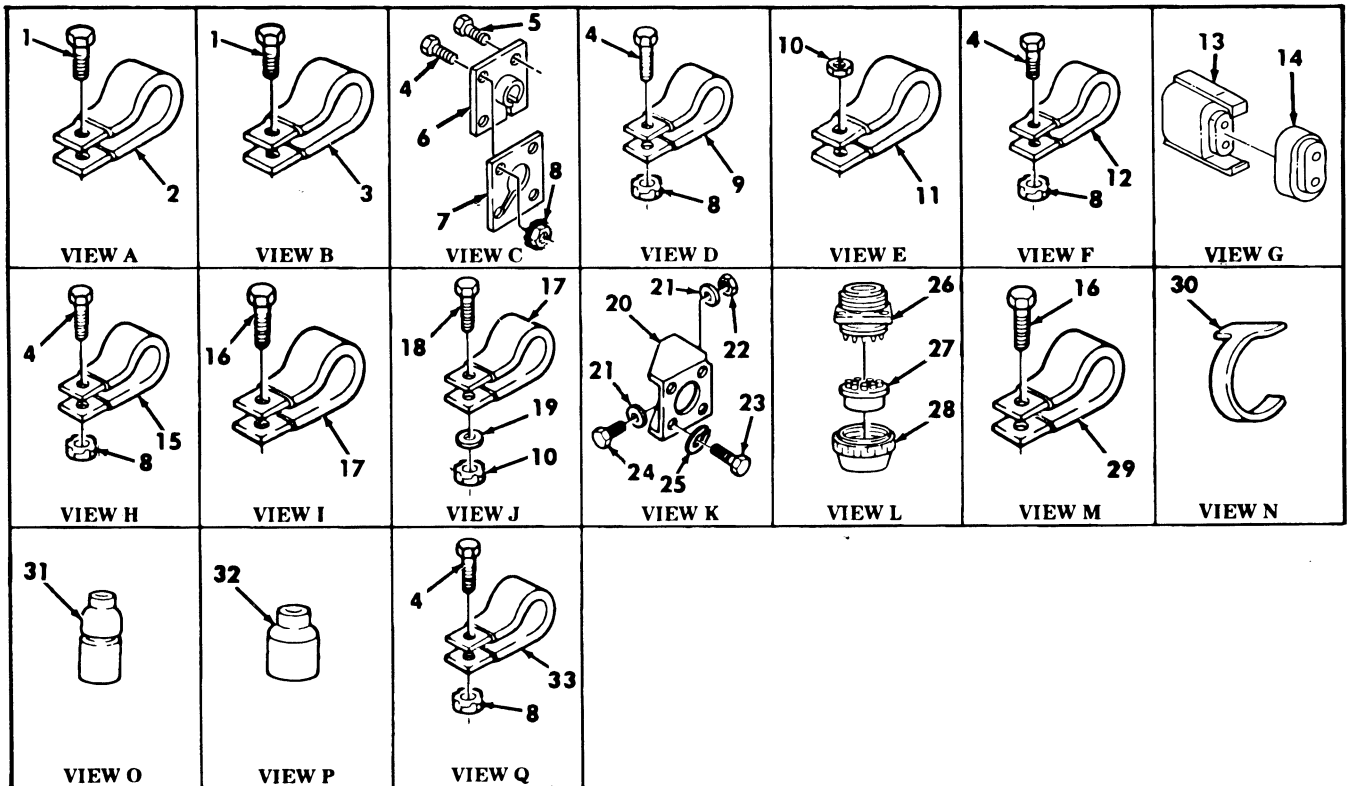
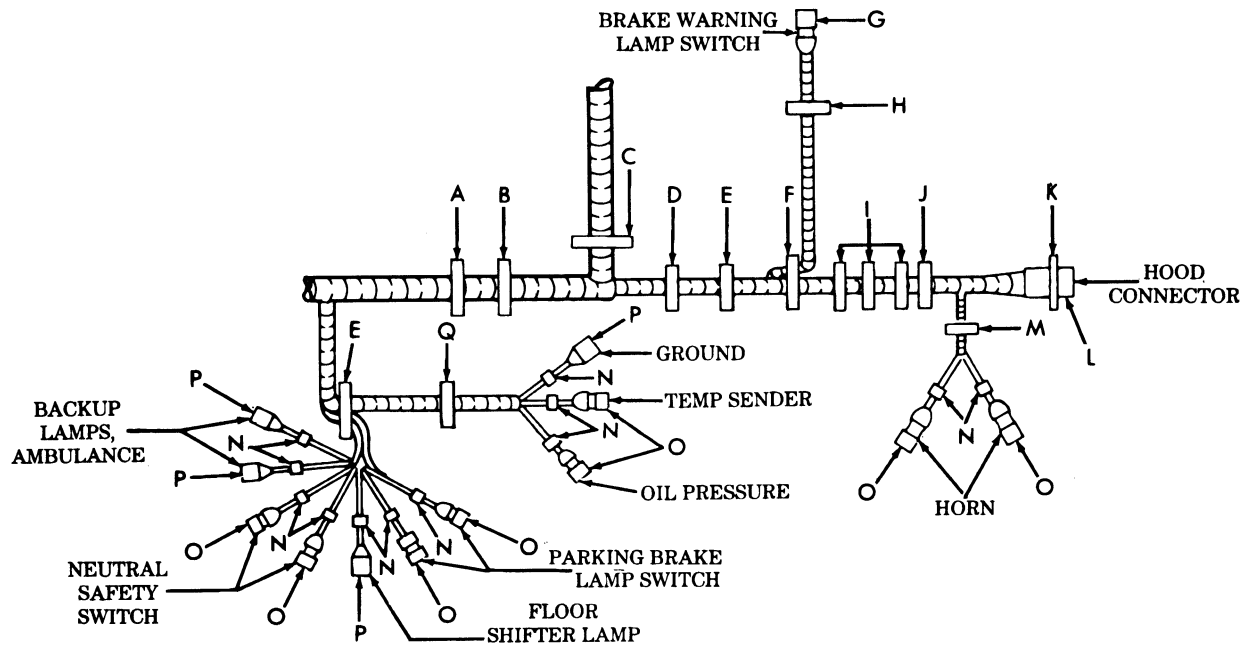

Figure 84. Body Wiring Harness - Partial View.

SECTION II			TM9-2320-280-24P			
(1)	(2)	(3)	(4)	(5)	(6)	(7)
ITEM NO	SMR CODE	NSN	CAGEC	PART NUMBER	DESCRIPTION AND USABLE ON CODES(UC)	QTY
					GROUP 0613 HULL OR CHASSIS WIRING HARNESS	
					FIG. 84 BODY WIRING HARNESS-PARTIAL VIEW	
1	PAFZZ	5305012046502	34623	5588064	SCREW #10-32 X 1/2.....	2
					UOC:AVY,A11,A13,A14,A15,A20,A24,A25,A26,A27,B16,B17,B18,HVY,H11,H13,H14,H15,H16,H17,H18,H20,H21,H24,H25,H26,H27,H28,MMM	
2	PAFZZ	5340009226300	96906	MS21333-77	CLAMP,LOOP.....	2
					UOC:AVY,A11,A13,A14,A15,A20,A24,A25,A26,A27,B16,B17,B18,HVY,H11,H13,H14,H15,H16,H17,H18,H20,H21,H24,H25,H26,H27,H28,MMM	
3	PAFZZ	5340007247038	96906	MS21333-76	CLAMP,LOOP.....	1
					UOC:AVY,A11,A13,A14,A15,A20,A24,A25,A26,A27,B16,B17,B18,HVY,H11,H13,H14,H15,H16,H17,H18,H20,H21,H24,H25,H26,H27,H28,MMM	
4	PAFZZ	5305005829501	82386	410-63	SCREW,CAP,HEXAGON H #10-32 X 1/2...	7
					UOC:AVY,A11,A13,A14,A15,A20,A24,A25,A26,A27,B16,B17,B18,HVY,H11,H13,H14,H15,H16,H17,H18,H20,H21,H24,H25,H26,H27,H28,MMM	
5	PAFZZ	5306000425570	24617	425570	BOLT,ASSEMBLED WASH #10-32 X 3/4...	1
					UOC:AVY,A11,A13,A14,A15,A20,A24,A25,A26,A27,B16,B17,B18,HVY,H11,H13,H14,H15,H16,H17,H18,H20,H21,H24,H25,H26,H27,H28,MMM	
6	PAFZZ	5325012101633	34623	5584391	GROMMET,NONMETALLIC.....	1
					UOC:AVY,A11,A13,A14,A15,A20,A24,A25,A26,A27,B16,B17,B18,HVY,H11,H13,H14,H15,H16,H17,H18,H20,H21,H24,H25,H26,H27,H28,MMM	
7	PAFZZ	5935012129631	19207	12339338	PLATE,RETAINING,ELE.....	1
					UOC:AVY,A11,A13,A14,A15,A20,A24,A25,A26,A27,B16,B17,B18,HVY,H11,H13,H14,H15,H16,H17,H18,H20,H21,H24,H25,H26,H27,H28,MMM	
8	PAFZZ	5310001249265	24617	271169	NUT,PLAIN,ASSEMBLED #10-32.....	8
					UOC:AVY,A11,A13,A14,A15,A20,A24,A25,A26,A27,B16,B17,B18,HVY,H11,H13,H14,H15,H16,H17,H18,H20,H21,H24,H25,H26,H27,H28,MMM	
9	PAFZZ	5340009899222	96906	MS21333-74	CLAMP,LOOP.....	1
					UOC:AVY,A11,A13,A14,A15,A20,A24,A25,A26,A27,B16,B17,B18,HVY,H11,H13,H14,H15,H16,H17,H18,H20,H21,H24,H25,H26,H27,H28,MMM	
10	PAFZZ	5310012522999	34623	5593033	NUT,SELF-LOCKING,AS 1/4-20.....	3
					UOC:AVY,A11,A13,A14,A15,A20,A24,A25,	

SECTION II			TM9-2320-280-24P			
(1)	(2)	(3)	(4)	(5)	(6)	(7)
ITEM	SMR			PART		
NO	CODE	NSN	CAGEC	NUMBER	DESCRIPTION AND USABLE ON CODES(UOC)	QTY
11	PAFZZ	5340008091494	96906	MS21333-105	A26,A27,B16,B17,B18,HVY,H11,H13,H14, H15,H16,H17,H18,H20,H21,H24,H25,H26, H27,H28,MMM CLAMP,LOOP.....	2
					UOC:AVY,A11,A13,A14,A15,A20,A24,A25, A26,A27,B16,B17,B18,HVY,H11,H13,H14, H15,H16,H17,H18,H20,H21,H24,H25,H26, H27,H28,MMM	
12	PAFZZ	5340000502740	96906	MS21333-75	CLAMP,LOOP.....	1
					UOC:AVY,A11,A13,A14,A15,A20,A24,A25, A26,A27,B16,B17,B18,HVY,H11,H13,H14, H15,H16,H17,H18,H20,H21,H24,H25,H26, H27,H28,MMM	
13	PAFZZ	5935012380543	19207	12340362	CONNECTOR, PLUG, ELEC.....	1
					UOC:AVY,A11,A13,A14,A15,A20,A24,A25, A26,A27,B16,B17,B18,HVY,H11,H13,H14, H15,H16,H17,H18,H20,H21,H24,H25,H26, H27,H28,MMM	
14	PAFZZ		19207	12339345-1	CONNECTOR, RECEPTACL.....	1
					UOC:AVY,A11,A13,A14,A15,A20,A24,A25, A26,A27,B16,B17,B18,HVY,H11,H13,H14, H15,H16,H17,H18,H20,H21,H24,H25,H26, H27,H28,MMM	
15	PAFZZ	5340002827509	96906	MS21333-62	CLAMP,LOOP.....	1
					UOC:AVY,A11,A13,A14,A15,A20,A24,A25, A26,A27,B16,B17,B18,HVY,H11,H13,H14, H15,H16,H17,H18,H20,H21,H24,H25,H26, H27,H28,MMM	
16	PAFZZ	5305012068401	34623	5592954	SCREW, TAPPING 1/4-28 X 1/2.....	3
					UOC:AVY,A11,A13,A14,A15,A20,A24,A25, A26,A27,B16,B17,B18,HVY,H11,H13,H14, H15,H16,H17,H18,H20,H21,H24,H25,H26, H27,H28,MMM	
17	PAFZZ	5340000881254	96906	MS21333-104	CLAMP, LOOP.....	4
					UOC:AVY,A11,A13,A14,A15,A20,A24,A25, A26,A27,B16,B17,B18,HVY,H11,H13,H14, H15,H16,H17,H18,H20,H21,H24,H25,H26, H27,H28,MMM	
18	PAFZZ	5305009881725	96906	MS35206-281	SCREW, MACHINE 1/4-20 X 3/4.....	1
					UOC:AVY,A11,A13,A14,A15,A20,A24,A25, A26,A27,B16,B17,B18,HVY,H11,H13,H14, H15,H16,H17,H18,H20,H21,H24,H25,H26, H27,H28,MMM	
19	PAFZZ	5310008094058	96906	MS27183-10	WASHER, FLAT.....	1
					UOC:AVY,A11,A13,A14,A15,A20,A24,A25, A26,A27,B16,B17,B18,HVY,H11,H13,H14, H15,H16,H17,H18,H20,H21,H24,H25,H26, H27,H28,MMM	
20	PAOZZ	5340012510754	19207	12338633	BRACKET, DOUBLE ANGL.....	1
					UOC:AVY,A11,A13,A14,A15,A20,A24,A25, A26,A27,B16,B17,B18,HVY,H11,H13,H14, H15,H16,H17,H18,H20,H21,H24,H25,H26, H27,H28,MMM	

SECTION II			TM9-2320-280-24P			
(1)	(2)	(3)	(4)	(5)	(6)	(7)
ITEM NO	SMR CODE	NSN	CAGEC	PART NUMBER	DESCRIPTION AND USABLE ON CODES(UC)	QTY
21	PAOZZ	5310008094058	96906	MS27183-10	WASHER, FLAT 1/4..... UC:AVY, A11, A13, A14, A15, A20, A24, A25, A26, A27, B16, B17, B18, HVY, H11, H13, H14, H15, H16, H17, H18, H20, H21, H24, H25, H26, H27, H28, MMM	4
22	PAOZZ	5310000614650	96906	MS51943-31	NUT, SELF-LOCKING, HE 1/4-20..... UC:AVY, A11, A13, A14, A15, A20, A24, A25, A26, A27, B16, B17, B18, HVY, H11, H13, H14, H15, H16, H17, H18, H20, H21, H24, H25, H26, H27, H28, MMM	2
23	PAOZZ	5305009846193	96906	MS35206-245	SCREW, MACHINE #6-32 X 1/2..... UC:AVY, A11, A13, A14, A15, A20, A24, A25, A26, A27, B16, B17, B18, HVY, H11, H13, H14, H15, H16, H17, H18, H20, H21, H24, H25, H26, H27, H28, MMM	4
24	PAOZZ	5305000680502	96906	MS90725-6	SCREW, CAP, HEXAGON H 1/4-20 X 3/4... UC:AVY, A11, A13, A14, A15, A20, A24, A25, A26, A27, B16, B17, B18, HVY, H11, H13, H14, H15, H16, H17, H18, H20, H21, H24, H25, H26, H27, H28, MMM	2
25	PAOZZ	5310000454007	96906	MS35338-41	WASHER, LOCK..... UC:AVY, A11, A13, A14, A15, A20, A24, A25, A26, A27, B16, B17, B18, HVY, H11, H13, H14, H15, H16, H17, H18, H20, H21, H24, H25, H26, H27, H28, MMM	4
26	PAOZZ	5935007722353	19207	7722353	CONNECTOR, RECEPTACL..... UC:AVY, A11, A13, A14, A15, A20, A24, A25, A26, A27, B16, B17, B18, HVY, H11, H13, H14, H15, H16, H17, H18, H20, H21, H24, H25, H26, H27, H28, MMM	1
27	PAFZZ	5365007722322	19207	7722322	BUSHING, NONMETALLIC..... UC:AVY, A11, A13, A14, A15, A20, A24, A25, A26, A27, B16, B17, B18, HVY, H11, H13, H14, H15, H16, H17, H18, H20, H21, H24, H25, H26, H27, H28, MMM	1
28	PAFZZ	5935003339414	19207	7723308	NUT, BUSHING RETAINE 1.25 X 18..... UC:AVY, A11, A13, A14, A15, A20, A24, A25, A26, A27, B16, B17, B18, HVY, H11, H13, H14, H15, H16, H17, H18, H20, H21, H24, H25, H26, H27, H28, MMM	1
29	PAFZZ	5340008091492	81348	CMDX2-3PT573036	CLAMP, LOOP..... UC:AVY, A11, A13, A14, A15, A20, A24, A25, A26, A27, B16, B17, B18, HVY, H11, H13, H14, H15, H16, H17, H18, H20, H21, H24, H25, H26, H27, H28, MMM	1
30	PAOZZ	9905010138723	81349	M43436/3-1	BAND, MARKER..... UC:AVY, A11, A13, A14, A15, A20, A24, A25, A26, A27, B16, B17, B18, HVY, H11, H13, H14, H15, H16, H17, H18, H20, H21, H24, H25, H26, H27, H28, MMM	12
31	PAOZA	5935001677775	96906	MS27144-1	CONNECTOR, PLUG, ELEC..... UC:AVY, A11, A13, A14, A15, A20, A24, A25, A26, A27, B16, B17, B18, HVY, H11, H13, H14,	8

SECTION II			TM9-2320-280-24P			
(1)	(2)	(3)	(4)	(5)	(6)	(7)
ITEM	SMR			PART		
NO	CODE	NSN	CAGEC	NUMBER	DESCRIPTION AND USABLE ON CODES(UC)	QTY
32	PAOZZ	5935004626603	96906	MS27142-2	H15,H16,H17,H18,H20,H21,H24,H25,H26, H27,H28,MMM CONNECTOR, PLUG, ELEC.....	4
					UOC:AVY,A11,A13,A14,A15,A20,A24,A25, A26,A27,B16,B17,B18,HVY,H11,H13,H14, H15,H16,H17,H18,H20,H21,H24,H25,H26, H27,H28,MMM	
33	PAFZZ	5340006899514	96906	MS21333-70	CLAMP, LOOP.....	1
					UOC:AVY,A11,A13,A14,A15,A20,A24,A25, A26,A27,B16,B17,B18,HVY,H11,H13,H14, H15,H16,H17,H18,H20,H21,H24,H25,H26, H27,H28,MMM	

END OF FIGURE

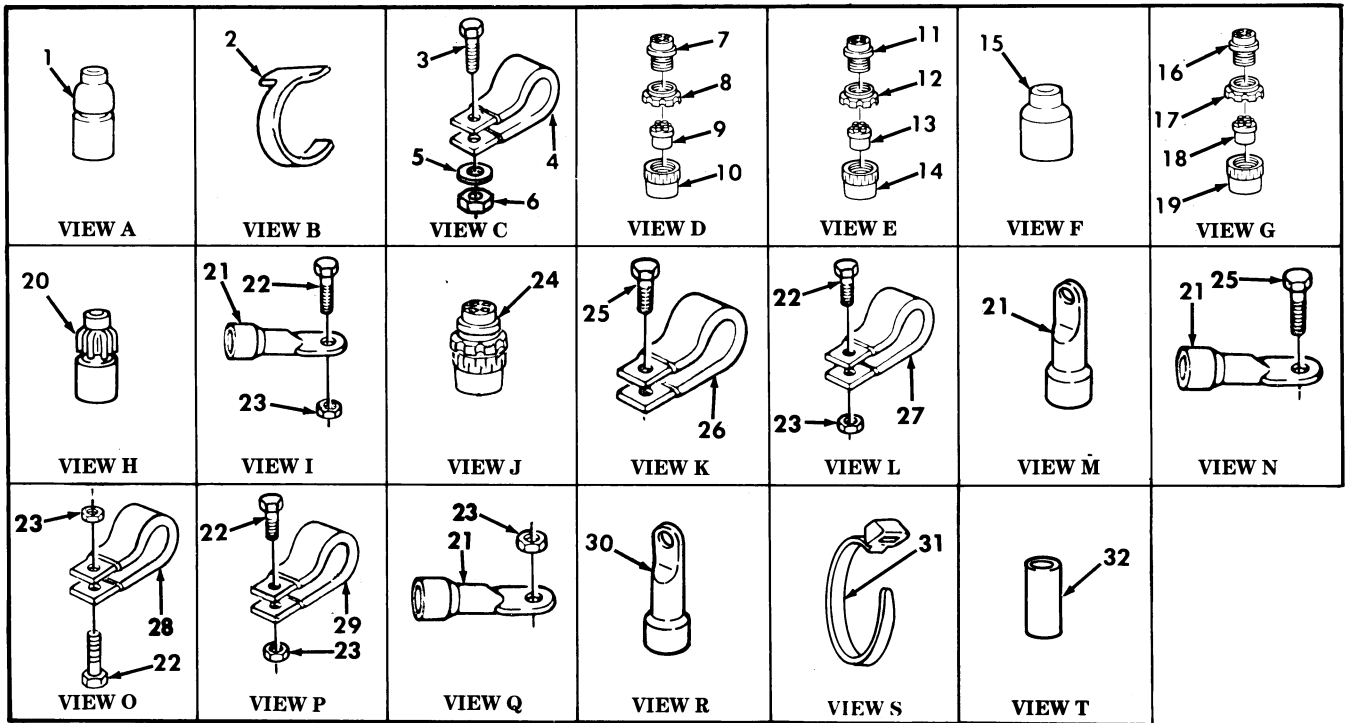
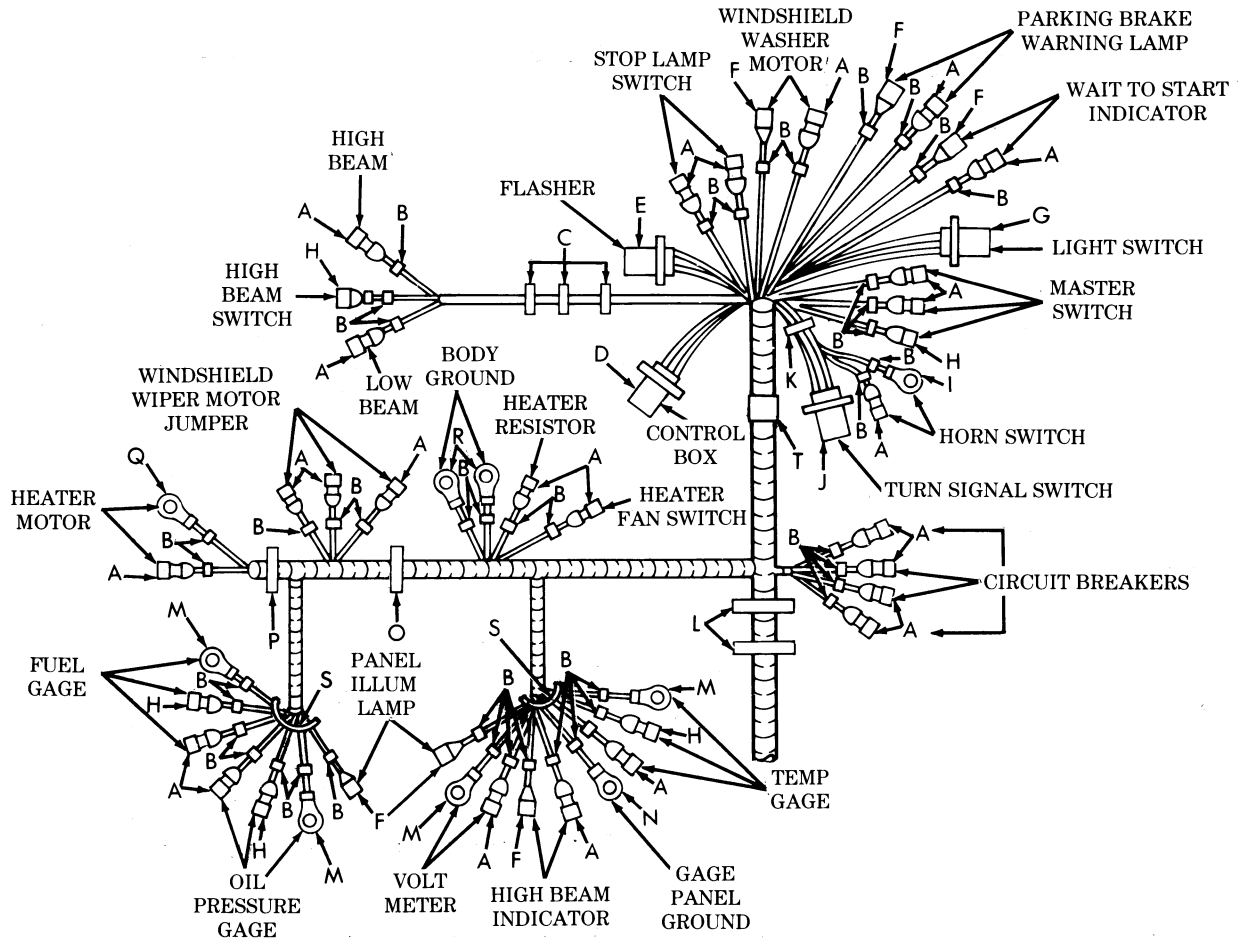

Figure 85. Body Wiring Harness - Partial View.



SECTION II			TM9-2320-280-24P			
(1)	(2)	(3)	(4)	(5)	(6)	(7)
ITEM NO	SMR CODE	NSN	CAGEC	PART NUMBER	DESCRIPTION AND USABLE ON CODES(UC)	QTY
					GROUP 0613 HULL OR CHASSIS WIRING HARNESS	
					FIG. 85 BODY WIRING HARNESS-PARTIAL VIEW	
1	PAOZA	5935001677775	96906	MS27144-1	CONNECTOR, PLUG, ELEC..... UOC:AVY, A11, A13, A14, A15, A20, A24, A25, A26, A27, B16, B17, B18, HVY, H11, H13, H14, H15, H16, H17, H18, H20, H21, H24, H25, H26, H27, H28, MMM	25
2	PAOZZ	9905010138723	81349	M43436/3-1	BAND, MARKER..... UOC:AVY, A11, A13, A14, A15, A20, A24, A25, A26, A27, B16, B17, B18, HVY, H11, H13, H14, H15, H16, H17, H18, H20, H21, H24, H25, H26, H27, H28, MMM	45
3	PAFZZ	5305002406668	96906	MS51849-78	SCREW, MACHINE #10-24 X 1.00..... UOC:AVY, A11, A13, A14, A15, A20, A24, A25, A26, A27, B16, B17, B18, HVY, H11, H13, H14, H15, H16, H17, H18, H20, H21, H24, H25, H26, H27, H28, MMM	3
4	PAFZZ	5340006899514	96906	MS21333-70	CLAMP, LOOP..... UOC:AVY, A11, A13, A14, A15, A20, A24, A25, A26, A27, B16, B17, B18, HVY, H11, H13, H14, H15, H16, H17, H18, H20, H21, H24, H25, H26, H27, H28, MMM	3
5	PAFZZ	5310012538951	34623	5593294	WASHER, FLAT #10..... UOC:AVY, A11, A13, A14, A15, A20, A24, A25, A26, A27, B16, B17, B18, HVY, H11, H13, H14, H15, H16, H17, H18, H20, H21, H24, H25, H26, H27, H28, MMM	3
6	PAFZZ	5310009349764	96906	MS35649-205	NUT, PLAIN, HEXAGON #10-24..... UOC:AVY, A11, A13, A14, A15, A20, A24, A25, A26, A27, B16, B17, B18, HVY, H11, H13, H14, H15, H16, H17, H18, H20, H21, H24, H25, H26, H27, H28, MMM	3
7	PAFZZ	5935006143959	77820	10-42622-235	CONNECTOR, PLUG, ELEC..... UOC:AVY, A11, A13, A14, A15, A20, A24, A25, A26, A27, B16, B17, B18, HVY, H11, H13, H14, H15, H16, H17, H18, H20, H21, H24, H25, H26, H27, H28, MMM	1
8	PAFZZ	5310006559860	19207	8701325	NUT, SLEEVE..... UOC:AVY, A11, A13, A14, A15, A20, A24, A25, A26, A27, B16, B17, B18, HVY, H11, H13, H14, H15, H16, H17, H18, H20, H21, H24, H25, H26, H27, H28, MMM	1
9	PAFZZ	5365007722322	19207	7722322	BUSHING, NONMETALLIC..... UOC:AVY, A11, A13, A14, A15, A20, A24, A25, A26, A27, B16, B17, B18, HVY, H11, H13, H14, H15, H16, H17, H18, H20, H21, H24, H25, H26, H27, H28, MMM	1
10	PAFZZ	5935003339414	19207	7723308	NUT, BUSHING RETAINE 1.25 X 18..... UOC:AVY, A11, A13, A14, A15, A20, A24, A25,	1

SECTION II			TM9-2320-280-24P			
(1)	(2)	(3)	(4)	(5)	(6)	(7)
ITEM	SMR			PART		
NO	CODE	NSN	CAGEC	NUMBER	DESCRIPTION AND USABLE ON CODES(UOC)	QTY
11	PAFZZ	5935006059322	80064	1755683	A26,A27,B16,B17,B18,HVY,H11,H13,H14, H15,H16,H17,H18,H20,H21,H24,H25,H26, H27,H28,MMM CONNECTOR,PLUG,ELEC.....	1
					UOC:AVY,A11,A13,A14,A15,A20,A24,A25, A26,A27,B16,B17,B18,HVY,H11,H13,H14, H15,H16,H17,H18,H20,H21,H24,H25,H26, H27,H28,MMM	
12	PAFZZ	5975006977769	19207	7527645	NUT,COUPLING,ELECTR 1.00-20.....	1
					UOC:AVY,A11,A13,A14,A15,A20,A24,A25, A26,A27,B16,B17,B18,HVY,H11,H13,H14, H15,H16,H17,H18,H20,H21,H24,H25,H26, H27,H28,MMM	
13	PAFZZ	5935007722344	77820	10-40817-010	INSERT,ELECTRICAL C.....	1
					UOC:AVY,A11,A13,A14,A15,A20,A24,A25, A26,A27,B16,B17,B18,HVY,H11,H13,H14, H15,H16,H17,H18,H20,H21,H24,H25,H26, H27,H28,MMM	
14	PAFZZ	5935007723307	19204	7723307	NUT,BUSHING RETAINE 7/8-20.....	1
					UOC:AVY,A11,A13,A14,A15,A20,A24,A25, A26,A27,B16,B17,B18,HVY,H11,H13,H14, H15,H16,H17,H18,H20,H21,H24,H25,H26, H27,H28,MMM	
15	PAOZZ	5935004626603	96906	MS27142-2	CONNECTOR,PLUG,ELEC.....	6
					UOC:AVY,A11,A13,A14,A15,A20,A24,A25, A26,A27,B16,B17,B18,HVY,H11,H13,H14, H15,H16,H17,H18,H20,H21,H24,H25,H26, H27,H28,MMM	
16	PAFZZ	5935006862599	19207	8724258	CONNECTOR,PLUG,ELEC.....	1
					UOC:AVY,A11,A13,A14,A15,A20,A24,A25, A26,A27,B16,B17,B18,HVY,H11,H13,H14, H15,H16,H17,H18,H20,H21,H24,H25,H26, H27,H28,MMM	
17	PAFZZ	5975007716634	19207	7716634	NUT,COUPLING,ELECTR 1.75 X 18.....	1
					UOC:AVY,A11,A13,A14,A15,A20,A24,A25, A26,A27,B16,B17,B18,HVY,H11,H13,H14, H15,H16,H17,H18,H20,H21,H24,H25,H26, H27,H28,MMM	
18	PAFZZ	5365000905426	19207	7722333	BUSHING,NONMETALLIC.....	1
					UOC:AVY,A11,A13,A14,A15,A20,A24,A25, A26,A27,B16,B17,B18,HVY,H11,H13,H14, H15,H16,H17,H18,H20,H21,H24,H25,H26, H27,H28,MMM	
19	PAFZZ	5310003936685	19207	7723309	NUT,PLAIN,KNURLED 1.625 X 18.....	1
					UOC:AVY,A11,A13,A14,A15,A20,A24,A25, A26,A27,B16,B17,B18,HVY,H11,H13,H14, H15,H16,H17,H18,H20,H21,H24,H25,H26, H27,H28,MMM	
20	PAOZA	5935001846707	96906	MS27144-3	CONNECTOR,PLUG,ELEC.....	5
					UOC:AVY,A11,A13,A14,A15,A20,A24,A25, A26,A27,B16,B17,B18,HVY,H11,H13,H14, H15,H16,H17,H18,H20,H21,H24,H25,H26, H27,H28,MMM	

SECTION II			TM9-2320-280-24P				
(1)	(2)	(3)	(4)	(5)	(6)	(7)	
ITEM NO	SMR CODE	NSN	CAGEC	PART NUMBER	DESCRIPTION AND USABLE ON CODES(UC)	QTY	
21	PAOZZ	5940007056708	56501	TG8	TERMINAL, LUG..... UC:AVY, A11, A13, A14, A15, A20, A24, A25, A26, A27, B16, B17, B18, HVY, H11, H13, H14, H15, H16, H17, H18, H20, H21, H24, H25, H26, H27, H28, MMM	7	
22	PAFZZ	5305005829501	82386	410-63	SCREW, CAP, HEXAGON H #10-32 X 1/2... UC:AVY, A11, A13, A14, A15, A20, A24, A25, A26, A27, B16, B17, B18, HVY, H11, H13, H14, H15, H16, H17, H18, H20, H21, H24, H25, H26, H27, H28, MMM	8	
23	PAFZZ	5310001249265	24617	271169	NUT, PLAIN, ASSEMBLED #10-32..... UC:AVY, A11, A13, A14, A15, A20, A24, A25, A26, A27, B16, B17, B18, HVY, H11, H13, H14, H15, H16, H17, H18, H20, H21, H24, H25, H26, H27, H28, MMM	9	
24	PAFZZ	5935011846417	19207	11668591	CONNECTOR, PLUG, ELEC..... UC:AVY, A11, A13, A14, A15, A20, A24, A25, A26, A27, B16, B17, B18, HVY, H11, H13, H14, H15, H16, H17, H18, H20, H21, H24, H25, H26, H27, H28, MMM	1	
25	PAFZZ	5305012046502	34623	5588064	SCREW #10-32 X 1/2..... UC:AVY, A11, A13, A14, A15, A20, A24, A25, A26, A27, B16, B17, B18, HVY, H11, H13, H14, H15, H16, H17, H18, H20, H21, H24, H25, H26, H27, H28, MMM	2	
26	PAFZZ	5340000913790	96906	MS21333-72	CLAMP, LOOP..... UC:AVY, A11, A13, A14, A15, A20, A24, A25, A26, A27, B16, B17, B18, HVY, H11, H13, H14, H15, H16, H17, H18, H20, H21, H24, H25, H26, H27, H28, MMM	1	
27	PAFZZ	5340012097799	34623	5583717	CLAMP, LOOP..... UC:AVY, A11, A13, A14, A15, A20, A24, A25, A26, A27, B16, B17, B18, HVY, H11, H13, H14, H15, H16, H17, H18, H20, H21, H24, H25, H26, H27, H28, MMM	2	
28	PAFZZ	5340007647051	96906	MS21333-69	CLAMP, LOOP..... UC:AVY, A11, A13, A14, A15, A20, A24, A25, A26, A27, B16, B17, B18, HVY, H11, H13, H14, H15, H16, H17, H18, H20, H21, H24, H25, H26, H27, H28, MMM	1	
29	PAFZZ	5340000572904	96906	MS21333-71	CLAMP, LOOP..... UC:AVY, A11, A13, A14, A15, A20, A24, A25, A26, A27, B16, B17, B18, HVY, H11, H13, H14, H15, H16, H17, H18, H20, H21, H24, H25, H26, H27, H28, MMM	1	
30	PAOZZ	5940007056709	56501	TG9	TERMINAL, LUG..... UC:AVY, A11, A13, A14, A15, A20, A24, A25, A26, A27, B16, B17, B18, HVY, H11, H13, H14, H15, H16, H17, H18, H20, H21, H24, H25, H26, H27, H28, MMM	2	
31	PAOZZ	5975009856630	96906	MS3367-3-0	STRAP, TIEDOWN, ELECT..... UC:AVY, A11, A13, A14, A15, A20, A24, A25, A26, A27, B16, B17, B18, HVY, H11, H13, H14,	2	

SECTION II			TM9-2320-280-24P			
(1)	(2)	(3)	(4)	(5)	(6)	(7)
ITEM	SMR			PART		
NO	CODE	NSN	CAGEC	NUMBER	DESCRIPTION AND USABLE ON CODES(UC)	QTY
32	MOOZZ		81349	M23053/4-303-0-1	H15,H16,H17,H18,H20,H21,H24,H25,H26, H27,H28,MMM INSULATION SLEEVING MAKE FROM INSULATION,P/N M23053/4-303-0,1 INCH LONG..... UOC:AVY,A11,A13,A14,A15,A20,A24,A25, A26,A27,B16,B17,B18,HVY,H11,H13,H14, H15,H16,H17,H18,H20,H21,H24,H25,H26, H27,H28,MMM	1

END OF FIGURE

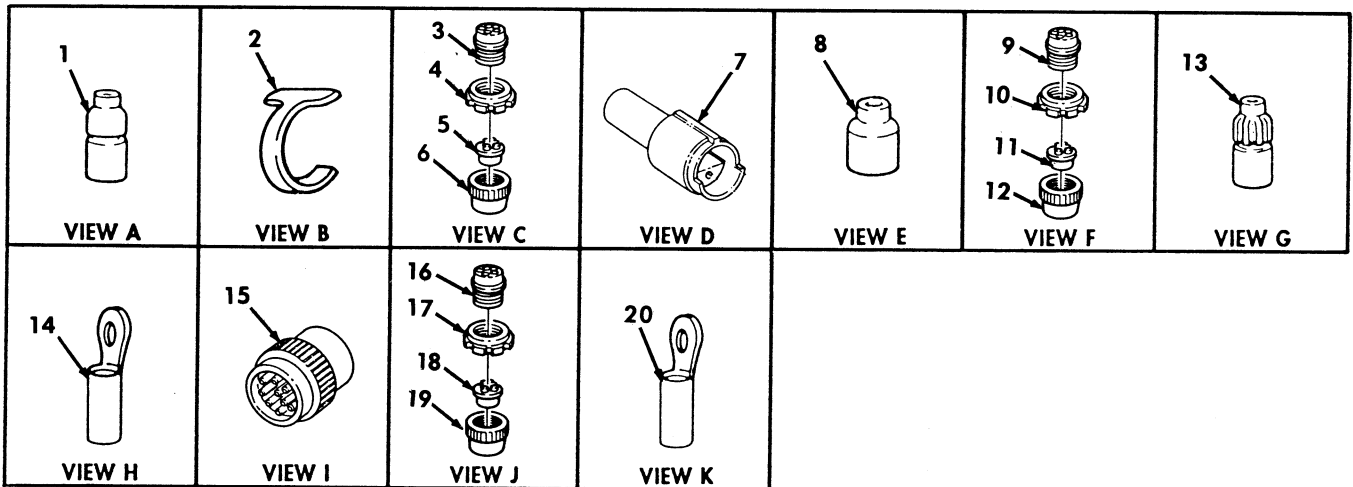
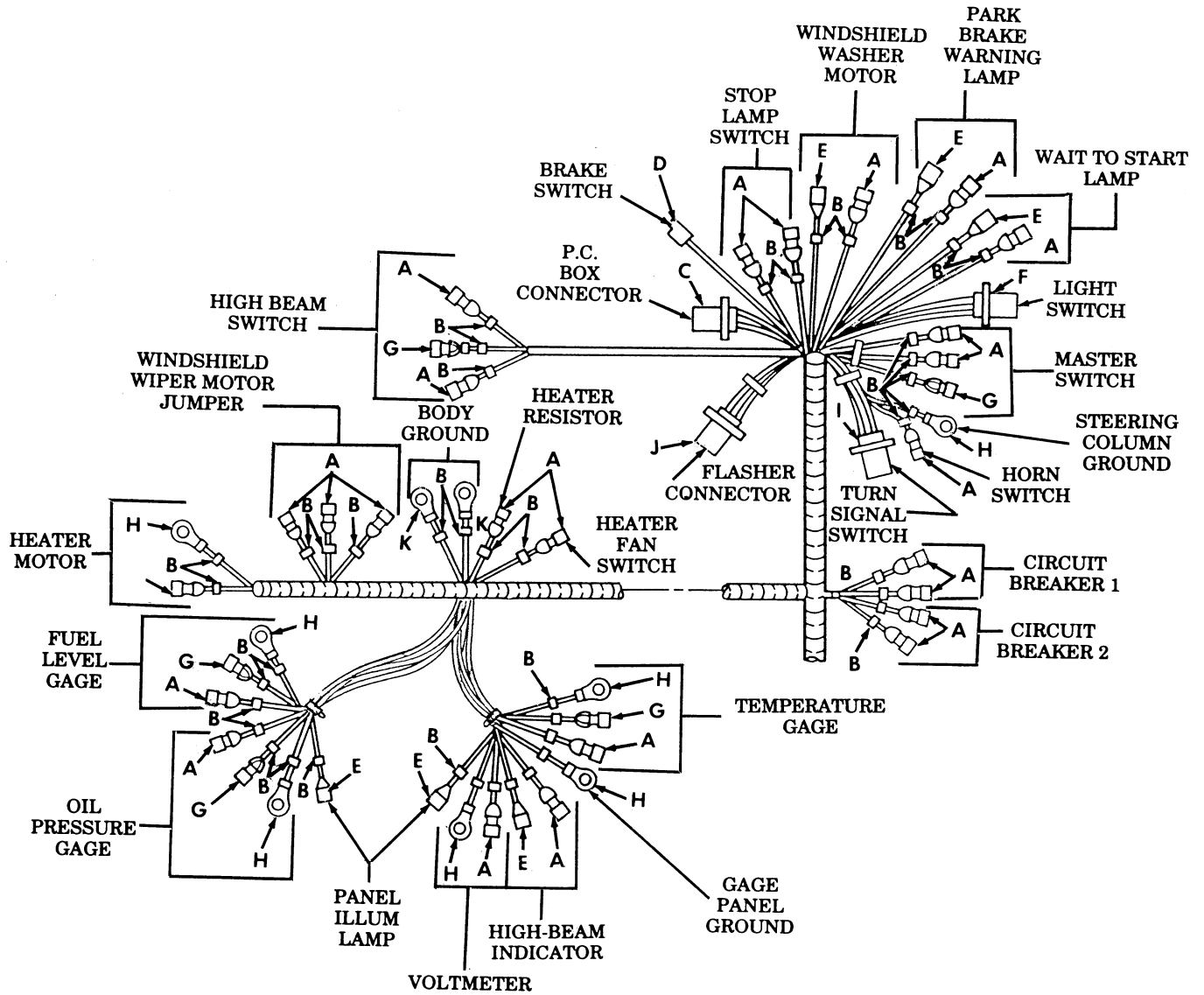

Figure 86. A2 Body Wiring Harness (Sheet 1 of 2).

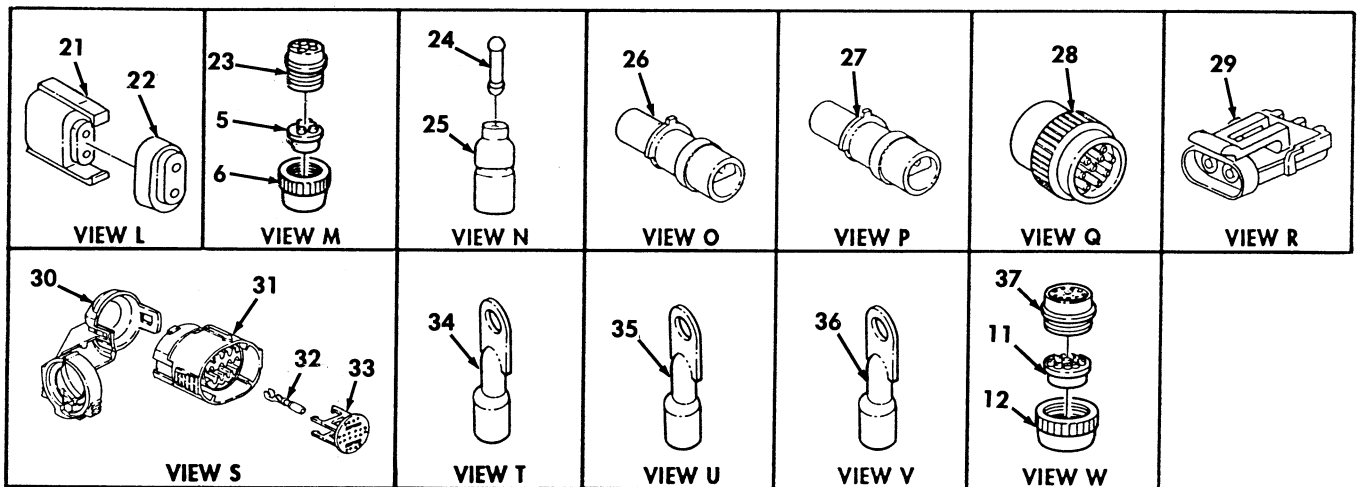
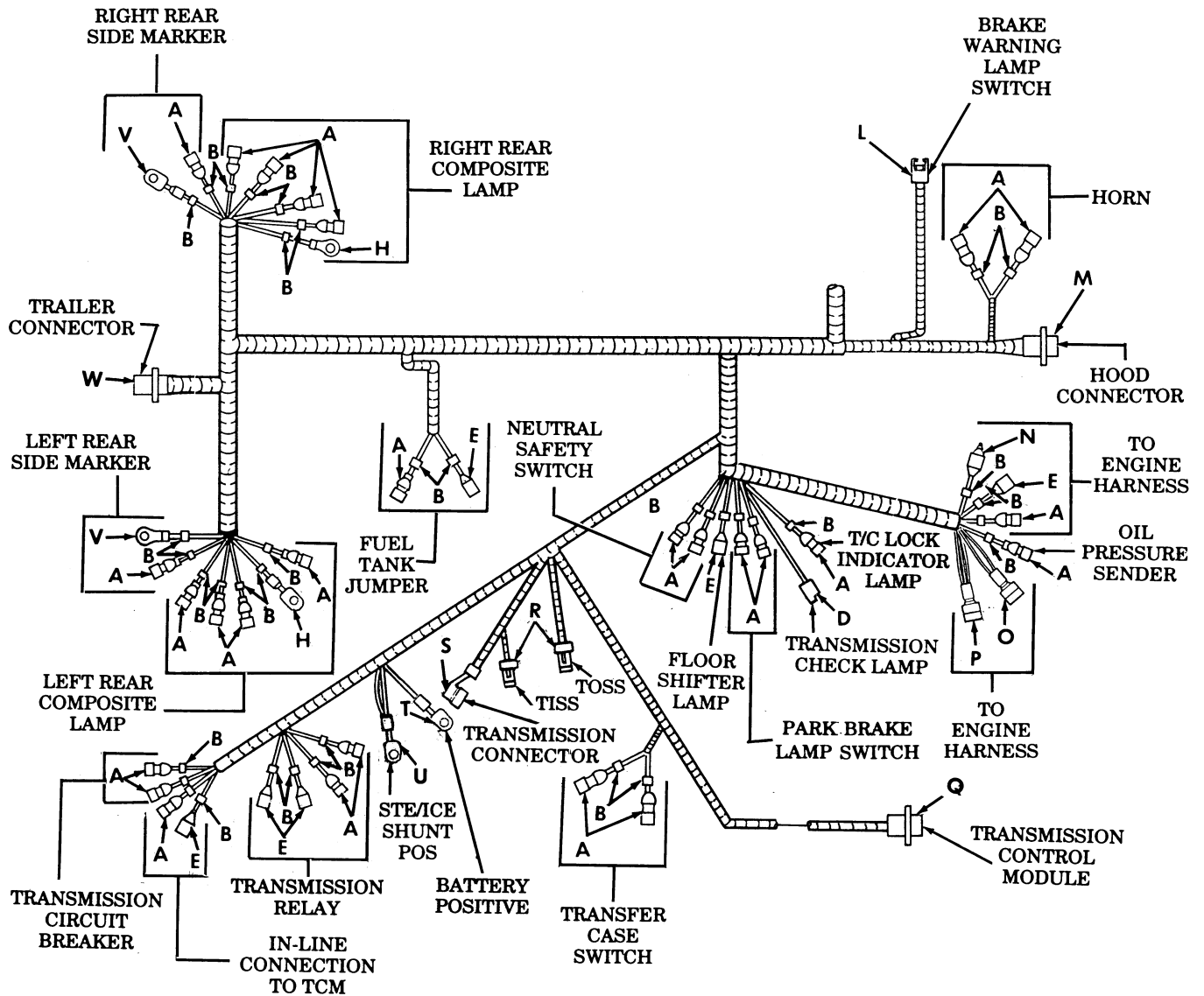

Figure 86. A2 Body Wiring Harness (Sheet 2 of 2).

SECTION II			TM9-2320-280-24P			
(1)	(2)	(3)	(4)	(5)	(6)	(7)
ITEM	SMR			PART		
NO	CODE	NSN	CAGEC	NUMBER	DESCRIPTION AND USABLE ON CODES(UOC)	QTY
GROUP 0613 HULL OR CHASSIS WIRING HARNESS						
FIG. 86 A2 BODY WIRING HARNESS						
1	PAOZA	5935001677775	96906	MS27144-1	CONNECTOR, PLUG, ELEC.....	52
					UOC: BVY, B15, B20, B24, B25, C17, NNN	
2	PAOZZ	9905009457637	81349	M43436/1-4	BAND, MARKER.....	83
					UOC: BVY, B15, B20, B24, B25, C17, NNN	
3	PAFZZ	5935006143959	77820	10-042622-23S	CONNECTOR, PLUG, ELEC.....	1
					UOC: BVY, B15, B20, B24, B25, C17, NNN	
4	PAFZZ	5310006559860	19207	8701325	NUT, SLEEVE.....	1
					UOC: BVY, B15, B20, B24, B25, C17, NNN	
5	PAFZZ	5365007722322	19207	7722322	BUSHING, NONMETALLIC.....	2
					UOC: BVY, B15, B20, B24, B25, C17, NNN	
6	PAFZZ	5935003339414	19207	7723308	NUT, BUSHING RETAINE.....	2
					UOC: BVY, B15, B20, B24, B25, C17, NNN	
7	PAOZZ	5999011508808	45152	126488A	CONTACT, ELECTRICAL.....	2
					UOC: BVY, B15, B20, B24, B25, C17, NNN	
8	PAOZZ	5935004626603	96906	MS27142-2	CONNECTOR, PLUG, ELEC.....	9
					UOC: BVY, B15, B20, B24, B25, C17, NNN	
9	PAFZZ	5935006862599	19207	8724258	CONNECTOR, PLUG, ELEC.....	1
					UOC: BVY, B15, B20, B24, B25, C17, NNN	
10	PAFZZ	5975007716634	19207	7716634	NUT, COUPLING, ELECTR.....	1
					UOC: BVY, B15, B20, B24, B25, C17, NNN	
11	PAFZZ	5365000905426	19207	7722333	BUSHING, NONMETALLIC.....	2
					UOC: BVY, B15, B20, B24, B25, C17, NNN	
12	PAFZZ	5310003936685	19207	7723309	NUT, PLAIN, KNURLED.....	2
					UOC: BVY, B15, B20, B24, B25, C17, NNN	
13	PAOZA	5935001846707	96906	MS27144-3	CONNECTOR, PLUG, ELEC.....	5
					UOC: BVY, B15, B20, B24, B25, C17, NNN	
14	PAOZZ	5940007056708	56501	TG8	TERMINAL, LUG.....	8
					UOC: BVY, B15, B20, B24, B25, C17, NNN	
15	PAFZZ	5935011846417	19207	11668591	CONNECTOR, PLUG, ELEC.....	1
					UOC: BVY, B15, B20, B24, B25, C17, NNN	
16	PAFZZ	5935006059322	80064	1755683	CONNECTOR, PLUG, ELEC.....	1
					UOC: BVY, B15, B20, B24, B25, C17, NNN	
17	PAFZZ	5975006977769	19207	7527645	NUT, COUPLING, ELECTR.....	1
					UOC: BVY, B15, B20, B24, B25, C17, NNN	
18	PAFZZ	5935007722344	77820	10-40817-010	INSERT, ELECTRICAL C.....	1
					UOC: BVY, B15, B20, B24, B25, C17, NNN	
19	PAFZZ	5935007723307	19204	7723307	NUT, BUSHING RETAINE.....	1
					UOC: BVY, B15, B20, B24, B25, C17, NNN	
20	PAOZZ	5940007056709	56501	TG9	TERMINAL, LUG.....	2
					UOC: BVY, B15, B20, B24, B25, C17, NNN	
21	PAOZZ	5935012380543	19207	12340362	CONNECTOR, PLUG, ELEC.....	1
					UOC: BVY, B15, B20, B24, B25, C17, NNN	
22	PAFZZ	5935014428569	19207	12460097-1	CONNECTOR, MODULAR P.....	1
					UOC: BVY, B15, B20, B24, B25, C17, NNN	
23	PAFZZ	5935007722353	19207	7722353	CONNECTOR, RECEPTACL.....	1
					UOC: BVY, B15, B20, B24, B25, C17, NNN	
24	PAOZZ	5935002140904	19207	7982907	DUMMY CONNECTOR, PLU.....	1
					UOC: BVY, B15, B20, B24, B25, C17, NNN	

SECTION II			TM9-2320-280-24P			
(1)	(2)	(3)	(4)	(5)	(6)	(7)
ITEM	SMR			PART		
NO	CODE	NSN	CAGEC	NUMBER	DESCRIPTION AND USABLE ON CODES (UOC)	QTY
25	PAOZZ	5935008338561	19207	8338561	SHELL, ELECTRICAL CO.....	1
					UOC: BVY, B15, B20, B24, B25, C17, NNN	
26	PAFZZ	5935011508322	11083	7N7782	CONNECTOR BODY, PLUG.....	1
					UOC: BVY, B15, B20, B24, B25, C17, NNN	
27	PAFZZ	5935011495165	11083	7N9738	CONNECTOR BODY, PLUG.....	1
					UOC: BVY, B15, B20, B24, B25, C17, NNN	
28	PAFZA	5935013970201	71468	CA3106E28-21S-B-	CONNECTOR, PLUG, ELEC.....	1
				F80	UOC: BVY, B15, B20, B24, B25, C17, NNN	
29	PAFZZ	5935014439124	77060	12078084	CONNECTOR, RECEPTACL.....	2
					UOC: BVY, B15, B20, B24, B25, C17, NNN	
30	PAFZZ	5935014455599	77060	12160490	CONNECTOR, PLUG, ELEC.....	1
					UOC: BVY, B15, B20, B24, B25, C17, NNN	
31	PAFZZ	5940014426298	77060	12084912	TERMINAL, LUG.....	1
					UOC: BVY, B15, B20, B24, B25, C17, NNN	
32	PAFZZ	5935014455144	77060	12160494	INSERT, ELECTRICAL C.....	1
					UOC: BVY, B15, B20, B24, B25, C17, NNN	
33	PAFZZ	5340014424876	19207	12460130	CLIP, SPRING TENSION.....	1
					UOC: BVY, B15, B20, B24, B25, C17, NNN	
34	PAOZZ	5940001139826	98410	C-840-38	TERMINAL, LUG.....	1
					UOC: BVY, B15, B20, B24, B25, C17, NNN	
35	PAOZZ	5940007056702	56501	TG2	TERMINAL, LUG.....	1
					UOC: BVY, B15, B20, B24, B25, C17, NNN	
36	PAOZZ	5940007056711	56501	TG11	TERMINAL, LUG.....	2
					UOC: BVY, B15, B20, B24, B25, C17, NNN	
37	PAFZA	5935008463884	96906	MS75021-2	CONNECTOR, RECEPTACL.....	1
					UOC: BVY, B15, B20, B24, B25, C17, NNN	

END OF FIGURE



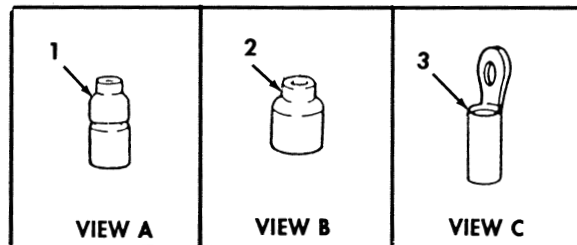
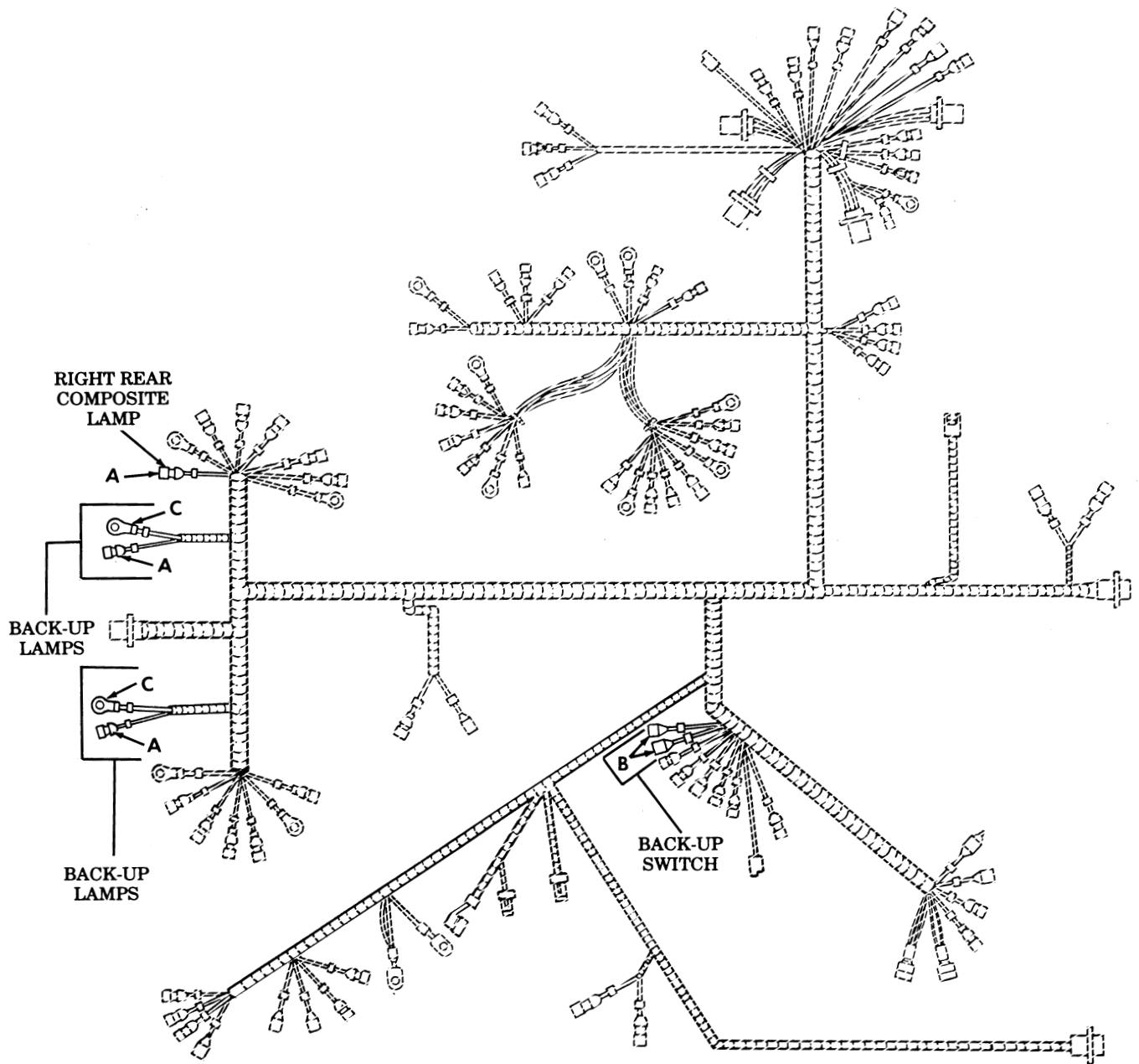

Figure 87. Ambulance Body Wiring Harness, M997A2 and M1035A2 (Sheet 1 of 2).

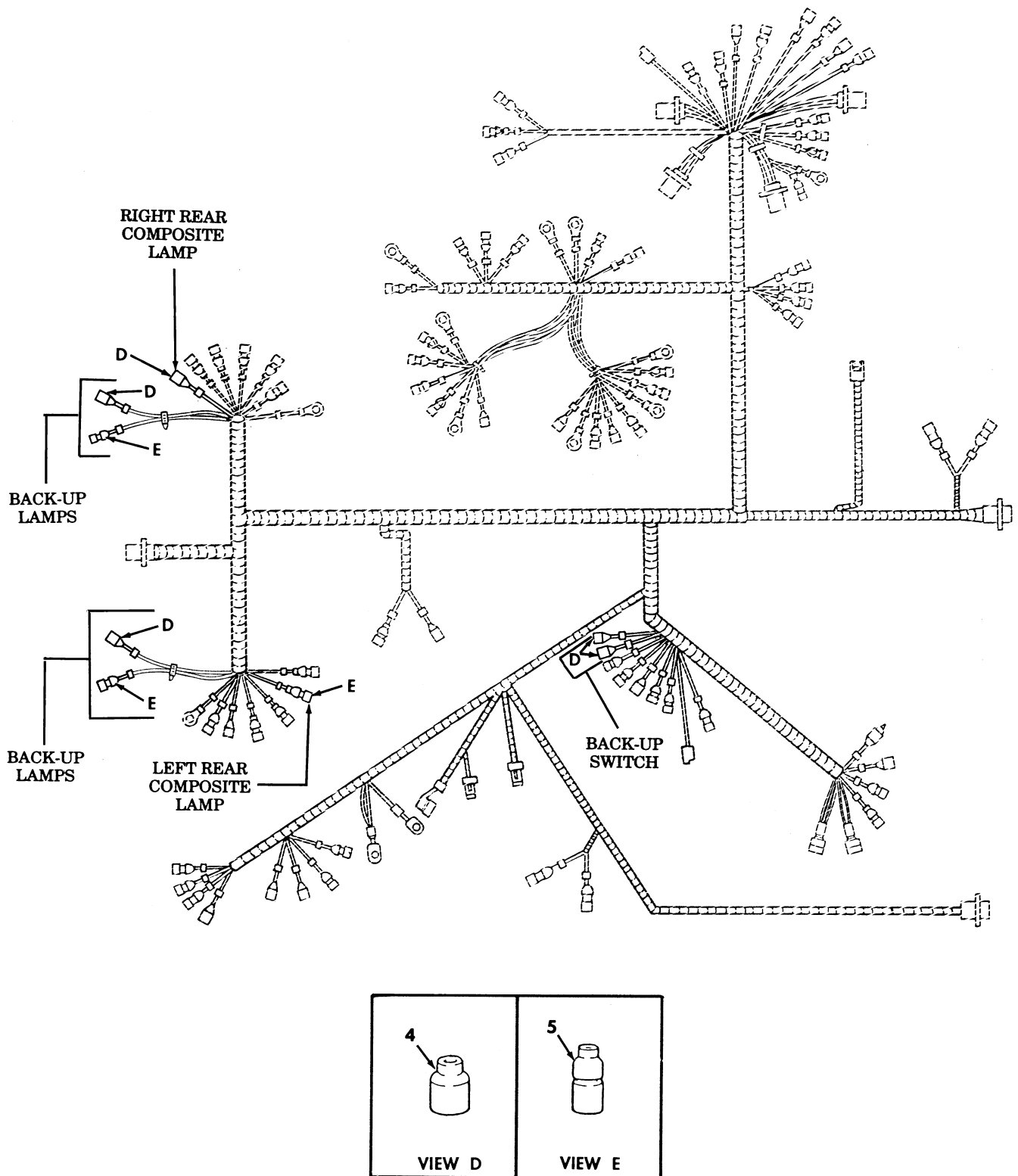

Figure 87. Ambulance Body Wiring Harness, M997A2 and M1035A2 (Sheet 2 of 2).

SECTION II			TM9-2320-280-24P			
(1)	(2)	(3)	(4)	(5)	(6)	(7)
ITEM	SMR			PART		
NO	CODE	NSN	CAGEC	NUMBER	DESCRIPTION AND USABLE ON CODES(UC)	QTY
					GROUP 0613 HULLOR CHASSIS WIRING HARNESS	
					FIG. 87 AMBULANCE BODY WIRING HARNESS,M997A2 AND M1035A2	
1	PAFZA	5935001677775	96906	MS27144-1	CONNECTOR,PLUG,ELEC.....	3
					UOC:B15	
2	PAFZZ	5935004626603	96906	MS27142-2	CONNECTOR,PLUG,ELEC.....	2
					UOC:B15	
3	PAFZZ	5940007056708	56501	TG8	TERMINAL,LUG.....	2
					UOC:B15	
4	PAFZZ	5935004626603	96906	MS27142-2	CONNECTOR,PLUG,ELEC.....	3
					UOC:B20	
5	PAFZA	5935001677775	96906	MS27144-1	CONNECTOR,PLUG,ELEC.....	5
					UOC:B20	

END OF FIGURE

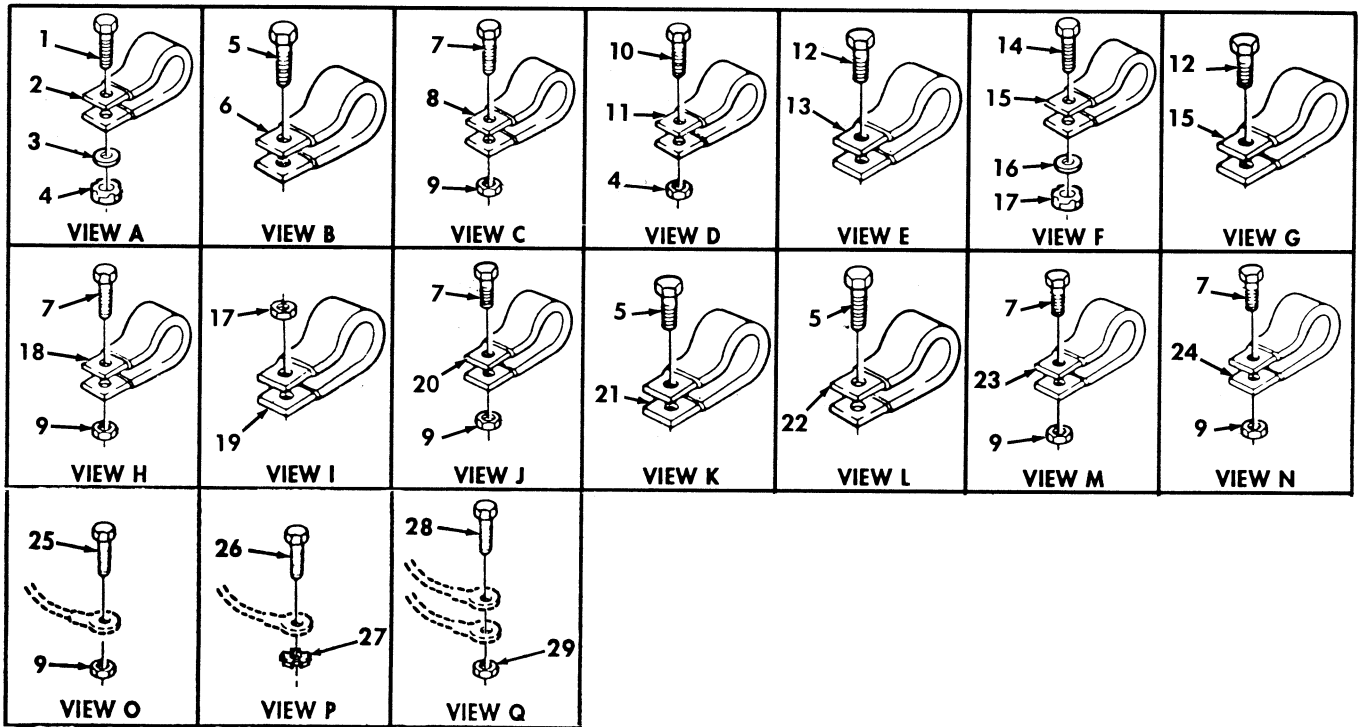
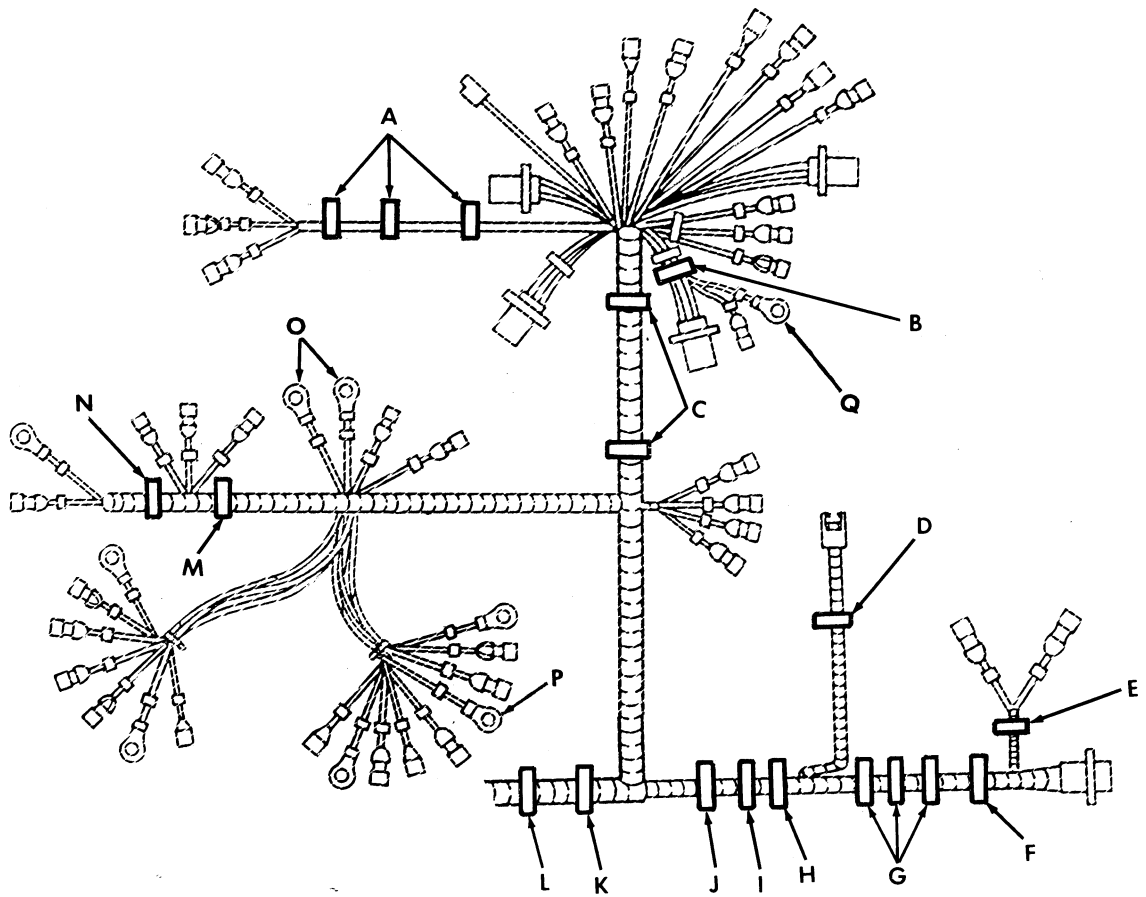

Figure 88. A2 Body Wiring Harness Installation (Sheet 1 of 2).

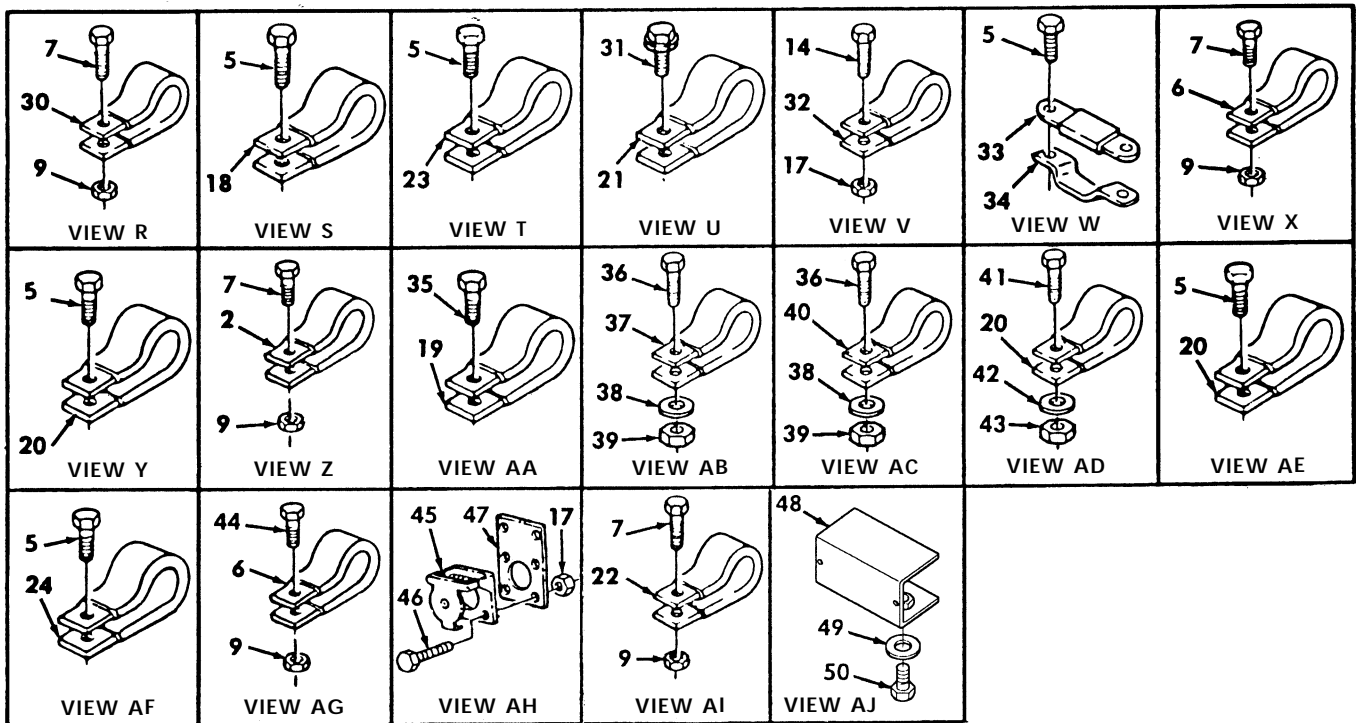
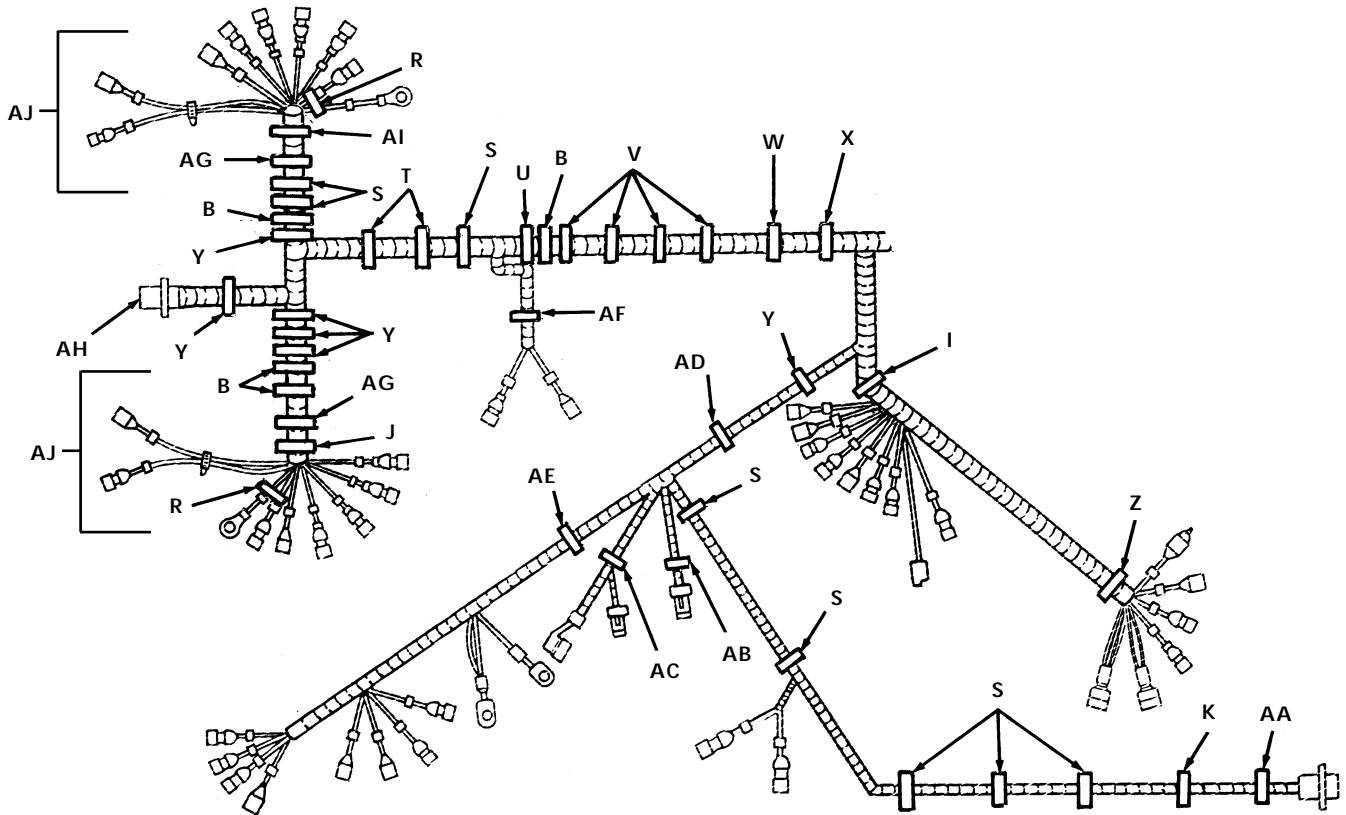

Figure 88. A2 Body Wiring Harness Installation (Sheet 2 of 2).

SECTION II			TM9-2320-280-24P			
(1)	(2)	(3)	(4)	(5)	(6)	(7)
ITEM	SMR			PART		
NO	CODE	NSN	CAGEC	NUMBER	DESCRIPTION AND USABLE ON CODES(UCO)	QTY
					GROUP 0613 HULL OR CHASSIS WIRING HARNESS	
					FIG. 88 A2 BODY WIRING HARNESS INSTALLATON	
1	PAFZZ	5305002406668	96906	MS51849-78	SCREW,MACHINE #10-24 X 1.00.....	3
					UCO:BVY,B15,B20,B24,B25,C17,NNN	
2	PAFZZ	5340006899514	96906	MS21333-70	CLAMP,LOOP.....	4
					UCO:BVY,B15,B20,B24,B25,C17,NNN	
3	PAFZZ	5310012538951	34623	5593294	WASHER,FLAT #10.....	3
					UCO:BVY,B15,B20,B24,B25,C17,NNN	
4	PAFZZ	5310002081918	24617	190254	NUT,SELF-LOCKING,HE #10-24.....	4
					UCO:BVY,B15,B20,B24,B25,C17,NNN	
5	PAFZZ	5305012596322	34623	12342499-1	SCREW,MACHINE #10-32 X 1/2.....	28
					UCO:BVY,B15,B20,B24,B25,C17,NNN	
6	PAFZZ	5340000913790	96906	MS21333-72	CLAMP,LOOP.....	8
					UCO:BVY,B15,B20,B24,B25,C17,NNN	
7	PAFZZ	5305005829501	82386	410-63	SCREW,CAP,HEXAGON H #10-32 X 1/2...	12
					UCO:BVY,B15,B20,B24,B25,C17,NNN	
8	PAFZZ	5340012097799	34623	5583717	CLAMP,LOOP.....	2
					UCO:BVY,B15,B20,B24,B25,C17,NNN	
9	PAFZZ	5310001249265	72582	271169	NUT,PLAIN,ASSEMBLED.....	14
					UCO:BVY,B15,B20,B24,B25,C17,NNN	
10	PAFZZ	5305002400194	96906	MS51849-76	SCREW,MACHINE #10-24 X 3/4.....	1
					UCO:BVY,B15,B20,B24,B25,C17,NNN	
11	PAFZZ	5340009848540	96906	MS21333-102	CLAMP,LOOP.....	1
					UCO:BVY,B15,B20,B24,B25,C17,NNN	
12	PAFZZ	5305012068401	7X677	448655	SCREW,TAPPING.....	4
					UCO:BVY,B15,B20,B24,B25,C17,NNN	
13	PAFZZ	5340008091492	81348	CMDX2-3PT573036	CLAMP,LOOP.....	1
					UCO:BVY,B15,B20,B24,B25,C17,NNN	
14	PAFZZ	5305004890743	24617	9415477	SCREW,MACHINE 1/4-20 X 3/4.....	5
					UCO:BVY,B15,B20,B24,B25,C17,NNN	
15	PAFZZ	5340000881254	96906	MS21333-104	CLAMP,LOOP.....	4
					UCO:BVY,B15,B20,B24,B25,C17,NNN	
16	PAFZZ	5310012349415	96906	MS51412-5	WASHER,FLAT 9/32.....	1
					UCO:BVY,B15,B20,B24,B25,C17,NNN	
17	PAFZZ	5310011520598	24617	271172	NUT,SELF-LOCKING,AS 1/4-20.....	15
					UCO:BVY,B15,B20,B24,B25,C17,NNN	
18	PAFZZ	5340000502740	96906	MS21333-75	CLAMP,LOOP.....	9
					UCO:BVY,B15,B20,B24,B25,C17,NNN	
19	PAFZZ	5340008091494	96906	MS21333-105	CLAMP,LOOP.....	3
					UCO:BVY,B15,B20,B24,B25,C17,NNN	
20	PAFZZ	5340009899222	96906	MS21333-74	CLAMP,LOOP.....	9
					UCO:BVY,B15,B20,B24,B25,C17,NNN	
21	PAFZZ	5340007247038	96906	MS21333-76	CLAMP,LOOP.....	3
					UCO:BVY,B15,B20,B24,B25,C17,NNN	
22	PAFZZ	5340009226300	96906	MS21333-77	CLAMP,LOOP.....	3
					UCO:BVY,B15,B20,B24,B25,C17,NNN	
23	PAFZZ	5340000572904	96906	MS21333-71	CLAMP,LOOP.....	3
					UCO:BVY,B15,B20,B24,B25,C17,NNN	
24	PAFZZ	5340007647051	96906	MS21333-69	CLAMP,LOOP.....	2
					UCO:BVY,B15,B20,B24,B25,C17,NNN	

SECTION II			TM9-2320-280-24P			
(1)	(2)	(3)	(4)	(5)	(6)	(7)
ITEM NO	SMR CODE	NSN	CAGEC	PART NUMBER	DESCRIPTION AND USABLE ON CODES(UOC)	QTY
25	PAFZZ		24617	456931	SCREW,CAP,HEXAGON H #10-32 X 1.125. UOC:BVY,B15,B20,B24,B25,C17,NNN	1
26	PAFZZ	5305012596322	34623	12342499-1	SCREW,MACHINE..... UOC:BVY,B15,B20,B24,B25,C17,NNN	1
27	PAFZZ	5310000809786	96906	MS45904-60	WASHER,LOCK..... UOC:BVY,B15,B20,B24,B25,C17,NNN	1
28	PAFZZ	5305004890743	24617	9415477	SCREW,MACHINE..... UOC:BVY,B15,B20,B24,B25,C17,NNN	1
29	PAFZZ	5310011520598	24617	271172	NUT,SELF-LOCKING,AS 1/4-20..... UOC:BVY,B15,B20,B24,B25,C17,NNN	1
30	PAFZZ	5340008437825	96906	MS21333-68	CLAMP,LOOP..... UOC:BVY,B15,B20,B24,B25,C17,NNN	3
31	PAFZZ	5305009881725	96906	MS35206-281	SCREW,MACHINE..... UOC:BVY,B15,B20,B24,B25,C17,NNN	1
32	PAFZZ	5340000572906	96906	MS21333-73	LOOP..... UOC:BVY,B15,B20,B24,B25,C17,NNN	4
33	PAFZZ	5340014436908	19207	12340666	PLATE,MOUNTING..... UOC:BVY,B15,B20,B24,B25,C17,NNN	1
34	PAFZZ	5340012134665	19207	12340665	STRAP,RETAINING..... UOC:BVY,B15,B20,B24,B25,C17,NNN	1
35	PAFZZ	5305012067219	92871	G9426241	SCREW,TAPPING..... UOC:BVY,B15,B20,B24,B25,C17,NNN	1
36	PAFZZ	5305009881725	96906	MS35206-281	SCREW,MACHINE..... UOC:BVY,B15,B20,B24,B25,C17,NNN	2
37	PAFZZ	5340008091490	96906	MS21333-98	CLAMP,LOOP..... UOC:BVY,B15,B20,B24,B25,C17,NNN	1
38	PAFZZ	5310006379541	96906	MS35338-46	WASHER,LOCK..... UOC:BVY,B15,B20,B24,B25,C17,NNN	2
39	PAFZZ	5310009971888	96906	MS35649-2252	NUT,PLAIN,HEXAGON..... UOC:BVY,B15,B20,B24,B25,C17,NNN	2
40	PAFZZ	5340000886655	96906	MS21333-101	CLAMP,LOOP..... UOC:BVY,B15,B20,B24,B25,C17,NNN	1
41	PAFZZ	5305009846212	96906	MS35206-265	SCREW,MACHINE..... UOC:BVY,B15,B20,B24,B25,C17,NNN	1
42	PAFZZ	5310009222017	72582	120217	WASHER,LOCK..... UOC:BVY,B15,B20,B24,B25,C17,NNN	1
43	PAFZZ	5310009349758	96906	MS35649-202	NUT,PLAIN,HEXAGON..... UOC:BVY,B15,B20,B24,B25,C17,NNN	1
44	PAFZZ	5305000187838	24617	187838	SCREW,CAP,HEXAGON H..... UOC:BVY,B15,B20,B24,B25,C17,NNN	2
45	PAFZZ	5935007731428	19207	7731428	COVER,ELECTRICAL CO..... UOC:BVY,B15,B20,B24,B25,C17,NNN	1
46	PAFZZ	5306000425570	24617	425570	BOLT,ASSEMBLED WASH..... UOC:BVY,B15,B20,B24,B25,C17,NNN	1
47	PAFZZ	5935014214801	19207	12339332	PLATE,RETAINING,ELE..... UOC:BVY,B15,B20,B24,B25,C17,NNN	1
48	PAFZZ	9540014725874	19207	12446933	CHANNEL,STRUCTURAL..... UOC:BVY,B15,B20,B24,B25,C17,NNN	2
49	PAFZZ	5310005435101	96906	MS35338-27	WASHER,LOCK..... UOC:BVY,B15,B20,B24,B25,C17,NNN	4
50	PAFZZ	5305000680508	80204	B1821BH025C075N	SCREW,CAP,HEXAGON H..... UOC:BVY,B15,B20,B24,B25,C17,NNN	4

END OF FIGURE

1—  
2  
thru  
6

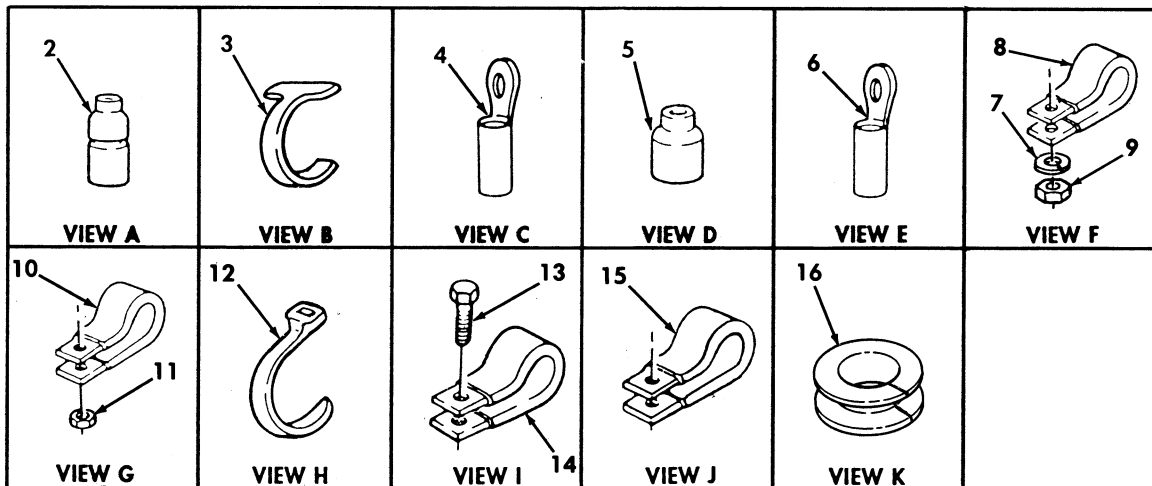
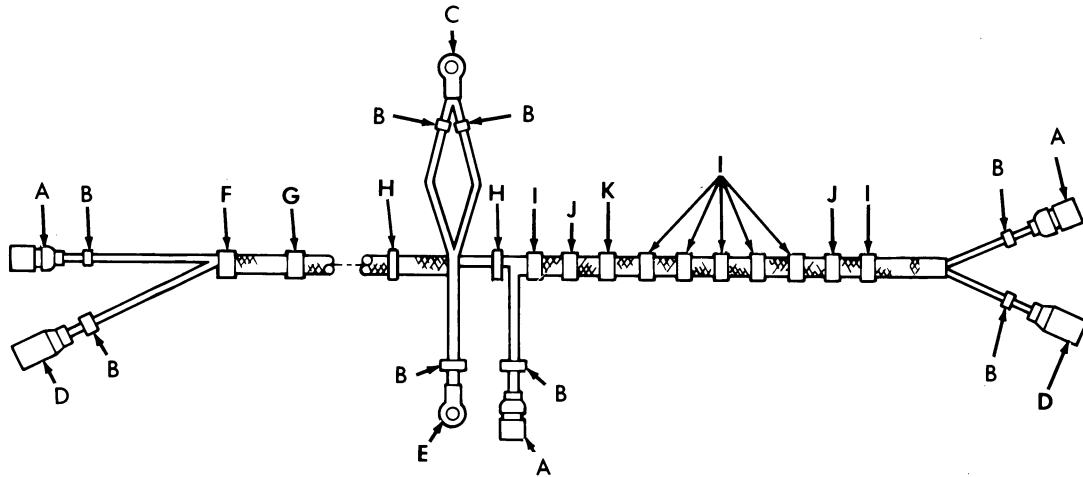

Figure 89. Air-Conditioner Jumper Cable, M997, M997A1, and M997A2 Ambulance.



SECTION II			TM9-2320-280-24P			
(1)	(2)	(3)	(4)	(5)	(6)	(7)
ITEM	SMR			PART		
NO	CODE	NSN	CAGEC	NUMBER	DESCRIPTION AND USABLE ON CODES(UOC)	QTY
					GROUP 0613 HULL OR CHASSIS WIRING HARNESS	
					FIG. 89 AIR-CONDITIONER JUMPER CABLE, M997, M997A1, AND M997A2 AMBULANCE	
1	PFOOO	6150012690067	19207	12341000	WIRING HARNESS.....	1
					UOC:A15, B15, H15	
2	PAOZA	5935001677775	96906	MS27144-1	.CONNECTOR, PLUG, ELEC.....	3
					UOC:A15, B15, H15	
3	PAOZZ	9905010138723	81349	M43436/3-1	.BAND, MARKER.....	8
					UOC:A15, B15, H15	
4	PAOZZ	5940012691816	91094	100951-D02	.TERMINAL, LUG.....	1
					UOC:A15, B15, H15	
5	PAOZZ	5935004626603	96906	MS27142-2	.CONNECTOR, PLUG, ELEC.....	2
					UOC:A15, B15, H15	
6	PAOZZ	5940007056709	56501	TG9	.TERMINAL, LUG.....	1
					UOC:A15, B15, H15	
7	PAOZZ	5310006379541	81718	H2525M	WASHER, LOCK 3/8.....	1
					UOC:A15, B15, H15	
8	PAOZZ	5340009546014	96906	MS21333-121	CLAMP, LOOP.....	1
					UOC:A15, B15, H15	
9	PAOZZ	5310007320558	96906	MS51967-8	NUT, PLAIN, HEXAGON 3/8-16.....	1
					UOC:A15, B15, H15	
10	PAOZZ	5340009848540	96906	MS21333-102	CLAMP, LOOP.....	1
					UOC:A15, B15, H15	
11	PAOZZ	5310012538380	34623	5592818	NUT.....	1
					UOC:A15, B15, H15	
12	PAOZZ	5975009856630	96906	MS3367-3-0	STRAP, TIEDOWN, ELECT.....	2
					UOC:A15, B15, H15	
13	PAOZZ	5305001798946	24617	9418346	SCREW, MACHINE.....	7
					UOC:A15, B15, H15	
14	PAOZZ	5340008437825	96906	MS21333-68	CLAMP, LOOP.....	7
					UOC:A15, B15, H15	
15	PAOZZ	5340009936207	96906	MS21333-99	CLAMP, LOOP.....	2
					UOC:A15, B15, H15	
16	PAOZZ	5325001849846	81349	C3030	GROMMET, NONMETALLIC.....	1
					UOC:A15, B15, H15	

END OF FIGURE

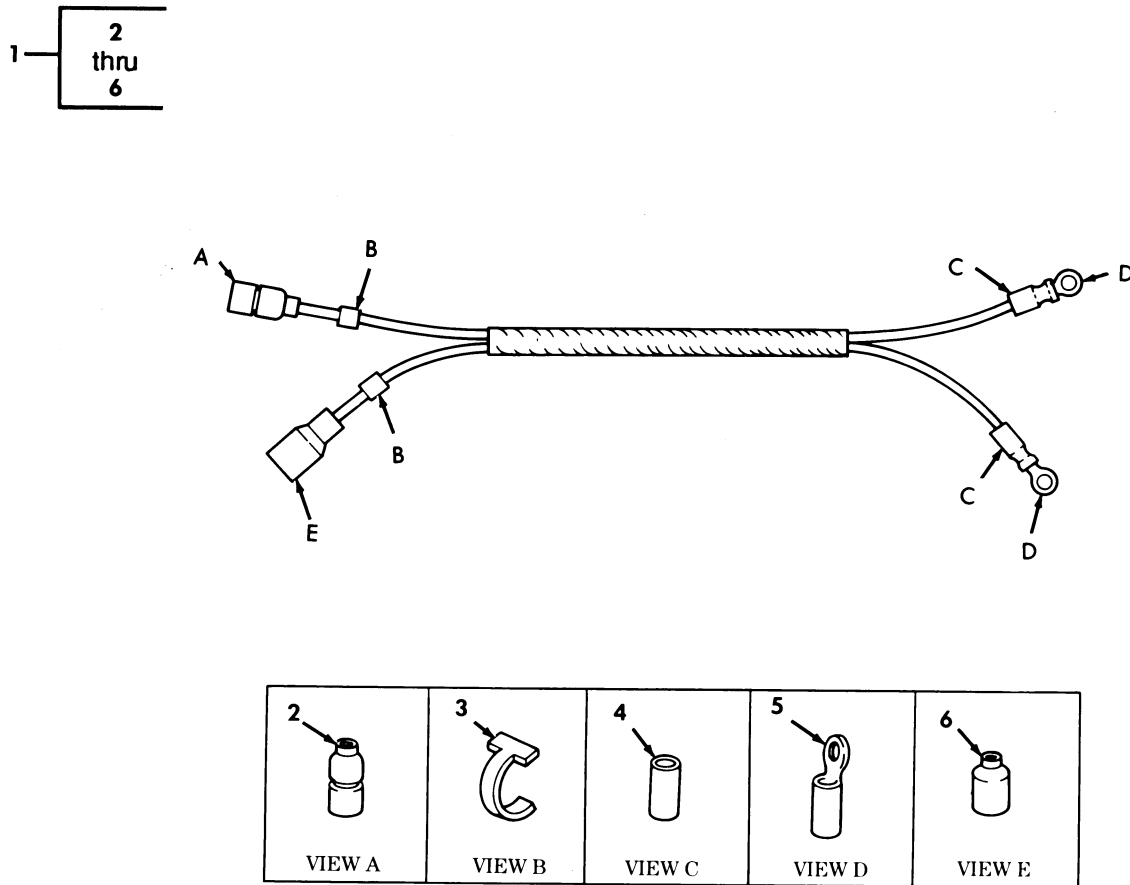
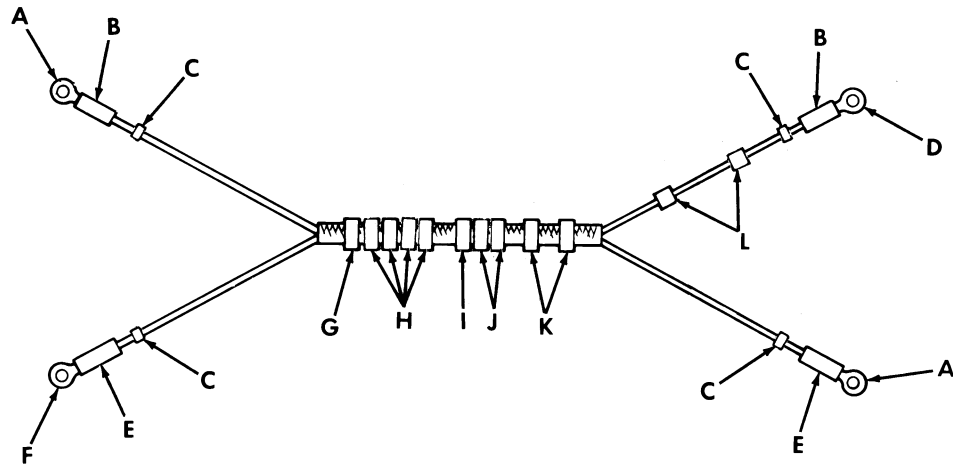

Figure 90. Wiring Harness, Blackout Jumper Switch, M996, M996A1, M997, M997A1, and M997A2.

SECTION II			TM9-2320-280-24P			
(1)	(2)	(3)	(4)	(5)	(6)	(7)
ITEM	SMR			PART		
NO	CODE	NSN	CAGEC	NUMBER	DESCRIPTION AND USABLE ON CODES(UC)	QTY
					GROUP 0613 HULL OR CHASSIS WIRING HARNESS	
					FIG. 90 WIRING HARNESS, BLACKOUT JUMPER SWITCH, M996, M996A1, M997, M997A1, AND M997A2 AMBULANCE	
1	PFOOO	6150012691840	19207	12341408	CABLE ASSEMBLY, SPEC.....	1
					UOC:A15, B15, B16, H15, H16	
2	PAOZA	5935001677775	96906	MS27144-1	.CONNECTOR, PLUG, ELEC.....	1
					UOC:A15, B15, B16, H15, H16	
3	PAOZZ	9905010138723	81349	M43436/3-1	.BAND, MARKER.....	2
					UOC:A15, B15, B16, H15, H16	
4	MOOZZ		81349	M23053/6-107-0-7	.INSULATION SLEEVING MAKE FROM INSULATION SLEEVING, P/N M23053/6-107-0, 7 INCHES LONG.....	2
					UOC:A15, B15, B16, H15, H16	
5	PAOZZ	5940001133143	96906	MS20659-103	.TERMINAL, LUG.....	2
					UOC:A15, B15, B16, H15, H16	
6	PAOZZ	5935004626603	96906	MS27142-2	.CONNECTOR, PLUG, ELEC.....	1
					UOC:A15, B15, B16, H15, H16	

END OF FIGURE

1 — 2  
thru  
7



 <b>VIEW A</b>	 <b>VIEW B</b>	 <b>VIEW C</b>	 <b>VIEW D</b>	 <b>VIEW E</b>	 <b>VIEW F</b>
 <b>VIEW G</b>	 <b>VIEW H</b>	 <b>VIEW I</b>	 <b>VIEW J</b>	 <b>VIEW K</b>	 <b>VIEW L</b>

Figure 91. Main Power Cable Assembly, M996, M996A1, M997, M997A1, and M997A2 Ambulance.

SECTION II			TM9-2320-280-24P			
(1)	(2)	(3)	(4)	(5)	(6)	(7)
ITEM NO	SMR CODE	NSN	CAGEC	PART NUMBER	DESCRIPTION AND USABLE ON CODES(UOC)	QTY
					GROUP 0613 HULL OR CHASSIS WIRING HARNESS	
					FIG. 91 MAIN POWER CABLE ASSEMBLY, M996, M996A1, M997, M997A1, AND M997A2 AMBULANCE	
1	PFOOO	6150012695275	19207	12341294	CABLE ASSEMBLY, POWE.....	1
					UOC:A15, B15, B16, H15, H16	
2	PAOZZ	5940001154992	96906	MS20659-110	. TERMINAL, LUG.....	2
					UOC:A15, B15, B16, H15, H16	
3	MOOZZ		81349	M23053/6-104-2-4	. INSULATION SLEEVING MAKE FROM INSULATION SLEEVING, P/N M23053/6-104-2, 4 INCHES LONG.....	2
					UOC:A15, B15, B16, H15, H16	
4	PAOZZ	9905010138723	81349	M43436/3-1	. BAND, MARKER.....	4
					UOC:A15, B15, B16, H15, H16	
5	PAOZZ	5940001152676	96906	MS20659-143	. TERMINAL, LUG.....	1
					UOC:A15, B15, B16, H15, H16	
6	MOOZZ		81349	M23053/6-103-6-3	. INSULATION SLEEVING BLACK, 106 I.D., MAKE FROM INSULATION SLEEVING, P/N M23053/6-103-6, 3 INCHES LONG...	2
					UOC:A15, B15, B16, H15, H16	
7	PAOZZ	5940001141317	96906	MS20659-109	. TERMINAL, LUG.....	1
					UOC:A15, B15, B16, H15, H16	
8	PAOZZ	5310012708189	34623	5593413	NUT #10-32.....	1
					UOC:A15, B15, B16, H15, H16	
9	PAOZZ	5340007247038	96906	MS21333-76	CLAMP, LOOP.....	1
					UOC:A15, B15, B16, H15, H16	
10	PAOZZ	5305001798946	24617	9418346	SCREW, MACHINE #10-32 X 3/4.....	6
					UOC:A15, B15, B16, H15, H16	
11	PAOZZ	5340000502740	96906	MS21333-75	CLAMP, LOOP.....	6
					UOC:A15, B15, B16, H15, H16	
12	PAOZZ	5325012901695	34623	5593535	GROMMET, NONMETALLIC.....	1
					UOC:A15, B15, B16, H15, H16	
13	PAOZZ	5325012897859	28520	2400	GROMMET, NONMETALLIC.....	2
					UOC:A15, B15, B16, H15, H16	
14	PAOZZ	5340006899514	96906	MS21333-70	CLAMP, LOOP.....	2
					UOC:A15, B15, B16, H15, H16	

END OF FIGURE

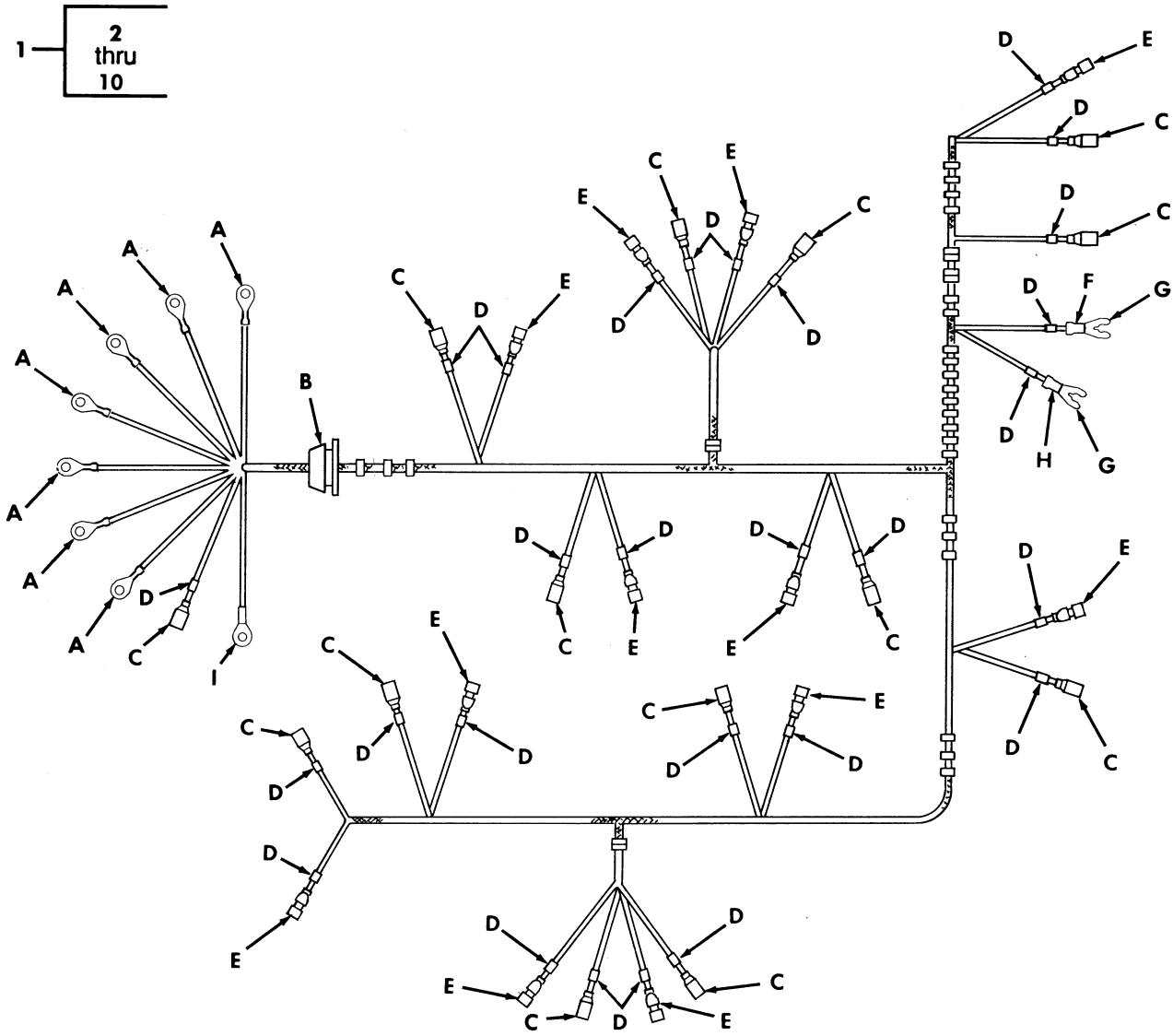

1 — 2 thru 10







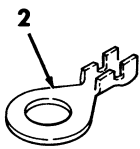

 <p><b>VIEW A</b></p>	 <p><b>VIEW B</b></p>	 <p><b>VIEW C</b></p>	 <p><b>VIEW D</b></p>	 <p><b>VIEW E</b></p>
 <p><b>VIEW F</b></p>	 <p><b>VIEW G</b></p>	 <p><b>VIEW H</b></p>	 <p><b>VIEW I</b></p>	

Figure 92. Interior Lighting Harness Assembly, M996, M996A1, M997, M997A1, and M997A2 Ambulance (Sheet 1 of 2).

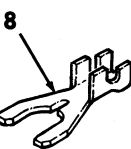

<p><b>VIEW J</b></p>	<p><b>VIEW K</b></p>	<p><b>VIEW L</b></p>	<p><b>VIEW M</b></p>	<p><b>VIEW N</b></p>
<p><b>VIEW O</b></p>	<p><b>VIEW P</b></p>	<p><b>VIEW Q</b></p>	<p><b>VIEW R</b></p>	

Figure 92. Interior Lighting Harness Assembly, M996, M996A1, M997, M997A1, and M997A2 Ambulance (Sheet 2 of 2).

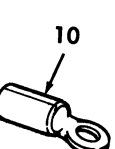
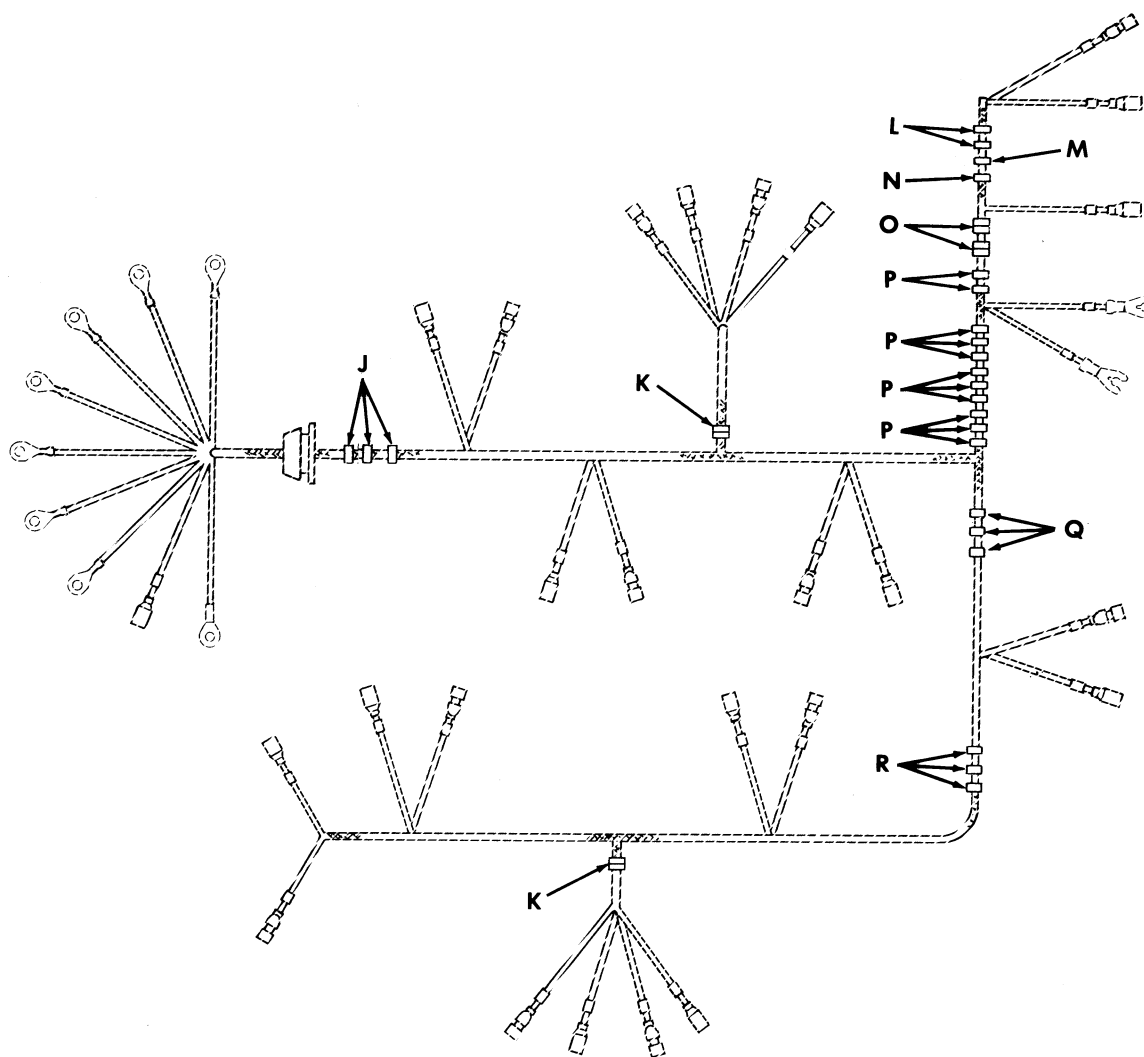
SECTION II			TM9-2320-280-24P			
(1)	(2)	(3)	(4)	(5)	(6)	(7)
ITEM	SMR			PART		
NO	CODE	NSN	CAGEC	NUMBER	DESCRIPTION AND USABLE ON CODES(UOC)	QTY
					GROUP 0613 HULL OR CHASSIS WIRING HARNESS	
					FIG. 92 INTERIOR LIGHTING HARNESS ASSEMBLY, M996, M996A1, M997, M997A1, AND M997A2 AMBULANCE	
1	PFOZZ	6150012695300	19207	12341125	WIRING HARNESS, BRAN.....	1
					UOC:A15, B15, B16, H15, H16	
2	PAOZZ	5940012703700	77060	2973850	. TERMINAL, LUG.....	7
					UOC:A15, B15, B16, H15, H16	
3	PFOZZ		19207	12341125-1	. GROMMET, NONMETALLIC.....	1
					UOC:A15, B15, B16, H15, H16	
4	PAOZZ	5935004626603	96906	MS27142-2	. CONNECTOR, PLUG, ELEC.....	14
					UOC:A15, B15, B16, H15, H16	
5	PAOZZ	9905010138723	81349	M43436/3-1	. BAND, MARKER.....	28
					UOC:A15, B15, B16, H15, H16	
6	PAOZA	5935001677775	96906	MS27144-1	. CONNECTOR, PLUG, ELEC.....	12
					UOC:A15, B15, B16, H15, H16	
7	MOOZZ		81349	M23053/6-107-1-7	. INSULATION SLEEVING RED, 0.375 I.D., MAKE FROM INSULATION SLEEVING, P/N M23053/6-107-1, 7 INCHES LONG....	1
					UOC:A15, B15, B16, H15, H16	
8	PAOZZ		19207	12342022	. TERMINAL, LUG.....	2
					UOC:A15, B15, B16, H15, H16	
9	MOOZZ		81349	M23053/6-107-0-7	. INSULATION SLEEVING BLACK, 0.375 I.D., MAKE FROM INSULATION SLEEVING, P/N M23053/6-107-0, 7 INCHES LONG....	1
					UOC:A15, B15, B16, H15, H16	
10	PAOZZ	5940001071481	96906	MS20659-104	. TERMINAL, LUG.....	1
					UOC:A15, B15, B16, H15, H16	
11	PAOZZ	5305012729042	34623	5593409	SCREW, CAP, HEXAGON H.....	20
					UOC:A15, B15, B16, H15, H16	
12	PAOZZ	5340000572906	96906	MS21333-73	CLAMP, LOOP.....	3
					UOC:A15, B15, B16, H15, H16	
13	PAOZZ	5325002919366	96906	MS35489-11	GROMMET, NONMETALLIC.....	2
					UOC:A15, B15, B16, H15, H16	
14	PAOZZ	5305000593660	96906	MS51958-64	SCREW, MACHINE #10-32 X .62.....	2
					UOC:A15, B15, B16, H15, H16	
15	PAOZZ	5340000572904	96906	MS21333-71	CLAMP, LOOP.....	14
					UOC:A15, B15, B16, H15, H16	
16	PAOZZ	5310012708189	24617	271168	NUT #10-32.....	2
					UOC:A15, B15, B16, H15, H16	
17	PAOZZ	5305012542460	34623	5592840	SCREW, TAPPING, THREA #10-16 X .50...	3
					UOC:A15, B15, B16, H15, H16	
18	PAOZZ	5365012896169	19207	12356795	SPACER, PLATE.....	1
					UOC:A15, B15, B16, H15, H16	
19	PAOZZ	5325012895038	28520	2874	GROMMET, NONMETALLIC.....	2
					UOC:A15, B15, B16, H15, H16	
20	PAOZZ	5340006899514	96906	MS21333-70	CLAMP, LOOP.....	3
					UOC:A15, B15, B16, H15, H16	
21	PAOZZ	5340007647051	96906	MS21333-69	CLAMP, LOOP.....	3
					UOC:A15, B15, B16, H15, H16	

END OF FIGURE



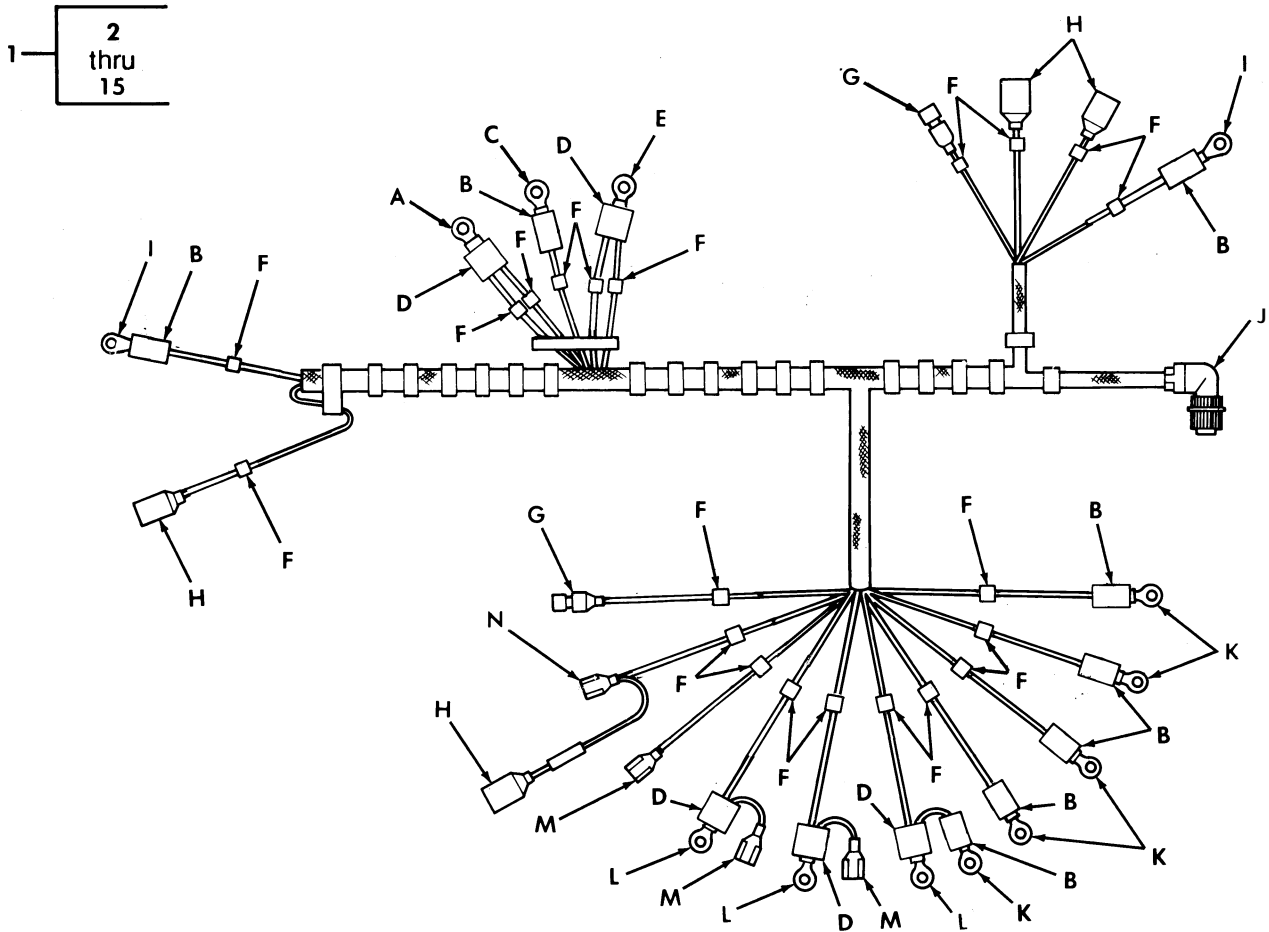















 <b>VIEW A</b>	 <b>VIEW B</b>	 <b>VIEW C</b>	 <b>VIEW D</b>	 <b>VIEW E</b>	 <b>VIEW F</b>
 <b>VIEW G</b>	 <b>VIEW H</b>	 <b>VIEW I</b>	 <b>VIEW J</b>	 <b>VIEW K</b>	 <b>VIEW L</b>
 <b>VIEW M</b>	 <b>VIEW N</b>				

Figure 93. Heating/Vent Harness Assembly, M966 and M996A1 Ambulance (Sheet 1 of 2).

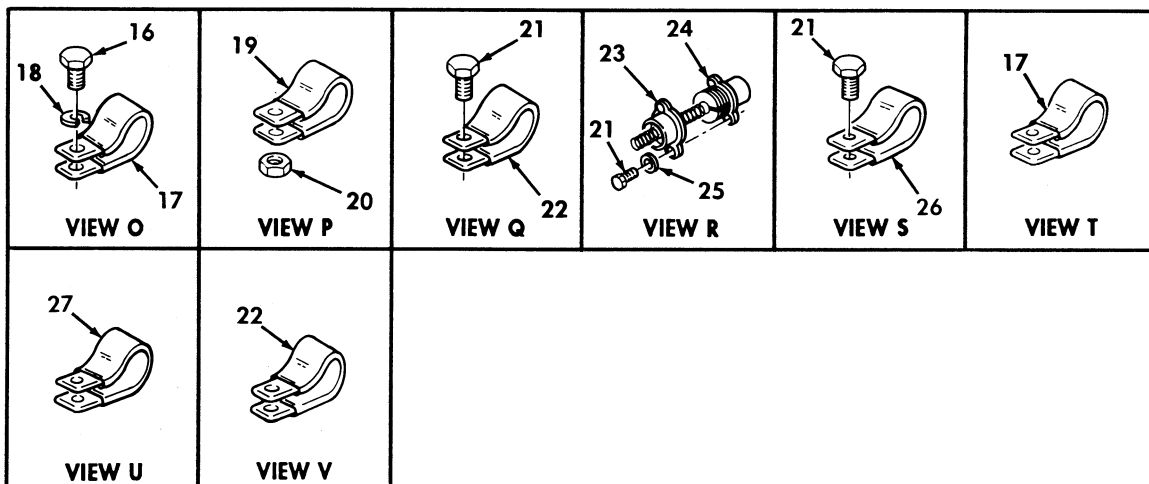
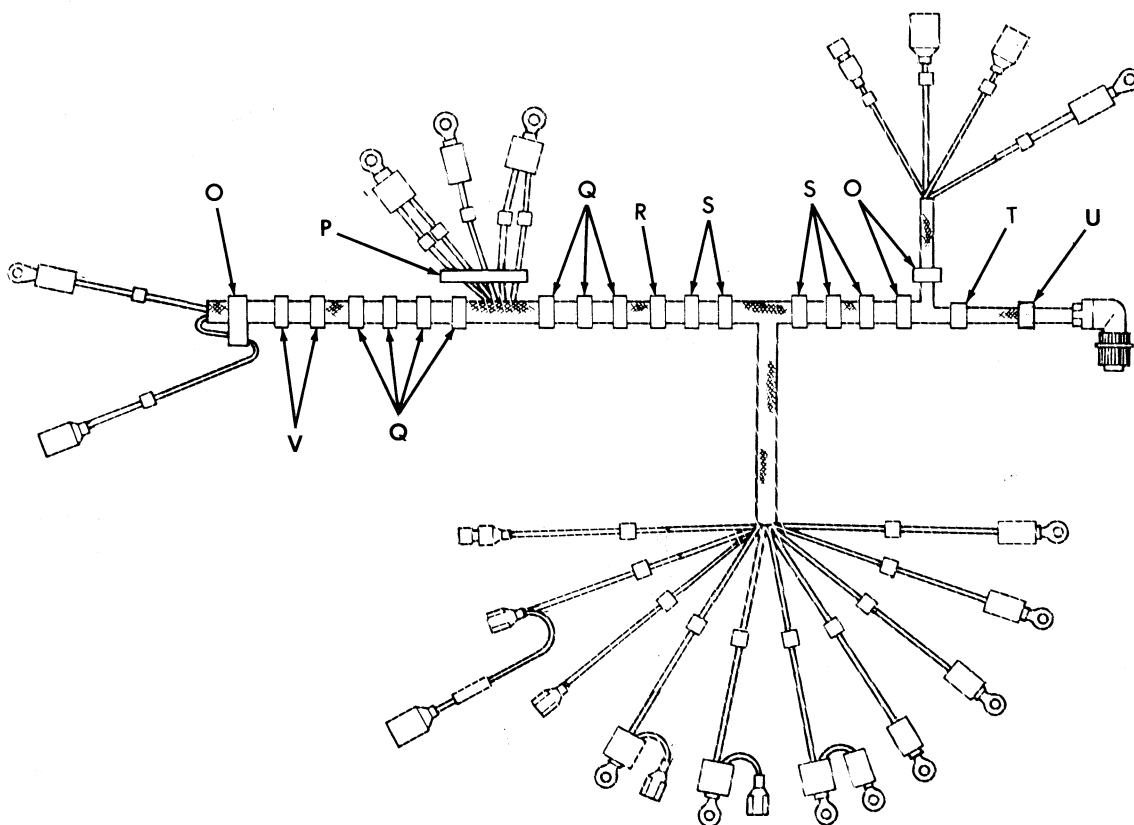

Figure 93. Heating/Vent Harness Assembly, M966 and M996A1 Ambulance (Sheet 2 of 2).

SECTION II			TM9-2320-280-24P			
(1)	(2)	(3)	(4)	(5)	(6)	(7)
ITEM	SMR			PART		
NO	CODE	NSN	CAGEC	NUMBER	DESCRIPTION AND USABLE ON CODES(UOC)	QTY
					GROUP 0613 HULL OR CHASSIS WIRING HARNESS	
					FIG. 93 HEATING/VENT HARNESS ASSEMBLY,M996 AND M996A1 AMBULANCE	
1	PFOOO	6150012691897	19207	12341458	WIRING HARNESS.....	1
					UOC:B16,H16	
2	PAOZZ	5940013417689	77060	12004436	. TERMINAL,LUG.....	1
					UOC:B16,H16	
3	MOOZZ		81349	M23053/4-302-0-.75	. INSULATION SLEEVING BLACK,(14 AWG),MAKE FROM INSULATION SLEEVING,P/N ,M23053/4-302-0,0.75 INCHES LONG	8
					UOC:B16,H16	
4	PAOZZ	5940012703701	77060	2965718	. TERMINAL,LUG.....	1
					UOC:B16,H16	
5	MOOZZ		81349	M23053/4-303-0-.75	. INSULATION SLEEVING BLACK,(14-AWG) MAKE FROM INSULATION SLEEVING,P/N M23053/4-303-0,0.75 INCHES LONG	5
					UOC:B16,H16	
6	PAOZZ	5940012703700	77060	2973850	. TERMINAL,LUG.....	1
					UOC:B16,H16	
7	PAOZZ	9905010138723	81349	M43436/3-1	. BAND,MARKER.....	21
					UOC:B16,H16	
8	PAOZA	5935001677775	96906	MS27144-1	. CONNECTOR,PLUG,ELEC.....	2
					UOC:B16,H16	
9	PAOZZ	5935004626603	96906	MS27142-2	. CONNECTOR,PLUG,ELEC.....	4
					UOC:B16,H16	
10	PAOZZ	5940007056703	56501	TG3	. TERMINAL,LUG.....	2
					UOC:B16,H16	
11	PAOZA	5935008064183	96906	MS3108R18-11S	. CONNECTOR,PLUG,ELEC.....	1
					UOC:B16,H16	
12	PAOZZ	5940001133143	96906	MS20659-103	. TERMINAL,LUG.....	5
					UOC:B16,H16	
13	PAOZZ	5940001130954	96906	MS20659-165	. TERMINAL,LUG.....	3
					UOC:B16,H16	
14	PAOZZ	5940014400097	98853	361130-EA02	. TERMINAL,QUICK DISC.....	3
					UOC:B16,H16	
15	PAOZZ	5940014364561	98853	361230-D	. TERMINAL,QUICK DISC.....	1
					UOC:B15,B16,H16	
16	PAOZZ	5305000680502	96906	MS90725-6	SCREW,CAP,HEXAGON H 1/4-20 X .75...	3
					UOC:B16,H16	
17	PAOZZ	5340008546729	96906	MS21333-103	CLAMP,LOOP.....	4
					UOC:B16,H16	
18	PAOZZ	5310005825965	96906	MS35338-44	WASHER,LOCK 1/4.....	3
					UOC:B16,H16	
19	PAOZZ	5340000572904	96906	MS21333-71	CLAMP,LOOP.....	1
					UOC:B16,H16	
20	PAOZZ	5310012708189	34623	5593413	NUT #10-32.....	1
					UOC:B16,H16	
21	PAOZZ	5305001798946	24617	9418346	SCREW,MACHINE #10-32 X .75.....	14
					UOC:B16,H16	
22	PAOZZ	5340009226300	96906	MS21333-77	CLAMP,LOOP.....	9

SECTION II			TM9-2320-280-24P			
(1)	(2)	(3)	(4)	(5)	(6)	(7)
ITEM	SMR			PART		
NO	CODE	NSN	CAGEC	NUMBER	DESCRIPTION AND USABLE ON CODES(UC)	QTY
23	PAOZZ	2590004543620	34623	809223	UOC:B16,H16 RETAINER,ASSEMBLY.....	1
24	PAOZZ	5365012728435	19207	12341231-2	UOC:B16,H16 BUSHING,NONMETALLIC.....	1
25	PAOZZ	5310000145850	96906	MS27183-42	UOC:B16,H16 WASHER,FLAT 7/32.....	2
26	PAOZZ	5340000913790	96906	MS21333-72	UOC:B16,H16 CLAMP,LOOP.....	5
27	PAOZZ	5340000886655	96906	MS21333-101	UOC:B16,H16 CLAMP,LOOP.....	1

END OF FIGURE

Section II.

TM 9-2320-280-24P-1

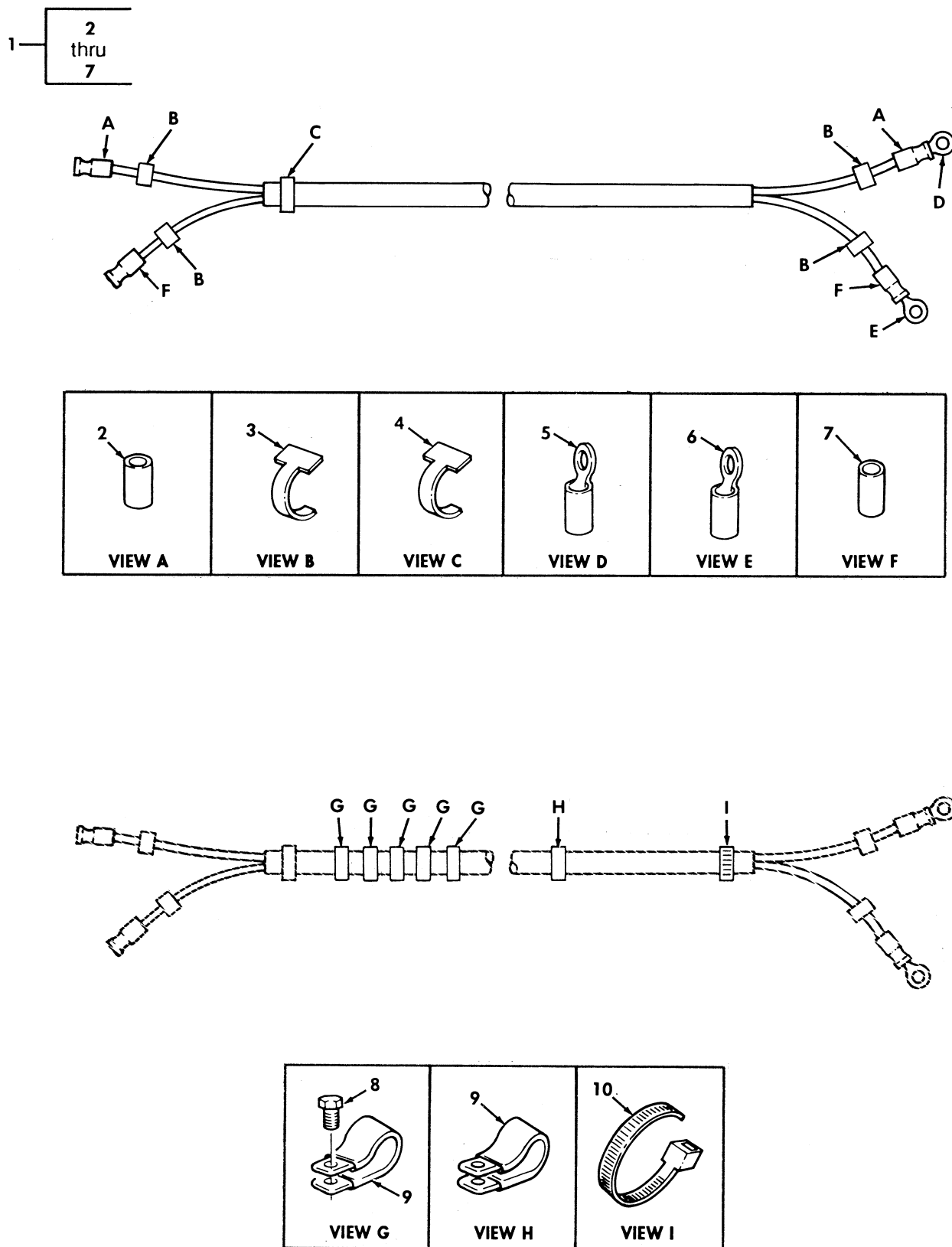
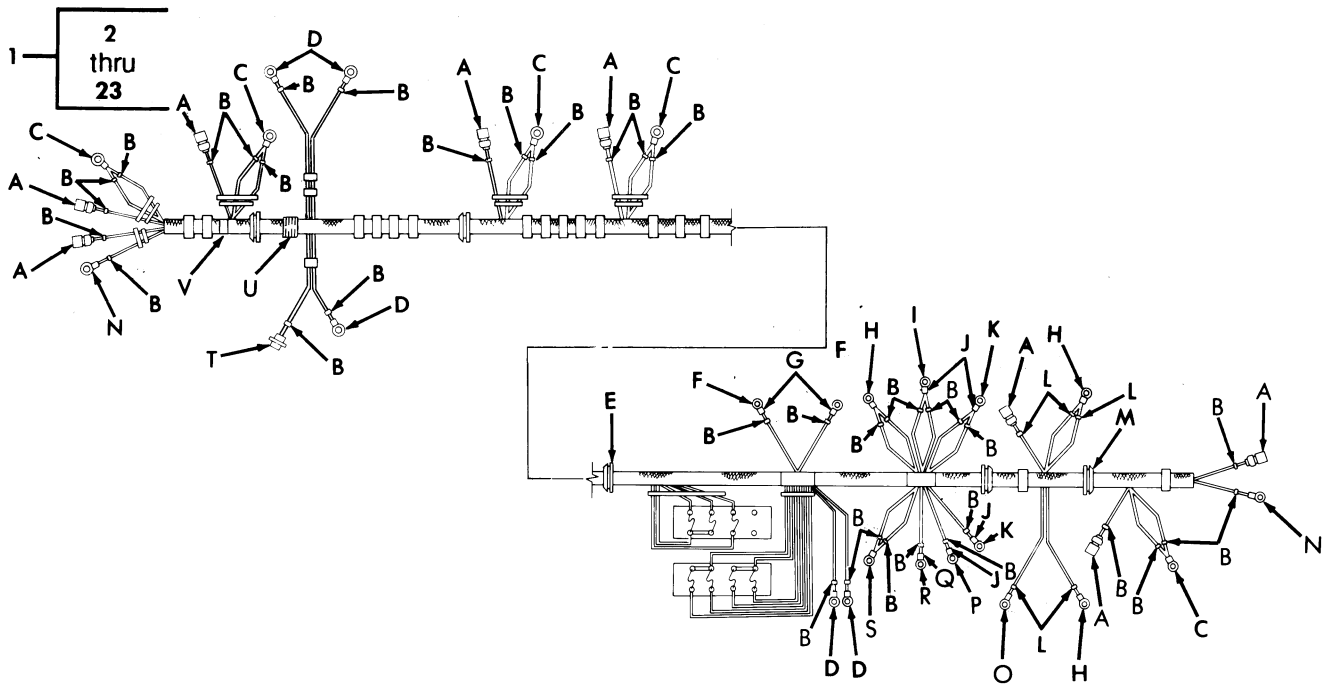

Figure 94. Aspirator/Resuscitator Cable Assembly, M996, M996A1, M997, M997A1, and M997A2 Ambulance.

SECTION II			TM9-2320-280-24P			
(1)	(2)	(3)	(4)	(5)	(6)	(7)
ITEM	SMR			PART		
NO	CODE	NSN	CAGEC	NUMBER	DESCRIPTION AND USABLE ON CODES(UOC)	QTY
					GROUP 0613 HULL OR CHASSIS WIRING HARNESS	
					FIG. 94 ASPIRATOR/RESUSCITATOR CABLE ASSEMBLY, M996, M996A1, M997, M997A1, AND M997A2 AMBULANCE	
1	PFOOO	6150012695299	19207	12341293	WIRING HARNESS.....	1
					UOC:A15,B15,B16,H15,H16	
2	MOOZZ		81349	M23053/15-112-2-.75	.INSULATION SLEEVING RED,6 AWG, MAKE FROM INSULATION SLEEVING,P/N M23053/15-112-2,0.75 INCHES LONG....	2
					UOC:A15,B15,B16,H15,H16	
3	PAOZZ	9905008933570	81349	M43436/1-3	.BAND,MARKER.....	4
					UOC:A15,B15,B16,H15,H16	
4	PAOZZ	9905009457637	81349	M43436/1-4	.BAND,MARKER.....	1
					UOC:A15,B15,B16,H15,H16	
5	PAOZZ	5940001152676	96906	MS20659-143	.TERMINAL,LUG 6 AWG,3/8 STUD.....	1
					UOC:A15,B15,B16,H15,H16	
6	PAOZZ	5940001154992	96906	MS20659-110	.TERMINAL,LUG.....	1
					UOC:A15,B15,B16,H15,H16	
7	MOOZZ		81349	M23053/15-112-0-.75	.INSULATION SLEEVING BLACK,6 AWG, MAKE FROM HEATSHRINK,P/N M23053/15-112-0,0.75 INCHES LONG.....	2
					UOC:A15,B15,B16,H15,H16	
8	PAOZZ	5305001798946	24617	9418346	SCREW,MACHINE #10-32 X .75.....	5
					UOC:A15,B15,B16,H15,H16	
9	PAOZZ	5340000502740	96906	MS21333-75	CLAMP,LOOP.....	6
					UOC:A15,B15,B16,H15,H16	
10	PAOZZ	5975009856630	96906	MS3367-3-0	STRAP,TIEDOWN,ELECT.....	1
					UOC:A15,B15,B16,H15,H16	

END OF FIGURE





















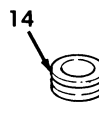

 <b>VIEW A</b>	 <b>VIEW B</b>	 <b>VIEW C</b>	 <b>VIEW D</b>	 <b>VIEW E</b>	 <b>VIEW F</b>
 <b>VIEW G</b>	 <b>VIEW H</b>	 <b>VIEW I</b>	 <b>VIEW J</b>	 <b>VIEW K</b>	 <b>VIEW L</b>
 <b>VIEW M</b>	 <b>VIEW N</b>	 <b>VIEW O</b>	 <b>VIEW P</b>	 <b>VIEW Q</b>	 <b>VIEW R</b>
 <b>VIEW S</b>	 <b>VIEW T</b>	 <b>VIEW U</b>	 <b>VIEW V</b>		

Figure 95. NBC Wiring Harness, M997, M997A1, and M997A2 Ambulance (Sheet 1 of 2).

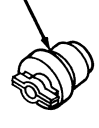
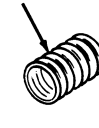

<p><b>VIEW W</b></p>	<p><b>VIEW X</b></p>	<p><b>VIEW Y</b></p>	<p><b>VIEW Z</b></p>	<p><b>VIEW AA</b></p>	<p><b>VIEW AB</b></p>	<p><b>VIEW AC</b></p>
<p><b>VIEW AD</b></p>	<p><b>VIEW AE</b></p>	<p><b>VIEW AF</b></p>	<p><b>VIEW AG</b></p>	<p><b>VIEW AH</b></p>	<p><b>VIEW AI</b></p>	<p><b>VIEW AJ</b></p>
<p><b>VIEW AK</b></p>						

Figure 95. NBC Wiring Harness, M997, M997A1, and M997A2 Ambulance (Sheet 2 of 2).

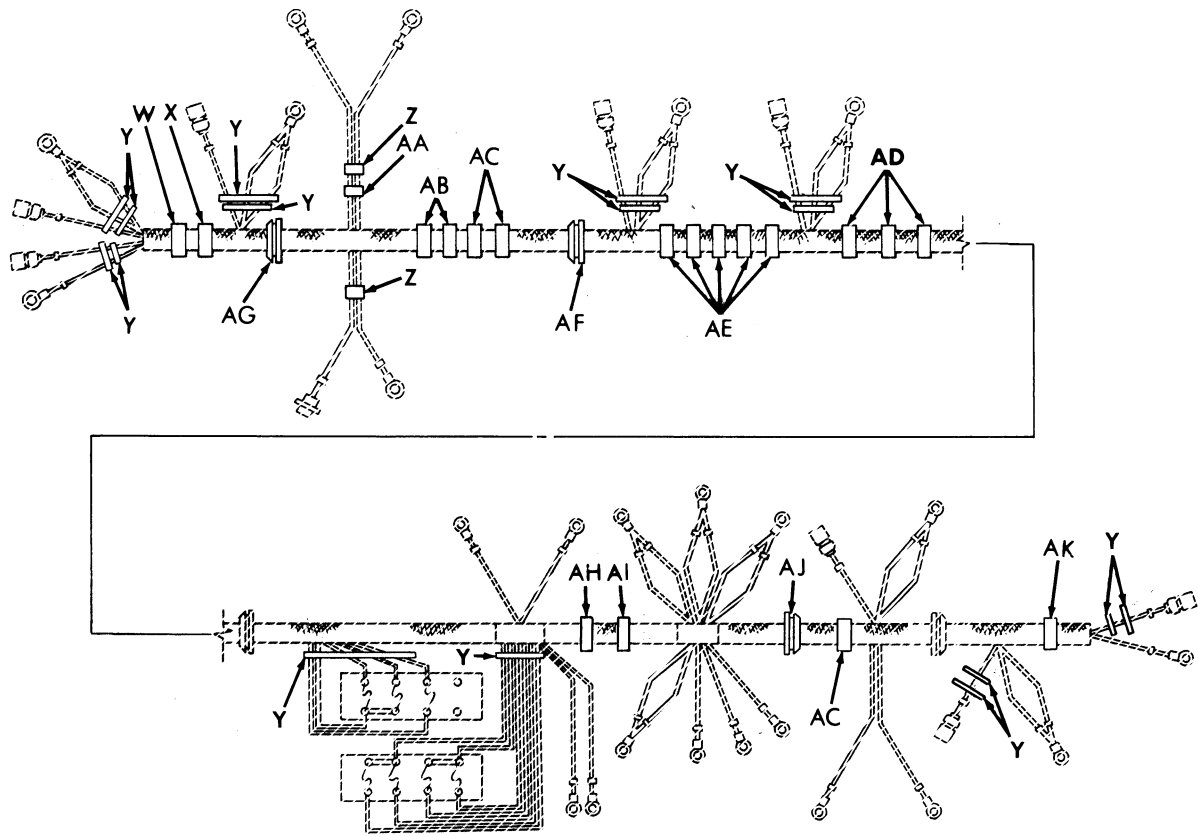

SECTION II			TM9-2320-280-24P			
(1)	(2)	(3)	(4)	(5)	(6)	(7)
ITEM	SMR			PART		
NO	CODE	NSN	CAGEC	NUMBER	DESCRIPTION AND USABLE ON CODES(UOC)	QTY
					GROUP 0613 HULL OR CHASSIS WIRING HARNESS	
					FIG. 95 NBC WIRING HARNESS,M997, M997A1,AND M997A2 AMBULANCE	
1	PFOZZ	6150012695298	19207	12341207	WIRING HARNESS.....	1
					UOC:A15,B15,H15	
2	PAOZA	5935001677775	96906	MS27144-1	.CONNECTOR,PLUG,ELEC.....	8
					UOC:A15,B15,H15	
3	PAOZZ	9905010138723	81349	M43436/3-1	.BAND,MARKER.....	37
					UOC:A15,B15,H15	
4	PAOZZ	5940014439580	98853	100828-HN37	.TERMINAL,LUG.....	5
					UOC:A15,B15,H15	
5	PAOZZ	5940001133143	96906	MS20659-103	.TERMINAL,LUG.....	5
					UOC:A15,B15,H15	
6	PAOZZ	5325014775348	34623	5597277	.GROMMET,METALLIC.....	1
					UOC:A15,B15,H15	
7	PAOZZ	5940012703700	77060	2973850	.TERMINAL,LUG.....	2
					UOC:A15,B15,H15	
8	MOOZZ		81349	M23053/4-302-2-2	.INSULATION SLEEVING MAKE FROM INSULATION,P/N M23053/4-302-2,2 INCHES LONG.....	2
					UOC:A15,B15,H15	
9	PAOZZ	5940001141300	96906	MS20659-105	.TERMINAL,LUG.....	3
					UOC:A15,B15,H15	
10	PAOZZ	5940001139819	96906	MS20659-106	.TERMINAL,LUG.....	1
					UOC:A15,B15,H15	
11	MOOZZ		81349	M23053/4-304-2-4	.TUBING,HEATSHRINK MAKE FROM INSULATION, P/N M23053/4-304-2,4 INCHES LONG.....	4
					UOC:A15,B15,H15	
12	PAOZZ	5940001152674	96906	MS20659-108	.TERMINAL,LUG.....	2
					UOC:A15,B15,H15	
13	MOOZZ		81349	M23053/4-203-2-3	.INSULATION SLEEVING RED,MAKE FROM HEATSHRING,P/N M23053/4-203-2,3 INCHES LONG.....	5
					UOC:A15,B15,H15	
14	PAOZZ		34623	5597208	.GROMMET,NONMETALLIC.....	1
					UOC:A15,B15,H15	
15	PAOZZ	5940012703702	77060	2984172	.TERMINAL,LUG 1/4 X 1-14 AWG.....	2
					UOC:A15,B15,H15	
16	PAOZZ	5940001141314	96906	MS20659-129	.TERMINAL,LUG.....	1
					UOC:A15,B15,H15	
17	PAOZZ	5940001133145	96906	MS20659-163	.TERMINAL,LUG.....	1
					UOC:A15,B15,H15	
18	MOOZZ		81349	M23053/4-303-2-3	.INSULATION SLEEVING RED,MAKE FROM INSULATION,P/N M23053/4-303-2,3 INCHES LONG.....	1
					UOC:A15,B15,H15	
19	PAOZZ	5940012698396	77060	6288634-L	.TERMINAL,LUG.....	1
					UOC:A15,B15,H15	
20	PAOZZ	5940001139825	96906	MS20659-141	.TERMINAL,LUG.....	1

SECTION II			TM9-2320-280-24P			
(1)	(2)	(3)	(4)	(5)	(6)	(7)
ITEM NO	SMR CODE	NSN	CAGEC	PART NUMBER	DESCRIPTION AND USABLE ON CODES(UOC)	QTY
21	PAOZA	5935011470148	96906	MS3456W12-5S	UOC:A15,B15,H15 .CONNECTOR,PLUG,ELEC.....	1
22	MOOZZ		19207	12339351-3	UOC:A15,B15,H15 .CONDUIT MAKE FROM TUBING, NONMETALLIC,P/N 12420924-004,46 INCHES LONG.....	1
23	MOOZZ		81349	M23053/4-202-2-2	UOC:A15,B15,H15 .INSULATION,SLEEVING RED,MAKE FROM INSULATION,P/N M23053/4-202-2,2 INCHES LONG.....	1
24	PAOZZ	5340006899514	96906	MS21333-70	UOC:A15,B15,H15 CLAMP,LOOP.....	1
25	PAOZZ	5305009897435	96906	MS35207-264	UOC:A15,B15,H15 SCREW,MACHINE #10-32 X .62.....	2
26	PAOZZ	5340000572904	96906	MS21333-71	UOC:A15,B15,H15 CLAMP,LOOP.....	1
27	PAOZZ	5975009856630	96906	MS3367-3-0	UOC:A15,B15,H15 .STRAP,TIEDOWN,ELECT.....	16
28	PAOZZ	5340008437825	96906	MS21333-68	UOC:A15,B15,H15 CLAMP,LOOP.....	2
29	PAOZZ	5305012729042	34623	5593409	UOC:A15,B15,H15 SCREW,CAP,HEXAGON H #10-32 X .75...	6
30	PAOZZ	5325012743317	96906	MS35489-39X	UOC:A15,B15,H15 GROMMET, NONMETALLIC.....	1
31	PAOZZ	5340009226300	96906	MS21333-77	UOC:A15,B15,H15 CLAMP,LOOP.....	6
32	PAOZZ	5310001249265	24617	271169	UOC:A15,B15,H15 NUT,PLAIN,ASSEMBLED #10-32.....	5
33	PAOZZ	5340009899222	96906	MS21333-74	UOC:A15,B15,H15 CLAMP,LOOP.....	3
34	PAOZZ	5305012113786	24617	167163	UOC:A15,B15,H15 SCREW,TAPPING #10-32 X .50.....	3
35	PAOZZ	5340000572906	96906	MS21333-73	UOC:A15,B15,H15 CLAMP,LOOP.....	5
36	PAOZZ	5305001798946	24617	9418346	UOC:A15,B15,H15 SCREW,MACHINE #10-32 X .63.....	5
37	PFOZZ	2590004543620	19207	809223	UOC:A15,B15,H15 RETAINER,ASSEMBLY.....	2
38	PAOZZ	5365012744675	34623	5995488	UOC:A15,B15,H15 BUSHING, NONMETALLIC.....	1
39	PAOZZ	5310000145850	96906	MS27183-42	UOC:A15,B15,H15 WASHER,FLAT #10.....	2
40	PAOZZ	5310011520598	24617	271172	UOC:A15,B15,H15 NUT,SELF-LOCKING,AS 1/4-20.....	2
41	PAOZZ	5365012728435	19207	12341231-2	UOC:A15,B15,H15 BUSHING, NONMETALLIC.....	1
42	PAOZZ	5305002253843	80204	B1821BH025C100N	UOC:A15,B15,H15 SCREW,CAP,HEXAGON H 1/4-20 X 1.00..	2
43	PAOZZ	5305000593660	96906	MS51958-64	UOC:A15,B15,H15 SCREW,MACHINE #10-32 X .62.....	2
44	PFOZZ	5340007247038	96906	MS21333-76	UOC:A15,B15,H15 CLAMP,LOOP.....	1

SECTION II			TM9-2320-280-24P			
(1)	(2)	(3)	(4)	(5)	(6)	(7)
ITEM	SMR			PART		
NO	CODE	NSN	CAGEC	NUMBER	DESCRIPTION AND USABLE ON CODES(UC)	QTY
45	PFOZZ	5325012896196	34623	12341627	GROMMET, NONMETALLIC.....	1
					UOC:A15, B15, H15	
46	PAOZZ	5340007647051	96906	MS21333-69	CLAMP, LOOP.....	1
					UOC:A15, B15, H15	

END OF FIGURE

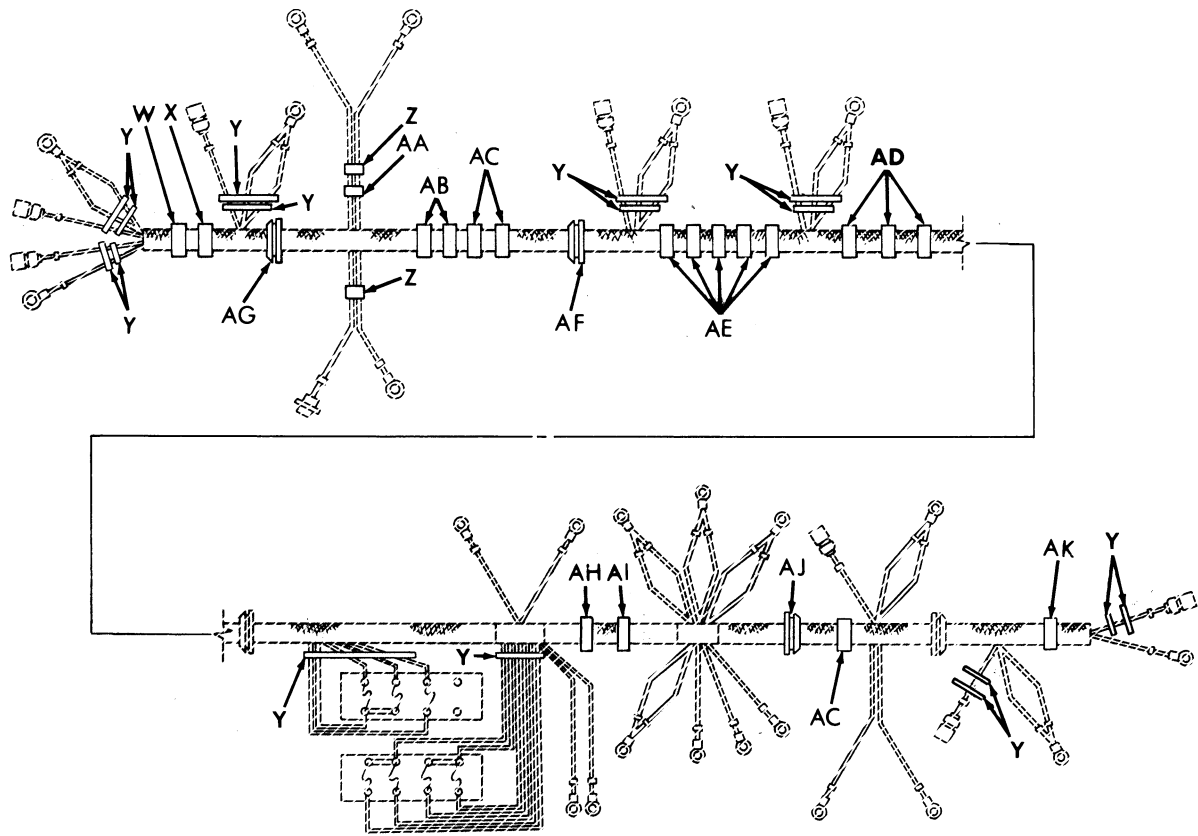

<p><b>VIEW W</b></p>	<p><b>VIEW X</b></p>	<p><b>VIEW Y</b></p>	<p><b>VIEW Z</b></p>	<p><b>VIEW AA</b></p>	<p><b>VIEW AB</b></p>	<p><b>VIEW AC</b></p>
<p><b>VIEW AD</b></p>	<p><b>VIEW AE</b></p>	<p><b>VIEW AF</b></p>	<p><b>VIEW AG</b></p>	<p><b>VIEW AH</b></p>	<p><b>VIEW AI</b></p>	<p><b>VIEW AJ</b></p>
<p><b>VIEW AK</b></p>						

Figure 95. NBC Wiring Harness, M997, M997A1, and M997A2 Ambulance (Sheet 1 of 2).

1 — 2  
thru  
17

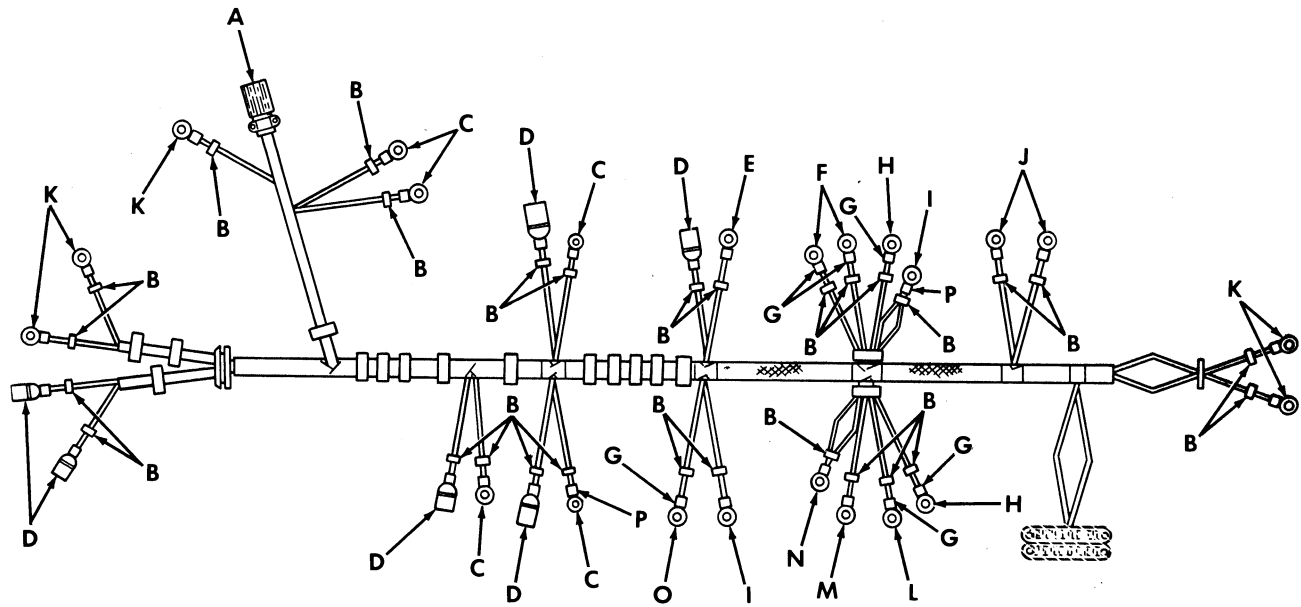







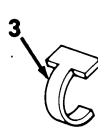

 <p><b>VIEW A</b></p>	 <p><b>VIEW B</b></p>	 <p><b>VIEW C</b></p>	 <p><b>VIEW D</b></p>	 <p><b>VIEW E</b></p>	 <p><b>VIEW F</b></p>
 <p><b>VIEW G</b></p>	 <p><b>VIEW H</b></p>	 <p><b>VIEW I</b></p>	 <p><b>VIEW J</b></p>	 <p><b>VIEW K</b></p>	 <p><b>VIEW L</b></p>
 <p><b>VIEW M</b></p>	 <p><b>VIEW N</b></p>	 <p><b>VIEW O</b></p>	 <p><b>VIEW P</b></p>		

Figure 96. NBC Wiring Harness, M996 and M996A1 Ambulance (Sheet 1 of 2).



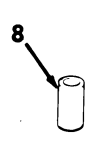

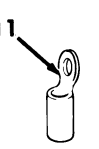
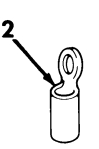
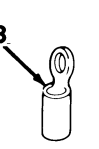

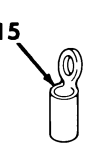
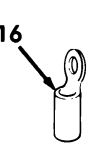
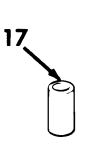
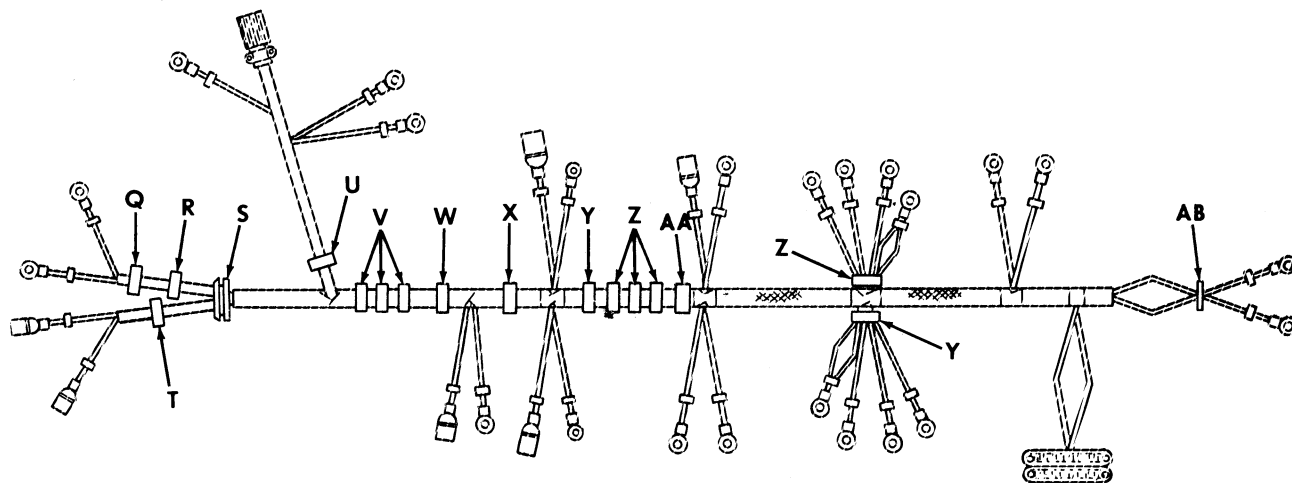

 <p><b>VIEW Q</b></p>	 <p><b>VIEW R</b></p>	 <p><b>VIEW S</b></p>	 <p><b>VIEW T</b></p>	 <p><b>VIEW U</b></p>	 <p><b>VIEW V</b></p>
 <p><b>VIEW W</b></p>	 <p><b>VIEW X</b></p>	 <p><b>VIEW Y</b></p>	 <p><b>VIEW Z</b></p>	 <p><b>VIEW AA</b></p>	 <p><b>VIEW AB</b></p>

Figure 96. NBC Wiring Harness, M996 and M996A1 Ambulance (Sheet 2 of 2).

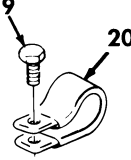
SECTION II			TM9-2320-280-24P			
(1)	(2)	(3)	(4)	(5)	(6)	(7)
ITEM	SMR			PART		
NO	CODE	NSN	CAGEC	NUMBER	DESCRIPTION AND USABLE ON CODES(UOC)	QTY
					GROUP 0613 HULL OR CHASIS WIRING HARNESS	
					FIG. 96 NBC WIRING HARNESS,M996 AND M996A1 AMBULANCE	
1	PFOOO	6150012853901	34623	5597600	WIRING HARNESS.....	1
					UOC:B16,H16	
2	PAOZA	5935011470148	96906	MS3456W12-5S	.CONNECTOR,PLUG,ELEC.....	1
					UOC:B16,H16	
3	PAOZZ	9905010138723	81349	M43436/3-1	.BAND,MARKER.....	29
					UOC:B16,H16	
4	PAOZZ	5940012703702	77066	2984172	.TERMINAL,LUG.....	5
					UOC:B16,H16	
5	PAOZA	5935001677775	96906	MS27144-1	.CONNECTOR,PLUG,ELEC.....	6
					UOC:B16,H16	
6	PAOZZ	5940001071481	96906	MS20659-104	.TERMINAL,LUG.....	1
					UOC:B16,H16	
7	PAOZZ	5940001139819	96906	MS20659-106	.TERMINAL,LUG.....	2
					UOC:B16,H16	
8	MOOZZ		81349	M23053/4-303-2-3	.INSULATION SLEEVING MAKE FROM INSULATION,P/N M23053/4-303-2,3 INCHES LONG.....	6
					UOC:B16,H16	
9	PAOZZ	5940001133145	96906	MS20659-163	.TERMINAL,LUG.....	2
					UOC:B16,H16	
10	PAOZZ	5940001141300	96906	MS20659-105	.TERMINAL,LUG.....	2
					UOC:B16,H16	
11	PAOZZ	5940012703700	77060	2973850	.TERMINAL,LUG.....	2
					UOC:B16,H16	
12	PAOZZ	5940001133143	96906	MS20659-103	.TERMINAL,LUG.....	5
					UOC:B16,H16	
13	PAOZZ	5940001152674	96906	MS20659-108	.TERMINAL,LUG.....	1
					UOC:B16,H16	
14	PAOZZ	5940012895955	77066	2984576	.TERMINAL,LUG.....	1
					UOC:B16,H16	
15	PAOZZ	5940001139825	96906	MS20659-141	.TERMINAL,LUG.....	1
					UOC:B16,H16	
16	PAOZZ	5940001141314	96906	MS20659-129	.TERMINAL,LUG.....	1
					UOC:B16,H16	
17	MOOZZ		81349	M23053/4-303-0-3	.INSULATION SLEEVING MAKE FROM INSULATION,P/N M23053/4-303-0,3 INCHES LONG.....	17
					UOC:B16,H16	
18	PAOZZ	5325001850004	96906	MS35489-40	GROMMET,NONMETALLIC.....	1
					UOC:B16,H16	
19	PAOZZ	5305009931848	96906	MS35207-265	SCREW,MACHINE #10-32 X .75.....	16
					UOC:B16,H16	
20	PAOZZ	5340008437825	96906	MS21333-68	CLAMP,LOOP.....	1
					UOC:B16,H16	
21	PAOZZ	5325002766051	81205	BACG20AF8H1	GROMMET,NONMETALLIC.....	1
					UOC:B16,H16	
22	PAOZZ	5340008091492	81348	CMDX2-3PT573036	CLAMP,LOOP.....	1

SECTION II			TM9-2320-280-24P			
(1)	(2)	(3)	(4)	(5)	(6)	(7)
ITEM	SMR			PART		
NO	CODE	NSN	CAGEC	NUMBER	DESCRIPTION AND USABLE ON CODES (UOC)	QTY
23	PAOZZ	5340008546729	96906	MS21333-103	UOC: B16, H16 CLAMP, LOOP.....	1
24	PAOZZ	5340000572904	96906	MS21333-71	UOC: B16, H16 CLAMP, LOOP.....	3
25	PAOZZ	5340000913790	96906	MS21333-72	UOC: B16, H16 CLAMP, LOOP.....	1
26	PAOZZ	5340009848540	96906	MS21333-102	UOC: B16, H16 CLAMP, LOOP.....	1
27	PAOZZ	5340000502740	96906	MS21333-75	UOC: B16, H16 CLAMP, LOOP.....	2
28	PAOZZ	5340009226300	96906	MS21333-77	UOC: B16, H16 CLAMP, LOOP.....	4
29	PAOZZ	5310000145850	96906	MS27183-42	UOC: B16, H16 WASHER, FLAT #10.....	2
30	PAOZZ	2590004543620	34623	809223	UOC: B16, H16 RETAINER, ASSEMBLY.....	1
31	PAOZZ	5365012729275	19207	12341231-4	UOC: B16, H16 BUSHING, NONMETALLIC.....	1
32	PAOZZ	5975009856630	96906	MS3367-3-0	UOC: B16, H16 STRAP, TIEDOWN, ELECT.....	1

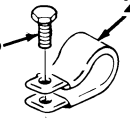
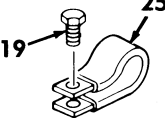
END OF FIGURE

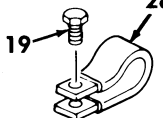
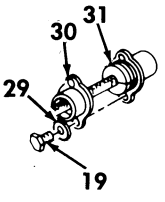
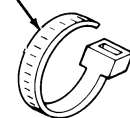

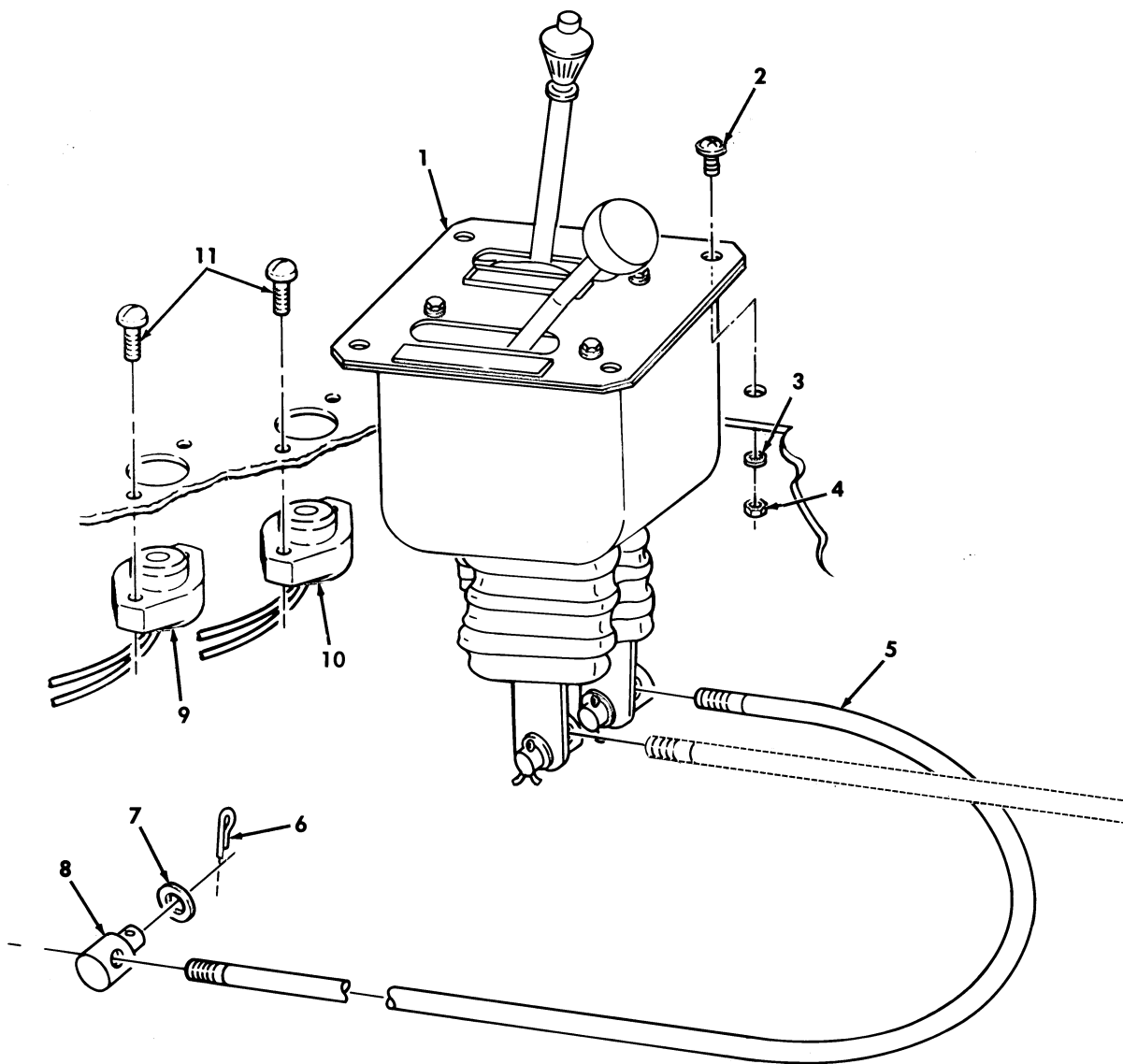

Figure 97. Transmission and Transfer Control Assembly and Shift Rod.

SECTION II			TM9-2320-280-24P			
(1)	(2)	(3)	(4)	(5)	(6)	(7)
ITEM	SMR			PART		
NO	CODE	NSN	CAGEC	NUMBER	DESCRIPTION AND USABLE ON CODES(UOC)	QTY
GROUP 07 TRANSMISSION						
0705 TRANSMISSION SHIFTING						
COMPONENTS						
FIG. 97 TRANSMISSION AND TRANSFER						
CONTROL ASSEMBLY AND SHIFT ROD						
1	PAOOO	2520012047699	19207	12338440-2	CONTROL ASSEMBLY, TR.....	1
					UOC:A15,A20,B16,H15,H16,H20	
1	PAOOO	2520011845501	19207	12338440-1	CONTROL ASSEMBLY, GA.....	1
					UOC:AVY,A11,A13,A14,A24,A25,A26,A27, B17,B18,HVY,H11,H13,H14,H17,H18,H21, H24,H25,H26,H27,H28,MMM	
2	PAOZZ	5305009881724	96906	MS35206-280	SCREW,MACHINE 1/4-20 X 7/8.....	4
					UOC:AVY,A11,A13,A14,A15,A20,A24,A25, A26,A27,B16,B17,B18,HVY,H11,H13,H14, H15,H16,H17,H18,H20,H21,H24,H25,H26, H27,H28,MMM	
3	PAOZZ	5310011023270	24617	2436161	WASHER,FLAT 1/4.....	4
4	PAOZZ	5310000614650	96906	MS51943-31	NUT,SELF-LOCKING,HE 1/4-20.....	4
5	PAOZZ	5306011946433	34623	5583606	BOLT,HOOK.....	1
					UOC:AVY,A11,A13,A14,A15,A20,A24,A25, A26,A27,B16,B17,B18,HVY,H11,H13,H14, H15,H16,H17,H18,H20,H21,H24,H25,H26, H27,H28,MMM	
6	PAOZZ	5315008423044	14351	X601	PIN,COTTER 3/32 X 3/4.....	1
					UOC:AVY,A11,A13,A14,A15,A20,A24,A25, A26,A27,B16,B17,B18,HVY,H11,H13,H14, H15,H16,H17,H18,H20,H21,H24,H25,H26, H27,H28,MMM	
7	PAOZZ	5310012057923	34623	5593213	WASHER,FLAT 3/8.....	1
					UOC:AVY,A11,A13,A14,A15,A20,A24,A25, A26,A27,B16,B17,B18,HVY,H11,H13,H14, H15,H16,H17,H18,H20,H21,H24,H25,H26, H27,H28,MMM	
8	PAOZZ	2520012491434	34623	5593661	TRUNNION,SHIFT CONT.....	1
					UOC:AVY,A11,A13,A14,A15,A20,A24,A25, A26,A27,B16,B17,B18,HVY,H11,H13,H14, H15,H16,H17,H18,H20,H21,H24,H25,H26, H27,H28,MMM	
9	PAOZZ	6220013625211	34623	12342788	LIGHT,INDICATOR TRANSFER.....	1
					UOC:AVY,A11,A13,A14,A15,A20,A24,A25, A26,A27,B16,B17,B18,HVY	
9	PAOZZ	6220014139828	19207	12460092-1	LIGHT,INDICATOR..TRANSFER.....	1
					UOC:BVY,B15,B20,B24,B25,C17,NNN	
10	PAOZZ	6220014126420	9C234	12460092-2	LIGHT,INDICATOR TRANSMISSION.....	1
					UOC:BVY,B15,B20,B24,B25,C17,NNN	
11	PAOZZ	5305011389540	96906	MS51863-33	SCREW,TAPPING.....	2
					UOC:AVY,A11,A13,A14,A15,A20,A24,A25, A26,A27,B16,B17,B18,HVY	
11	PAOZZ	5305011389540	96906	MS51863-33	SCREW,TAPPING.....	4
					UOC:BVY,B15,B20,B24,B25,C17,NNN	

END OF FIGURE

**USE WITH A2 VEHICLES**

1  
2  
thru  
10

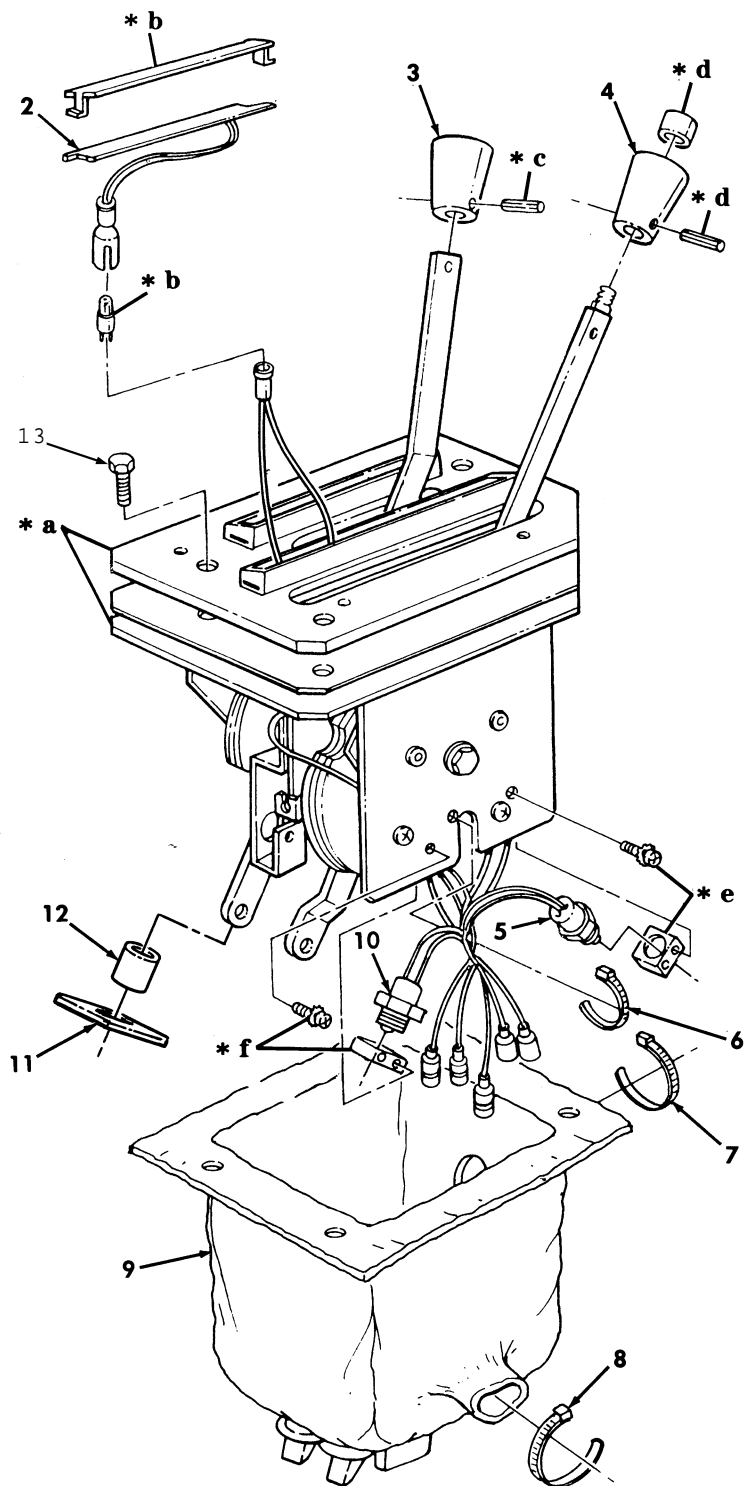

- \* a PART OF ITEM 1
- \* b PART OF ITEM 2
- \* c PART OF ITEM 3
- \* d PART OF ITEM 4
- \* e PART OF ITEM 5
- \* f PART OF ITEM 10

Figure 98. Transmission Shift Control and Neutral Start Switch.

SECTION II			TM9-2320-280-24P			
(1)	(2)	(3)	(4)	(5)	(6)	(7)
ITEM	SMR			PART		
NO	CODE	NSN	CAGEC	NUMBER	DESCRIPTION AND USABLE ON CODES(UOC)	QTY
GROUP 0705 TRANSMISSION SHIFTING COMPONENTS						
FIG. 98 TRANSMISSION SHIFT CONTROL AND NEUTRAL START SWITCH						
1	PAOOO	2520014132595	34623	6005790-A	CONTROL ASSEMBLY,GA.....	1
					UOC:BVY,B24,B25,C17,NNN	
1	PAOOO	2520014132612	34623	12460112	CONTROL ASSEMBLY,GA.....	1
					UOC:B15,B20	
2	PAOZZ	2540014630200	34623	5714588	.INDICATOR,SHIFT.....	1
					UOC:BVY,B15,B20,B24,B25,C17,NNN	
3	PAOZZ	5355014604586	34623	5743156	.KNOB KIT.....	1
					UOC:BVY,B15,B20,B24,B25,C17,NNN	
4	PAOZZ	5355014479655	60602	59267-1	.KNOB.....	1
					UOC:BVY,B15,B20,B24,B25,C17,NNN	
5	PAOZZ	2920014611065	34623	5714585	.SWITCH,SAFETY,NEUTR.....	1
					UOC:BVY,B15,B20,B24,B25,C17,NNN	
6	PAOZZ	5975009032284	06383	SST1M-C0	.STRAP,TIEDOWN,ELECT.....	2
					UOC:BVY,B15,B20,B24,B25,C17,NNN	
6	PAOZZ	5975009032288	96906	MS3367-4-2	.STRAP,TIEDOWN,ELECT.....	2
					UOC:BVY,B15,B20,B24,B25,C17,NNN	
7	PAOZZ	5975010345871	96906	MS3367-7-0	.STRAP,TIEDOWN,ELECT.....	1
					UOC:BVY,B15,B20,B24,B25,C17,NNN	
8	PAOZZ	5975000742072	96906	MS3367-1-9	.STRAP,TIEDOWN,ELECT 3/16" X 7.25".	1
					UOC:BVY,B15,B20,B24,B25,C17,NNN	
9	PAOZZ	5340014561500	60602	51078-1	.BOOT,DUST AND MOIST.....	1
					UOC:BVY,B15,B20,B24,B25,C17,NNN	
10	PAOZZ	2920014762716	34623	5743159	.SWITCH,SAFETY,NEUTR.....	1
					UOC:BVY,B15,B20,B24,B25,C17,NNN	
11	PAOZZ	5340014728534	19207	12460507	PLATE,MOUNTING.....	2
					UOC:BVY,B15,B20,B24,B25,C17,NNN	
12	PAOZZ	5970013597836	81349	M23053/15-202-0	INSULATION SLEEVING 1 INCH LONG....	2
					UOC:BVY,B15,B20,B24,B25,C17,NNN	
13	PAOZZ	5305000712505	80204	B1821BH025C088N	SCREW,CAP,HEXAGON H 1/4-20 X 7/8...	4
					UOC:BVY,B15,B20,B24,B25,C17,NNN	

END OF FIGURE

**USE WITH BASIC AND A1 VEHICLES**

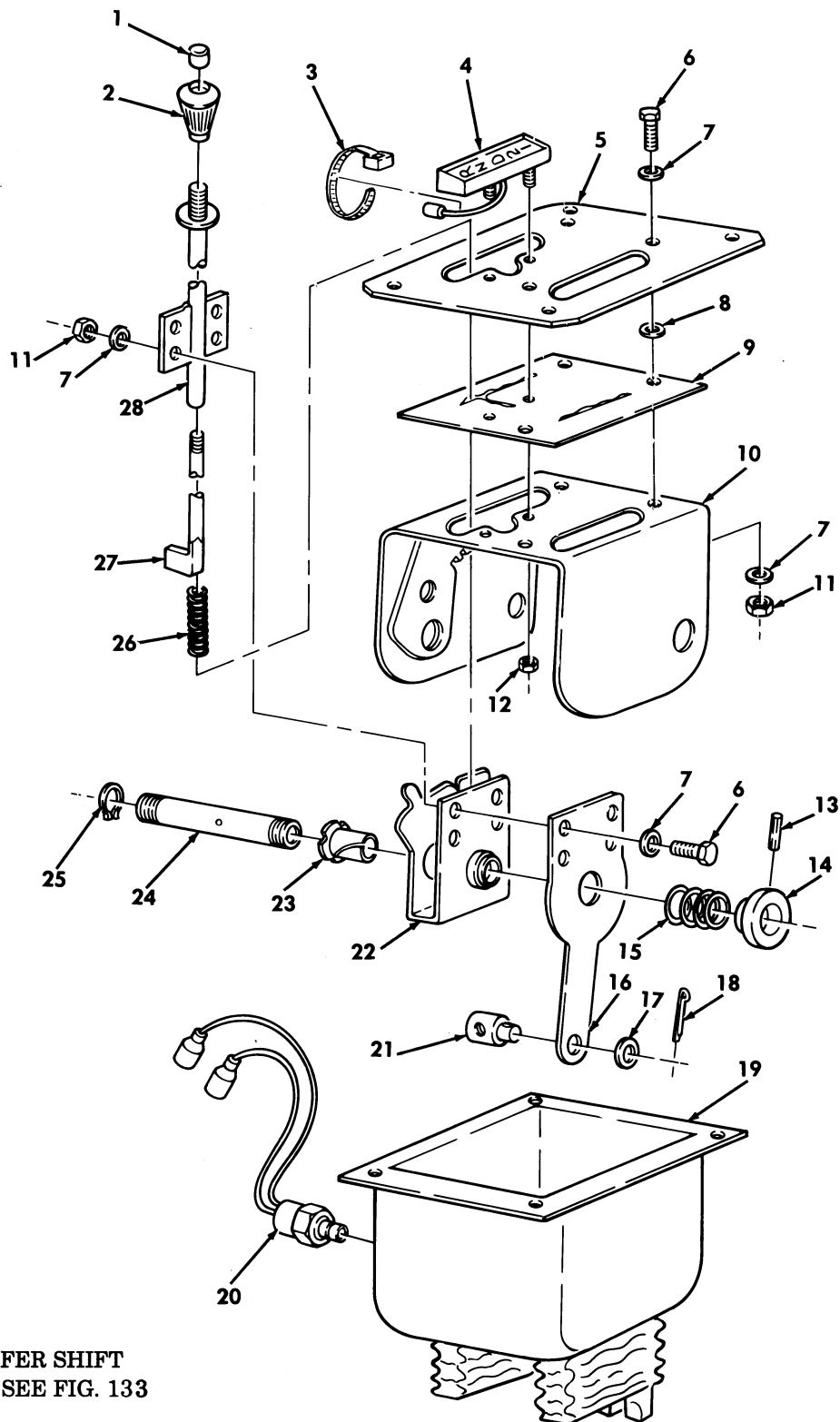

FOR TRANSFER SHIFT  
CONTROLS SEE FIG. 133

Figure 99. Transmission Shift Control and Neutral Start Switch.

SECTION II			TM9-2320-280-24P			
(1)	(2)	(3)	(4)	(5)	(6)	(7)
ITEM NO	SMR CODE	NSN	CAGEC	PART NUMBER	DESCRIPTION AND USABLE ON CODES(UOC)	QTY
GROUP 0705 TRANSMISSION SHIFTING COMPONENTS						
FIG. 99 TRANSMISSION SHIFT CONTROL AND NEUTRAL START SWITCH						
1	PFOZZ	2590011863614	19207	12338996	BUTTON, SHIFT KNOB..... UOC:AVY, A11, A13, A14, A15, A20, A24, A25, A26, A27, B16, B17, B18, HVY, H11, H13, H14, H15, H16, H17, H18, H20, H21, H24, H25, H26, H27, H28, MMM	1
2	PFOZZ	5355011907635	34623	5578673	KNOB..... UOC:AVY, A11, A13, A14, A15, A20, A24, A25, A26, A27, B16, B17, B18, HVY, H11, H13, H14, H15, H16, H17, H18, H20, H21, H24, H25, H26, H27, H28, MMM	1
3	PAOZZ	5975009032284	96906	MS3367-4-0	STRAP, TIEDOWN, ELECT..... UOC:AVY, A11, A13, A14, A15, A20, A24, A25, A26, A27, B16, B17, B18, HVY, H11, H13, H14, H15, H16, H17, H18, H20, H21, H24, H25, H26, H27, H28, MMM	1
4	PAOZZ	2540011845502	19207	12338439	INDICATOR, SHIFT..... UOC:AVY, A11, A13, A14, A15, A20, A24, A25, A26, A27, B16, B17, B18, HVY, H11, H13, H14, H15, H16, H17, H18, H20, H21, H24, H25, H26, H27, H28, MMM	1
5	PFOZZ	5340011885072	19207	12338457	COVER, ACCESS..... UOC:AVY, A11, A13, A14, A15, A20, A24, A25, A26, A27, B16, B17, B18, HVY, H11, H13, H14, H15, H16, H17, H18, H20, H21, H24, H25, H26, H27, H28, MMM	1
6	PAOZZ	5305000712505	80204	B1821BH025C088N	SCREW, CAP, HEXAGON H 1/4-20 X 7/8... UOC:AVY, A11, A13, A14, A15, A20, A24, A25, A26, A27, B16, B17, B18, HVY, H11, H13, H14, H15, H16, H17, H18, H20, H21, H24, H25, H26, H27, H28, MMM	7
7	PAOZZ	5310011023270	24617	2436161	WASHER, FLAT 1/4..... UOC:AVY, A11, A13, A14, A15, A20, A24, A25, A26, A27, B16, B17, B18, HVY, H11, H13, H14, H15, H16, H17, H18, H20, H21, H24, H25, H26, H27, H28, MMM	14
8	PAOZZ	5310012510748	34623	5593691	WASHER, FLAT .319 I.D. X .500 O.D... UOC:AVY, A11, A13, A14, A15, A20, A24, A25, A26, A27, B16, B17, B18, HVY, H11, H13, H14, H15, H16, H17, H18, H20, H21, H24, H25, H26, H27, H28, MMM	3
9	PFOZZ	3040012491435	19207	12338456	PLATE, RETAINING, SHA..... UOC:AVY, A11, A13, A14, A15, A20, A24, A25, A26, A27, B16, B17, B18, HVY, H11, H13, H14, H15, H16, H17, H18, H20, H21, H24, H25, H26, H27, H28, MMM	1
10	XAOZZ		34623	SF-5583585	HOUSING ASSEMBLY..... UOC:AVY, A11, A13, A14, A15, A20, A24, A25,	1

SECTION II			TM9-2320-280-24P			
(1)	(2)	(3)	(4)	(5)	(6)	(7)
ITEM	SMR			PART		
NO	CODE	NSN	CAGEC	NUMBER	DESCRIPTION AND USABLE ON CODES(UOC)	QTY
11	PAOZZ	5310000614650	96906	MS51943-31	A26,A27,B16,B17,B18,HVY,H11,H13,H14, H15,H16,H17,H18,H20,H21,H24,H25,H26, H27,H28,MMM NUT,SELF-LOCKING,HE 1/4-20.....	7
					UOC:AVY,A11,A13,A14,A15,A20,A24,A25, A26,A27,B16,B17,B18,HVY,H11,H13,H14, H15,H16,H17,H18,H20,H21,H24,H25,H26, H27,H28,MMM	
12	PAOZZ	5310012506587	34623	5592998	NUT #8-32.....	2
					UOC:AVY,A11,A13,A14,A15,A20,A24,A25, A26,A27,B16,B17,B18,HVY,H11,H13,H14, H15,H16,H17,H18,H20,H21,H24,H25,H26, H27,H28,MMM	
13	PAOZZ	5315005597467	80205	NAS561C4-18	PIN,SPRING 1/8 X 1.12.....	1
					UOC:AVY,A11,A13,A14,A15,A20,A24,A25, A26,A27,B16,B17,B18,HVY,H11,H13,H14, H15,H16,H17,H18,H20,H21,H24,H25,H26, H27,H28,MMM	
14	PFOZZ	3040011985699	19207	12338452	COLLAR,SHAFT.....	1
					UOC:AVY,A11,A13,A14,A15,A20,A24,A25, A26,A27,B16,B17,B18,HVY,H11,H13,H14, H15,H16,H17,H18,H20,H21,H24,H25,H26, H27,H28,MMM	
15	PAOZZ	5360011906218	92830	M-C1100-096-0875	SPRING,HELICAL,COMP.....	1
					UOC:AVY,A11,A13,A14,A15,A20,A24,A25, A26,A27,B16,B17,B18,HVY,H11,H13,H14, H15,H16,H17,H18,H20,H21,H24,H25,H26, H27,H28,MMM	
16	PFOZZ	2520011891064	19207	12338443	LEVER,REMOTE CONTRO.....	1
					UOC:AVY,A11,A13,A14,A15,A20,A24,A25, A26,A27,B16,B17,B18,HVY,H11,H13,H14, H15,H16,H17,H18,H20,H21,H24,H25,H26, H27,H28,MMM	
17	PAOZZ	5310012507836	34623	5593285	WASHER,FLAT 3/8.....	1
					UOC:AVY,A11,A13,A14,A15,A20,A24,A25, A26,A27,B16,B17,B18,HVY,H11,H13,H14, H15,H16,H17,H18,H20,H21,H24,H25,H26, H27,H28,MMM	
18	PAOZZ	5315008423044	14351	X601	PIN,COTTER 3/32 X 3/4.....	1
					UOC:AVY,A11,A13,A14,A15,A20,A24,A25, A26,A27,B16,B17,B18,HVY,H11,H13,H14, H15,H16,H17,H18,H20,H21,H24,H25,H26, H27,H28,MMM	
19	PAOZZ	2520011888269	19207	12338458-1	BOOT,POWER TRANSMIS.....	1
					UOC:AVY,A11,A13,A14,A24,A25,A26,A27, B17,B18,HVY,H11,H13,H14,H17,H18,H21, H24,H25,H26,H27,H28,MMM	
19	PAOZZ	2520012103506	34623	5584110	BOOT,POWER TRANSMIS.....	1
					UOC:A15,A20,B16,B20,H15,H16,H20	
20	PAOZZ	2920012493492	19207	12338434	SWITCH,SAFETY,NEUTR.....	1
					UOC:AVY,A11,A13,A14,A15,A20,A24,A25, A26,A27,B16,B17,B18,HVY,H11,H13,H14, H15,H16,H17,H18,H20,H21,H24,H25,H26,	

SECTION II			TM9-2320-280-24P			
(1)	(2)	(3)	(4)	(5)	(6)	(7)
ITEM	SMR			PART		
NO	CODE	NSN	CAGEC	NUMBER	DESCRIPTION AND USABLE ON CODES(UOC)	QTY
21	PAOZZ	3040011854388	19207	12338442-1	H27, H28, MMM HUB, BODY.....	1
					UOC:AVY, A11, A13, A14, A15, A20, A24, A25, A26, A27, B16, B17, B18, HVY, H11, H13, H14, H15, H16, H17, H18, H20, H21, H24, H25, H26, H27, H28, MMM	
22	PFOZZ	2520011847036	19207	12338454	BRACKET AND SHAFT A.....	1
					UOC:AVY, A11, A13, A14, A15, A20, A24, A25, A26, A27, B16, B17, B18, HVY, H11, H13, H14, H15, H16, H17, H18, H20, H21, H24, H25, H26, H27, H28, MMM	
23	PFOZZ	3120011913232	96881	10L18F	BEARING, SLEEVE.....	1
					UOC:AVY, A11, A13, A14, A15, A20, A24, A25, A26, A27, B16, B17, B18, HVY, H11, H13, H14, H15, H16, H17, H18, H20, H21, H24, H25, H26, H27, H28, MMM	
24	PFOZZ	3040011892134	19207	12338451	SHAFT, STRAIGHT.....	1
					UOC:AVY, A11, A13, A14, A15, A20, A24, A25, A26, A27, B16, B17, B18, HVY, H11, H13, H14, H15, H16, H17, H18, H20, H21, H24, H25, H26, H27, H28, MMM	
25	PAOZZ	5325008037305	96906	MS16624-1062	RING, RETAINING.....	1
					UOC:AVY, A11, A13, A14, A15, A20, A24, A25, A26, A27, B16, B17, B18, HVY, H11, H13, H14, H15, H16, H17, H18, H20, H21, H24, H25, H26, H27, H28, MMM	
26	PAOZZ	5360011864844	34623	5578675	SPRING, HELICAL, COMP.....	1
					UOC:AVY, A11, A13, A14, A15, A20, A24, A25, A26, A27, B16, B17, B18, HVY, H11, H13, H14, H15, H16, H17, H18, H20, H21, H24, H25, H26, H27, H28, MMM	
27	PFOZZ	5342011883233	19207	12338441	ROD, SHIFT LEVER LAT.....	1
					UOC:AVY, A11, A13, A14, A15, A20, A24, A25, A26, A27, B16, B17, B18, HVY, H11, H13, H14, H15, H16, H17, H18, H20, H21, H24, H25, H26, H27, H28, MMM	
28	PFOZZ	3040011883234	34623	12338449	SHAFT, STRAIGHT.....	1
					UOC:AVY, A11, A13, A14, A15, A20, A24, A25, A26, A27, B16, B17, B18, HVY, H11, H13, H14, H15, H16, H17, H18, H20, H21, H24, H25, H26, H27, H28, MMM	

END OF FIGURE



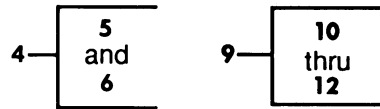

**USE WITH BASIC AND A1 VEHICLES**

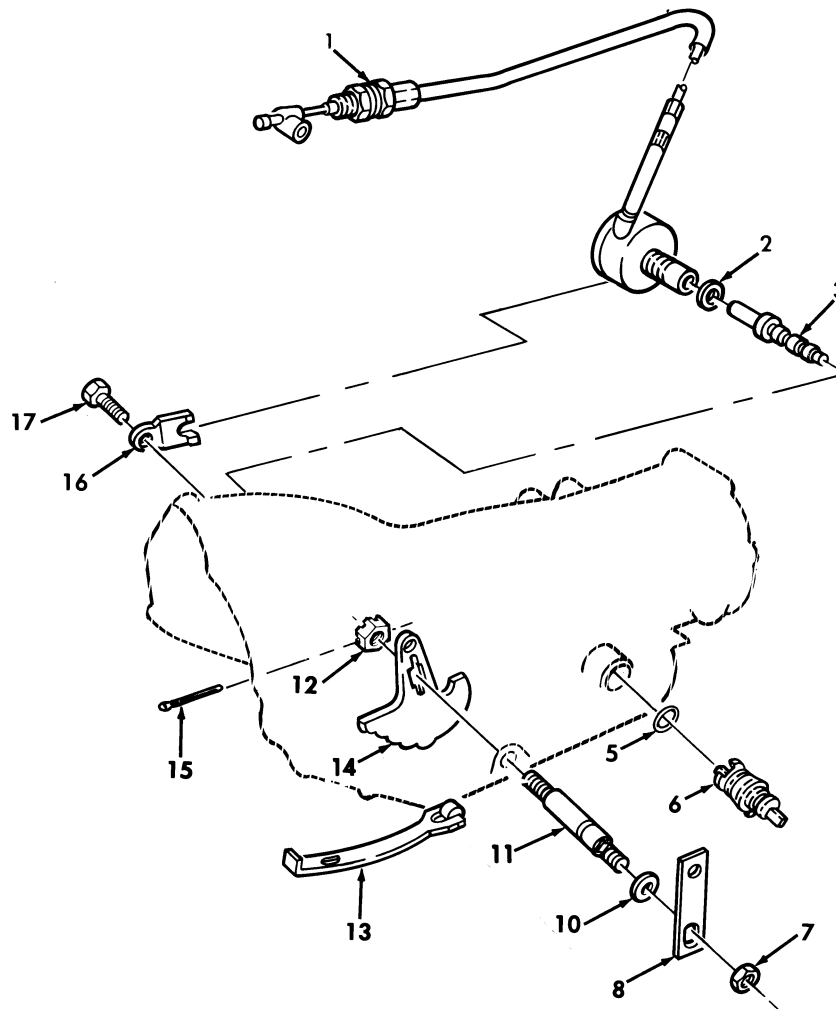

Figure 100. Transmission Shift Controls and Modulator.

SECTION II			TM9-2320-280-24P			
(1)	(2)	(3)	(4)	(5)	(6)	(7)
ITEM NO	SMR CODE	NSN	CAGEC	PART NUMBER	DESCRIPTION AND USABLE ON CODES(UOC)	QTY
GROUP 0705 TRANSMISSION SHIFTING COMPONENTS						
FIG. 100 TRANSMISSION SHIFT CONTROLS AND MODULATOR						
1	PAOZZ	2520012449863	60602	000-02136-0024	MODULATOR, TRANSMISS..... UOC:AVY,A11,A13,A14,A15,A20,A24,A25, A26,A27,B16,B17,B18,HVY,H11,H13,H14, H15,H16,H17,H18,H20,H21,H24,H25,H26, H27,H28,MMM	1
2	PAOZZ	5330010435572	73342	8658110	RETAINER, PACKING..... UOC:AVY,A11,A13,A14,A15,A20,A24,A25, A26,A27,B16,B17,B18,HVY,H11,H13,H14, H15,H16,H17,H18,H20,H21,H24,H25,H26, H27,H28,MMM	1
3	PAFZZ	4820011474294	7X677	8623983	SLIDE, DIRECTIONAL C..... UOC:AVY,A11,A13,A14,A15,A20,A24,A25, A26,A27,B16,B17,B18,HVY,H11,H13,H14, H15,H16,H17,H18,H20,H21,H24,H25,H26, H27,H28,MMM	1
4	PAHZZ	5935011506319	7X677	24205373	CONNECTOR, PLUG, ELEC..... UOC:AVY,A11,A13,A14,A15,A20,A24,A25, A26,A27,B16,B17,B18,HVY,H11,H13,H14, H15,H16,H17,H18,H20,H21,H24,H25,H26, H27,H28,MMM	1
5	PAHZZ	5330010435572	73342	8658110	.RETAINER, PACKING..... UOC:AVY,A11,A13,A14,A15,A20,A24,A25, A26,A27,B16,B17,B18,HVY,H11,H13,H14, H15,H16,H17,H18,H20,H21,H24,H25,H26, H27,H28,MMM	1
6	XAHZZ		11862	8626252	.CONNECTOR, ELECTRIC..... UOC:AVY,A11,A13,A14,A15,A20,A24,A25, A26,A27,B16,B17,B18,HVY,H11,H13,H14, H15,H16,H17,H18,H20,H21,H24,H25,H26, H27,H28,MMM	1
7	PAOZZ	5310011272456	K1076	9145-105-00B	NUT, PLAIN, HEXAGON 10-1.5MM..... UOC:AVY,A11,A13,A14,A15,A20,A24,A25, A26,A27,B16,B17,B18,HVY,H11,H13,H14, H15,H16,H17,H18,H20,H21,H24,H25,H26, H27,H28,MMM	1
8	PAOZZ	3040011888292	19207	12339176	CONNECTING LINK, RIG..... UOC:AVY,A11,A13,A14,A15,A20,A24,A25, A26,A27,B16,B17,B18,HVY,H11,H13,H14, H15,H16,H17,H18,H20,H21,H24,H25,H26, H27,H28,MMM	1
9	PAFZZ	2520011647158	7X677	8679990	PARTS KIT, MANUAL SH..... UOC:AVY,A11,A13,A14,A15,A20,A24,A25, A26,A27,B16,B17,B18,HVY,H11,H13,H14, H15,H16,H17,H18,H20,H21,H24,H25,H26, H27,H28	1
10	PAFZZ	5330012511607	7X677	8657163	.GASKET..... UOC:AVY,A11,A13,A14,A15,A20,A24,A25,	1

SECTION II			TM9-2320-280-24P			
(1)	(2)	(3)	(4)	(5)	(6)	(7)
ITEM NO	SMR CODE	NSN	CAGEC	PART NUMBER	DESCRIPTION AND USABLE ON CODES(UOC)	QTY
11	XAFZZ		72590	8626982	A26,A27,B16,B17,B18,HVY,H11,H13,H14, H15,H16,H17,H18,H20,H21,H24,H25,H26, H27,H28,MMM .SHAFT, SHOULDERED..... UOC:AVY,A11,A13,A14,A15,A20,A24,A25, A26,A27,B16,B17,B18,HVY,H11,H13,H14, H15,H16,H17,H18,H20,H21,H24,H25,H26, H27,H28,MMM	1
12	PAFZZ	5310005686077	24617	117212	.NUT,PLAIN,HEXAGON 3/8-24..... UOC:AVY,A11,A13,A14,A15,A20,A24,A25, A26,A27,B16,B17,B18,HVY,H11,H13,H14, H15,H16,H17,H18,H20,H21,H24,H25,H26, H27,H28,MMM	1
13	PAFZZ	2520011659563	7X677	8625773	ROLLER AND SPRING A..... UOC:AVY,A11,A13,A14,A15,A20,A24,A25, A26,A27,B16,B17,B18,HVY,H11,H13,H14, H15,H16,H17,H18,H20,H21,H24,H25,H26, H27,H28,MMM	1
14	PAFZZ	2530011813907	34623	5740321	DETENT PLATE..... UOC:AVY,A11,A13,A14,A15,A20,A24,A25, A26,A27,B16,B17,B18,HVY,H11,H13,H14, H15,H16,H17,H18,H20,H21,H24,H25,H26, H27,H28,MMM	1
15	PAFZZ	5315011529029	73342	23017556	PIN,STRAIGHT,HEADED 3/32 X 1.88.... UOC:AVY,A11,A13,A14,A15,A20,A24,A25, A26,A27,B16,B17,B18,HVY,H11,H13,H14, H15,H16,H17,H18,H20,H21,H24,H25,H26, H27,H28,MMM	1
16	PAOZZ	2520005576619	73342	8627650	RETAINER,MODULATOR..... UOC:AVY,A11,A13,A14,A15,A20,A24,A25, A26,A27,B16,B17,B18,HVY,H11,H13,H14, H15,H16,H17,H18,H20,H21,H24,H25,H26, H27,H28,MMM	1
17	PAOZZ	5306002264825	80204	B1821BH031C075N	BOLT,MACHINE 5/16-18 X 3/4..... UOC:AVY,A11,A13,A14,A15,A20,A24,A25, A26,A27,B16,B17,B18,HVY,H11,H13,H14, H15,H16,H17,H18,H20,H21,H24,H25,H26, H27,H28,MMM	1

END OF FIGURE

9	10 and 11
---	-----------------

**USE WITH A2 VEHICLES**

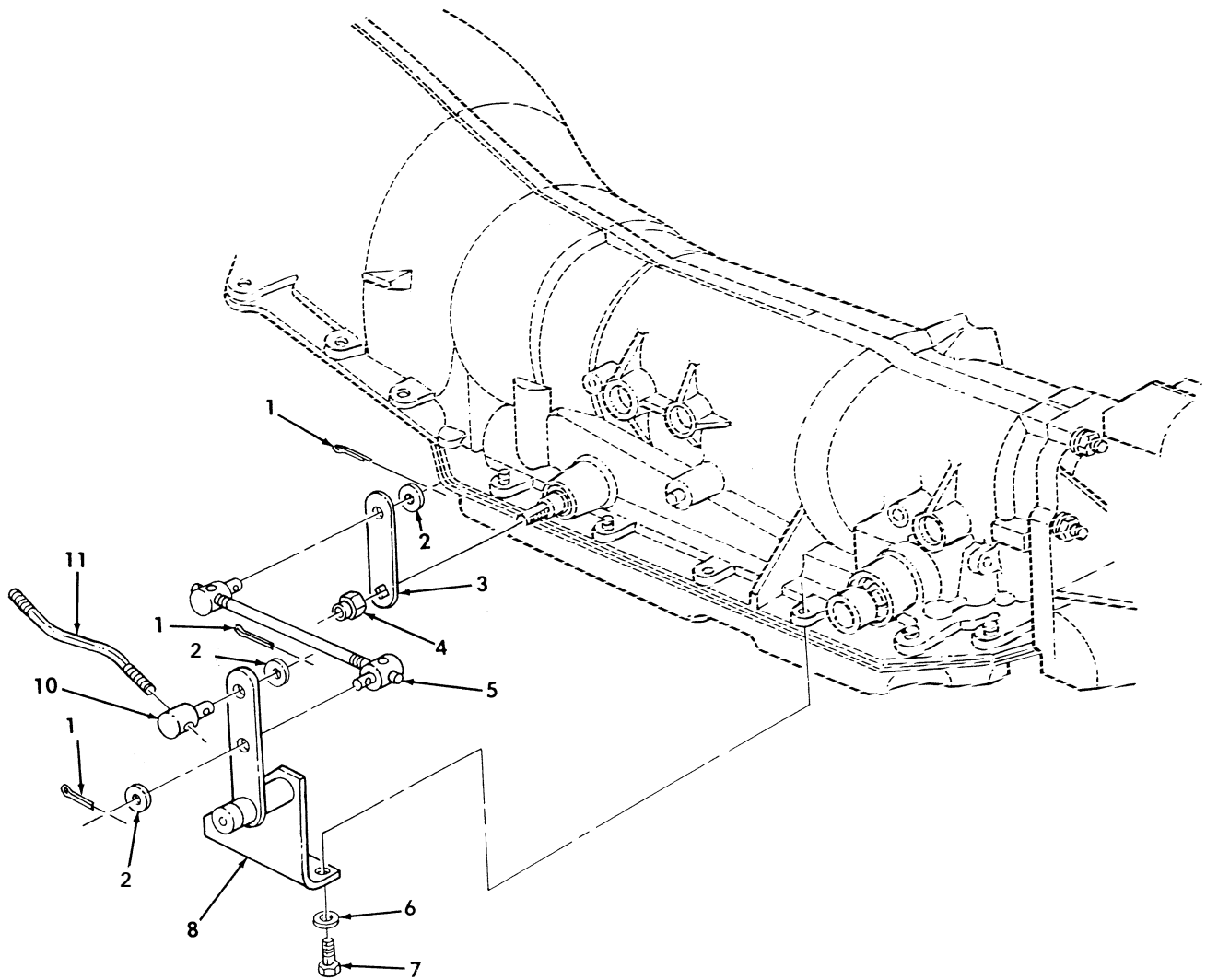

*Figure 101. Transmission Shift Lever, Shift Bracket, and Rod.*

SECTION II			TM9-2320-280-24P			
(1)	(2)	(3)	(4)	(5)	(6)	(7)
ITEM NO	SMR CODE	NSN	CAGEC	PART NUMBER	DESCRIPTION AND USABLE ON CODES(UOC)	QTY
GROUP 0705 TRANSMISSION SHIFTING COMPONENTS						
FIG. 101 TRANSMISSION SHIFT LEVER, SHIFT BRACKET, AND ROD						
1	PAOZZ	5315008423044	80205	NASM24665-283	PIN, COTTER 3/32 X 3/4.....	4
					UOC: BVY, B15, B20, B24, B25, C17, NNN	
2	PAOZZ	5310001670821	88044	AN960-616	WASHER, FLAT.....	4
					UOC: BVY, B15, B20, B24, B25, C17, NNN	
3	PAOZZ	3040014092502	34623	6003175	CONNECTING LINK, RIG.....	1
					UOC: BVY, B15, B20, B24, B25, C17, NNN	
4	PAOZZ	5310011552503	7X677	11514603	NUT, PLAIN, HEXAGON 10-1.5MM.....	1
					UOC: BVY, B17, B20, B24, B25, C17, NNN	
5	PAOZZ	3040014108054	60602	52827-1	CONNECTING LINK, RIG.....	1
					UOC: BVY, B15, B20, B24, B25, C17, NNN	
6	PAOZZ	5310014165447	24617	11500161	WASHER, LOCK 8MM.....	2
					UOC: BVY, B15, B20, B24, B25, C17, NNN	
7	PAOZZ	5306014112342	7X677	11505074	BOLT, MACHINE 8-1.25 X 35MM.....	2
					UOC: BVY, B15, B20, B24, B25, C17, NNN	
8	PAOZZ	3040014109965	60602	52826-1	LEVER ASSEMBLY, REMO.....	1
					UOC: BVY, B15, B20, B24, B25, C17, NNN	
9	PAOZZ	3040014092500	34623	12460146	CONNECTING LINK, RIG.....	1
					UOC: BVY, B15, B20, B24, B25, C17, NNN	
10	PAOZZ	2520012491434	34623	5593661	. TRUNNION, SHIFT CONT.....	2
					UOC: BVY, B15, B20, B24, B25, C17, NNN	
11	XAOZZ		19207	12460066	. ROD.....	1
					UOC: BVY, B15, B20, B24, B25, C17, NNN	

END OF FIGURE

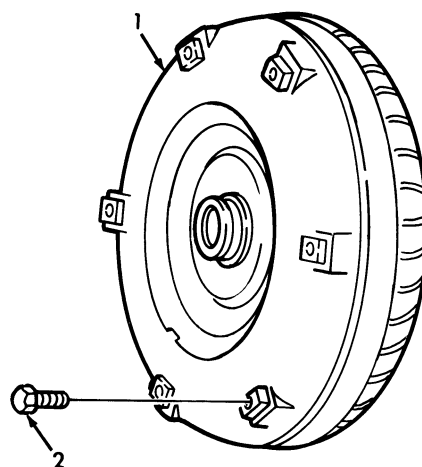
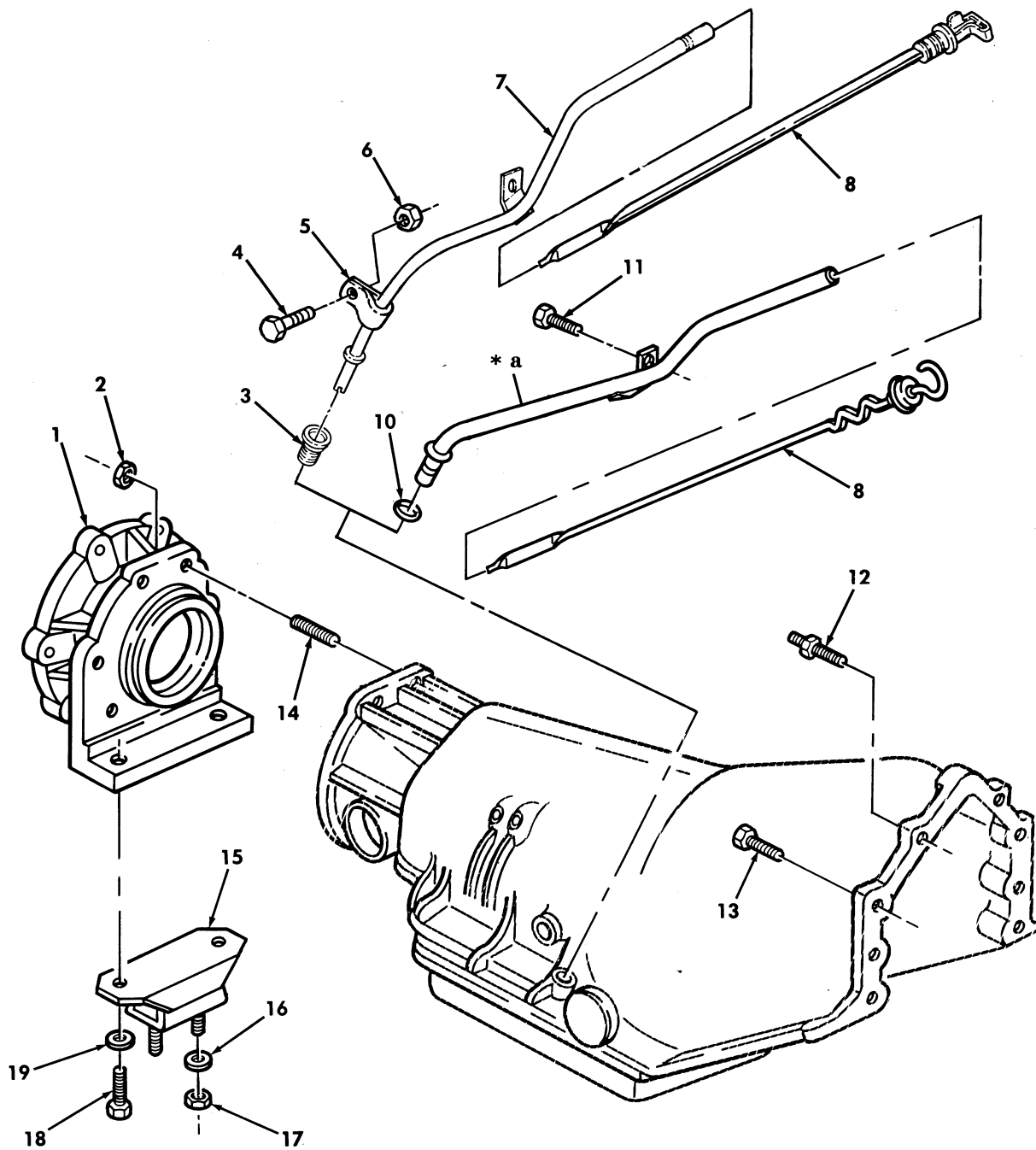

Figure 102. Torque Converter.

SECTION II			TM9-2320-280-24P			
(1)	(2)	(3)	(4)	(5)	(6)	(7)
ITEM NO	SMR CODE	NSN	CAGEC	PART NUMBER	DESCRIPTION AND USABLE ON CODES(UOC)	QTY
					GROUP 0708 TORQUE CONVERTER AND FLUID COUPLING	
					FIG. 102 TORQUE CONVERTER	
1	PAFZZ	2520011647234	7X677	8656942	TORQUE CONVERTER..... UOC:AVY,A11,A13,A14,A15,A20,A24,A25, A26,A27,B16,B17,B18,HVY,H11,H13,H14, H15,H16,H17,H18,H20,H21,H24,H25,H26, H27,H28,MMM	1
1	PAFZZ	2520014084785	7X677	08689960	TORQUE CONVERTER,VE 1995.....	1
1	PAFZZ	2520014608323	7X677	24204835	TORQUE CONVERTER,VE 1996,97,98..... UOC:BVY,B15,B20,B24,B25,C17,NNN	1
2	PAFZZ	5305011885133	19207	12340514	SCREW,CAP,HEXAGON H #10-1.5 X 60 MM	6

END OF FIGURE

9-10



\* a PART OF ITEM 9

Figure 103. Transmission Mounting Hardware, Fluid Dipstick, and Tube Assembly.



SECTION II			TM9-2320-280-24P			
(1)	(2)	(3)	(4)	(5)	(6)	(7)
ITEM NO	SMR CODE	NSN	CAGEC	PART NUMBER	DESCRIPTION AND USABLE ON CODES(UOC)	QTY
GROUP 0710 TRANSMISSION ASSEMBLY						
FIG. 103 TRANSMISSION MOUNTING HARDWARE, FLUID DIPSTICK, AND TUBE ASSEMBLY						
1	PPFZZ	2520011757220	19207	12339134	ADAPTER ASSEMBLY, PU..... UOC:AVY,A11,A13,A14,A15,A20,A24,A25, A26,A27,B16,B17,B18,HVY,H11,H13,H14, H15,H16,H17,H18,H20,H21,H24,H25,H26, H27,H28,MMM	1
1	PPFZZ	2520014641774	34623	12447175	ADAPTER ASSEMBLY, PU..... UOC:BVY,B15,B20,B24,B25,C17,NNN	1
2	PAFZZ	5310004478774	96906	MS51988-8	NUT, SELF-LOCKING, EX 3/8-24.....	6
3	PAOZZ	5330014474762	19207	12447172	SEAL, NONMETALLIC SP..... UOC:BVY,B15,B20,B24,B25,C17,NNN	1
4	PAOZZ	5305000712506	80204	B1821BH025C050N	SCREW, CAP, HEXAGON H.....	1
5	PAOZZ	5340011661672	24617	120528	CLAMP, LOOP.....	1
6	PAOZZ	5310000614650	96906	MS51943-31	NUT, SELF-LOCKING, HE.....	1
7	PAOZZ	2590014122664	19207	12447173	FILLER NECK..... UOC:BVY,B15,B20,B24,B25,C17,NNN	1
8	PAOZZ	6680011849214	19207	12339167	GAGE ROD-CAP, LIQUID FOR DEEP WATER FORDING REFER TO 3305..... UOC:AVY,A11,A13,A14,A15,A20,A24,A25, A26,A27,B16,B17,B18,HVY,H11,H13,H14, H15,H16,H17,H18,H20,H21,H24,H25,H26, H27,H28,MMM	1
8	PAOZZ	6680014667238	19207	12460314	GAGE ROD-CAP, LIQUID..... UOC:BVY,B15,B20,B24,B25,C17,NNN	1
9	PFOZZ	4710011883238	34623	5582840	TUBE, BENT, METALLIC FOR DEEP WATER FORDING REFER TO 3305..... UOC:AVY,A11,A13,A14,A15,A20,A24,A25, A26,A27,B16,B17,B18,HVY,H11,H13,H14, H15,H16,H17,H18,H20,H21,H24,H25,H26, H27,H28,MMM	1
10	PAOZZ	5330011846492	02697	2-113N497-70	. PACKING, PREFORMED..... UOC:AVY,A11,A13,A14,A15,A20,A24,A25, A26,A27,B16,B17,B18,HVY,H11,H13,H14, H15,H16,H17,H18,H20,H21,H24,H25,H26, H27,H28,MMM	1
11	PAFZZ	5305012519222	34623	5593011	SCREW, CAP, HEXAGON H #10-1.5 X 16MM. UOC:AVY,A11,A13,A14,A15,A20,A24,A25, A26,A27,B16,B17,B18,HVY,H11,H13,H14, H15,H16,H17,H18,H20,H21,H24,H25,H26, H27,H28,MMM	1
12	PAFZZ	5307011907650	19207	12339662	STUD, SHOULDERED 3/8-16 X 2.40.....	2
13	PAFZZ	5305006882111	80204	B1821BH038C138N	SCREW, CAP, HEXAGON H 3/8-16 X 1-3/8.	4
14	PAFZZ	5307014465930	19207	12339518	STUD, SHOULDERED..... UOC:AVY,A11,A13,A14,A15,A20,A24,A25, A26,A27,B16,B17,B18,HVY,H11,H13,H14, H15,H16,H17,H18,H20,H21,H24,H25,H26, H27,H28,MMM	6
14	PAFZZ	5307014112336	34623	6002942	STUD, SHOULDERED.....	6

SECTION II			TM9-2320-280-24P			
(1)	(2)	(3)	(4)	(5)	(6)	(7)
ITEM	SMR			PART		
NO	CODE	NSN	CAGEC	NUMBER	DESCRIPTION AND USABLE ON CODES(UC)	QTY
					UOC:BVY,B15,B20,B24,B25,C17,NNN	
15	PAOZZ	5342011907735	34623	5589134	MOUNT,RESILIENT.....	1
16	PAOZZ	5310000877493	96906	MS27183-13	WASHER,FLAT 3/8.....	2
17	PAOZZ	5310009359021	96906	MS51943-35	NUT,SELF-LOCKING,HE 3/8-16.....	2
18	PAOZZ	5305007320511	80204	B1821BH050C113N	SCREW,CAP,HEXAGON H 1/2-13 X 1.125.	2
19	PAOZZ	5310005845272	02978	ERNA245	WASHER,LOCK 1/2.....	2

END OF FIGURE

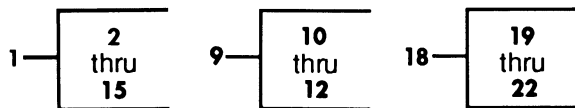

**USE WITH BASIC AND A1 VEHICLES**

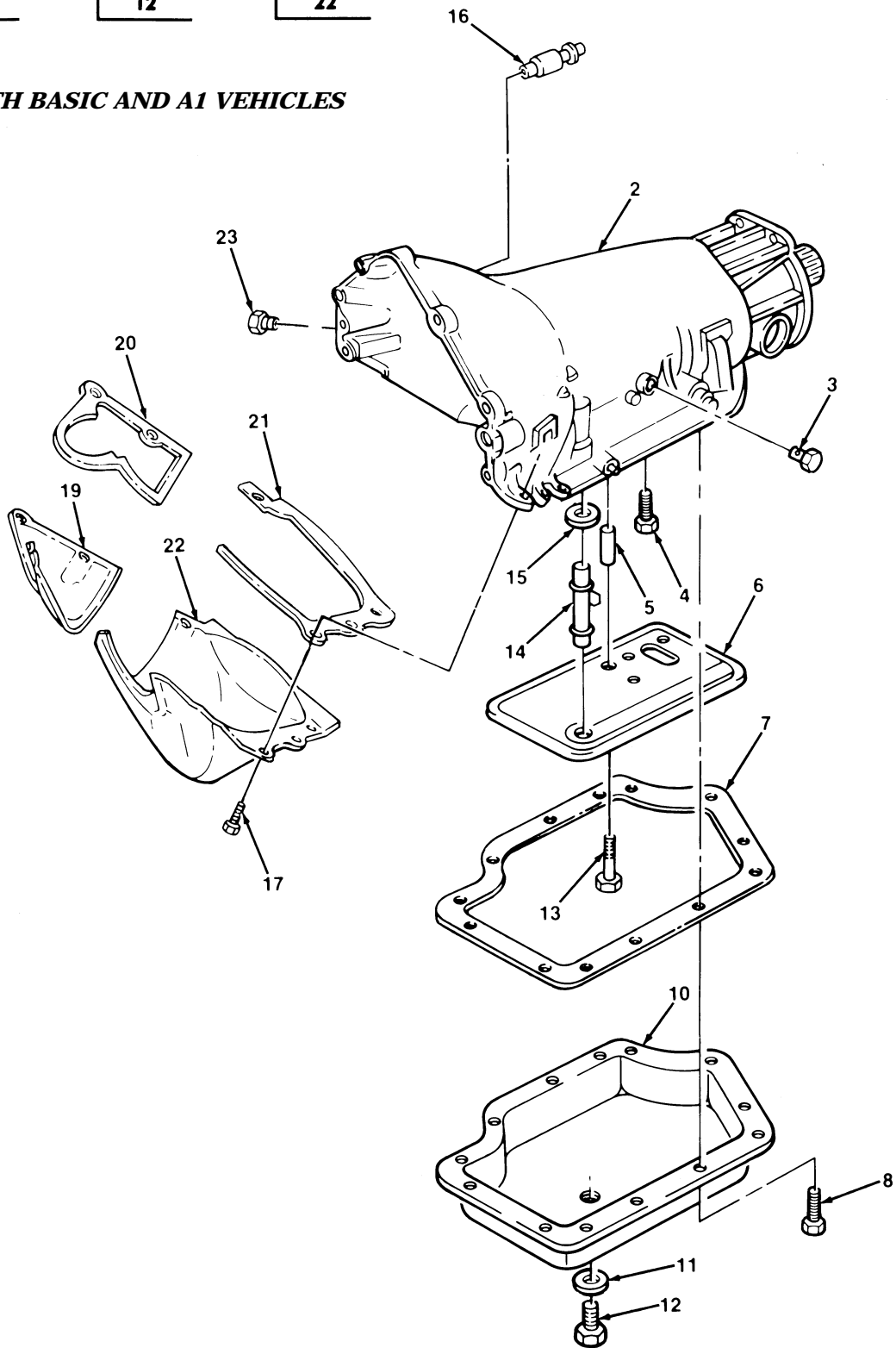

Figure 104. Transmission Assembly.

SECTION II			TM9-2320-280-24P			
(1)	(2)	(3)	(4)	(5)	(6)	(7)
ITEM	SMR			PART		
NO	CODE	NSN	CAGEC	NUMBER	DESCRIPTION AND USABLE ON CODES(UOC)	QTY
GROUP 0710 TRANSMISSION ASSEMBLY						
FIG. 104 TRANSMISSION ASSEMBLY						
1	PAFHH	2520011612136	19207	12339146	TRANSMISSION, HYDRAU.....	1
					UOC:AVY,A11,A13,A14,A15,A20,A24,A25,A26,A27,B16,B17,B18,HVY,H11,H13,H14,H15,H16,H17,H18,H20,H21,H24,H25,H26,H27,H28,MMM	
2	PAHZZ	3040014489611	7X677	8629991	.HOUSING,MECHANICAL.....	1
					UOC:AVY,A11,A13,A14,A15,A20,A24,A25,A26,A27,B16,B17,B18,HVY,H11,H13,H14,H15,H16,H17,H18,H20,H21,H24,H25,H26,H27,H28,MMM	
3	PAHZZ	4730011662244	81349	WW-P-471AQABUA	.PLUG,PIPE.....	1
					UOC:AVY,A11,A13,A14,A15,A20,A24,A25,A26,A27,B16,B17,B18,HVY,H11,H13,H14,H15,H16,H17,H18,H20,H21,H24,H25,H26,H27,H28,MMM	
4	PAHZZ	5306011504835	7X677	GM8670757	.BOLT, INTERNALLY REL.....	1
					UOC:AVY,A11,A13,A14,A15,A20,A24,A25,A26,A27,B16,B17,B18,HVY,H11,H13,H14,H15,H16,H17,H18,H20,H21,H24,H25,H26,H27,H28,MMM	
5	PAOZZ	5365011530872	7X677	8629523	.SPACER,SLEEVE.....	1
					UOC:AVY,A11,A13,A14,A15,A20,A24,A25,A26,A27,B16,B17,B18,HVY,H11,H13,H14,H15,H16,H17,H18,H20,H21,H24,H25,H26,H27,H28,MMM	
6	KFOZZ		73342	6437741	.PARTS KIT,FLUID PRE PART OF KIT P/N 12337210.....	1
					UOC:AVY,A11,A13,A14,A15,A20,A24,A25,A26,A27,B16,B17,B18,HVY,H11,H13,H14,H15,H16,H17,H18,H20,H21,H24,H25,H26,H27,H28,MMM	
7	PAOZZ	5330011487492	7X677	8655625	.GASKET PART OF KIT P/N 12337210....	1
					UOC:AVY,A11,A13,A14,A15,A20,A24,A25,A26,A27,B16,B17,B18,HVY,H11,H13,H14,H15,H16,H17,H18,H20,H21,H24,H25,H26,H27,H28,MMM	
8	PAOZZ	5306000246580	73342	3829139	.BOLT,MACHINE 5/16-18 X 1/2.....	13
					UOC:AVY,A11,A13,A14,A15,A20,A24,A25,A26,A27,B16,B17,B18,HVY,H11,H13,H14,H15,H16,H17,H18,H20,H21,H24,H25,H26,H27,H28,MMM	
9	PAOZZ	2520012127634	72590	8655036	.OIL PAN.....	1
					UOC:AVY,A11,A13,A14,A15,A20,A24,A25,A26,A27,B16,B17,B18,HVY,H11,H13,H14,H15,H16,H17,H18,H20,H21,H24,H25,H26,H27,H28,MMM	
10	XAOZZ		11862	8655037	..PAN.....	1
					UOC:AVY,A11,A13,A14,A15,A20,A24,A25,A26,A27,B16,B17,B18,HVY,H11,H13,H14,	

SECTION II			TM9-2320-280-24P			
(1)	(2)	(3)	(4)	(5)	(6)	(7)
ITEM	SMR			PART		
NO	CODE	NSN	CAGEC	NUMBER	DESCRIPTION AND USABLE ON CODES(UOC)	QTY
11	PAOZZ	5330001073925	7X677	14079550	H15,H16,H17,H18,H20,H21,H24,H25,H26, H27,H28,MMM ..GASKET.....	1
					UOC:AVY,A11,A13,A14,A15,A20,A24,A25, A26,A27,B16,B17,B18,HVY,H11,H13,H14, H15,H16,H17,H18,H20,H21,H24,H25,H26, H27,H28,MMM	
12	PAOZZ	5365011880782	72582	23011420	..PLUG,MACHINE THREAD.....	1
					UOC:AVY,A11,A13,A14,A15,A20,A24,A25, A26,A27,B16,B17,B18,HVY,H11,H13,H14, H15,H16,H17,H18,H20,H21,H24,H25,H26, H27,H28,MMM	
13	PAOZZ	5306011509497	7X677	8633208	.BOLT,SHOULDER.....	1
					UOC:AVY,A11,A13,A14,A15,A20,A24,A25, A26,A27,B16,B17,B18,HVY,H11,H13,H14, H15,H16,H17,H18,H20,H21,H24,H25,H26, H27,H28,MMM	
14	PAOZZ	4710011525798	7X677	8629526	.TUBE,BENT,METALLIC.....	1
					UOC:AVY,A11,A13,A14,A15,A20,A24,A25, A26,A27,B16,B17,B18,HVY,H11,H13,H14, H15,H16,H17,H18,H20,H21,H24,H25,H26, H27,H28,MMM	
15	PAOZZ	5330010803253	19207	12267802	.SEAL,NONMETALLIC RO PART OF KIT P/N 12337210.....	1
					UOC:AVY,A11,A13,A14,A15,A20,A24,A25, A26,A27,B16,B17,B18,HVY,H11,H13,H14, H15,H16,H17,H18,H20,H21,H24,H25,H26, H27,H28,MMM	
16	PAHZZ	4730011883296	19207	12340024	MENDER,HOSE.....	1
					UOC:AVY,A11,A13,A14,A15,A20,A24,A25, A26,A27,B16,B17,B18,HVY,H11,H13,H14, H15,H16,H17,H18,H20,H21,H24,H25,H26, H27,H28,MMM	
17	PAOZZ	5305012519222	34623	5593011	SCREW,CAP,HEXAGON H 10-1.5 X 16MM..	6
					UOC:AVY,A11,A13,A14,A15,A20,A24,A25, A26,A27,B16,B17,B18,HVY,H11,H13,H14, H15,H16,H17,H18,H20,H21,H24,H25,H26, H27,H28,MMM	
18	PAOZA	5342014484215	19207	12342144-1	DOOR,ACCESS 6.5 LITER DETUNED.....	1
					UOC:AVY,A11,A13,A14,A15,A20,A24,A25, A26,A27,B16,B17,B18,HVY,H11,H13,H14, H15,H16,H17,H18,H20,H21,H24,H25,H26, H27,H28,MMM	
18	PAOOO	5340013111633	19207	12342144	COVER,ACCESS 6.2 LITER.....	1
					UOC:AVY,A11,A13,A14,A15,A20,A24,A25, A26,A27,B16,B17,B18,HVY,H11,H13,H14, H15,H16,H17,H18,H20,H21,H24,H25,H26, H27,H28	
19	PAOZZ	5340013145602	19207	12342107	.COVER,ACCESS.....	1
					UOC:AVY,A11,A13,A14,A15,A20,A24,A25, A26,A27,B16,B17,B18,HVY,H11,H13,H14, H15,H16,H17,H18,H20,H21,H24,H25,H26, H27,H28,MMM	

SECTION II			TM9-2320-280-24P			
(1)	(2)	(3)	(4)	(5)	(6)	(7)
ITEM NO	SMR CODE	NSN	CAGEC	PART NUMBER	DESCRIPTION AND USABLE ON CODES(UOC)	QTY
20	PAOZZ	5330013151609	19207	12342105	.GASKET..... UOC:AVY,A11,A13,A14,A15,A20,A24,A25, A26,A27,B16,B17,B18,HVY,H11,H13,H14, H15,H16,H17,H18,H20,H21,H24,H25,H26, H27,H28,MMM	1
21	PAOZZ	5330013146781	19207	12342104	.GASKET 6.2 LITER..... UOC:AVY,A11,A13,A14,A15,A20,A24,A25, A26,A27,B16,B17,B18,HVY,H11,H13,H14, H15,H16,H17,H18,H20,H21,H24,H25,H26, H27,H28,MMM	1
21	PAOZZ	5350014734701	19207	12342104-1	.GASKET 6.5 LITER DETUNED..... UOC:AVY,A11,A13,A14,A15,A20,A24,A25, A26,A27,B16,B17,B18,HVY,H11,H13,H14, H15,H16,H17,H18,H20,H21,H24,H25,H26, H27,H28,MMM	1
22	XAOZZ		19207	12342106	.COVER, CONVERTER HOU 6.2 LITER..... UOC:AVY,A11,A13,A14,A15,A20,A24,A25, A26,A27,B16,B17,B18,HVY,H11,H13,H14, H15,H16,H17,H18,H20,H21,H24,H25,H26, H27,H28,MMM	1
22	XAOZZ		19207	12342106-3	.COVER, CONVERTER HOU 6.5 LITER DETUNED..... UOC:AVY,A11,A13,A14,A15,A20,A24,A25, A26,A27,B16,B17,B18,HVY,H11,H13,H14, H15,H16,H17,H18,H20,H21,H24,H25,H26, H27,H28,MMM	1
23	PAOZZ	4730011777501	7X677	8655186	ADAPTER, STRAIGHT, PI..... UOC:AVY,A11,A13,A14,A15,A20,A24,A25, A26,A27,B16,B17,B18,HVY,H11,H13,H14, H15,H16,H17,H18,H20,H21,H24,H25,H26, H27,H28,MMM	2

END OF FIGURE

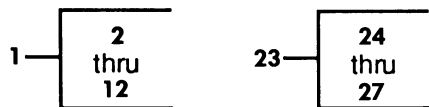

**USE WITH A2 VEHICLES**

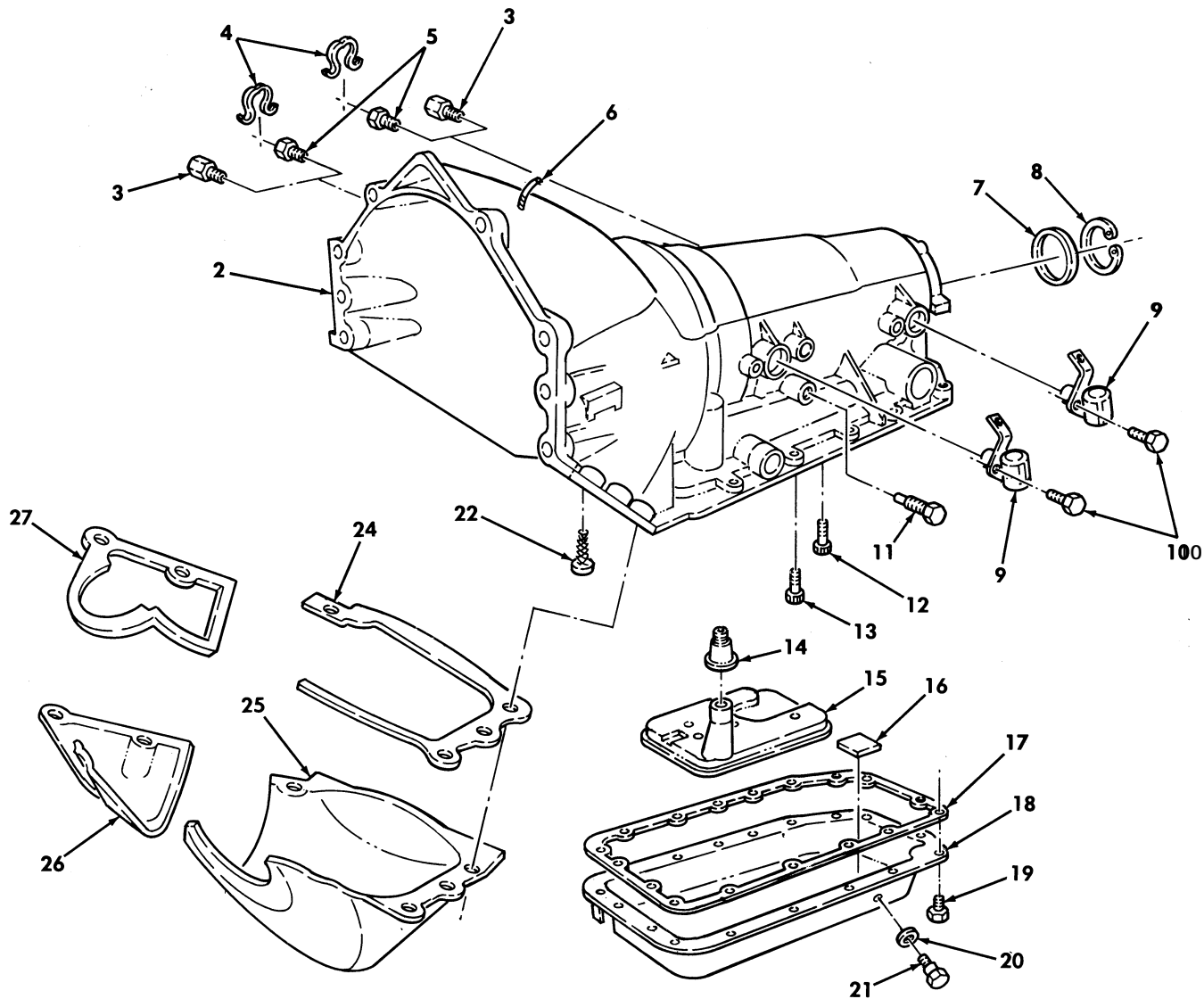

Figure 105. Transmission Assembly.

SECTION II		TM9-2320-280-24P				
(1)	(2)	(3)	(4)	(5)	(6)	(7)
ITEM NO	SMR CODE	NSN	CAGEC	PART NUMBER	DESCRIPTION AND USABLE ON CODES(UC)	QTY
GROUP 0710 TRANSMISSION ASSEMBLY						
FIG. 105 TRANSMISSION ASSEMBLY						
1	PAFHH	2520013994691	72590	24202329	TRANSMISSION,MECHAN 1995.....	1
					UC:BVY,B15,B20,B24,B25,C17,NNN	
1	KFFHH		72590	24205114	TRANSMISSION,HYDRAU 1996 PART OF	1
					KIT P/N 57K3502.....	
					UC:BVY,B15,B20,B24,B25,C17,NNN	
1	KFFHH		72590	24205225	TRANSMISSION,HYDRAU 1997 PART OF	1
					KIT P/N 57K3523.....	
					UC:BVY,B15,B20,B24,B25,C17,NNN	
1	KFFHH		72590	24208605	TRANSMISSION,HYDRAU 1998 PART OF	1
					KIT P/N 57K3539.....	
					UC:BVY,B15,B20,B24,B25,C17,NNN	
2	XAHZZ		7X677	24203366	.CASE,TRANSMISSION 1995,96.....	1
					UC:BVY,B15,B20,B24,B25,C17,NNN	
2	XAHZZ		7X677	24207168	.CASE,TRANSMISSION 1997,98.....	1
					UC:BVY,B15,B20,B24,B25,C17,NNN	
3	PAOZZ	4730011637163	7X677	8637742	.ADAPTER,STRAIGHT,PI.....	2
					UC:BVY,B15,B20,B24,B25,C17,NNN	
4	PAOZZ	5340014744011	7X677	24205103	.CLIP,RETAINING.....	2
					UC:BVY,B15,B20,B24,B25,C17,NNN	
5	PAOZZ	4730011777501	7X677	8655186	.ADAPTER,STRAIGHT,PI.....	2
					UC:BVY,B15,B20,B24,B25,C17,NNN	
6	PAHZZ	4710014608316	7X677	24200347	.TUBE,VENT.....	1
					UC:BVY,B15,B20,B24,B25,C17,NNN	
7	PAFZZ	5330014608988	7X677	8675517	.SEAL,PLAIN PART OF KIT P/N 24204441	1
					PART OF KIT P/N 24210954 PART OF KIT	
					P/N 24205251.....	
					UC:BVY,B15,B20,B24,B25,C17,NNN	
8	PAFZZ	5325014609908	7X677	8675524	.RING,RETAINING.....	1
					UC:BVY,B15,B20,B24,B25,C17,NNN	
9	PAOZZ	2990013991023	61928	24203876	.SENSOR,EGR VALVE,EM.....	2
					UC:BVY,B15,B20,B24,B25,C17,NNN	
10	PAOZZ	5306014748837	7X677	11514308	.BOLT,MACHINE.....	2
					UC:BVY,B15,B20,B24,B25,C17,NNN	
11	PAOZZ	4730011662244	81349	WW-P-471ACABUA	.PLUG,PIPE.....	1
					UC:BVY,B15,B20,B24,B25,C17,NNN	
12	PAHZZ	5306014613557	7X677	8661762	.BOLT,MACHINE PART OF KIT P/N	1
					24205251 PART OF KIT P/N 24204441...	
					UC:BVY,B15,B20,B24,B25,C17,NNN	
13	PAHZZ	5306014613557	7X677	8686124	BOLT,MACHINE PART OF KIT P/N	1
					24205251 PART OF KIT P/N 24204441...	
					UC:BVY,B15,B20,B24,B25,C17,NNN	
14	PAOZZ	5330013970374	7X677	8656613	SEAL,PLAIN ENCASED PART OF KIT P/N	1
					24202111 PART OF KIT P/N 24204441	
					PART OF KIT P/N 24210955 PART OF KIT	
					P/N 24210954 PART OF KIT P/N	
					24210956 PART OF KIT P/N 24205251...	
					UC:BVY,B15,B20,B24,B25,C17,NNN	
15	PAOZZ	2520013984589	7X677	8684221	PARTS KIT,HYDRAULIC 1995,96 PART OF	1
					KIT P/N 24202111 PART OF KIT P/N	



SECTION II			TM9-2320-280-24P			
(1)	(2)	(3)	(4)	(5)	(6)	(7)
ITEM NO	SMR CODE	NSN	CAGEC	PART NUMBER	DESCRIPTION AND USABLE ON CODES(UC)	QTY
15	KFOZZ		7X677	24210468	24204441 PART OF KIT P/N 24205251... UC:BVY,B15,B20,B24,B25,C17,NNN FILTER PART 1997,98 PART OF KIT P/N 24210955 PART OF KIT P/N 24210954 PART OF KIT P/N 24210956..... UC:BVY,B15,B20,B24,B25,C17,NNN	1
16	KFOZZ		7X677	8654701	MAGNET,CHIP COLLECT 1995,96 PART OF KIT P/N 8685921..... UC:BVY,B15,B20,B24,B25,C17,NNN	1
16	KFOZZ		7X677	8665830	MAGNET,CHIP COLLECT 1997,98 PART OF KIT P/N 24204278..... UC:BVY,B15,B20,B24,B25,C17,NNN	1
17	PAOZZ	5330013605271	7X677	8677743	GASKET..... UC:BVY,B15,B20,B24,B25,C17,NNN	1
18	KFOZZ		7X677	8682888	PAN,TRANSMISSION 1995,96 PART OF KIT P/N 8685921..... UC:BVY,B15,B20,B24,B25,C17,NNN	1
18	KFOZZ		7X677	24203377	PAN,TRANSMISSION 1997,98 PART OF KIT P/N 24204278..... UC:BVY,B15,B20,B24,B25,C17,NNN	1
19	PAOZZ	5306014652140	7X677	11515756	BOLT,MACHINE.....	17
20	PAOZZ	5305002059983	72582	116103	WASHER,FLAT 1995,96 PART OF KIT P/N 8685921..... UC:BVY,B15,B20,B24,B25,C17,NNN	1
20	PAOZZ		7X677	24205123	GASKET 1997,98 PART OF KIT P/N 24204278..... UC:BVY,B15,B20,B24,B25,C17,NNN	1
21	PAOZZ	5340014608207	7X677	8675529	PLUG,PROTECTIVE,DUS 1995,96 PART OF KIT P/N 8685921..... UC:BVY,B15,B20,B24,B25,C17,NNN	1
21	PAOZZ		7X677	24204280	PLUG,DRAIN 1997,98 PART OF KIT P/N 24204278..... UC:BVY,B15,B20,B24,B25,C17,NNN	1
22	PAHZZ	2520014612374	7X677	8661834	SCREEN,VALVE,AUTOMA..... UC:BVY,B15,B20,B24,B25,C17,NNN	1
23	PAOZZ	5340014134486	19207	12460093	COVER,ACCESS..... UC:BVY,B15,B20,B24,B25,C17,NNN	1
24	PAOZZ	5330014132118	19207	12460095	.GASKET..... UC:BVY,B15,B20,B24,B25,C17,NNN	1
25	PAOZZ	5340014123563	34623	EC-RCSK1834-3-1	.COVER,ACCESS..... UC:BVY,B15,B20,B24,B25,C17,NNN	1
26	PAOZZ	5340013145602	19207	12342107	.COVER,ACCESS..... UC:BVY,B15,B20,B24,B25,C17,NNN	1
27	PAOZZ	5330013151609	19207	12342105	.GASKET..... UC:BVY,B15,B20,B24,B25,C17,NNN	1

END OF FIGURE

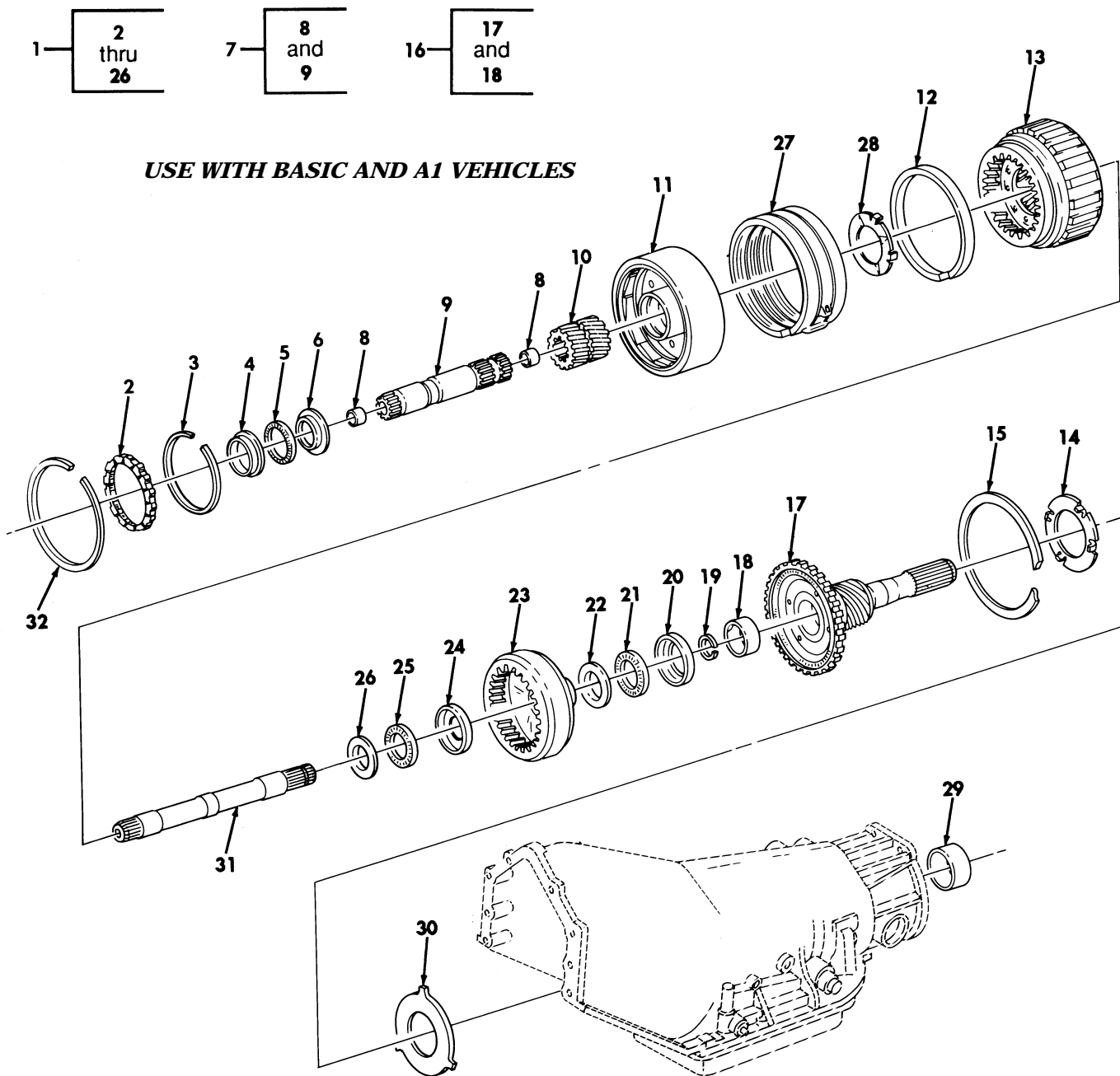

Figure 106. Planetary Gear Carrier.

SECTION II			TM9-2320-280-24P			
(1)	(2)	(3)	(4)	(5)	(6)	(7)
ITEM NO	SMR CODE	NSN	CAGEC	PART NUMBER	DESCRIPTION AND USABLE ON CODES(UOC)	QTY
GROUP 0710 TRANSMISSION ASSEMBLY						
FIG. 106 PLANETARY GEAR CARRIER						
1	XBHHH		11862	8633075	CARRIER, TRANSMISSIO..... UOC:AVY,A11,A13,A14,A15,A20,A24,A25, A26,A27,B16,B17,B18,HVY,H11,H13,H14, H15,H16,H17,H18,H20,H21,H24,H25,H26, H27,H28,MMM	1
2	PAHZZ	2520011491221	7X677	930679	.ROLLER ASSEMBLY,CLU..... UOC:AVY,A11,A13,A14,A15,A20,A24,A25, A26,A27,B16,B17,B18,HVY,H11,H13,H14, H15,H16,H17,H18,H20,H21,H24,H25,H26, H27,H28,MMM	1
3	PAHZZ	5325011548561	7X677	8627657	.RING,RETAINING..... UOC:AVY,A11,A13,A14,A15,A20,A24,A25, A26,A27,B16,B17,B18,HVY,H11,H13,H14, H15,H16,H17,H18,H20,H21,H24,H25,H26, H27,H28,MMM	1
4	KFHZZ		7X677	8623204	.RACE, BEARING PART OF KIT P/N 8623920..... UOC:AVY,A11,A13,A14,A15,A20,A24,A25, A26,A27,B16,B17,B18,HVY,H11,H13,H14, H15,H16,H17,H18,H20,H21,H24,H25,H26, H27,H28,MMM	1
5	KFHZZ		7X677	8624784	.BEARING, NEEDLE PART OF KIT P/N 8623920..... UOC:AVY,A11,A13,A14,A15,A20,A24,A25, A26,A27,B16,B17,B18,HVY,H11,H13,H14, H15,H16,H17,H18,H20,H21,H24,H25,H26, H27,H28,MMM	1
6	KFHZZ		11862	8623183	.RACE, BEARING PART OF KIT P/N 8623920..... UOC:AVY,A11,A13,A14,A15,A20,A24,A25, A26,A27,B16,B17,B18,HVY,H11,H13,H14, H15,H16,H17,H18,H20,H21,H24,H25,H26, H27,H28,MMM	1
7	PAHZZ	3040011500407	7X677	8626809	.SHAFT, STRAIGHT..... UOC:AVY,A11,A13,A14,A15,A20,A24,A25, A26,A27,B16,B17,B18,HVY,H11,H13,H14, H15,H16,H17,H18,H20,H21,H24,H25,H26, H27,H28,MMM	1
8	PAHZZ	3120011565189	7X677	8623944	..BEARING, SLEEVE..... UOC:AVY,A11,A13,A14,A15,A20,A24,A25, A26,A27,B16,B17,B18,HVY,H11,H13,H14, H15,H16,H17,H18,H20,H21,H24,H25,H26, H27,H28,MMM	2
9	XAHZZ		11862	8626806	..SHAFT..... UOC:AVY,A11,A13,A14,A15,A20,A24,A25, A26,A27,B16,B17,B18,HVY,H11,H13,H14, H15,H16,H17,H18,H20,H21,H24,H25,H26, H27,H28,MMM	1
10	PAHZZ	3020011497941	7X677	8626807	.GEAR CLUSTER.....	1

SECTION II			TM9-2320-280-24P			
(1)	(2)	(3)	(4)	(5)	(6)	(7)
ITEM NO	SMR CODE	NSN	CAGEC	PART NUMBER	DESCRIPTION AND USABLE ON CODES(UC)	QTY
11	PAHZZ	2520011497861	7X677	24205551	UOC:AVY,A11,A13,A14,A15,A20,A24,A25,A26,A27,B16,B17,B18,HVY,H11,H13,H14,H15,H16,H17,H18,H20,H21,H24,H25,H26,H27,H28,MMM .CARRIER ASSEMBLY,TR.....	1
12	PAHZZ	5325011685729	7X677	8626112	UOC:AVY,A11,A13,A14,A15,A20,A24,A25,A26,A27,B16,B17,B18,HVY,H11,H13,H14,H15,H16,H17,H18,H20,H21,H24,H25,H26,H27,H28,MMM .RING,RETAINING.....	1
13	XBHZZ		72590	8627892	UOC:AVY,A11,A13,A14,A15,A20,A24,A25,A26,A27,B16,B17,B18,HVY,H11,H13,H14,H15,H16,H17,H18,H20,H21,H24,H25,H26,H27,H28,MMM .PARTS KIT,CARRIER.....	1
14	PAHZZ	3120011547174	7X677	8626372	UOC:AVY,A11,A13,A14,A15,A20,A24,A25,A26,A27,B16,B17,B18,HVY,H11,H13,H14,H15,H16,H17,H18,H20,H21,H24,H25,H26,H27,H28,MMM .BEARING,WASHER,THRU 3.28 DIA.....	1
15	PAHZZ	5325011504982	7X677	8626173	UOC:AVY,A11,A13,A14,A15,A20,A24,A25,A26,A27,B16,B17,B18,HVY,H11,H13,H14,H15,H16,H17,H18,H20,H21,H24,H25,H26,H27,H28,MMM .RING,RETAINING.....	1
16	PAHHH	2520011681983	11862	8633059	UOC:AVY,A11,A13,A14,A15,A20,A24,A25,A26,A27,B16,B17,B18,HVY,H11,H13,H14,H15,H16,H17,H18,H20,H21,H24,H25,H26,H27,H28,MMM .SHAFT AND BUSHING A.....	1
17	XAHZZ		11862	8633056	UOC:AVY,A11,A13,A14,A15,A20,A24,A25,A26,A27,B16,B17,B18,HVY,H11,H13,H14,H15,H16,H17,H18,H20,H21,H24,H25,H26,H27,H28,MMM ..SHAFT.....	1
18	PAHZZ	3120011586304	7X677	8653985	UOC:AVY,A11,A13,A14,A15,A20,A24,A25,A26,A27,B16,B17,B18,HVY,H11,H13,H14,H15,H16,H17,H18,H20,H21,H24,H25,H26,H27,H28,MMM ..BEARING,SLEEVE.....	1
19	PAHZZ	5325011748626	7X677	8625221	UOC:AVY,A11,A13,A14,A15,A20,A24,A25,A26,A27,B16,B17,B18,HVY,H11,H13,H14,H15,H16,H17,H18,H20,H21,H24,H25,H26,H27,H28,MMM .RING,RETAINING PART OF KIT P/N 8623921.....	1
20	KFHZZ		11862	8623204	UOC:AVY,A11,A13,A14,A15,A20,A24,A25,A26,A27,B16,B17,B18,HVY,H11,H13,H14,H15,H16,H17,H18,H20,H21,H24,H25,H26,H27,H28,MMM .RACE,BEARING PART OF KIT P/N 8623922.....	1

SECTION II			TM9-2320-280-24P			
(1)	(2)	(3)	(4)	(5)	(6)	(7)
ITEM NO	SMR CODE	NSN	CAGEC	PART NUMBER	DESCRIPTION AND USABLE ON CODES(UC)	QTY
21	KFHZZ		11862	8624784	A26,A27,B16,B17,B18,HVY,H11,H13,H14,H15,H16,H17,H18,H20,H21,H24,H25,H26,H27,H28,MMM .BEARING,NEEDLE PART OF KIT P/N 8623922..... UOC:AVY,A11,A13,A14,A15,A20,A24,A25,A26,A27,B16,B17,B18,HVY,H11,H13,H14,H15,H16,H17,H18,H20,H21,H24,H25,H26,H27,H28,MMM	1
22	KFHZZ		11862	8623206	.RACE,BEARING PART OF KIT P/N 8623922..... UOC:AVY,A11,A13,A14,A15,A20,A24,A25,A26,A27,B16,B17,B18,HVY,H11,H13,H14,H15,H16,H17,H18,H20,H21,H24,H25,H26,H27,H28,MMM	1
23	PAHZZ	3020011497938	7X677	8623202	.GEAR,INTERNAL..... UOC:AVY,A11,A13,A14,A15,A20,A24,A25,A26,A27,B16,B17,B18,HVY,H11,H13,H14,H15,H16,H17,H18,H20,H21,H24,H25,H26,H27,H28,MMM	1
24	KFHZZ		7X677	8623194	.RACE,BEARING PART OF KIT P/N 8623921..... UOC:AVY,A11,A13,A14,A15,A20,A24,A25,A26,A27,B16,B17,B18,HVY,H11,H13,H14,H15,H16,H17,H18,H20,H21,H24,H25,H26,H27,H28,MMM	1
25	KFHZZ		11862	8626817	.BEARING NEEDLE PART OF KIT P/N 8623921..... UOC:AVY,A11,A13,A14,A15,A20,A24,A25,A26,A27,B16,B17,B18,HVY,H11,H13,H14,H15,H16,H17,H18,H20,H21,H24,H25,H26,H27,H28,MMM	1
26	KFHZZ		11862	8623196	.RACE,BEARING PART OF KIT P/N 8623921..... UOC:AVY,A11,A13,A14,A15,A20,A24,A25,A26,A27,B16,B17,B18,HVY,H11,H13,H14,H15,H16,H17,H18,H20,H21,H24,H25,H26,H27,H28,MMM	1
27	PAHZZ	2530011592732	11862	8681620	BAND,CLUTCH BRAKE..... UOC:AVY,A11,A13,A14,A15,A20,A24,A25,A26,A27,B16,B17,B18,HVY,H11,H13,H14,H15,H16,H17,H18,H20,H21,H24,H25,H26,H27,H28,MMM	1
28	PAHZZ	3120011547174	7X677	8626372	BEARING,WASHER,THRU 3.28 DIA..... UOC:AVY,A11,A13,A14,A15,A20,A24,A25,A26,A27,B16,B17,B18,HVY,H11,H13,H14,H15,H16,H17,H18,H20,H21,H24,H25,H26,H27,H28,MMM	1
29	PAHZZ	3120011663677	7X677	8623941	BEARING,SLEEVE..... UOC:AVY,A11,A13,A14,A15,A20,A24,A25,A26,A27,B16,B17,B18,HVY,H11,H13,H14,H15,H16,H17,H18,H20,H21,H24,H25,H26,H27,H28,MMM	1

SECTION II			TM9-2320-280-24P			
(1)	(2)	(3)	(4)	(5)	(6)	(7)
ITEM NO	SMR CODE	NSN	CAGEC	PART NUMBER	DESCRIPTION AND USABLE ON CODES(UC)	QTY
30	PAHZZ	3120011548516	7X677	8625401	BEARING,WASHER,THRU .074-.078..... UC:AVY,A11,A13,A14,A15,A20,A24,A25, A26,A27,B16,B17,B18,HVY,H11,H13,H14, H15,H16,H17,H18,H20,H21,H24,H25,H26, H27,H28,MMM	1
30	PAHZZ	3120011595773	7X677	8625402	BEARING,WASHER,THRU .082-.086..... UC:AVY,A11,A13,A14,A15,A20,A24,A25, A26,A27,B16,B17,B18,HVY,H11,H13,H14, H15,H16,H17,H18,H20,H21,H24,H25,H26, H27,H28,MMM	1
30	PAHZZ	3120011544369	7X677	8625403	BEARING,WASHER,THRU .090-.094..... UC:AVY,A11,A13,A14,A15,A20,A24,A25, A26,A27,B16,B17,B18,HVY,H11,H13,H14, H15,H16,H17,H18,H20,H21,H24,H25,H26, H27,H28,MMM	1
30	PAHZZ	3120011614033	7X677	8625404	BEARING,WASHER,THRU .098-.102..... UC:AVY,A11,A13,A14,A15,A20,A24,A25, A26,A27,B16,B17,B18,HVY,H11,H13,H14, H15,H16,H17,H18,H20,H21,H24,H25,H26, H27,H28,MMM	1
30	PAHZZ	3120011625787	7X677	8625405	BEARING,WASHER,THRU .106-.110..... UC:AVY,A11,A13,A14,A15,A20,A24,A25, A26,A27,B16,B17,B18,HVY,H11,H13,H14, H15,H16,H17,H18,H20,H21,H24,H25,H26, H27,H28,MMM	1
30	PAHZZ	3120011548517	7X677	8625406	BEARING,WASHER,THRU .114-.118..... UC:AVY,A11,A13,A14,A15,A20,A24,A25, A26,A27,B16,B17,B18,HVY,H11,H13,H14, H15,H16,H17,H18,H20,H21,H24,H25,H26, H27,H28,MMM	1
31	PAHZZ	3040011672836	7X677	8625736	SHAFT,STRAIGHT..... UC:AVY,A11,A13,A14,A15,A20,A24,A25, A26,A27,B16,B17,B18,HVY,H11,H13,H14, H15,H16,H17,H18,H20,H21,H24,H25,H26, H27,H28,MMM	1
32	PAHZZ	5325011604693	7X677	8623437	RING,RETAINING..... UC:AVY,A11,A13,A14,A15,A20,A24,A25, A26,A27,B16,B17,B18,HVY,H11,H13,H14, H15,H16,H17,H18,H20,H21,H24,H25,H26, H27,H28,MMM	1

END OF FIGURE

**USE WITH A2 VEHICLES**

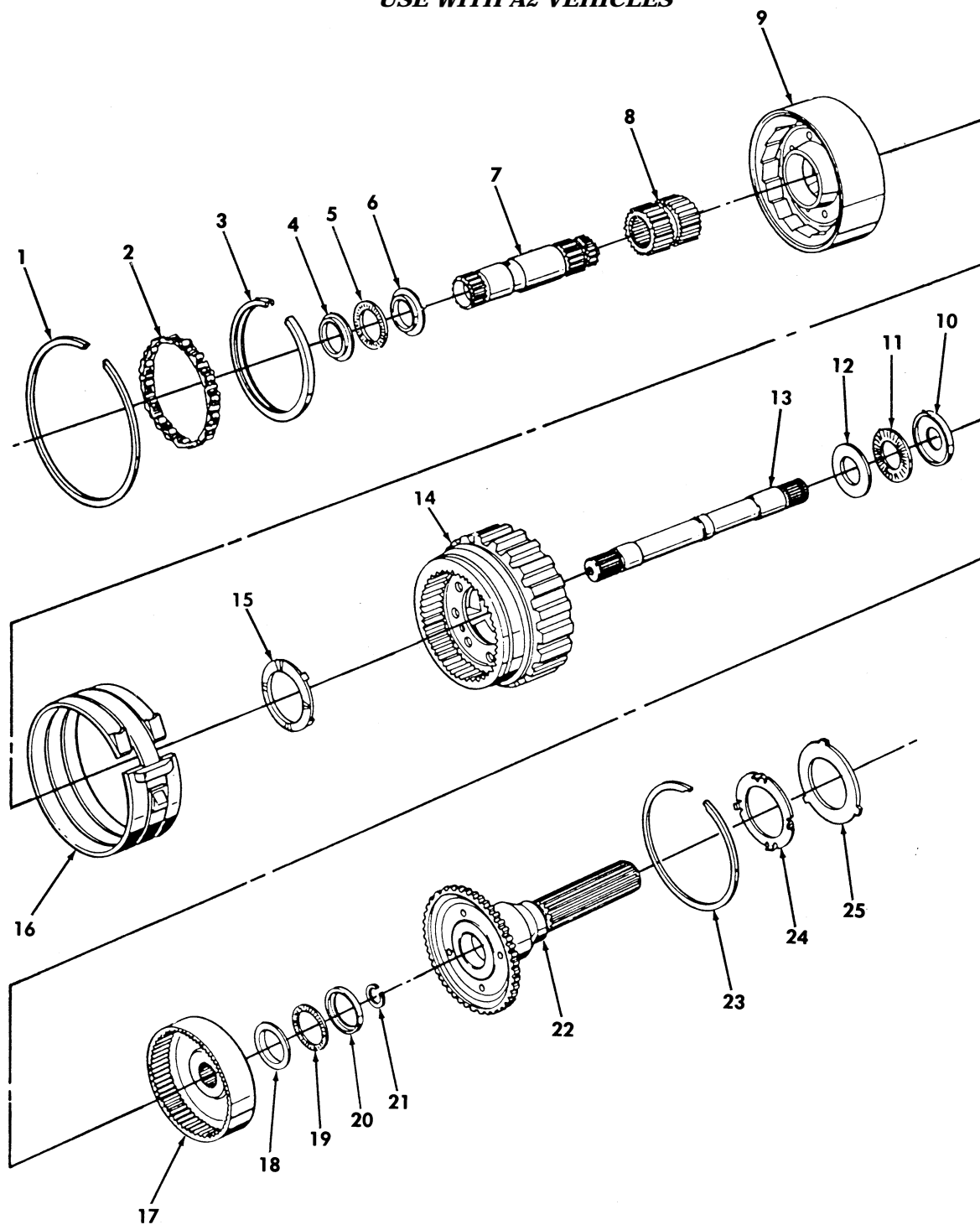

*Figure 107. Planetary Gear Carrier.*

SECTION II			TM9-2320-280-24P			
(1)	(2)	(3)	(4)	(5)	(6)	(7)
ITEM	SMR			PART		
NO	CODE	NSN	CAGEC	NUMBER	DESCRIPTION AND USABLE ON CODES(UC)	QTY
GROUP 0710 TRANSMISSION ASSEMBLY						
FIG. 107 PLANETARY GEAR CARRIER						
1	PAHZZ	5325011548562	7X677	8626816	RING,RETAINING.....	1
					UOC:BVY,B15,B20,B24,B25,C17,NNN	
2	PAHZZ	2520011491221	7X677	930679	ROLLER ASSEMBLY,CLU PART OF KIT P/N	1
					24205551 PART OF KIT P/N 24205552...	
					UOC:BVY,B15,B20,B24,B25,C17,NNN	
3	PAHZZ	5325011548561	7X677	8627657	RING,RETAINING.....	1
					UOC:BVY,B15,B20,B24,B25,C17,NNN	
4	KFHZZ		7X677	8623183	RACE,BEARING PART OF KIT P/N 8623920	1
					UOC:BVY,B15,B20,B24,B25,C17,NNN	
5	KFHZZ		7X677	8624784	BEARING,NEEDLE PART OF KIT P/N	1
					8623920.....	
					UOC:BVY,B15,B20,B24,B25,C17,NNN	
6	KFHZZ		7X677	8623204	RACE,THRUST BEARING PART OF KIT P/N	1
					8623920.....	
					UOC:BVY,B15,B20,B24,B25,C17,NNN	
7	PAHZZ	3040014473797	7X677	8661708	SHAFT,STRAIGHT 1995,96.....	1
					UOC:BVY,B15,B20,B24,B25,C17,NNN	
7	PAHZZ		7X677	24207247	SHAFT,STRAIGHT 1997,98.....	1
					UOC:BVY,B15,B20,B24,B25,C17,NNN	
8	PAHZZ	3020011497941	7X677	8626807	GEAR,HELICAL 1995,96.....	1
					UOC:BVY,B15,B20,B24,B25,C17,NNN	
8	PAHZZ		7X677	24203397	GEAR,HELICAL 1997.....	1
					UOC:BVY,B15,B20,B24,B25,C17,NNN	
8	PAHZZ		7X677	24209475	GEAR,HELICAL 1998.....	1
					UOC:BVY,B15,B20,B24,B25,C17,NNN	
9	KFHZZ		7X677	24202346	CARRIER ASSEMBLY 1995,96,97 SPUR	1
					CUT GEARS PART OF KIT P/N 24205552..	
					UOC:BVY,B15,B20,B24,B25,C17,NNN	
9	KFHZZ		7X677	24212051	CARRIER ASSEMBLY TR 1998,HELICAL	1
					CUT GEARS PART OF KIT P/N 24205551..	
					UOC:BVY,B15,B20,B24,B25,C17,NNN	
10	KFHZZ		7X677	8623196	RACE,BEARING 1995,96 PART OF KIT	1
					P/N 8623921.....	
					UOC:BVY,B15,B20,B24,B25,C17,NNN	
10	KFHZZ		7X677	24204962	RACE,BEARING 1997,98 PART OF KIT	1
					P/N 24208848.....	
					UOC:BVY,B15,B20,B24,B25,C17,NNN	
11	KFHZZ		7X677	8626817	BEARING NEEDLE PART OF KIT P/N	1
					8623921 PART OF KIT P/N 24208848....	
					UOC:BVY,B15,B20,B24,B25,C17,NNN	
12	KFHZZ		7X677	8623194	RACE,BEARING PART OF KIT P/N 8623921	1
					PART OF KIT P/N 24208848.....	
					UOC:BVY,B15,B20,B24,B25,C17,NNN	
13	PAHZZ	3040014108068	7X677	8661613	SHAFT,SHOULDERED 1995,96.....	1
					UOC:BVY,B15,B20,B24,B25,C17,NNN	
13	PAHZZ		7X677	24203400	SHAFT,SHOULDERED 1997,98.....	1
					UOC:BVY,B15,B20,B24,B25,C17,NNN	
14	PAHZZ	2520014610107	7X677	8675612	CARRIER,TRANSMISSIO 1995,96,97.....	1
					UOC:BVY,B15,B20,B24,B25,C17,NNN	



SECTION II			TM9-2320-280-24P			
(1)	(2)	(3)	(4)	(5)	(6)	(7)
ITEM NO	SMR CODE	NSN	CAGEC	PART NUMBER	DESCRIPTION AND USABLE ON CODES(UC)	QTY
14	PAHZZ		7X677	8675611	CARRIER, TRANSMISSIO 1998.....	1
					UC:BVY, B15, B20, B24, B25, C17, NNN	
15	PAHZZ	3120011547174	7X677	8626372	BEARING, WASHER, THRU.....	1
					UC:BVY, B15, B20, B24, B25, C17, NNN	
16	PAHZZ		7X677	24202229	BRAKE BAND AND LINI.....	1
					UC:BVY, B15, B20, B24, B25, C17, NNN	
17	PAHZZ		7X677	8683771	GEAR, INTERNAL 1995, 96.....	1
					UC:BVY, B15, B20, B24, B25, C17, NNN	
17	PAHZZ		7X677	24203399	GEAR, INTERNAL 1997.....	1
					UC:BVY, B15, B20, B24, B25, C17, NNN	
17	PAHZZ		7X677	24203398	GEAR, INTERNAL 1998.....	1
					UC:BVY, B15, B20, B24, B25, C17, NNN	
18	KFHZZ		7X677	8623204	RACE, THRUST BEARING PART OF KIT P/N	1
					8623922.....	
					UC:BVY, B15, B20, B24, B25, C17, NNN	
19	KFHZZ		7X677	8624784	BEARING, NEEDLE PART OF KIT P/N	1
					8623922.....	
					UC:BVY, B15, B20, B24, B25, C17, NNN	
20	KFHZZ		7X677	8623206	RACE, BEARING PART OF KIT P/N 8623922	1
					UC:BVY, B15, B20, B24, B25, C17, NNN	
21	PAHZZ	5325011748626	7X677	8625221	RING, RETAINING.....	1
					UC:BVY, B15, B20, B24, B25, C17, NNN	
22	PFHZZ	3040014108071	7X677	8661598	GEARSHAFT, SPUR 1995, 96.....	1
					UC:BVY, B15, B20, B24, B25, C17, NNN	
22	PFHZZ		7X677	24204291	GEARSHAFT, SPUR 1997, 98.....	1
					UC:BVY, B15, B20, B24, B25, C17, NNN	
23	PAHZZ	5325011504982	7X677	8626173	RING, RETAINING.....	1
					UC:BVY, B15, B20, B24, B25, C17, NNN	
24	PAHZZ	3120011547174	7X677	8626372	BEARING, WASHER, THRU.....	1
					UC:BVY, B15, B20, B24, B25, C17, NNN	
25	PAHZZ	3120011548516	7X677	8625401	BEARING, WASHER, THRU .074-.078.....	1
					UC:BVY, B15, B20, B24, B25, C17, NNN	
25	PAHZZ	3120011595773	7X677	8625402	BEARING, WASHER, THRU .082-.086.....	1
					UC:BVY, B15, B20, B24, B25, C17, NNN	
25	PAHZZ	3120011544369	7X677	8625403	BEARING, WASHER, THRU .090-.094.....	1
					UC:BVY, B15, B20, B24, B25, C17, NNN	
25	PAHZZ	3120011614033	7X677	8625404	BEARING, WASHER, THRU .098-.102.....	1
					UC:BVY, B15, B20, B24, B25, C17, NNN	
25	PAHZZ	3120011625787	7X677	8625405	BEARING, WASHER, THRU .106-.110.....	1
					UC:BVY, B15, B20, B24, B25, C17, NNN	
25	PAHZZ	3120011548517	7X677	8625406	BEARING, WASHER, THRU .114-.118.....	1
					UC:BVY, B15, B20, B24, B25, C17, NNN	

END OF FIGURE

**USE WITH A2 VEHICLES**

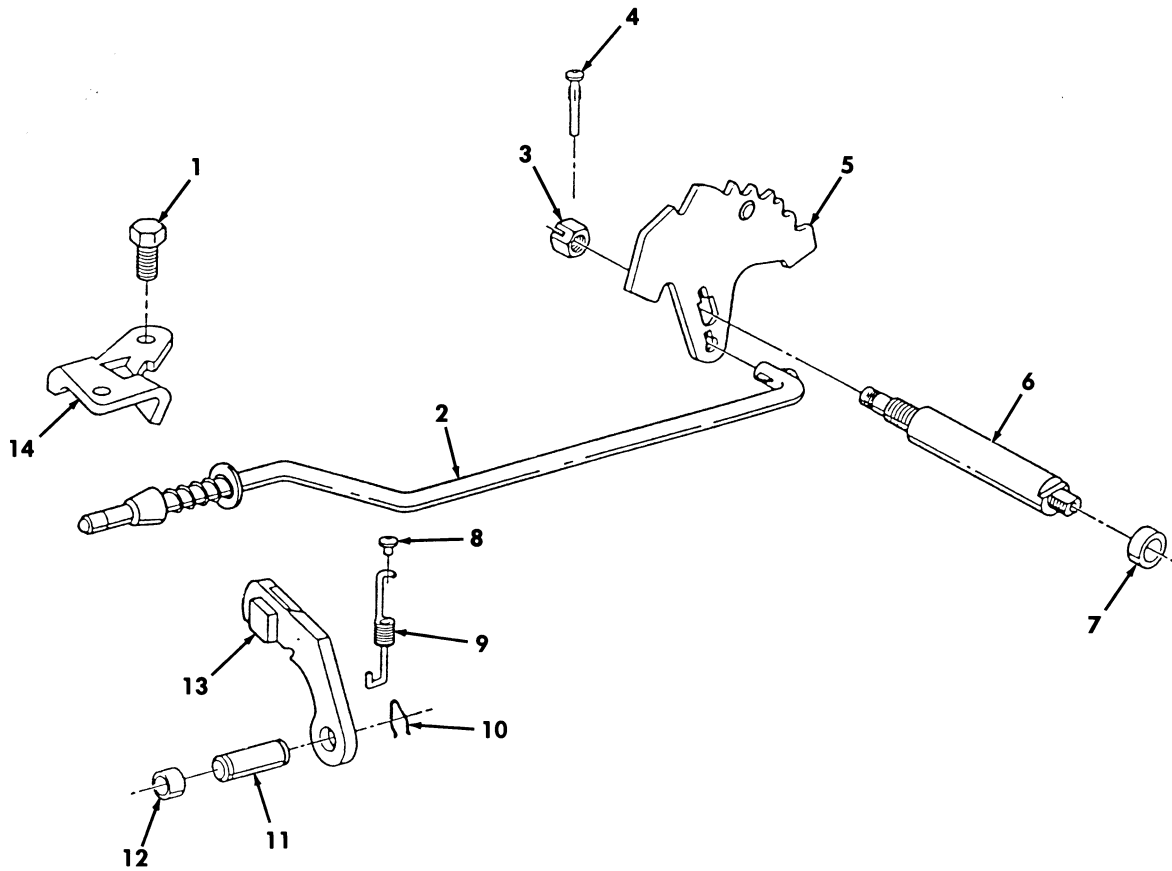
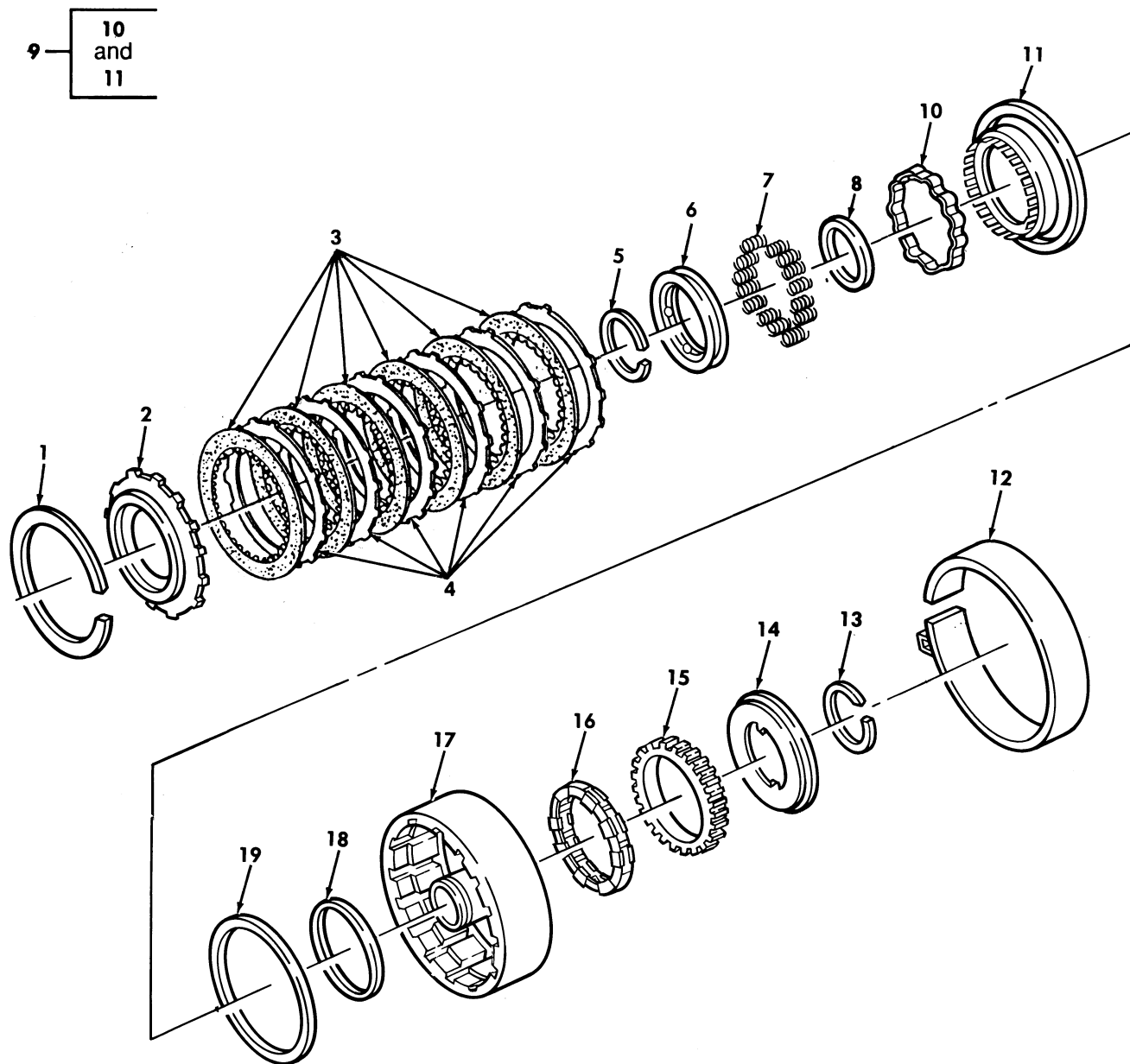

*Figure 108. Parking Lock System.*

SECTION II			TM9-2320-280-24P			
(1)	(2)	(3)	(4)	(5)	(6)	(7)
ITEM	SMR			PART		
NO	CODE	NSN	CAGEC	NUMBER	DESCRIPTION AND USABLE ON CODES(UC)	QTY
GROUP 0710 TRANSMISSION ASSEMBLY						
FIG. 108 PARKING LOCK SYSTEM						
1	PAFZZ	5306011971492	24617	11508687	BOLT,MACHINE.....	2
					UC:BVY,B15,B20,B24,B25,C17,NNN	
2	PAFZZ	3040014477995	7X677	24200173	CONNECTING LINK,RIG.....	1
					UC:BVY,B15,B20,B24,B25,C17,NNN	
3	PAFZZ	5310014470968	7X677	8648178	NUT,PLAIN,HEXAGON.....	1
					UC:BVY,B15,B20,B24,B25,C17,NNN	
4	PAFZZ	5315014470492	7X677	8678347	PIN,STRAIGHT,HEADLE.....	1
					UC:BVY,B15,B20,B24,B25,C17,NNN	
5	KFFZZ		7X677	24201001	LEVER,REMOTE CONTRO PART OF KIT P/N	1
					24204472.....	
					UC:BVY,B15,B20,B24,B25,C17,NNN	
6	KFFZZ		7X677	24200999	SHAFT PART OF KIT P/N 24204472.....	1
					UC:BVY,B15,B20,B24,B25,C17,NNN	
7	PAFZZ	5330012511607	7X677	8657163	GASKET PART OF KIT P/N 24202111 PART	1
					OF KIT P/N 24204441 PART OF KIT P/N	
					24205251 PART OF KIT P/N 24210955	
					PART OF KIT P/N 24210956.....	
					UC:BVY,B15,B20,B24,B25,C17,NNN	
8	PAFZZ	5315014088020	7X677	8678122	PIN,STRAIGHT,HEADED.....	1
					UC:BVY,B15,B20,B24,B25,C17,NNN	
9	PAFZZ	5360014614931	7X677	24202611	SPRING,HELICAL,EXTE.....	1
					UC:BVY,B15,B20,B24,B25,C17,NNN	
10	PAFZZ	5340011625883	24617	451786	CLIP,RETAINING.....	1
					UC:BVY,B15,B20,B24,B25,C17,NNN	
11	PAFZZ	5315014609907	7X677	8661692	PIN,STRAIGHT,HEADLE.....	1
					UC:BVY,B15,B20,B24,B25,C17,NNN	
12	PAFZZ	4730014605520	7X677	24200224	PLUG,PIPE.....	1
					UC:BVY,B15,B20,B24,B25,C17,NNN	
13	PAFZZ	3040014609964	7X677	8661693	PAWL.....	1
					UC:BVY,B15,B20,B24,B25,C17,NNN	
14	PAFZZ	4710014608316	7X677	24200347	BRACKET.....	1
					UC:BVY,B15,B20,B24,B25,C17,NNN	

END OF FIGURE

**USE WITH BASIC AND A1 VEHICLES**



*Figure 109. Direct Clutch Assembly.*

SECTION II			TM9-2320-280-24P			
(1)	(2)	(3)	(4)	(5)	(6)	(7)
ITEM	SMR			PART		
NO	CODE	NSN	CAGEC	NUMBER	DESCRIPTION AND USABLE ON CODES(UC)	QTY
GROUP 0713 INTERMEDIATE CLUTCH						
FIG. 109 DIRECT CLUTCH ASSEMBLY						
1	PAHZZ	5325000073052	7X677	8623112	RING,RETAINING..... UOC:AVY,A11,A13,A14,A15,A20,A24,A25, A26,A27,B16,B17,B18,HVY,H11,H13,H14, H15,H16,H17,H18,H20,H21,H24,H25,H26, H27,H28,MMM	1
2	PAHZZ	2520000089987	73342	23017763	PRESSURE PLATE ASSE..... UOC:AVY,A11,A13,A14,A15,A20,A24,A25, A26,A27,B16,B17,B18,HVY,H11,H13,H14, H15,H16,H17,H18,H20,H21,H24,H25,H26, H27,H28,MMM	1
3	KFHZZ		7X677	24202646	DISK,CLUTCH PART OF KIT P/N 8629955 PART OF KIT P/N 24205251..... UOC:AVY,A11,A13,A14,A15,A20,A24,A25, A26,A27,B16,B17,B18,HVY,H11,H13,H14, H15,H16,H17,H18,H20,H21,H24,H25,H26, H27,H28,MMM	6
4	PAHZZ	2520001721947	73342	29530330	DISK,CLUTCH .0915..... UOC:AVY,A11,A13,A14,A15,A20,A24,A25, A26,A27,B16,B17,B18,HVY,H11,H13,H14, H15,H16,H17,H18,H20,H21,H24,H25,H26, H27,H28,MMM	6
5	PAHZZ	5325011713392	73342	6884730	RING,RETAINING 1.63 X .062..... UOC:AVY,A11,A13,A14,A15,A20,A24,A25, A26,A27,B16,B17,B18,HVY,H11,H13,H14, H15,H16,H17,H18,H20,H21,H24,H25,H26, H27,H28,MMM	1
6	PAHZZ	3110000050873	11862	8623104	PLATE,RETAINING,BEA..... UOC:AVY,A11,A13,A14,A15,A20,A24,A25, A26,A27,B16,B17,B18,HVY,H11,H13,H14, H15,H16,H17,H18,H20,H21,H24,H25,H26, H27,H28,MMM	1
7	PAHZZ	5360011506091	7X677	8624101	SPRING,HELICAL,COMP..... UOC:AVY,A11,A13,A14,A15,A20,A24,A25, A26,A27,B16,B17,B18,HVY,H11,H13,H14, H15,H16,H17,H18,H20,H21,H24,H25,H26, H27,H28,MMM	14
8	KFHZZ		7X677	8623102	SEAL PART OF KIT P/N 8629955..... UOC:AVY,A11,A13,A14,A15,A20,A24,A25, A26,A27,B16,B17,B18,HVY,H11,H13,H14, H15,H16,H17,H18,H20,H21,H24,H25,H26, H27,H28,MMM	1
9	PFHZZ	2520011921260	7X677	8670201	RING,TRANSMISSION..... UOC:AVY,A11,A13,A14,A15,A20,A24,A25, A26,A27,B16,B17,B18,HVY,H11,H13,H14, H15,H16,H17,H18,H20,H21,H24,H25,H26, H27,H28,MMM	1
10	XAHZZ		7X677	8627422	.RING,APPLY..... UOC:AVY,A11,A13,A14,A15,A20,A24,A25, A26,A27,B16,B17,B18,HVY,H11,H13,H14,	1

SECTION II			TM9-2320-280-24P			
(1)	(2)	(3)	(4)	(5)	(6)	(7)
ITEM NO	SMR CODE	NSN	CAGEC	PART NUMBER	DESCRIPTION AND USABLE ON CODES(UOC)	QTY
11	PAHZZ	2520011637866	7X677	8670200	H15,H16,H17,H18,H20,H21,H24,H25,H26, H27,H28,MMM .PARTS KIT,TRANSMISS.....	1
					UOC:AVY,A11,A13,A14,A15,A20,A24,A25, A26,A27,B16,B17,B18,HVY,H11,H13,H14, H15,H16,H17,H18,H20,H21,H24,H25,H26, H27,H28,MMM	
12	PAHZZ	2520012126642	7X677	8675578	BAND,CLUTCH,FRONT.....	1
					UOC:AVY,A11,A13,A14,A15,A20,A24,A25, A26,A27,B16,B17,B18,HVY,H11,H13,H14, H15,H16,H17,H18,H20,H21,H24,H25,H26, H27,H28,MMM	
13	PAHZZ	5325011506092	7X677	8623120	RING,RETAINING 2.40 X .042.....	1
					UOC:AVY,A11,A13,A14,A15,A20,A24,A25, A26,A27,B16,B17,B18,HVY,H11,H13,H14, H15,H16,H17,H18,H20,H21,H24,H25,H26, H27,H28,MMM	
14	KFHZZ		7X677	8627334	DISK,CLUTCH,VEHICUL PART OF KIT P/N 8680915.....	1
					UOC:AVY,A11,A13,A14,A15,A20,A24,A25, A26,A27,B16,B17,B18,HVY,H11,H13,H14, H15,H16,H17,H18,H20,H21,H24,H25,H26, H27,H28,MMM	
15	PAHZZ	3110011554438	7X677	8629487	RING,BEARING,OUTER.....	1
					UOC:AVY,A11,A13,A14,A15,A20,A24,A25, A26,A27,B16,B17,B18,HVY,H11,H13,H14, H15,H16,H17,H18,H20,H21,H24,H25,H26, H27,H28,MMM	
16	PAHZZ	3110011748136	7X677	8623116	BEARING,ROLLER,NEED.....	1
					UOC:AVY,A11,A13,A14,A15,A20,A24,A25, A26,A27,B16,B17,B18,HVY,H11,H13,H14, H15,H16,H17,H18,H20,H21,H24,H25,H26, H27,H28,MMM	
17	PAHZZ	3040012662122	7X677	8679960	HOUSING,MECHANICAL.....	1
					UOC:AVY,A11,A13,A14,A15,A20,A24,A25, A26,A27,B16,B17,B18,HVY,H11,H13,H14, H15,H16,H17,H18,H20,H21,H24,H25,H26, H27,H28,MMM	
18	KFHZZ		7X677	8623121	SEAL PART OF KIT P/N 8629955.....	1
					UOC:AVY,A11,A13,A14,A15,A20,A24,A25, A26,A27,B16,B17,B18,HVY,H11,H13,H14, H15,H16,H17,H18,H20,H21,H24,H25,H26, H27,H28,MMM	
19	KFHZZ		7X677	8623101	SEAL PART OF KIT P/N 8629955.....	1
					UOC:AVY,A11,A13,A14,A15,A20,A24,A25, A26,A27,B16,B17,B18,HVY,H11,H13,H14, H15,H16,H17,H18,H20,H21,H24,H25,H26, H27,H28,MMM	

END OF FIGURE

12—  
13  
and  
14

**USE WITH A2 VEHICLES**

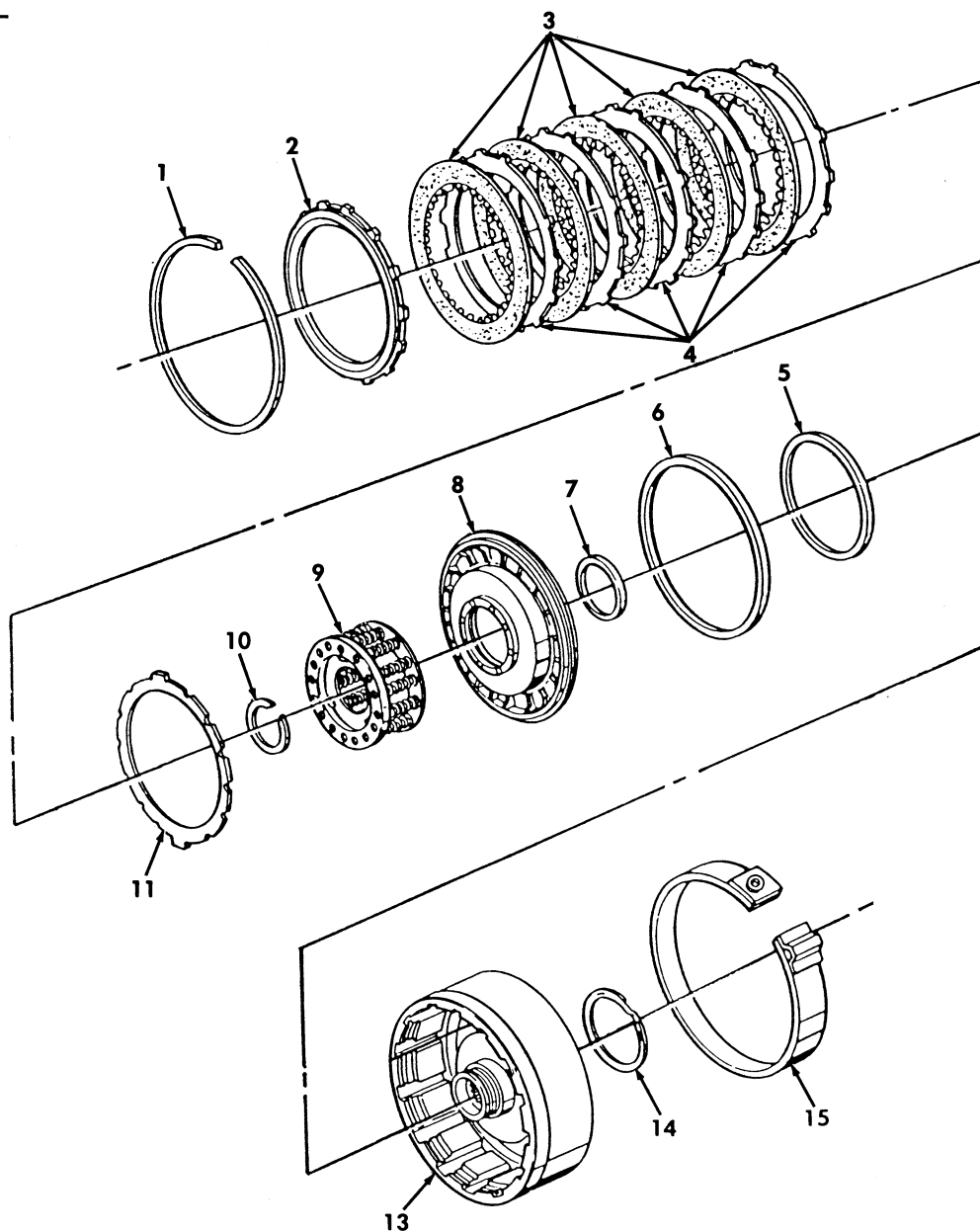

Figure 110. Direct Clutch Assembly.

SECTION II			TM9-2320-280-24P			
(1)	(2)	(3)	(4)	(5)	(6)	(7)
ITEM NO	SMR CODE	NSN	CAGEC	PART NUMBER	DESCRIPTION AND USABLE ON CODES(UOC)	QTY
GROUP 0713 INTERMEDIATE CLUTCH						
FIG. 110 DIRECT CLUTCH ASSEMBLY						
1	PAHZZ	5325000073052	7X677	8623112	RING,RETAINING.....	1
					UOC:BVY,B15,B20,B24,B25,C17,NNN	
2	PAHZZ	2520014610076	7X677	8675557	RETAINER,CLUTCH PLA.....	1
					UOC:BVY,B15,B20,B24,B25,C17,NNN	
3	PAHZZ	2520011503932	7X677	24202646	DISK,CLUTCH PART OF KIT P/N 24204441	5
					PART OF KIT P/N 24205251 PART OF KIT P/N 24210954.....	
					UOC:BVY,B15,B20,B24,B25,C17,NNN	
4	PAHZZ	2520001721947	73342	29530330	DISK,CLUTCH.....	5
					UOC:BVY,B15,B20,B24,B25,C17,NNN	
5	KFHZZ		24617	24209225	SEAL,DIRECT CLUTCH PART OF KIT P/N 24204441	1
					PART OF KIT P/N 24205251 PART OF KIT P/N 24210954.....	
					UOC:BVY,B15,B20,B24,B25,C17,NNN	
6	KFHZZ		24617	8677483	SEAL,PISTON,OUTER 1995,96 PART OF KIT 24204441	1
					PART OF KIT P/N 24205251.....	
					UOC:BVY,B15,B20,B24,B25,C17,NNN	
7	KFHZZ		7X677	8677582	SEAL,PISTON,INNER 1995,96 PART OF KIT P/N 24204441	1
					PART OF KIT 24205251.....	
					UOC:BVY,B15,B20,B24,B25,C17,NNN	
8	PAHZZ	2520014135540	61928	8675511	PISTON,CLUTCH SHAFT 1995,96.....	1
					UOC:BVY,B15,B20,B24,B25,C17,NNN	
8	PAHZZ		7X677	24209311	PISTON,CLUTCH SHAFT 1997,98.....	1
					UOC:BVY,B15,B20,B24,B25,C17,NNN	
9	PAHZZ	2520014610099	7X677	8661764	SPRING AND RETAINER.....	1
					UOC:BVY,B15,B20,B24,B25,C17,NNN	
10	PAHZZ	5325011713392	7X677	8623105	RING,RETAINING.....	1
					UOC:BVY,B15,B20,B24,B25,C17,NNN	
11	PAHZZ	2520013928435	61928	8680816	DISK,CLUTCH 1995,96.....	1
					UOC:BVY,B15,B20,B24,B25,C17,NNN	
11	PAHZZ		7X677	24205560	DISK,CLUTCH 1997,98.....	1
					UOC:BVY,B15,B20,B24,B25,C17,NNN	
12	PAHZZ		7X677	24209311	CLUTCH ASSEMBLY,FRI.....	1
					UOC:BVY,B15,B20,B24,B25,C17,NNN	
13	XAHZZ		7X677	24209244	.HOUSING,DIRECT CLUT.....	1
					UOC:BVY,B15,B20,B24,B25,C17,NNN	
14	PAHZZ	5340014760352	7X677	8675558	.RING,RETAINING PART OF KIT P/N 8680915.....	1
					UOC:BVY,B15,B20,B24,B25,C17,NNN	
15	PAHZZ		7X677	24202631	BAND,CLUTCH,FRONT.....	1
					UOC:BVY,B15,B20,B24,B25,C17,NNN	

END OF FIGURE



**USE WITH BASIC AND A1 VEHICLES**

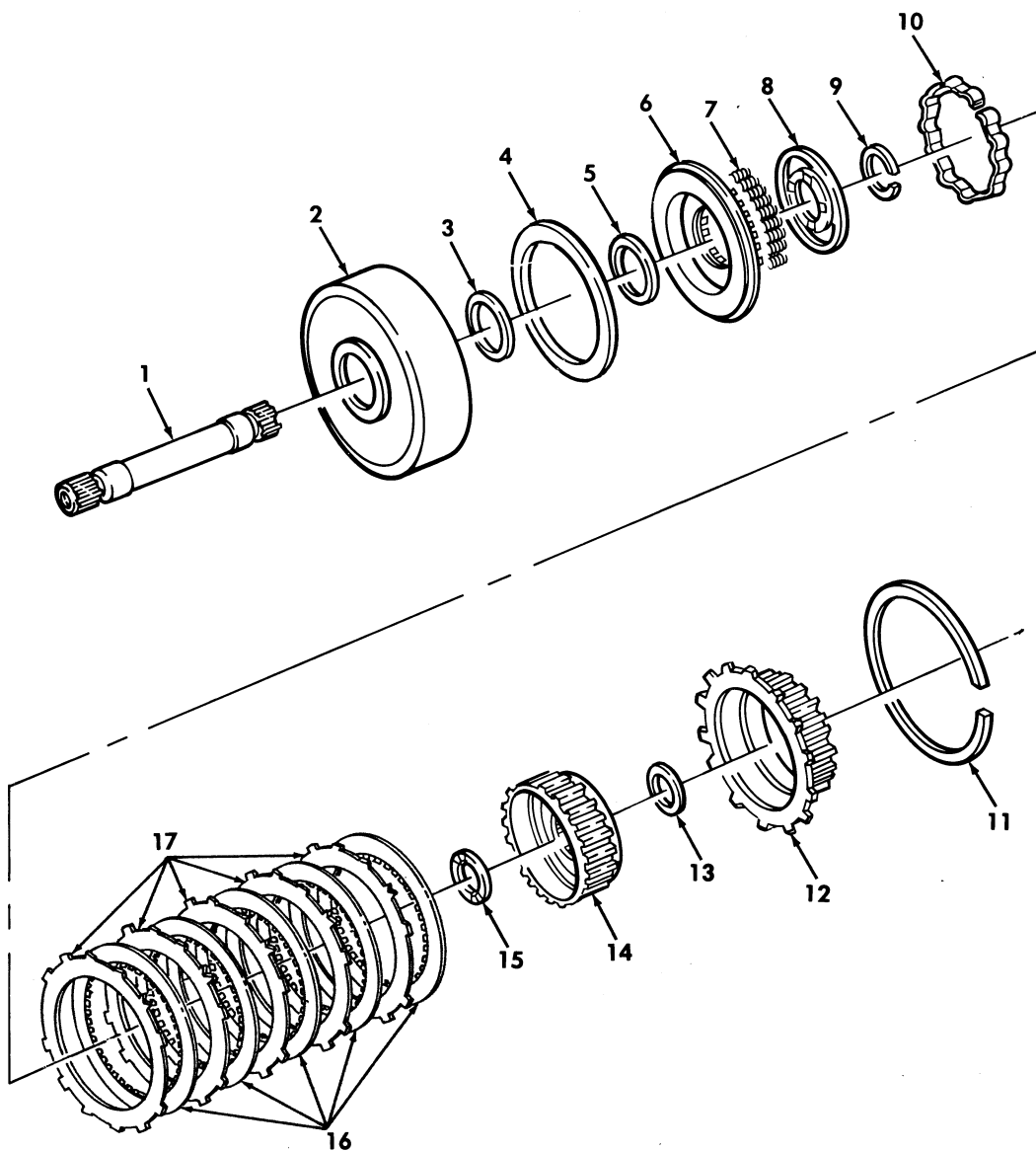
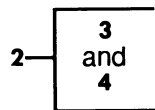

Figure 111. Forward Clutch.

SECTION II			TM9-2320-280-24P			
(1)	(2)	(3)	(4)	(5)	(6)	(7)
ITEM	SMR			PART		
NO	CODE	NSN	CAGEC	NUMBER	DESCRIPTION AND USABLE ON CODES(UOC)	QTY
GROUP 0713 INTERMEDIATE CLUTCH						
FIG. 111 FORWARD CLUTCH						
1	PAHZZ	3040011496706	7X677	8624772	SHAFT, STRAIGHT.....	1
					UOC:AVY,A11,A13,A14,A15,A20,A24,A25, A26,A27,B16,B17,B18,HVY,H11,H13,H14, H15,H16,H17,H18,H20,H21,H24,H25,H26, H27,H28,MMM	
2	PAHZZ	2520011697674	7X677	8624908	PARTS KIT,CLUTCH,HO.....	1
					UOC:AVY,A11,A13,A14,A15,A20,A24,A25, A26,A27,B16,B17,B18,HVY,H11,H13,H14, H15,H16,H17,H18,H20,H21,H24,H25,H26, H27,H28,MMM	
3	KFHZZ		73342	23015880	SEAL,PLAIN PART OF KIT P/N 8623917..	1
					UOC:AVY,A11,A13,A14,A15,A20,A24,A25, A26,A27,B16,B17,B18,HVY,H11,H13,H14, H15,H16,H17,H18,H20,H21,H24,H25,H26, H27,H28,MMM	
4	PAHZZ	5330000014904	73342	3947086	SEAL,OUTER PART OF KIT P/N 8623917..	1
					UOC:AVY,A11,A13,A14,A15,A20,A24,A25, A26,A27,B16,B17,B18,HVY,H11,H13,H14, H15,H16,H17,H18,H20,H21,H24,H25,H26, H27,H28,MMM	
5	PAHZZ	2840000014903	63005	8623102	SEAL AIR,AIRCRAFT G PART OF KIT P/N	1
					8623917.....	
					UOC:AVY,A11,A13,A14,A15,A20,A24,A25, A26,A27,B16,B17,B18,HVY,H11,H13,H14, H15,H16,H17,H18,H20,H21,H24,H25,H26, H27,H28,MMM	
6	PAHZZ	2520011637866	7X677	8670200	PARTS KIT,TRANSMISS PART OF KIT P/N	1
					8627989.....	
					UOC:AVY,A11,A13,A14,A15,A20,A24,A25, A26,A27,B16,B17,B18,HVY,H11,H13,H14, H15,H16,H17,H18,H20,H21,H24,H25,H26, H27,H28,MMM	
7	PAOZZ	5360011506091	7X677	8624101	SPRING,HELICAL,COMP.....	16
					UOC:AVY,A11,A13,A14,A15,A20,A24,A25, A26,A27,B16,B17,B18,HVY,H11,H13,H14, H15,H16,H17,H18,H20,H21,H24,H25,H26, H27,H28,MMM	
8	PAHZZ	3110000050873	11862	8623104	PLATE,RETAINING,BEA.....	1
					UOC:AVY,A11,A13,A14,A15,A20,A24,A25, A26,A27,B16,B17,B18,HVY,H11,H13,H14, H15,H16,H17,H18,H20,H21,H24,H25,H26, H27,H28,MMM	
9	PAHZZ	5325011713392	73342	6884730	RING,RETAINING 1.630 X .062.....	1
					UOC:AVY,A11,A13,A14,A15,A20,A24,A25, A26,A27,B16,B17,B18,HVY,H11,H13,H14, H15,H16,H17,H18,H20,H21,H24,H25,H26, H27,H28,MMM	
10	PAHZZ	2520011502279	7X677	8679940	DISK,CLUTCH,VEHICUL PART OF KIT P/N	1
					8627989.....	
					UOC:AVY,A11,A13,A14,A15,A20,A24,A25,	

SECTION II			TM9-2320-280-24P			
(1)	(2)	(3)	(4)	(5)	(6)	(7)
ITEM	SMR			PART		
NO	CODE	NSN	CAGEC	NUMBER	DESCRIPTION AND USABLE ON CODES(UOC)	QTY
11	PAHZZ	5325000073052	7X677	8623112	A26,A27,B16,B17,B18,HVY,H11,H13,H14, H15,H16,H17,H18,H20,H21,H24,H25,H26, H27,H28,MMM RING,RETAINING 6.24 OD X .062.....	1
12	PAHZZ	2520011709826	73342	23015732	UOC:AVY,A11,A13,A14,A15,A20,A24,A25, A26,A27,B16,B17,B18,HVY,H11,H13,H14, H15,H16,H17,H18,H20,H21,H24,H25,H26, H27,H28,MMM HUB,CLUTCH,DRIVING.....	1
13	PAHZZ	3120002555697	7X677	8624781	UOC:AVY,A11,A13,A14,A15,A20,A24,A25, A26,A27,B16,B17,B18,HVY,H11,H13,H14, H15,H16,H17,H18,H20,H21,H24,H25,H26, H27,H28,MMM BEARING,WASHER,THRU.....	1
14	PAHZZ	3020011495049	7X677	8625717	UOC:AVY,A11,A13,A14,A15,A20,A24,A25, A26,A27,B16,B17,B18,HVY,H11,H13,H14, H15,H16,H17,H18,H20,H21,H24,H25,H26, H27,H28,MMM GEAR,SPUR.....	1
15	PAHZZ	3120011568763	7X677	8624196	UOC:AVY,A11,A13,A14,A15,A20,A24,A25, A26,A27,B16,B17,B18,HVY,H11,H13,H14, H15,H16,H17,H18,H20,H21,H24,H25,H26, H27,H28,MMM BEARING,WASHER,THRU.....	1
16	PAHZZ	2520011503932	7X677	24202646	UOC:AVY,A11,A13,A14,A15,A20,A24,A25, A26,A27,B16,B17,B18,HVY,H11,H13,H14, H15,H16,H17,H18,H20,H21,H24,H25,H26, H27,H28,MMM DISK,CLUTCH.....	5
17	PAHZZ	2520001721947	73342	29530330	UOC:AVY,A11,A13,A14,A15,A20,A24,A25, A26,A27,B16,B17,B18,HVY,H11,H13,H14, H15,H16,H17,H18,H20,H21,H24,H25,H26, H27,H28,MMM DISK,CLUTCH .0713.....	5

END OF FIGURE



**USE WITH A2 VEHICLES**

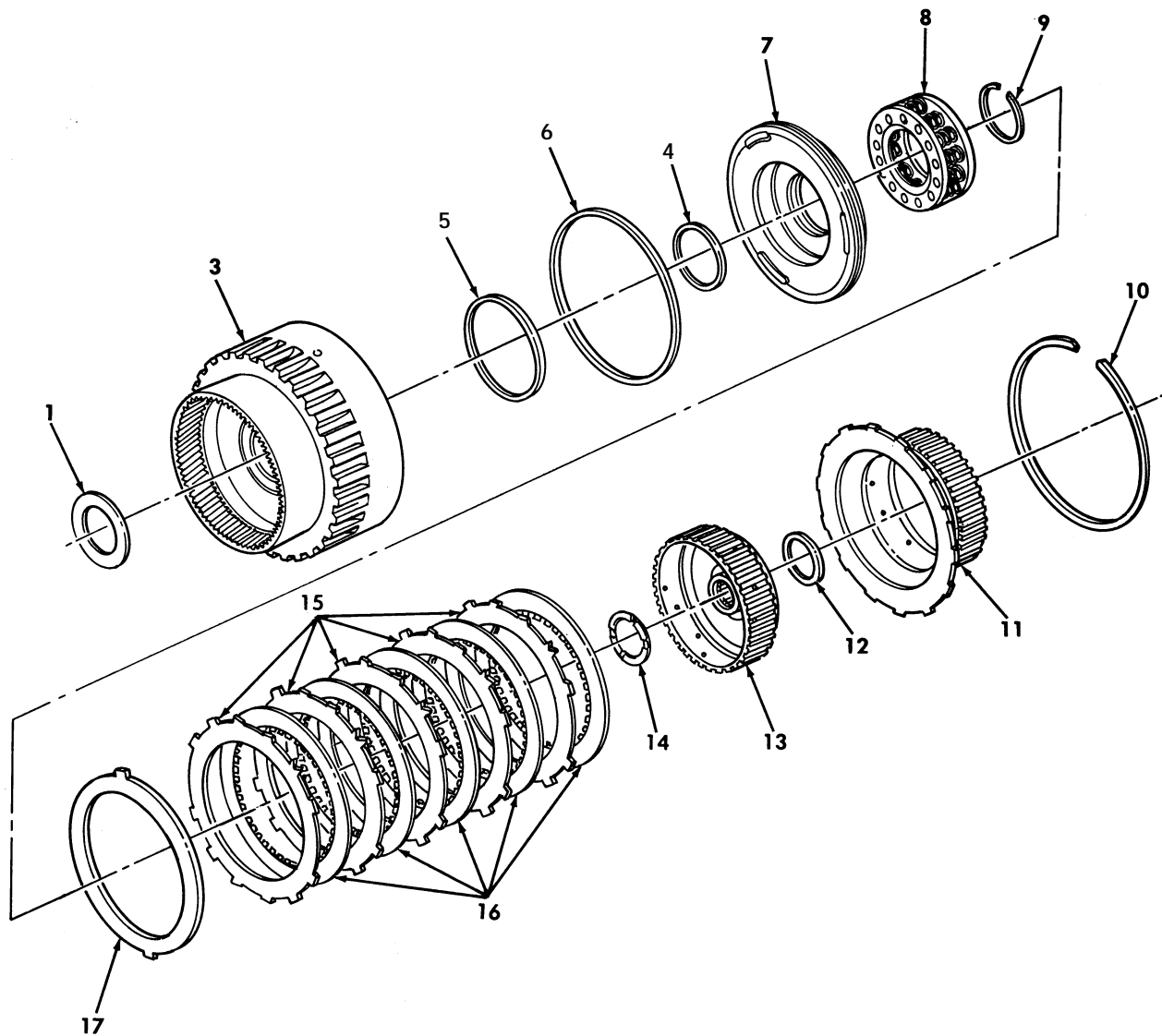

*Figure 112. Forward Clutch.*

SECTION II			TM9-2320-280-24P			
(1)	(2)	(3)	(4)	(5)	(6)	(7)
ITEM	SMR			PART		
NO	CODE	NSN	CAGEC	NUMBER	DESCRIPTION AND USABLE ON CODES(UC)	QTY
GROUP 0713 INTERMEDAITE CLUTCH						
FIG. 112 FORWARD CLUTCH						
1	PAHZZ		7X677	8628202	BEARING,WASHER,THRU.....	1
					UC:BVY,B15,B20,B24,B25,C17,NNN	
2	PAHZZ		7X677	24208850	HOUSING PART,TRANSM.....	1
					UC:BVY,B15,B20,B24,B25,C17,NNN	
3	XAHZZ		7X677	24203499	.HOUSING,FORWARD CLU.....	1
					UC:BVY,B15,B20,B24,B25,C17,NNN	
4	KFHZZ		7X677	8677582	.SEAL,INNER 1995,96 PART OF KIT P/N	1
					24204441 PART OF KIT P/N 24205251...	
					UC:BVY,B15,B20,B24,B25,C17,NNN	
4	KFHZZ		7X677	24207501	.SEAL,INNER 1997,98 PART OF KIT P/N	1
					24210954.....	
					UC:BVY,B15,B20,B24,B25,C17,NNN	
5	KFHZZ		7X677	24202359	SEAL,INNER 1995,96 PART OF KIT P/N	1
					24204441 PART OF KIT P/N 24205251...	
					UC:BVY,B15,B20,B24,B25,C17,NNN	
6	KFHZZ		7X677	8677583	SEAL,OUTER 1995,96 PART OF KIT P/N	1
					24204441 PART OF KIT P/N 24205251...	
					UC:BVY,B15,B20,B24,B25,C17,NNN	
7	PAHZZ		7X677	8675508	PISTON,LINEAR ACTUA 1995,96.....	1
					UC:BVY,B15,B20,B24,B25,C17,NNN	
7	PAHZZ		7X677	24204957	PISTON,LINEAR ACTUA 1997,98.....	1
					UC:BVY,B15,B20,B24,B25,C17,NNN	
8	PAHZZ	2520014610099	7X677	8661764	SPRING AND RETAINER.....	1
					UC:BVY,B15,B20,B24,B25,C17,NNN	
9	PAHZZ	5325011713392	7X677	8623105	RING,RETAINING.....	1
					UC:BVY,B15,B20,B24,B25,C17,NNN	
10	PAHZZ	5325000073052	7X677	8623112	RING,RETAINING 6.24 X .062.....	1
					UC:BVY,B15,B20,B24,B25,C17,NNN	
11	PAHZZ		7X677	8661837	HUB,BODY.....	1
					UC:BVY,B15,B20,B24,B25,C17,NNN	
12	PAHZZ	3120002555697	7X677	8624781	BEARING,WASHER,THRU.....	1
					UC:BVY,B15,B20,B24,B25,C17,NNN	
13	PAHZZ		7X677	8677091	GEAR,SPUR.....	1
					UC:BVY,B15,B20,B24,B25,C17,NNN	
14	PAHZZ	3120011568763	7X677	8624196	BEARING,WASHER,THRU.....	1
					UC:BVY,B15,B20,B24,B25,C17,NNN	
15	PAHZZ	2520011503931	7X677	8623849	DISK,CLUTCH,VEHICUL.....	5
					UC:BVY,B15,B20,B24,B25,C17,NNN	
16	PAHZZ	2520011503932	7X677	24202646	DISK,CLUTCH PART OF KIT P/N 24204441	5
					PART OF KIT P/N 24205251 PART OF KIT	
					P/N 24210954.....	
					UC:BVY,B15,B20,B24,B25,C17,NNN	
17	PAHZZ	2520013928435	61982	8680816	DISK,CLUTCH 1995,96.....	1
					UC:BVY,B15,B20,B24,B25,C17,NNN	
17	PAHZZ		7X677	24205560	DISK,CLUTCH 1997,98.....	1
					UC:BVY,B15,B20,B24,B25,C17,NNN	

END OF FIGURE

**USE WITH BASIC AND A1 VEHICLES**

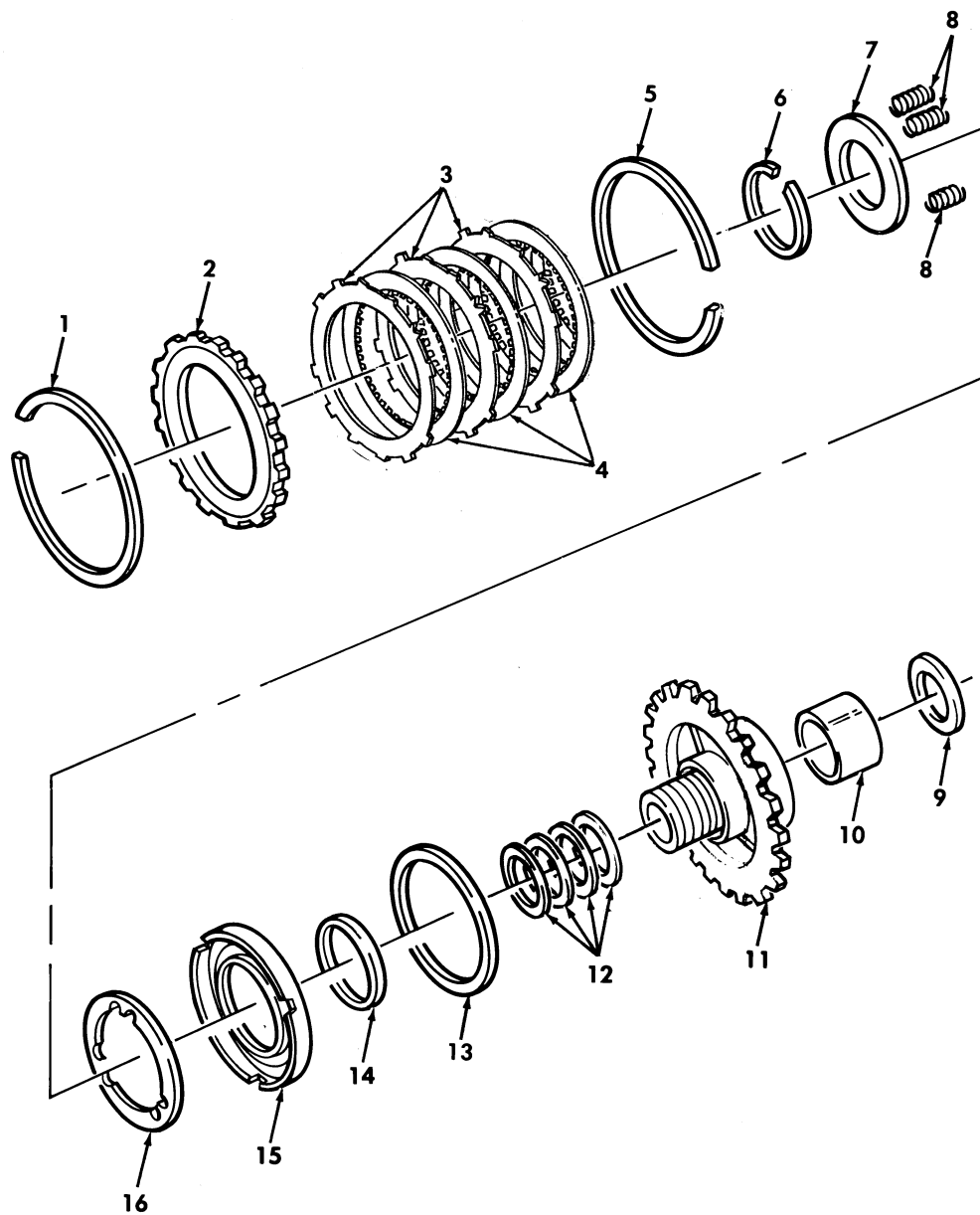

Figure 113. Intermediate Clutch and Center Support Assembly.

SECTION II			TM9-2320-280-24P			
(1)	(2)	(3)	(4)	(5)	(6)	(7)
ITEM	SMR			PART		
NO	CODE	NSN	CAGEC	NUMBER	DESCRIPTION AND USABLE ON CODES(UC)	QTY
GROUP 0713 INTERMEDIATE CLUTCH						
FIG. 113 INTERMEDIATE CLUTCH AND CENTER SUPPORT ASSEMBLY						
1	PAHZZ	5325011507830	7X677	8623149	RING,RETAINING..... UOC:AVY,A11,A13,A14,A15,A20,A24,A25, A26,A27,B16,B17,B18,HVY,H11,H13,H14, H15,H16,H17,H18,H20,H21,H24,H25,H26, H27,H28,MMM	1
2	PAHZZ	2520011756492	7X677	8623152	DISK,CLUTCH,VEHICUL..... UOC:AVY,A11,A13,A14,A15,A20,A24,A25, A26,A27,B16,B17,B18,HVY,H11,H13,H14, H15,H16,H17,H18,H20,H21,H24,H25,H26, H27,H28,MMM	1
3	PAHZZ	2520011507609	7X677	8623151	DISK,CLUTCH,VEHICUL..... UOC:AVY,A11,A13,A14,A15,A20,A24,A25, A26,A27,B16,B17,B18,HVY,H11,H13,H14, H15,H16,H17,H18,H20,H21,H24,H25,H26, H27,H28,MMM	3
4	PAHZZ	2520011682060	72590	8680938	PRESSURE PLATE ASSE..... UOC:AVY,A11,A13,A14,A15,A20,A24,A25, A26,A27,B16,B17,B18,HVY,H11,H13,H14, H15,H16,H17,H18,H20,H21,H24,H25,H26, H27,H28,MMM	3
5	PAHZZ	5325011604693	7X677	8623437	RING,RETAINING..... UOC:AVY,A11,A13,A14,A15,A20,A24,A25, A26,A27,B16,B17,B18,HVY,H11,H13,H14, H15,H16,H17,H18,H20,H21,H24,H25,H26, H27,H28,MMM	1
6	PAHZZ	5325011582182	7X677	8623153	RING,RETAINING..... UOC:AVY,A11,A13,A14,A15,A20,A24,A25, A26,A27,B16,B17,B18,HVY,H11,H13,H14, H15,H16,H17,H18,H20,H21,H24,H25,H26, H27,H28,MMM	1
7	PAHZZ	2520011502280	7X677	8623146	DISK,CLUTCH,VEHICUL INTERMEDIATE CLUTCH SPRING..... UOC:AVY,A11,A13,A14,A15,A20,A24,A25, A26,A27,B16,B17,B18,HVY,H11,H13,H14, H15,H16,H17,H18,H20,H21,H24,H25,H26, H27,H28,MMM	1
8	PAHZZ	5360011530933	7X677	8623145	SPRING,HELICAL,COMP..... UOC:AVY,A11,A13,A14,A15,A20,A24,A25, A26,A27,B16,B17,B18,HVY,H11,H13,H14, H15,H16,H17,H18,H20,H21,H24,H25,H26, H27,H28,MMM	3
9	PAHZZ	3120011554468	7X677	8623211	BEARING,WASHER,THRU..... UOC:AVY,A11,A13,A14,A15,A20,A24,A25, A26,A27,B16,B17,B18,HVY,H11,H13,H14, H15,H16,H17,H18,H20,H21,H24,H25,H26, H27,H28,MMM	1
10	PAHZZ	3120011748153	7X677	8680914	BUSHING,SLEEVE..... UOC:AVY,A11,A13,A14,A15,A20,A24,A25,	1

SECTION II			TM9-2320-280-24P			
(1)	(2)	(3)	(4)	(5)	(6)	(7)
ITEM NO	SMR CODE	NSN	CAGEC	PART NUMBER	DESCRIPTION AND USABLE ON CODES(UC)	QTY
11	KFHZZ		11862	8626812	A26,A27,B16,B17,B18,HVY,H11,H13,H14,H15,H16,H17,H18,H20,H21,H24,H25,H26,H27,H28,MMM SUPPORT WITH RACE PART OF KIT P/N 8680914..... UC:AVY,A11,A13,A14,A15,A20,A24,A25,A26,A27,B16,B17,B18,HVY,H11,H13,H14,H15,H16,H17,H18,H20,H21,H24,H25,H26,H27,H28,MMM	1
12	PAHZZ	5330011654333	7X677	8626356	RETAINER,PACKING 2.065 O.D. PART OF KIT P/N 8629955..... UC:AVY,A11,A13,A14,A15,A20,A24,A25,A26,A27,B16,B17,B18,HVY,H11,H13,H14,H15,H16,H17,H18,H20,H21,H24,H25,H26,H27,H28,MMM	4
13	PAHZZ	5330011554383	7X677	8627627	PACKING,PREFORMED INNER PART OF KIT P/N 8629955..... UC:AVY,A11,A13,A14,A15,A20,A24,A25,A26,A27,B16,B17,B18,HVY,H11,H13,H14,H15,H16,H17,H18,H20,H21,H24,H25,H26,H27,H28,MMM	1
14	KFHZZ		11862	8623143	PACKING,PREFORMED INNER PART OF KIT P/N 8629955..... UC:AVY,A11,A13,A14,A15,A20,A24,A25,A26,A27,B16,B17,B18,HVY,H11,H13,H14,H15,H16,H17,H18,H20,H21,H24,H25,H26,H27,H28,MMM	1
15	KFHZZ		7X677	8627379	SEAL ASSEMBLY PART OF KIT P/N 8680914..... UC:AVY,A11,A13,A14,A15,A20,A24,A25,A26,A27,B16,B17,B18,HVY,H11,H13,H14,H15,H16,H17,H18,H20,H21,H24,H25,H26,H27,H28,MMM	1
16	KFHZZ		11862	8627385	CLUTCH SPRING GUIDE PART OF KIT P/N 8680914..... UC:AVY,A11,A13,A14,A15,A20,A24,A25,A26,A27,B16,B17,B18,HVY,H11,H13,H14,H15,H16,H17,H18,H20,H21,H24,H25,H26,H27,H28,MMM	1

END OF FIGURE



**USE WITH A2 VEHICLES**

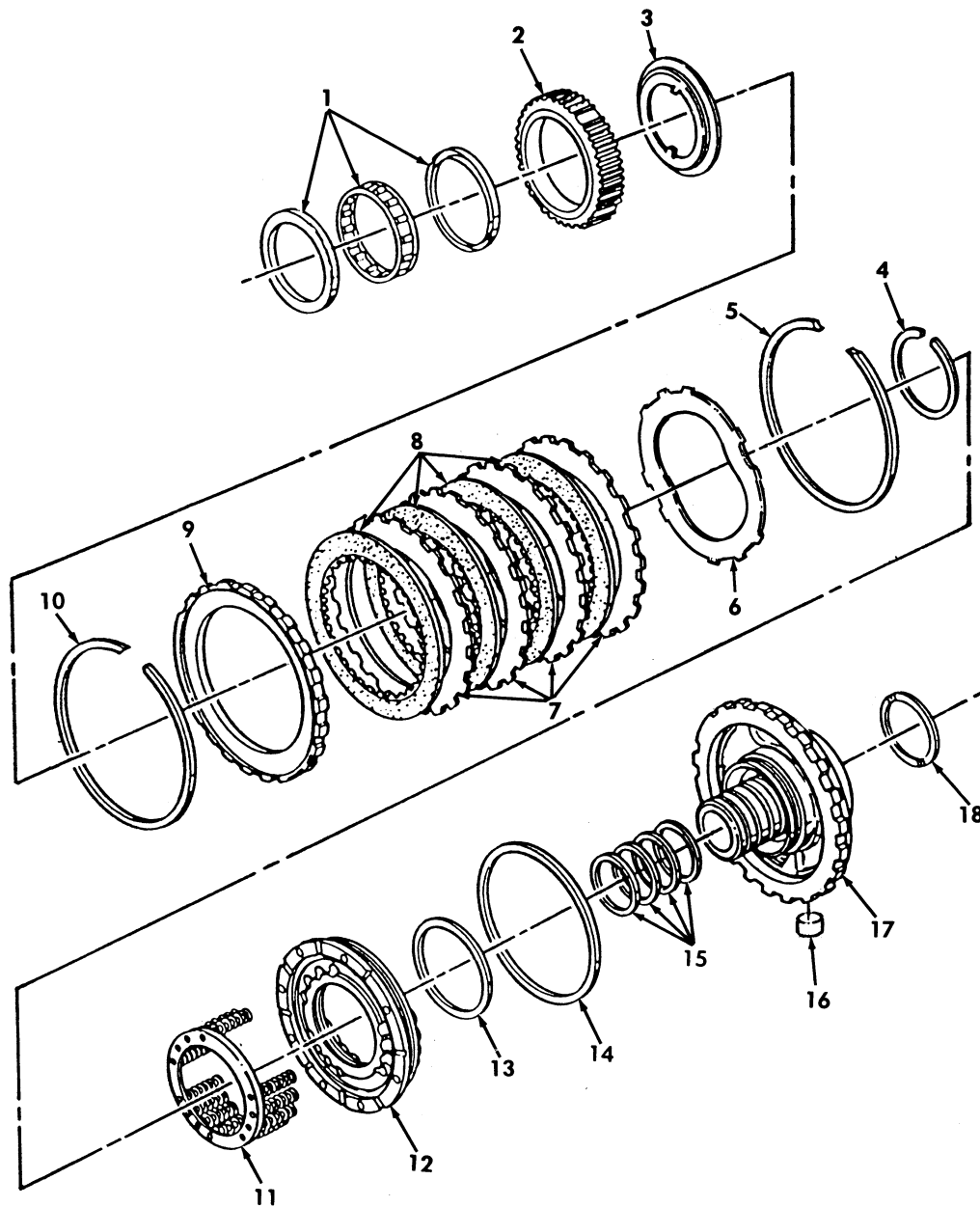

*Figure 114. Intermediate Clutch and Center Support Assembly.*

SECTION II			TM9-2320-280-24P			
(1)	(2)	(3)	(4)	(5)	(6)	(7)
ITEM NO	SMR CODE	NSN	CAGEC	PART NUMBER	DESCRIPTION AND USABLE ON CODES(UOC)	QTY
GROUP 0713 INTERMEDIATE CLUTCH						
FIG. 114 INTERMEDIATE CLUTCH AND CENTER SUPPORT ASSEMBLY						
1	PAHZZ	2520014610092	7X677	8633173	SPRAG ASSEMBLY PART OF KIT P/N 8680915.....	1
2	KFHZZ		7X677	8675520	UOC:BVY,B15,B20,B24,B25,C17,NNN RACE, OUTER PART OF KIT P/N 8680915..	1
3	PAHZZ	2520011491868	7X677	8627334	UOC:BVY,B15,B20,B24,B25,C17,NNN DISK,CLUTCH,VEHICUL PART OF KIT P/N 8680915.....	1
4	PAHZZ	5325011582182	7X677	8623153	UOC:BVY,B15,B20,B24,B25,C17,NNN RING,RETAINING.....	1
5	PAHZZ	5325011604693	7X677	8623437	UOC:BVY,B15,B20,B24,B25,C17,NNN RING,RETAINING.....	1
6	PAHZZ	2520014562736	7X677	24204497	UOC:BVY,B15,B20,B24,B25,C17,NNN DISK,CLUTCH 1996,97,98.....	1
7	PAHZZ	2520014610074	7X677	8675522	UOC:BVY,B15,B20,B24,B25,C17,NNN RING,DRIVE PLATE,TR.....	4
8	PAHZZ		7X677	8675521	UOC:BVY,B15,B20,B24,B25,C17,NNN DISK,CLUTCH 1995 PART OF KIT P/N 24204441.....	4
8	PAHZZ	2520014567883	7X677	24202966	UOC:BVY,B15,B20,B24,B25,C17,NNN DISK,CLUTCH 1996,97,98 PART OF KIT P/N 24205251 PART OF KIT P/N 24210954.....	1
9	PAHZZ	2520014610073	7X677	8675519	UOC:BVY,B15,B20,B24,B25,C17,NNN RING,DRIVE PLATE,TR.....	1
10	PAHZZ	5325011507830	7X677	8623149	UOC:BVY,B15,B20,B24,B25,C17,NNN RING,RETAINING.....	1
11	PAHZZ	2520014604961	7X677	24202976	UOC:BVY,B15,B20,B24,B25,C17,NNN SPRING AND RETAINER.....	1
12	KFHZZ		7X677	8661658	UOC:BVY,B15,B20,B24,B25,C17,NNN PISTON 1995,PART OF KIT P/N 8680914	1
12	PAHZZ	2520014748868	7X677	24202552	UOC:BVY,B15,B20,B24,B25,C17,NNN BEARING,CLUTCH 1996,97,98 PART OF KIT P/N 24208849 PART OF KIT P/N 24205348.....	1
13	PAHZZ	5330014785994	7X677	24202360	UOC:BVY,B15,B20,B24,B25,C17,NNN PACKING,PREFORMED PART OF KIT P/N 24204441 PART OF KIT P/N 24204449 PART OF KIT P/N 24205251 PART OF KIT P/N 24210954.....	1
14	PAHZZ	5330014783900	7X677	24202361	UOC:BVY,B15,B20,B24,B25,C17,NNN PACKING,PREFORMED PART OF KIT P/N 24204441 PART OF KIT P/N 24204449 PART OF KIT P/N 24205251 PART OF KIT P/N 24210954.....	1
15	KFHZZ		7X677	8675729	UOC:BVY,B15,B20,B24,B25,C17,NNN RETAINER,PACKING 1995,96,97 PART OF KIT P/N 24204441 PART OF KIT P/N 24205251 PART OF KIT P/N 24210954...	4

SECTION II			TM9-2320-280-24P			
(1)	(2)	(3)	(4)	(5)	(6)	(7)
ITEM NO	SMR CODE	NSN	CAGEC	PART NUMBER	DESCRIPTION AND USABLE ON CODES(UC)	QTY
15	KFHZZ		7X677	24205722	UC:BVY,B15,B20,B24,B25,C17,NNN RETAINER,PACKING 1998 PART OF KIT P/N 24210954.....	4
16	PAHZZ	5340014088522	7X677	8624209	UC:BVY,B15,B20,B24,B25,C17,NNN PLUG,VENT.....	1
17	KFHZZ		7X677	8683075	UC:BVY,B15,B20,B24,B25,C17,NNN SUPPORT 1995,96 PART OF KIT P/N 8680914 PART OF KIT P/N 24205348,	1
17	KFHZZ		7X677	24207180	UC:BVY,B15,B20,B24,B25,C17,NNN SUPPORT 1997,98 PART OF KIT P/N 24208849.....	1
18	PAHZZ	3120011554468	7X677	8623211	UC:BVY,B15,B20,B24,B25,C17,NNN BEARING,WASHER,THRU.....	1

END OF FIGURE

**USE WITH A2 VEHICLES**

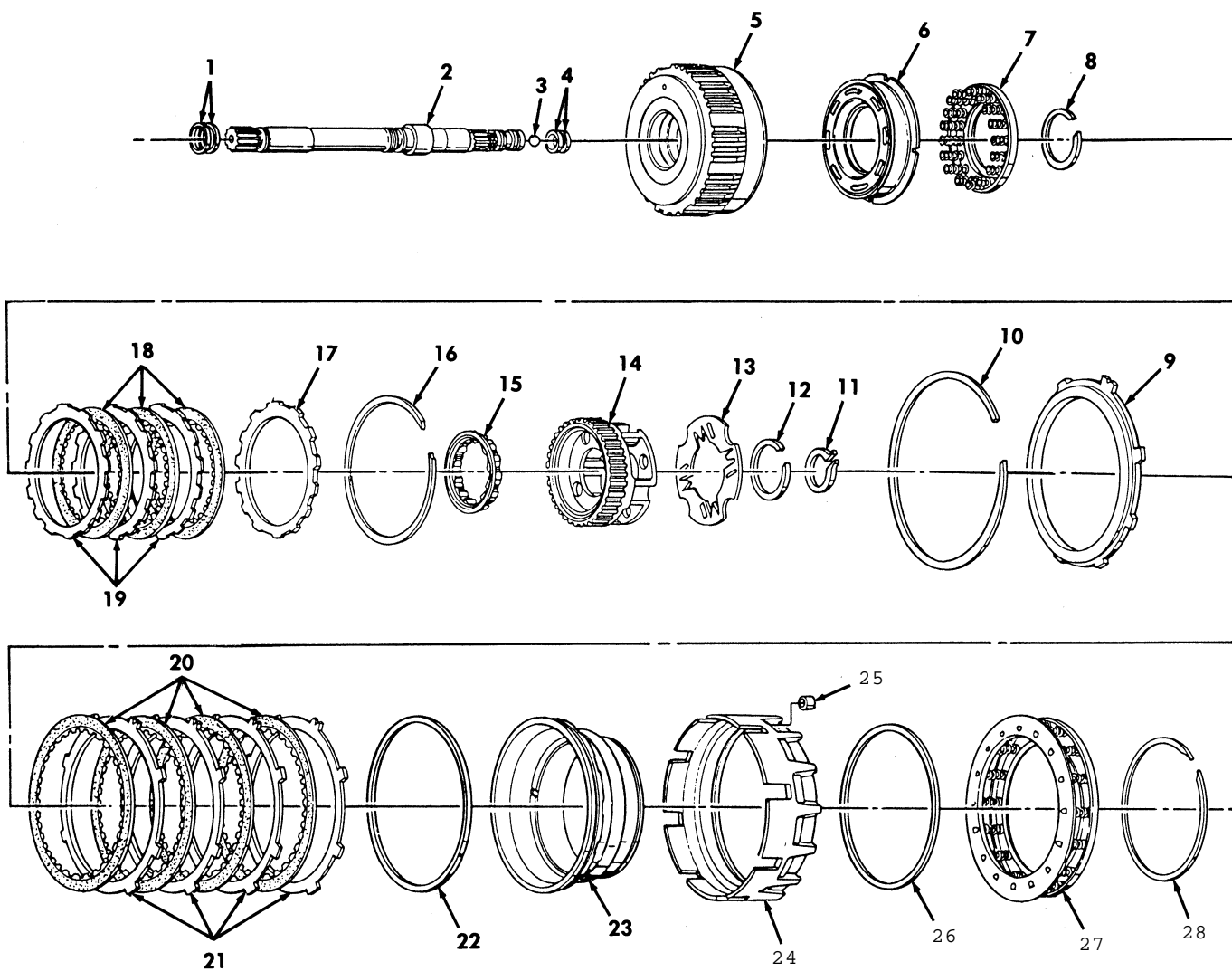

*Figure 115. Overrun, Overdrive, and Fourth Clutch Assembly.*

SECTION II			TM9-2320-280-24P			
(1)	(2)	(3)	(4)	(5)	(6)	(7)
ITEM NO	SMR CODE	NSN	CAGEC	PART NUMBER	DESCRIPTION AND USABLE ON CODES(UOC)	QTY
GROUP 0713 INTERMEDIATE CLUTCH						
FIG. 115 OVERRUN, OVERDRIVE, AND FOURTH CLUTCH ASSEMBLY						
1	PAHZA	5330014683604	24617	8661894	SEAL, PLAIN ENCASED PART OF KIT P/N 24204441 PART OF KIT P/N 25205251 PART OF KIT P/N 24210954.....	2
2	KFHZZ		7X677	24200128	UOC:BVY, B15, B20, B24, B25, C17, NNN SHAFT ASSEMBLY TURB PART OF KIT P/N 24200130 PART OF KIT P/N 8680918....	1
3	PAHZZ	3110014120490	7X677	453571	UOC:BVY, B15, B20, B24, B25, C17, NNN BALL, BEARING .28.....	2
4	KFHZZ		7X677	8661893	UOC:BVY, B15, B20, B24, B25, C17, NNN SEAL, PLAIN PART OF KIT P/N 24205251 PART OF KIT P/N 24204441 PART OF KIT P/N 24210954.....	2
5	PAHZZ	2520014108079	7X677	8680918	UOC:BVY, B15, B20, B24, B25, C17, NNN HOUSING PART, TRANSM.....	1
6	PAHZZ	2520014565014	7X677	24202092	UOC:BVY, B15, B20, B24, B25, C17, NNN CARRIER, CLUTCH ASSE.....	1
7	PAHZZ	2520014610085	7X677	8661629	UOC:BVY, B15, B20, B24, B25, C17, NNN RETAINER AND SPRING.....	1
8	PAHZZ	5325014087971	7X677	8661568	UOC:BVY, B15, B20, B24, B25, C17, NNN RING, RETAINING.....	1
9	PAHZZ	2520014091751	7X677	8661582	UOC:BVY, B15, B20, B24, B25, C17, NNN RETAINER, CLUTCH PLA.....	1
10	PAHZZ	5325014087972	7X677	8677887	UOC:BVY, B15, B20, B24, B25, C17, NNN RING, RETAINING.....	1
11	PAHZZ	5325014087969	7X677	8675523	UOC:BVY, B15, B20, B24, B25, C17, NNN RING, RETAINING.....	1
12	PAHZZ	5325014128806	7X677	8679439	UOC:BVY, B15, B20, B24, B25, C17, NNN RING, RETAINING PART OF KIT P/N 8680911.....	1
13	PAHZZ	2520014610083	7X677	8661623	UOC:BVY, B15, B20, B24, B25, C17, NNN RETAINER, CLUTCH PLA.....	1
14	PAHZZ	3010014608309	7X677	24200130	UOC:BVY, B15, B20, B24, B25, C17, NNN CARRIER, GEAR ASSEMB.....	1
15	PAHZZ	3110014115784	7X677	930678	UOC:BVY, B15, B20, B24, B25, C17, NNN RETAINER, ROLLER, BEA.....	1
16	PAHZZ	5325014087970	7X677	8661572	UOC:BVY, B15, B20, B24, B25, C17, NNN RING, RETAINING.....	1
17	PAHZZ	2520014610078	7X677	8661449	UOC:BVY, B15, B20, B24, B25, C17, NNN RETAINER, CLUTCH PLA.....	1
18	KFHZZ		7X677	8661571	UOC:BVY, B15, B20, B24, B25, C17, NNN DISK, CLUTCH PART OF KIT P/N 24205251 PART OF KIT P/N 24204441 PART OF KIT P/N 24210954.....	3
19	PAHZZ	2520014091767	7X677	8661569	UOC:BVY, B15, B20, B24, B25, C17, NNN PLATE, INTERMEDIATE.....	3
20	KFHZZ		7X677	8682802	UOC:BVY, B15, B20, B24, B25, C17, NNN DISK, CLUTCH, VEHICUL PART OF KIT P/N 24205251 PART OF KIT P/N 24204441	4

SECTION II			TM9-2320-280-24P			
(1)	(2)	(3)	(4)	(5)	(6)	(7)
ITEM	SMR			PART		
NO	CODE	NSN	CAGEC	NUMBER	DESCRIPTION AND USABLE ON CODES(UC)	QTY
					PART OF KIT P/N 24210954.....	
					UOC:BVY,B15,B20,B24,B25,C17,NNN	
21	PAHZZ	2520014113959	7X677	8661579	PLATE, INTERMEDIATE,.....	4
					UOC:BVY,B15,B20,B24,B25,C17,NNN	
22	PAHZZ	5331014144161	7X677	24202358	O-RING PART OF KIT P/N 24205251 PART	1
					OF KIT P/N 24204441 PART OF KIT P/N	
					24210954.....	
					UOC:BVY,B15,B20,B24,B25,C17,NNN	
23	PAHZZ		7X677	8661271	PISTON, CLUTCH.....	1
					UOC:BVY,B15,B20,B24,B25,C17,NNN	
24	KFHZZ		7X677	8686122	HOUSING, FRICTION CL PART OF KIT P/N	1
					24200789.....	
					UOC:BVY,B15,B20,B24,B25,C17,NNN	
25	PAHZZ	5340014088522	7X677	8624209	PLUG, VENT.....	1
					UOC:BVY,B15,B20,B24,B25,C17,NNN	
26	KFHZZ		7X677	24202357	O-RING PART OF KIT P/N 24205251 PART	1
					OF KIT P/N 24204441 PART OF KIT P/N	
					24210954.....	
					UOC:BVY,B15,B20,B24,B25,C17,NNN	
27	PAHZZ	2520014108241	7X677	8661577	CLUTCH SPRING GUIDE.....	1
					UOC:BVY,B15,B20,B24,B25,C17,NNN	
28	PAHZZ	5325014617157	7X677	8661578	RING, RETAINING.....	1
					UOC:BVY,B15,B20,B24,B25,C17,NNN	

END OF FIGURE

11 — 

12 thru 14
------------------

**USE WITH BASIC AND A1 VEHICLES**

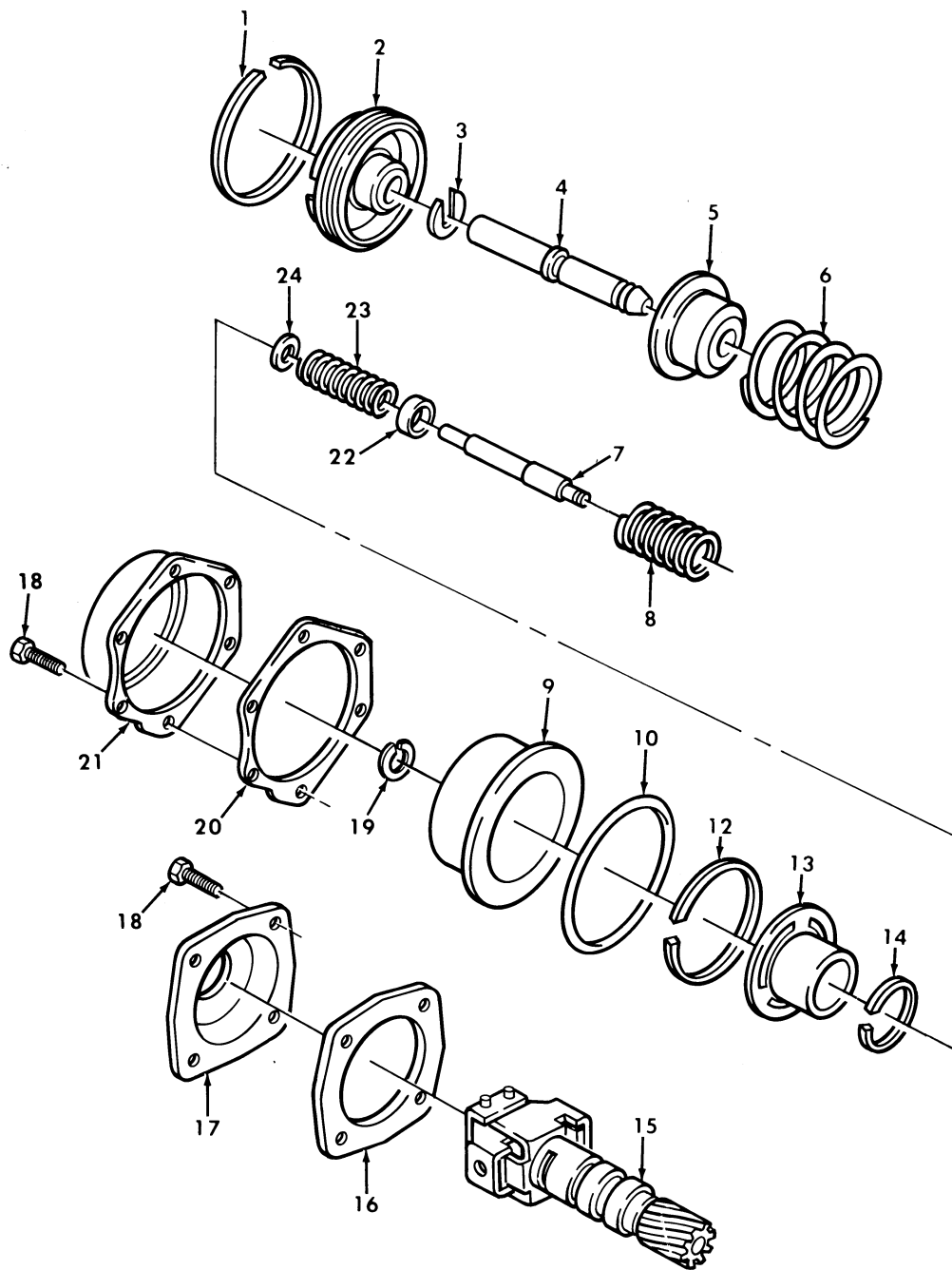

Figure 116. Front Servo, Rear Servo, and Governor Assembly.

SECTION II			TM9-2320-280-24P			
(1)	(2)	(3)	(4)	(5)	(6)	(7)
ITEM NO	SMR CODE	NSN	CAGEC	PART NUMBER	DESCRIPTION AND USABLE ON CODES(UC)	QTY
GROUP 0714 SERVO UNIT						
FIG. 116 FRONT SERVO, REAR SERVO, AND GOVERNOR ASSEMBLY						
1	PAHZZ	5330011632614	7X677	8626423	SEAL RING, METAL FRONT PART OF KIT P/N 24205251..... UOC:AVY, A11, A13, A14, A15, A20, A24, A25, A26, A27, B16, B17, B18, HVY, H11, H13, H14, H15, H16, H17, H18, H20, H21, H24, H25, H26, H27, H28, MMM	1
2	PAHZZ	3040011496759	7X677	8678537	PISTON, LINEAR ACTUA FRONT..... UOC:AVY, A11, A13, A14, A15, A20, A24, A25, A26, A27, B16, B17, B18, HVY, H11, H13, H14, H15, H16, H17, H18, H20, H21, H24, H25, H26, H27, H28, MMM	1
3	PAHZZ	5310011514137	7X677	8626884	WASHER, SLOTTED FRONT..... UOC:AVY, A11, A13, A14, A15, A20, A24, A25, A26, A27, B16, B17, B18, HVY, H11, H13, H14, H15, H16, H17, H18, H20, H21, H24, H25, H26, H27, H28, MMM	1
4	PAHZZ	5315011529031	7X677	8626879	PIN, GROOVED, HEADLES FRONT..... UOC:AVY, A11, A13, A14, A15, A20, A24, A25, A26, A27, B16, B17, B18, HVY, H11, H13, H14, H15, H16, H17, H18, H20, H21, H24, H25, H26, H27, H28, MMM	1
5	PAHZZ	5340011514964	7X677	8626881	RETAINER, HELICAL CO FRONT..... UOC:AVY, A11, A13, A14, A15, A20, A24, A25, A26, A27, B16, B17, B18, HVY, H11, H13, H14, H15, H16, H17, H18, H20, H21, H24, H25, H26, H27, H28, MMM	1
6	PAHZZ	5360011506086	7X677	8623489	SPRING, HELICAL, COMP FRONT..... UOC:AVY, A11, A13, A14, A15, A20, A24, A25, A26, A27, B16, B17, B18, HVY, H11, H13, H14, H15, H16, H17, H18, H20, H21, H24, H25, H26, H27, H28, MMM	1
7	PAHZZ	5315011529039	7X677	8624140	PIN, SHOULDER, HEADLE REAR, 2 RINGS... UOC:AVY, A11, A13, A14, A15, A20, A24, A25, A26, A27, B16, B17, B18, HVY, H11, H13, H14, H15, H16, H17, H18, H20, H21, H24, H25, H26, H27, H28, MMM	1
7	PAHZZ	5315011529040	7X677	8624141	PIN, SHOULDER, HEADLE REAR, 3 RINGS.. UOC:AVY, A11, A13, A14, A15, A20, A24, A25, A26, A27, B16, B17, B18, HVY, H11, H13, H14, H15, H16, H17, H18, H20, H21, H24, H25, H26, H27, H28, MMM	1
7	PAHZZ	5315011748644	7X677	8627192	PIN, SHOULDER, HEADLE REAR, 1 WIDE AND 1 NARROW RING..... UOC:AVY, A11, A13, A14, A15, A20, A24, A25, A26, A27, B16, B17, B18, HVY, H11, H13, H14, H15, H16, H17, H18, H20, H21, H24, H25, H26, H27, H28, MMM	1
7	PAHZZ	5315011748645	7X677	8627193	PIN, SHOULDER, HEADLE REAR, PLAIN....	1



SECTION II			TM9-2320-280-24P			
(1)	(2)	(3)	(4)	(5)	(6)	(7)
ITEM NO	SMR CODE	NSN	CAGEC	PART NUMBER	DESCRIPTION AND USABLE ON CODES(UOC)	QTY
7	PAHZZ	5315011748646	7X677	8627194	UOC:AVY,A11,A13,A14,A15,A20,A24,A25,A26,A27,B16,B17,B18,HVY,H11,H13,H14,H15,H16,H17,H18,H20,H21,H24,H25,H26,H27,H28,MMM PIN,SHOULDER,HEADLE REAR, 1 NARROW AND 1 WIDE RING.....	1
7	PAHZZ	5315011748647	7X677	8627195	UOC:AVY,A11,A13,A14,A15,A20,A24,A25,A26,A27,B16,B17,B18,HVY,H11,H13,H14,H15,H16,H17,H18,H20,H21,H24,H25,H26,H27,H28,MMM PIN,SHOULDER,HEADLE REAR, 2 WIDE RINGS.....	1
8	PAHZZ	5360011506087	7X677	8624256	UOC:AVY,A11,A13,A14,A15,A20,A24,A25,A26,A27,B16,B17,B18,HVY,H11,H13,H14,H15,H16,H17,H18,H20,H21,H24,H25,H26,H27,H28,MMM SPRING,HELICAL,COMP REAR.....	1
9	PFHZZ	3040011515663	7X677	8624138	UOC:AVY,A11,A13,A14,A15,A20,A24,A25,A26,A27,B16,B17,B18,HVY,H11,H13,H14,H15,H16,H17,H18,H20,H21,H24,H25,H26,H27,H28,MMM PISTON,LINEAR ACTUA REAR.....	1
10	PAHZZ	5330011506239	7X677	8623430	UOC:AVY,A11,A13,A14,A15,A20,A24,A25,A26,A27,B16,B17,B18,HVY,H11,H13,H14,H15,H16,H17,H18,H20,H21,H24,H25,H26,H27,H28,MMM GASKET REAR,PART OF KIT P/N 24205251 PART OF KIT P/N 24202111...	1
11	PAHZZ	2520011647157	7X677	8680929	UOC:AVY,A11,A13,A14,A15,A20,A24,A25,A26,A27,B16,B17,B18,HVY,H11,H13,H14,H15,H16,H17,H18,H20,H21,H24,H25,H26,H27,H28,MMM PISTON AND RING ASS REAR.....	1
12	PAHZZ	5330011748090	7X677	8623671	UOC:AVY,A11,A13,A14,A15,A20,A24,A25,A26,A27,B16,B17,B18,HVY,H11,H13,H14,H15,H16,H17,H18,H20,H21,H24,H25,H26,H27,H28,MMM .SEAL REAR.....	1
13	XAHZZ		11862	8727200	UOC:AVY,A11,A13,A14,A15,A20,A24,A25,A26,A27,B16,B17,B18,HVY,H11,H13,H14,H15,H16,H17,H18,H20,H21,H24,H25,H26,H27,H28,MMM .PISTON REAR.....	1
14	PAHZZ	5330014701922	7X677	8627153	UOC:AVY,A11,A13,A14,A15,A20,A24,A25,A26,A27,B16,B17,B18,HVY,H11,H13,H14,H15,H16,H17,H18,H20,H21,H24,H25,H26,H27,H28,MMM .RING,WIPER REAR.....	1
15	PAFZZ	2520011513857	7X677	8679975	UOC:AVY,A11,A13,A14,A15,A20,A24,A25,A26,A27,B16,B17,B18,HVY,H11,H13,H14,H15,H16,H17,H18,H20,H21,H24,H25,H26,H27,H28,MMM TRANSMISSION GOVERN.....	1

SECTION II			TM9-2320-280-24P			
(1)	(2)	(3)	(4)	(5)	(6)	(7)
ITEM NO	SMR CODE	NSN	CAGEC	PART NUMBER	DESCRIPTION AND USABLE ON CODES(UC)	QTY
16	PAFZZ	5330000011984	7X677	8623263	UOC:AVY,A11,A13,A14,A15,A20,A24,A25,A26,A27,B16,B17,B18,HVY,H11,H13,H14,H15,H16,H17,H18,H20,H21,H24,H25,H26,H27,H28,MMM GASKET.....	1
17	PAFZZ	2520011273969	7X677	8623262	UOC:AVY,A11,A13,A14,A15,A20,A24,A25,A26,A27,B16,B17,B18,HVY,H11,H13,H14,H15,H16,H17,H18,H20,H21,H24,H25,H26,H27,H28,MMM COVER,GOVERNOR,TRAN.....	1
18	PAFZZ	5306002264825	80204	B1821BH031C075N	BOLT,MACHINE 5/16-18 X 3/4.....	10
19	PAHZZ	5325006821762	96906	MS16633-1031	UOC:AVY,A11,A13,A14,A15,A20,A24,A25,A26,A27,B16,B17,B18,HVY,H11,H13,H14,H15,H16,H17,H18,H20,H21,H24,H25,H26,H27,H28,MMM RING,RETAINING REAR.....	1
20	PAHZZ	5330011505928	7X677	8623174	UOC:AVY,A11,A13,A14,A15,A20,A24,A25,A26,A27,B16,B17,B18,HVY,H11,H13,H14,H15,H16,H17,H18,H20,H21,H24,H25,H26,H27,H28,MMM GASKET REAR PART OF KIT P/N 8625990	1
21	PAHZZ	5340011497811	7X677	8624136	UOC:AVY,A11,A13,A14,A15,A20,A24,A25,A26,A27,B16,B17,B18,HVY,H11,H13,H14,H15,H16,H17,H18,H20,H21,H24,H25,H26,H27,H28,MMM COVER,ACCESS REAR.....	1
22	PAHZZ	5340011546559	7X677	8623664	UOC:AVY,A11,A13,A14,A15,A20,A24,A25,A26,A27,B16,B17,B18,HVY,H11,H13,H14,H15,H16,H17,H18,H20,H21,H24,H25,H26,H27,H28,MMM SEAT,HELICAL COMPRE REAR.....	1
23	PAHZZ	5360011507829	7X677	8623666	UOC:AVY,A11,A13,A14,A15,A20,A24,A25,A26,A27,B16,B17,B18,HVY,H11,H13,H14,H15,H16,H17,H18,H20,H21,H24,H25,H26,H27,H28,MMM SPRING,HELICAL,COMP REAR.....	1
24	PAHZZ	5310011505919	7X677	8623744	UOC:AVY,A11,A13,A14,A15,A20,A24,A25,A26,A27,B16,B17,B18,HVY,H11,H13,H14,H15,H16,H17,H18,H20,H21,H24,H25,H26,H27,H28,MMM WASHER,FLAT REAR.....	1

END OF FIGURE

**USE WITH A2 VEHICLES**

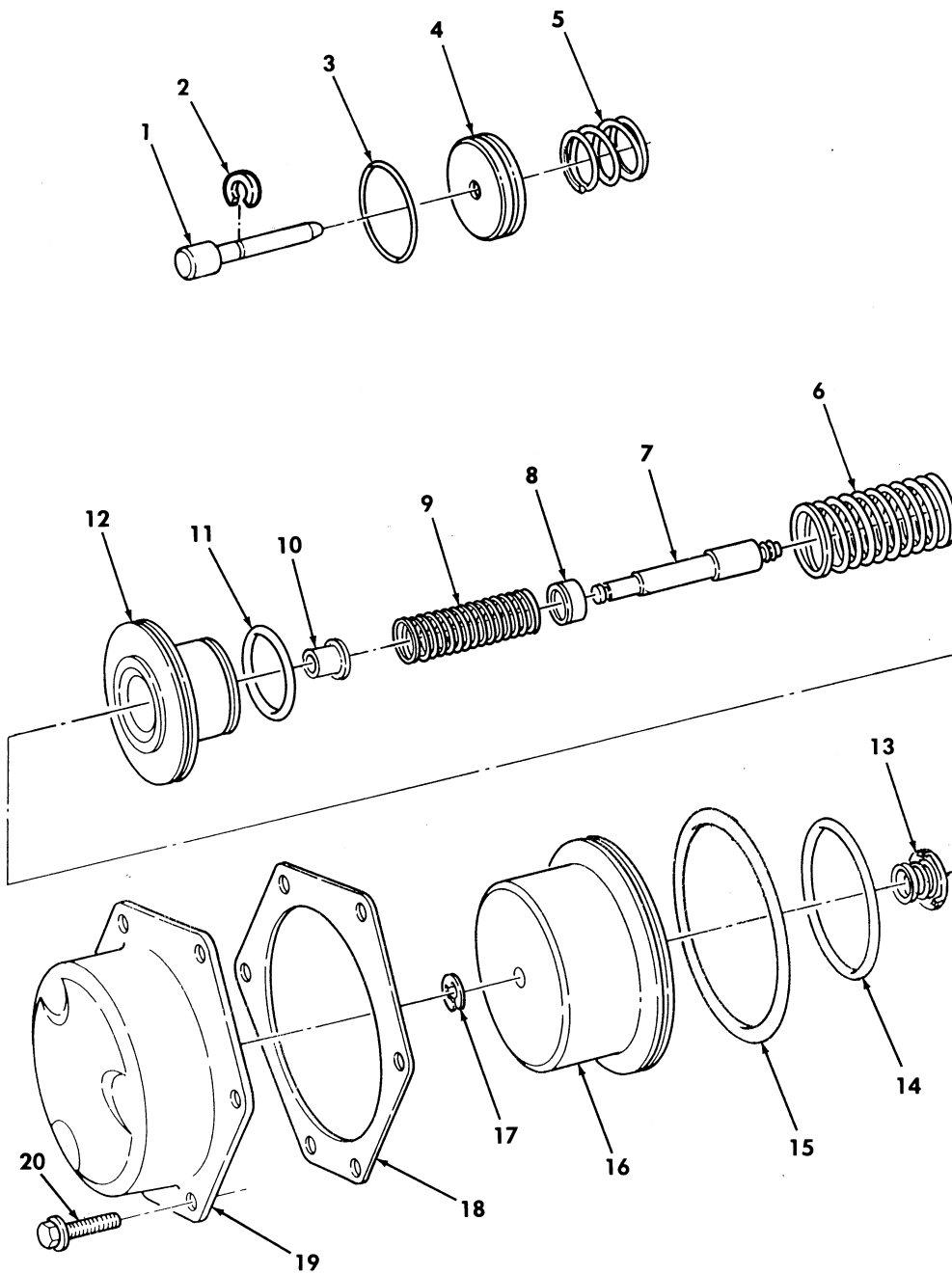

Figure 117. Front Servo, Rear Servo, and Governor Assembly.

SECTION II			TM9-2320-280-24P			
(1)	(2)	(3)	(4)	(5)	(6)	(7)
ITEM	SMR			PART		
NO	CODE	NSN	CAGEC	NUMBER	DESCRIPTION AND USABLE ON CODES(UOC)	QTY
GROUP 0714 SERVO UNIT						
FIG. 117 FRONT SERVO, REAR SERVO, AND GOVERNOR ASSEMBLY						
1	KFHZZ		7X677	8685473	PIN PART OF KIT P/N 24200418.....	1
					UOC: BVY, B15, B20, B24, B25, C17, NNN	
2	KFHZZ		7X677	8685474	WASHER, SLOTTED PART OF KIT P/N	1
					24200418.....	
					UOC: BVY, B15, B20, B24, B25, C17, NNN	
3	PAHZZ	5330011632614	7X677	8626423	SEAL RING, METAL PART OF KIT P/N	1
					24204441 PART OF KIT P/N 24200418	
					PART OF KIT P/N 24205251 PART OF KIT	
					P/N 24210954.....	
					UOC: BVY, B15, B20, B24, B25, C17, NNN	
4	KFHZZ		7X677	8685472	PISTON PART OF KIT P/N 24200418.....	1
					UOC: BVY, B15, B20, B24, B25, C17, NNN	
5	PAHZZ	5360011506086	7X677	8623489	SPRING, HELICAL, COMP.....	1
					UOC: BVY, B15, B20, B24, B25, C17, NNN	
6	PAHZZ	5360014766291	7X677	8624391	SPRING, HELICAL, COMP.....	1
					UOC: BVY, B15, B20, B24, B25, C17, NNN	
7	PAHZZ	5315014562737	7X677	24202577	PIN, SHOULDER, HEADLE 3.300-3.306,	1
					#1, 1996, 97, 98.....	
					UOC: BVY, B15, B20, B24, B25, C17, NNN	
7	PAHZZ	5315014562739	7X677	24202578	PIN, SHOULDER, HEADLE 3.356-3.362,	1
					#3, 1996, 97, 98.....	
					UOC: BVY, B15, B20, B24, B25, C17, NNN	
7	PAHZZ	5315014566254	7X677	24202579	PIN, SHOULDER, HEADLE 3.412-3.418,	1
					#5, 1996, 97, 98.....	
					UOC: BVY, B15, B20, B24, B25, C17, NNN	
7	PAHZZ	5315014562738	7X677	24202580	PIN, SHOULDER, HEADLE 3.328-3.334,	1
					#2, 1996, 97, 98.....	
					UOC: BVY, B15, B20, B24, B25, C17, NNN	
7	PAHZZ	5315014562740	7X677	24202581	PIN, SHOULDER, HEADLE 3.384-3.390,	1
					#4, 1996, 97, 98.....	
					UOC: BVY, B15, B20, B24, B25, C17, NNN	
7	PAHZZ	5315014567882	7X677	24202582	PIN, SHOULDER, HEADLE 3.440-3.446,	1
					#6, 1996, 97, 98.....	
					UOC: BVY, B15, B20, B24, B25, C17, NNN	
7	PAHZZ	5315014562743	7X677	24202583	PIN, SHOULDER, HEADLE 3.468-3.474,	1
					#7, 1996, 97, 98.....	
					UOC: BVY, B15, B20, B24, B25, C17, NNN	
7	PAHZZ	5315011529038	7X677	8624139	PIN, SHOULDER, HEADLE 3.300-3.306,	1
					#1, 1995.....	
					UOC: BVY, B15, B20, B24, B25, C17, NNN	
7	PAHZZ	5315011529039	7X677	8624140	PIN, SHOULDER, HEADLE 3.356-3.362,	1
					#3, 1995.....	
					UOC: BVY, B15, B20, B24, B25, C17, NNN	
7	PAHZZ	5315011529040	7X677	8624141	PIN, SHOULDER, HEADLE 3.412-3.418,	1
					#5, 1995.....	
					UOC: BVY, B15, B20, B24, B25, C17, NNN	
7	PAHZZ	5315011748644	7X677	8627192	PIN, SHOULDER, HEADLE 3.328-3.334,	1
					#2, 1995.....	
					UOC: BVY, B15, B20, B24, B25, C17, NNN	
7	PAHZZ	5315011748645	7X677	8627193	PIN, SHOULDER, HEADLE 3.384-3.390,	1

SECTION II			TM9-2320-280-24P			
(1)	(2)	(3)	(4)	(5)	(6)	(7)
ITEM NO	SMR CODE	NSN	CAGEC	PART NUMBER	DESCRIPTION AND USABLE ON CODES(UC)	QTY
7	PAHZZ	5315011748646	7X677	8627194	#4, 1995..... UC:BVY,B15,B20,B24,B25,C17,NNN PIN,SHOULDER,HEADLE 3.440-3.446,	1
7	PAHZZ	5315011748647	7X677	8627195	#6, 1995..... UC:BVY,B15,B20,B24,B25,C17,NNN PIN,SHOULDER,HEADLE 3.468-3.474,	1
8	PAHZZ	5340011546559	7X677	8623664	#7, 1995..... UC:BVY,B15,B20,B24,B25,C17,NNN SEAT,HELICAL COMPRE.....	1
9	PAHZZ	5360011507829	7X677	8623666	UC:BVY,B15,B20,B24,B25,C17,NNN SPRING,HELICAL,COMP.....	1
10	PAHZZ	5310011505919	7X677	8623744	UC:BVY,B15,B20,B24,B25,C17,NNN WASHER,FLAT 1995.....	1
10	PAHZZ	5365014562742	7X677	24202986	UC:BVY,B15,B20,B24,B25,C17,NNN SPACER.SLEEVE 1996,97,98.....	1
11	KFHZZ		7X677	8678294	UC:BVY,B15,B20,B24,B25,C17,NNN RING,OIL SEAL PART OF KIT P/N 8680929 PART OF KIT P/N 24205250....	1
12	KFHZZ		7X677	8678292	UC:BVY,B15,B20,B24,B25,C17,NNN PISTON,LINEAR 1995 PART OF KIT P/N 8680929.....	1
12	KFHZZ		7X677	24202928	UC:BVY,B15,B20,B24,B25,C17,NNN PISTON,LINEAR 1996,97,98 PART OF KIT P/N 24205250.....	1
13	PAHZZ	5360014562745	7X677	24202987	UC:BVY,B15,B20,B24,B25,C17,NNN SPRING,HELICAL,COMP 1996,97,98.....	1
14	KFHZZ		7X677	8661890	UC:BVY,B15,B20,B24,B25,C17,NNN RING,OIL SEAL PART OF KIT P/N 8680929 PART OF KIT P/N 24205250....	1
15	PAHZZ	5330011506239	7X677	8623430	UC:BVY,B15,B20,B24,B25,C17,NNN GASKET PART OF KIT P/N 24202111 PART OF KIT P/N 24204441 PART OF KIT P/N 24205251 PART OF KIT P/N 24210955 PART OF KIT P/N 24210954.....	1
16	PAHZZ	3040011515663	7X677	8624138	UC:BVY,B15,B20,B24,B25,C17,NNN PISTON,LINEAR ACTUA 1995.....	1
16	PAHZZ	3040014567881	7X677	24202985	UC:BVY,B15,B20,B24,B25,C17,NNN PISTON,LINEAR ACTUA 1996,97,98.....	1
17	PAHZZ	5340014792517	7X677	9413523	UC:BVY,B15,B20,B24,B25,C17,NNN CLIP,RETAINING 1995.....	1
17	PAHZZ		7X677	11514347	UC:BVY,B15,B20,B24,B25,C17,NNN CLIP,RETAINING 1996,97,98.....	1
18	PAHZZ	5330014784797	7X677	8675728	UC:BVY,B15,B20,B24,B25,C17,NNN GASKET PART OK KIT P/N 24202111 PART OF KIT P/N 24204441 PART OF KIT P/N 24205251 PART OF KIT P/N 24210955 PART OF KIT P/N 24210954.....	1
19	PAHZZ	5340014792514	7X677	8682215	UC:BVY,B15,B20,B24,B25,C17,NNN COVER,ACCESS 1995.....	1
19	PAHZZ	5340014562741	7X677	24202282	UC:BVY,B15,B20,B24,B25,C17,NNN COVER,ACCESS 1996,97,98.....	1
20	PAHZZ		7X677	8676000	UC:BVY,B15,B20,B24,B25,C17,NNN BOLT,MACHINE.....	6

END OF FIGURE

**USE WITH BASIC AND A1 VEHICLES**

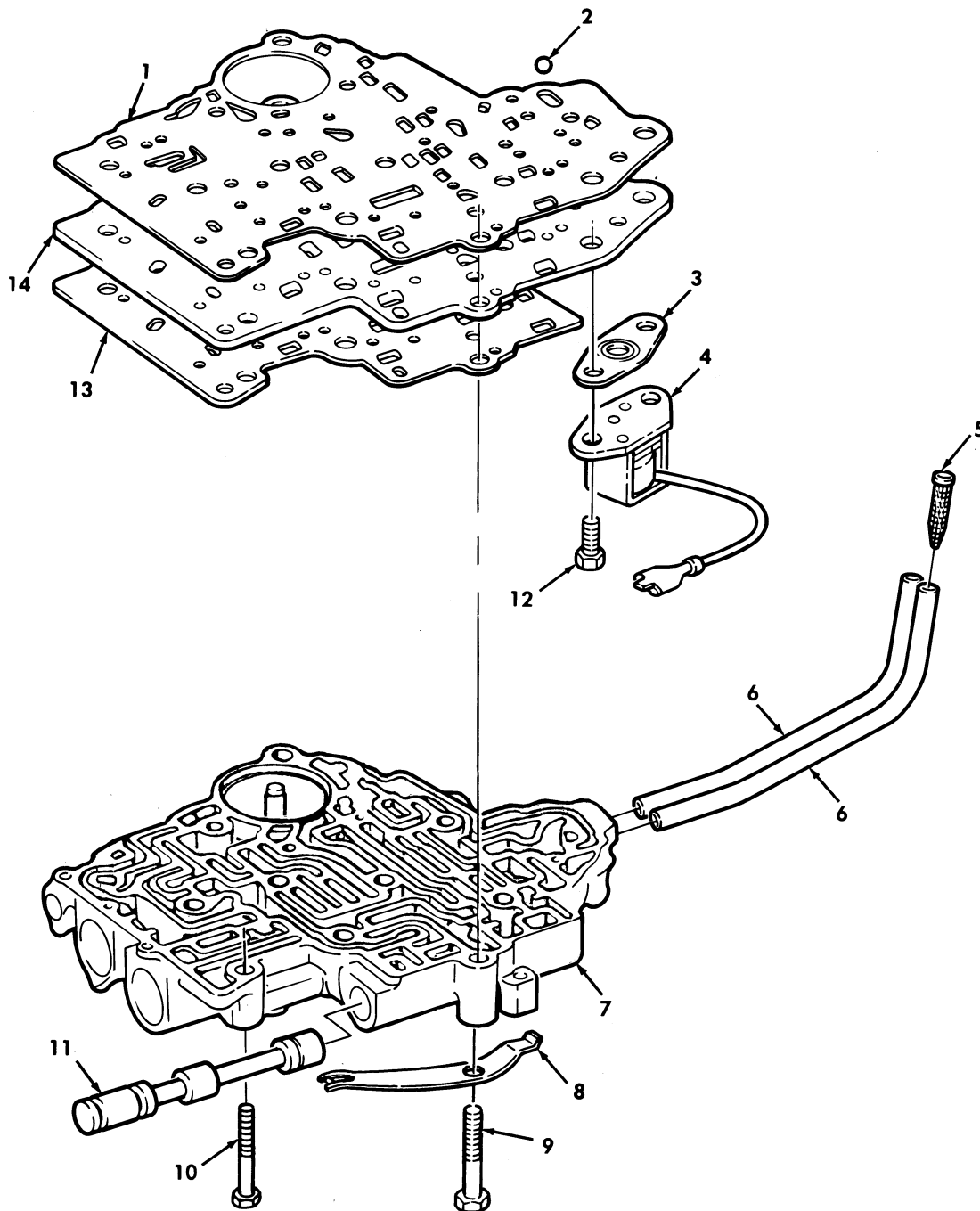

*Figure 118. Control Valve and Related Parts.*

SECTION II			TM9-2320-280-24P			
(1)	(2)	(3)	(4)	(5)	(6)	(7)
ITEM	SMR			PART		
NO	CODE	NSN	CAGEC	NUMBER	DESCRIPTION AND USABLE ON CODES(UOC)	QTY
GROUP 0714 SERVO ASSEMBLY						
FIG. 118 CONTROL VALVE AND RELATED PARTS						
1	PAHZZ	5330011516106	7X677	8670393	GASKET..... UOC:AVY,A11,A13,A14,A15,A20,A24,A25, A26,A27,B16,B17,B18,HVY,H11,H13,H14, H15,H16,H17,H18,H20,H21,H24,H25,H26, H27,H28,MMM	1
2	PAHZZ	3110009002560	96906	MS19061-20007	BALL, BEARING .25 DIA..... UOC:AVY,A11,A13,A14,A15,A20,A24,A25, A26,A27,B16,B17,B18,HVY,H11,H13,H14, H15,H16,H17,H18,H20,H21,H24,H25,H26, H27,H28,MMM	6
3	PAFZZ	5330011518364	7X677	8623741	GASKET..... UOC:AVY,A11,A13,A14,A15,A20,A24,A25, A26,A27,B16,B17,B18,HVY,H11,H13,H14, H15,H16,H17,H18,H20,H21,H24,H25,H26, H27,H28,MMM	1
4	PAFZZ	5945011757318	34623	5572142	SOLENOID, ELECTRICAL..... UOC:AVY,A11,A13,A14,A15,A20,A24,A25, A26,A27,B16,B17,B18,HVY,H11,H13,H14, H15,H16,H17,H18,H20,H21,H24,H25,H26, H27,H28,MMM	1
5	PAHZZ	4730011497935	7X677	8627509	STRAINER ELEMENT, SE..... UOC:AVY,A11,A13,A14,A15,A20,A24,A25, A26,A27,B16,B17,B18,HVY,H11,H13,H14, H15,H16,H17,H18,H20,H21,H24,H25,H26, H27,H28,MMM	1
6	PAHZZ	4710011513663	7X677	8623157	TUBE, BENT, METALLIC..... UOC:AVY,A11,A13,A14,A15,A20,A24,A25, A26,A27,B16,B17,B18,HVY,H11,H13,H14, H15,H16,H17,H18,H20,H21,H24,H25,H26, H27,H28,MMM	2
7	PAHHH	2520011609570	72590	8655027	VALVE ASSEMBLY, TRAN..... UOC:AVY,A11,A13,A14,A15,A20,A24,A25, A26,A27,B16,B17,B18,HVY,H11,H13,H14, H15,H16,H17,H18,H20,H21,H24,H25,H26, H27,H28,MMM	1
8	PAHZZ	2520011659563	7X677	8625773	ROLLER AND SPRING A..... UOC:AVY,A11,A13,A14,A15,A20,A24,A25, A26,A27,B16,B17,B18,HVY,H11,H13,H14, H15,H16,H17,H18,H20,H21,H24,H25,H26, H27,H28,MMM	1
9	PAHZZ	5306011648486	7X677	108597	BOLT, MACHINE 5/16-18 X 1.875..... UOC:AVY,A11,A13,A14,A15,A20,A24,A25, A26,A27,B16,B17,B18,HVY,H11,H13,H14, H15,H16,H17,H18,H20,H21,H24,H25,H26, H27,H28,MMM	8
10	PAHZZ	5306011508713	24617	179802	BOLT, MACHINE 1/4-20 X 1.62..... UOC:AVY,A11,A13,A14,A15,A20,A24,A25, A26,A27,B16,B17,B18,HVY,H11,H13,H14,	3

SECTION II			TM9-2320-280-24P			
(1)	(2)	(3)	(4)	(5)	(6)	(7)
ITEM NO	SMR CODE	NSN	CAGEC	PART NUMBER	DESCRIPTION AND USABLE ON CODES(UOC)	QTY
11	PAHZZ	4820011504964	7X677	8623592	H15,H16,H17,H18,H20,H21,H24,H25,H26, H27,H28,MMM VALVE,LINEAR,DIRECT.....	1
12	PAFZZ	5305000680501	96906	MS90725-5	UOC:AVY,A11,A13,A14,A15,A20,A24,A25, A26,A27,B16,B17,B18,HVY,H11,H13,H14, H15,H16,H17,H18,H20,H21,H24,H25,H26, H27,H28,MMM SCREW,CAP,HEXAGON H 1/4-20 X 5/8...	2
13	PAHZZ	5330011525942	7X677	8623561	UOC:AVY,A11,A13,A14,A15,A20,A24,A25, A26,A27,B16,B17,B18,HVY,H11,H13,H14, H15,H16,H17,H18,H20,H21,H24,H25,H26, H27,H28,MMM GASKET.....	1
14	PAHZZ	2520011541185	7X677	8629796	UOC:AVY,A11,A13,A14,A15,A20,A24,A25, A26,A27,B16,B17,B18,HVY,H11,H13,H14, H15,H16,H17,H18,H20,H21,H24,H25,H26, H27,H28,MMM PLATE,SPACER,VALVE.....	1

END OF FIGURE



**USE WITH A2 VEHICLES**

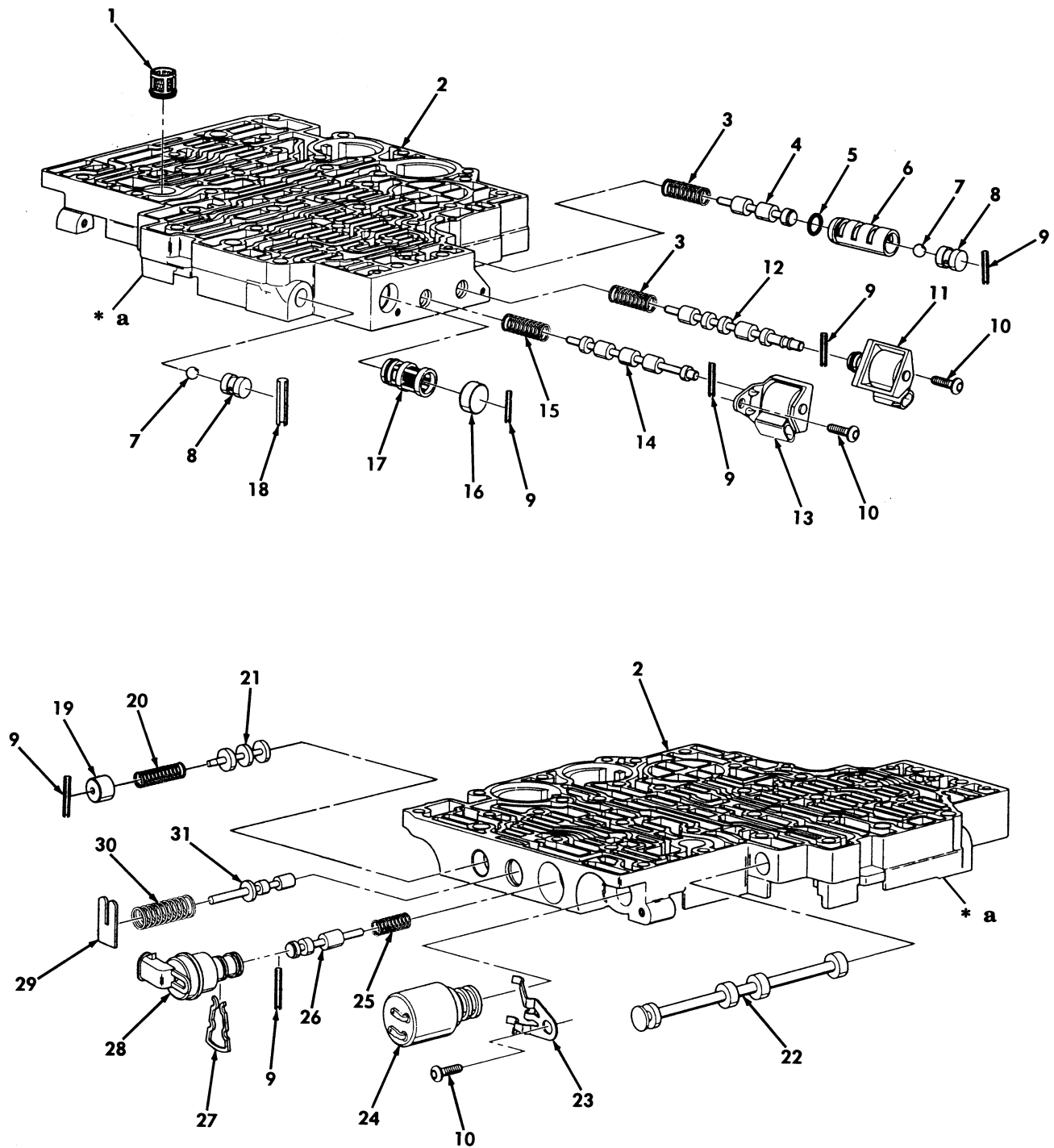

\* a SEE FIGURE 120 ITEM 12 FOR ASSEMBLY

Figure 119. Control Valve and Related Parts.

SECTION II			TM9-2320-280-24P			
(1)	(2)	(3)	(4)	(5)	(6)	(7)
ITEM	SMR			PART		
NO	CODE	NSN	CAGEC	NUMBER	DESCRIPTION AND USABLE ON CODES(UOC)	QTY
GROUP 0714 SERVO ASSEMBLY						
FIG. 119 CONTROL VALVE AND RELATED PARTS						
1	KFHZZ		7X677	8684218	FILTER ELEMENT, FLUI PART OF KIT P/N 24202111 PART OF KIT P/N 24204441 PART OF KIT P/N 24205251 PART OF KIT P/N 24210954 PART OF KIT P/N 24210955.....	1
					UOC:BVY,B15,B20,B24,B25,C17,NNN	
2	XAHZZ		7X677	24201386	BODY,CONTROL VALVE 1995.....	1
					UOC:BVY,B15,B20,B24,B25,C17,NNN	
2	XAHZZ		7X677	24202957	BODY,CONTROL VALVE 1996.....	1
					UOC:BVY,B15,B20,B24,B25,C17,NNN	
2	XAHZZ		7X677	24204266	BODY,CONTROL VALVE 1997,98.....	1
					UOC:BVY,B15,B20,B24,B25,C17,NNN	
3	PAHZZ	5360014609069	7X677	8661891	SPRING,HELICAL,COMP.....	2
					UOC:BVY,B15,B20,B24,B25,C17,NNN	
4	XAHZZ		7X677	8661801	VALVE,3-4 SHIFT.....	1
					UOC:BVY,B15,B20,B24,B25,C17,NNN	
5	PAHZZ	5330014567886	7X677	24201388	PACKING,PREFORMED.....	1
					UOC:BVY,B15,B20,B24,B25,C17,NNN	
6	XAHZZ		11862	24201390	BUSHING.....	1
					UOC:BVY,B15,B20,B24,B25,C17,NNN	
7	XAHZZ		7X677	147500	BALL .375 DIA.....	2
					UOC:BVY,B15,B20,B24,B25,C17,NNN	
8	XAHZZ		7X677	24201389	PLUG.....	2
					UOC:BVY,B15,B20,B24,B25,C17,NNN	
9	XAHZZ		7X677	8675535	PIN.....	6
					UOC:BVY,B15,B20,B24,B25,C17,NNN	
10	PAHZZ	5306014748959	7X677	11513697	BOLT,INTERNAL WRENC.....	3
					UOC:BVY,B15,B20,B24,B25,C17,NNN	
11	PAHZZ	2920013977094	7X677	10478133	COIL,ELECTRICAL 2-3 SHIFT,1995,96..	1
					UOC:BVY,B15,B20,B24,B25,C17,NNN	
11	PAHZZ		7X677	10478143	COIL,ELECTRICAL 2-3 SHIFT,1997,98..	1
					UOC:BVY,B15,B20,B24,B25,C17,NNN	
12	XAHZZ		7X677	8661804	VALVE,SHIFT.....	1
					UOC:BVY,B15,B20,B24,B25,C17,NNN	
13	PAHZZ	5950013990258	7X677	8678638	COIL,ELECTRICAL 1-2 SHIFT,1995,96...	1
					UOC:BVY,B15,B20,B24,B25,C17,NNN	
13	PAHZZ	2520014116540	7X677	10478142	VALVE,SHFT SOL 1-2 SHIFT,1997,98...	1
					UOC:BVY,B15,B20,B24,B25,C17,NNN	
14	XAHZZ		7X677	8661805	VALVE.....	1
					UOC:BVY,B15,B20,B24,B25,C17,NNN	
15	XAHZZ		7X677	8661873	SPRING.....	1
					UOC:BVY,B15,B20,B24,B25,C17,NNN	
16	XAHZZ		7X677	8661821	PLUG.....	1
					UOC:BVY,B15,B20,B24,B25,C17,NNN	
17	PAHZZ	4330014112786	7X677	8661709	FILTER ELEMENT,FLUI.....	1
					UOC:BVY,B15,B20,B24,B25,C17,NNN	
18	XAHZZ		7X677	8661867	SLEEVE.....	1
					UOC:BVY,B15,B20,B24,B25,C17,NNN	

SECTION II			TM9-2320-280-24P			
(1)	(2)	(3)	(4)	(5)	(6)	(7)
ITEM NO	SMR CODE	NSN	CAGEC	PART NUMBER	DESCRIPTION AND USABLE ON CODES (UOC)	QTY
19	XAHZZ		7X677	8661822	PLUG..... UOC:BVY,B15,B20,B24,B25,C17,NNN	1
20	XAHZZ		7X677	8676074	SPRING..... UOC:BVY,B15,B20,B24,B25,C17,NNN	1
21	XAHZZ		11862	8661807	VALVE 1995..... UOC:BVY,B15,B20,B24,B25,C17,NNN	1
21	XAHZZ		11862	24202959	VALVE 1996,97,98..... UOC:BVY,B15,B20,B24,B25,C17,NNN	1
22	PAHZZ	4820014091218	7X677	8678337	SLIDE,DIRECTIONAL C..... UOC:BVY,B15,B20,B24,B25,C17,NNN	1
23	PAHZZ	5340014608362	7X677	8684217	CLIP,SPRING TENSION..... UOC:BVY,B15,B20,B24,B25,C17,NNN	1
24	PAHZZ	5945014787862	7X677	24209276	SOLENOID..... UOC:BVY,B15,B20,B24,B25,C17,NNN	1
25	XAHZZ		7X677	8661871	SPRING..... UOC:BVY,B15,B20,B24,B25,C17,NNN	1
26	XAHZZ		7X677	8681899	VALVE..... UOC:BVY,B15,B20,B24,B25,C17,NNN	1
27	PAHZZ	5340014608364	7X677	8678523	CLIP,SPRING TENSION..... UOC:BVY,B15,B20,B24,B25,C17,NNN	1
28	PAHZZ	5950013990257	7X677	8683188	COIL,ELECTRICAL..... UOC:BVY,B15,B20,B24,B25,C17,NNN	1
29	PAHZZ	5340014608363	7X677	8684215	CLIP,SPRING TENSION..... UOC:BVY,B15,B20,B24,B25,C17,NNN	1
30	XAHZZ		7X677	8684214	SPRING..... UOC:BVY,B15,B20,B24,B25,C17,NNN	1
31	XAHZZ		7X677	8684213	VALVE..... UOC:BVY,B15,B20,B24,B25,C17,NNN	1

END OF FIGURE

**USE WITH A2 VEHICLES**

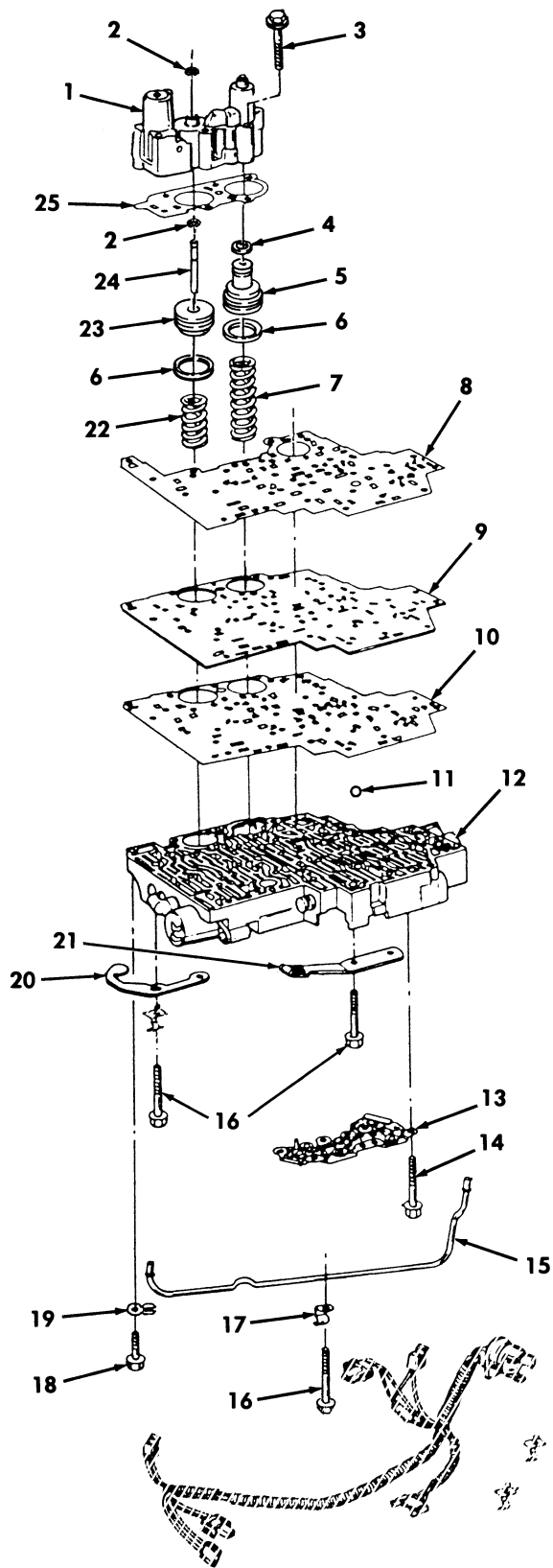
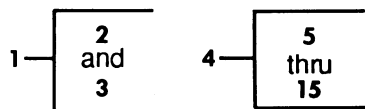

Figure 120. Control Valve, Accumulator, and Related Parts.

SECTION II			TM9-2320-280-24P			
(1)	(2)	(3)	(4)	(5)	(6)	(7)
ITEM NO	SMR CODE	NSN	CAGEC	PART NUMBER	DESCRIPTION AND USABLE ON CODES(UC)	QTY
GROUP 0714 SERVO ASSEMBLY						
FIG. 120 CONTROL VALVE,ACCUMULATOR, AND RELATED PARTS						
1	PAHHH	2520014092509	7X677	8684220	HOUSING PART,TRANSM.....	1
					UOC:BVY,B15,B20,B24,B25,C17,NNN	
2	PFHZZ	5325014087973	7X677	9413349	RING,RETAINING PART OF KIT P/N 24206749.....	2
					UOC:BVY,B15,B20,B24,B25,C17,NNN	
3	PAHZZ	5306014699903	7X677	8675533	BOLT,MACHINE.....	6
					UOC:BVY,B15,B20,B24,B25,C17,NNN	
4	PAHZA	5330014706543	7X677	8661639	PACKING,PREFORMED PART OF KIT P/N 24206749.....	1
					UOC:BVY,B15,B20,B24,B25,C17,NNN	
5	PAHZZ	2520014442711	61928	8683088	PISTON,CLUTCH SHAFT.....	1
					UOC:BVY,B15,B20,B24,B25,C17,NNN	
6	KFHZZ		7X677	8661647	PACKING,PREFORMED PART OF KIT P/N 24206749.....	2
					UOC:BVY,B15,B20,B24,B25,C17,NNN	
7	PAHZZ	5360014762692	7X677	24200436	SPRING,HELICAL,COMP.....	1
					UOC:BVY,B15,B20,B24,B25,C17,NNN	
8	KFHZZ		7X677	8684205	GASKET 1995,96 PART OF KIT P/N 24202111 PART OF KIT P/N 24204441 PART OF KIT P/N 24205251.....	1
					UOC:BVY,B15,B20,B24,B25,C17,NNN	
8	PAHZZ	5330014738584	7X677	24204268	GASKET 1997,98 PART OF KIT P/N 24210955 PART OF KIT P/N 24210954...	1
					UOC:BVY,B15,B20,B24,B25,C17,NNN	
9	PAHZZ		7X677	24200732	PLATE,SPACER,VALVE 1995.....	1
					UOC:BVY,B15,B20,B24,B25,C17,NNN	
9	PAHZZ	2520014567888	7X677	24202963	PLATE 1996.....	1
					UOC:BVY,B15,B20,B24,B25,C17,NNN	
9	PAHZZ	2520014759665	7X677	24204270	PLATE,SPACER,VALVE 1997,98.....	1
					UOC:BVY,B15,B20,B24,B25,C17,NNN	
10	PAHZZ	5330014562744	7X677	24201115	GASKET 1995,96 PART OF KIT P/N 24202111,PART OF KIT P/N 24204441...	1
					UOC:BVY,B15,B20,B24,B25,C17,NNN	
10	PAHZZ	5330014738584	7X677	24204253	GASKET 1997,98,99.....	1
					UOC:BVY,B15,B20,B24,B25,C17,NNN	
11	PAHZZ	3110009002560	96906	MS19061-20007	BALL,BEARING .25.....	8
					UOC:BVY,B15,B20,B24,B25,C17,NNN	
12	PAHHH		7X677	24201381	VALVE ASSEMBLY 1995.....	1
					UOC:BVY,B15,B20,B24,B25,C17,NNN	
12	PAHHH	2520014598532	7X677	24202943	VALVE ASSEMBLY,TRAN 1996.....	1
					UOC:BVY,B15,B20,B24,B25,C17,NNN	
12	PAHHH		7X677	24204262	VALVE ASSEMBLY 1997,98.....	1
					UOC:BVY,B15,B20,B24,B25,C17,NNN	
13	PAHZZ	5930014567880	7X677	24200695	SWITCH,PRESSURE.....	1
					UOC:BVY,B15,B20,B24,B25,C17,NNN	
14	PAHZZ	5306014763501	7X677	8676222	BOLT,MACHINE 6 X 1MM.....	6
					UOC:BVY,B15,B20,B24,B25,C17,NNN	
15	PAHZZ	4710014779034	7X677	8678342	TUBE,BENT,METALLIC 1995,96.....	1

SECTION II			TM9-2320-280-24P			
(1)	(2)	(3)	(4)	(5)	(6)	(7)
ITEM NO	SMR CODE	NSN	CAGEC	PART NUMBER	DESCRIPTION AND USABLE ON CODES(UOC)	QTY
15	PAHZZ	4710014779032	7X677	24204275	UOC:BVY,B15,B20,B24,B25,C17,NNN TUBE,BENT,METALLIC 1997,98.....	1
16	PAHZZ	5306014763500	7X677	11515262	UOC:BVY,B15,B20,B24,B25,C17,NNN BOLT,MACHINE 6 X 1 X 55MM.....	21
17	PAHZZ		7X677	8675537	UOC:BVY,B15,B20,B24,B25,C17,NNN STRAP,RETAINING..1995,96.....	1
17	PAHZZ		7X677	24204276	UOC:BVY,B15,B20,B24,B25,C17,NNN CLIP,RETAINING 1997,1998.....	1
18	PAHZZ	5306014746117	24617	11503870	UOC:BVY,B15,B20,B24,B25,C17,NNN BOLT,MACHINE 1995,96.....	1
19	PAHZZ	5340014789995	7X677	8675538	UOC:BVY,B15,B20,B24,B25,C17,NNN CLIP,RETAINING 1995,96.....	1
20	PAHZZ	2520014566256	7X677	24201116	UOC:BVY,B15,B20,B24,B25,C17,NNN STOP,OIL DIPSTICK 1995,96.....	1
21	PAHZZ	5340014744002	7X677	8676418	UOC:BVY,B15,B20,B24,B25,C17,NNN CLIP,SPRING TENSION.....	1
22	PAHZZ	5360014698077	7X677	8675634	UOC:BVY,B15,B20,B24,B25,C17,NNN SPRING,HELICAL,COMP.....	1
23	PAHZZ	5340014088525	7X677	24206025	UOC:BVY,B15,B20,B24,B25,C17,NNN PISTON PART OF KIT P/N 24206749.....	1
24	KFHZZ		7X677	24206024	UOC:BVY,B15,B20,B24,B25,C17,NNN PIN,STRAIGHT,HEADLE PART OF KIT P/N 24206749.....	1
25	KFHZZ		7X677	8661829	UOC:BVY,B15,B20,B24,B25,C17,NNN GASKET PART OF KIT P/N 24205251,PART OF KIT P/N 24202111,PART OF KIT P/N 24204441 PART OF KIT P/N 24210955 PART OF KIT P/N 24210954.....	1

END OF FIGURE



**USE WITH BASIC AND A1 VEHICLES**

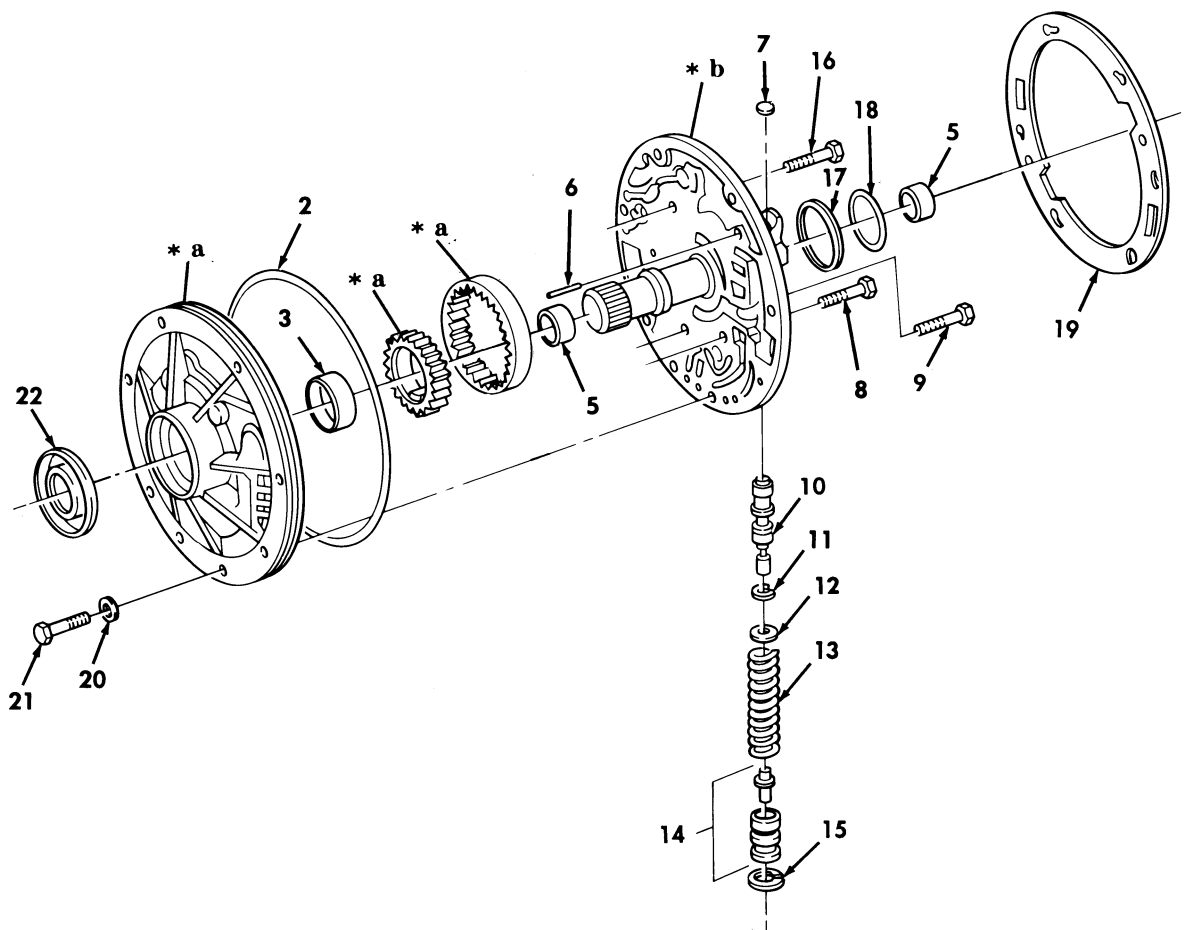

- \* a PART OF ITEM 1
- \* b PART OF ITEM 4

*Figure 121. Transmission Oil Pump.*

SECTION II			TM9-2320-280-24P			
(1)	(2)	(3)	(4)	(5)	(6)	(7)
ITEM NO	SMR CODE	NSN	CAGEC	PART NUMBER	DESCRIPTION AND USABLE ON CODES(UOC)	QTY
GROUP 0721 COOLERS,PUMPS,MOTORS						
FIG. 121 TRANSMISSION OIL PUMP						
1	PAHHH	4320011491866	72590	8679988	HOUSING,LIQUID PUMP..... UOC:AVY,A11,A13,A14,A15,A20,A24,A25, A26,A27,B16,B17,B18,HVY,H11,H13,H14, H15,H16,H17,H18,H20,H21,H24,H25,H26, H27,H28,MMM	1
2	PAHZZ	5330013240906	7X677	8654716	.SEAL,PLAIN ENCASED..... UOC:AVY,A11,A13,A14,A15,A20,A24,A25, A26,A27,B16,B17,B18,HVY,H11,H13,H14, H15,H16,H17,H18,H20,H21,H24,H25,H26, H27,H28,MMM	1
3	PAHZZ	5365010850910	7X677	8629961	.BUSHING..... UOC:AVY,A11,A13,A14,A15,A20,A24,A25, A26,A27,B16,B17,B18,HVY,H11,H13,H14, H15,H16,H17,H18,H20,H21,H24,H25,H26, H27,H28,MMM	1
4	PAHHH	5340011491867	7X677	8625955	COVER,ACCESS..... UOC:AVY,A11,A13,A14,A15,A20,A24,A25, A26,A27,B16,B17,B18,HVY,H11,H13,H14, H15,H16,H17,H18,H20,H21,H24,H25,H26, H27,H28,MMM	1
5	PAHZZ	3120011565189	7X677	8623944	.BEARING,SLEEVE..... UOC:AVY,A11,A13,A14,A15,A20,A24,A25, A26,A27,B16,B17,B18,HVY,H11,H13,H14, H15,H16,H17,H18,H20,H21,H24,H25,H26, H27,H28,MMM	2
6	PAHZZ	5315000383059	7X677	8623078	.PIN..... UOC:AVY,A11,A13,A14,A15,A20,A24,A25, A26,A27,B16,B17,B18,HVY,H11,H13,H14, H15,H16,H17,H18,H20,H21,H24,H25,H26, H27,H28,MMM	1
7	PAHZZ	5340011591788	7X677	8623292	.DISK,SOLID,PLAIN..... UOC:AVY,A11,A13,A14,A15,A20,A24,A25, A26,A27,B16,B17,B18,HVY,H11,H13,H14, H15,H16,H17,H18,H20,H21,H24,H25,H26, H27,H28,MMM	1
8	PAHZZ	5306002264832	80204	B1821BH031C175N	.BOLT,MACHINE 5/16-18 X 1.75..... UOC:AVY,A11,A13,A14,A15,A20,A24,A25, A26,A27,B16,B17,B18,HVY,H11,H13,H14, H15,H16,H17,H18,H20,H21,H24,H25,H26, H27,H28,MMM	1
9	PAHZZ	5305002264831	80204	B1821BH031C150N	.SCREW,CAP,HEXAGON H 5/16-18 X 1.50 UOC:AVY,A11,A13,A14,A15,A20,A24,A25, A26,A27,B16,B17,B18,HVY,H11,H13,H14, H15,H16,H17,H18,H20,H21,H24,H25,H26, H27,H28,MMM	2
10	PAHZZ	4820012126763	7X677	8639718	.SLIDE,DIRECTIONAL C..... UOC:AVY,A11,A13,A14,A15,A20,A24,A25, A26,A27,B16,B17,B18,HVY,H11,H13,H14, H15,H16,H17,H18,H20,H21,H24,H25,H26,	1



SECTION II		TM9-2320-280-24P			(6)	(7)
(1)	(2)	(3)	(4)	(5)		
ITEM	SMR			PART		
NO	CODE	NSN	CAGEC	NUMBER	DESCRIPTION AND USABLE ON CODES(UOC)	QTY
11	PAHZZ	5310011497793	7X677	8623368	H27, H28, MMM .WASHER, SPLIT.....	1
					UOC:AVY, A11, A13, A14, A15, A20, A24, A25, A26, A27, B16, B17, B18, HVY, H11, H13, H14, H15, H16, H17, H18, H20, H21, H24, H25, H26, H27, H28, MMM	
12	PAHZZ	5310011524229	7X677	8623039	.WASHER, KEY.....	1
					UOC:AVY, A11, A13, A14, A15, A20, A24, A25, A26, A27, B16, B17, B18, HVY, H11, H13, H14, H15, H16, H17, H18, H20, H21, H24, H25, H26, H27, H28, MMM	
13	PAHZZ	5360012097715	7X677	8623090	.SPRING, HELICAL, COMP.....	1
					UOC:AVY, A11, A13, A14, A15, A20, A24, A25, A26, A27, B16, B17, B18, HVY, H11, H13, H14, H15, H16, H17, H18, H20, H21, H24, H25, H26, H27, H28, MMM	
14	PAHZZ	5340012097830	7X677	8623915	.SEAT, HELICAL COMPRE.....	1
					UOC:AVY, A11, A13, A14, A15, A20, A24, A25, A26, A27, B16, B17, B18, HVY, H11, H13, H14, H15, H16, H17, H18, H20, H21, H24, H25, H26, H27, H28, MMM	
15	PAHZZ	5325003498518	73342	274613	.RING, RETAINING.....	1
					UOC:AVY, A11, A13, A14, A15, A20, A24, A25, A26, A27, B16, B17, B18, HVY, H11, H13, H14, H15, H16, H17, H18, H20, H21, H24, H25, H26, H27, H28, MMM	
16	PAHZZ	5305011220253	73183	179818	SCREW, CAP, HEXAGON H 5/16-18 X 1.00.	2
					UOC:AVY, A11, A13, A14, A15, A20, A24, A25, A26, A27, B16, B17, B18, HVY, H11, H13, H14, H15, H16, H17, H18, H20, H21, H24, H25, H26, H27, H28, MMM	
17	PAHZZ	3120011554462	7X677	8623300	BEARING, WASHER, THRU .060-.064.....	V
					UOC:AVY, A11, A13, A14, A15, A20, A24, A25, A26, A27, B16, B17, B18, HVY, H11, H13, H14, H15, H16, H17, H18, H20, H21, H24, H25, H26, H27, H28, MMM	
17	PAHZZ	3120011554463	7X677	8623301	BEARING, WASHER, THRU .071-.075.....	V
					UOC:AVY, A11, A13, A14, A15, A20, A24, A25, A26, A27, B16, B17, B18, HVY, H11, H13, H14, H15, H16, H17, H18, H20, H21, H24, H25, H26, H27, H28, MMM	
17	PAHZZ	3120011828417	7X677	8623302	BEARING, WASHER, THRU .082-.086.....	V
					UOC:AVY, A11, A13, A14, A15, A20, A24, A25, A26, A27, B16, B17, B18, HVY, H11, H13, H14, H15, H16, H17, H18, H20, H21, H24, H25, H26, H27, H28, MMM	
17	PAHZZ	3120011554464	7X677	8623303	BEARING, WASHER, THRU .093-.097.....	V
					UOC:AVY, A11, A13, A14, A15, A20, A24, A25, A26, A27, B16, B17, B18, HVY, H11, H13, H14, H15, H16, H17, H18, H20, H21, H24, H25, H26, H27, H28, MMM	
17	PAHZZ	3120011554465	7X677	8623304	BEARING, WASHER, THRU .104-.108.....	V

SECTION II			TM9-2320-280-24P			
(1)	(2)	(3)	(4)	(5)	(6)	(7)
ITEM NO	SMR CODE	NSN	CAGEC	PART NUMBER	DESCRIPTION AND USABLE ON CODES(UC)	QTY
					UOC:AVY,A11,A13,A14,A15,A20,A24,A25,A26,A27,B16,B17,B18,HVY,H11,H13,H14,H15,H16,H17,H18,H20,H21,H24,H25,H26,H27,H28,MMM	
17	PAHZZ	3120011554466	7X677	8623305	BEARING,WASHER,THRU .113-.119..... V	
					UOC:AVY,A11,A13,A14,A15,A20,A24,A25,A26,A27,B16,B17,B18,HVY,H11,H13,H14,H15,H16,H17,H18,H20,H21,H24,H25,H26,H27,H28,MMM	
17	PAHZZ	3120011554467	7X677	8623306	BEARING,WASHER,THRU .126-.130..... V	
					UOC:AVY,A11,A13,A14,A15,A20,A24,A25,A26,A27,B16,B17,B18,HVY,H11,H13,H14,H15,H16,H17,H18,H20,H21,H24,H25,H26,H27,H28,MMM	
18	PAHZZ	5330011654333	7X677	8626356	RETAINER,PACKING.....	2
					UOC:AVY,A11,A13,A14,A15,A20,A24,A25,A26,A27,B16,B17,B18,HVY,H11,H13,H14,H15,H16,H17,H18,H20,H21,H24,H25,H26,H27,H28,MMM	
19	PAHZZ	5330011525941	7X677	8623978	GASKET.....	1
					UOC:AVY,A11,A13,A14,A15,A20,A24,A25,A26,A27,B16,B17,B18,HVY,H11,H13,H14,H15,H16,H17,H18,H20,H21,H24,H25,H26,H27,H28,MMM	
20	PAHZZ	5310011505921	7X677	8626281	WASHER,FLAT 5/16.....	6
					UOC:AVY,A11,A13,A14,A15,A20,A24,A25,A26,A27,B16,B17,B18,HVY,H11,H13,H14,H15,H16,H17,H18,H20,H21,H24,H25,H26,H27,H28,MMM	
21	PAHZZ	5306012694319	7X677	8655280	BOLT,MACHINE 5/16 X 1.406.....	6
					UOC:AVY,A11,A13,A14,A15,A20,A24,A25,A26,A27,B16,B17,B18,HVY,H11,H13,H14,H15,H16,H17,H18,H20,H21,H24,H25,H26,H27,H28,MMM	
22	PAFZZ	5330010254212	24617	8626916	SEAL,PLAIN ENCASED PART OF KIT P/N 8629955.....	1
					UOC:AVY,A11,A13,A14,A15,A20,A24,A25,A26,A27,B16,B17,B18,HVY,H11,H13,H14,H15,H16,H17,H18,H20,H21,H24,H25,H26,H27,H28,MMM	

END OF FIGURE

USE WITH A2 VEHICLES

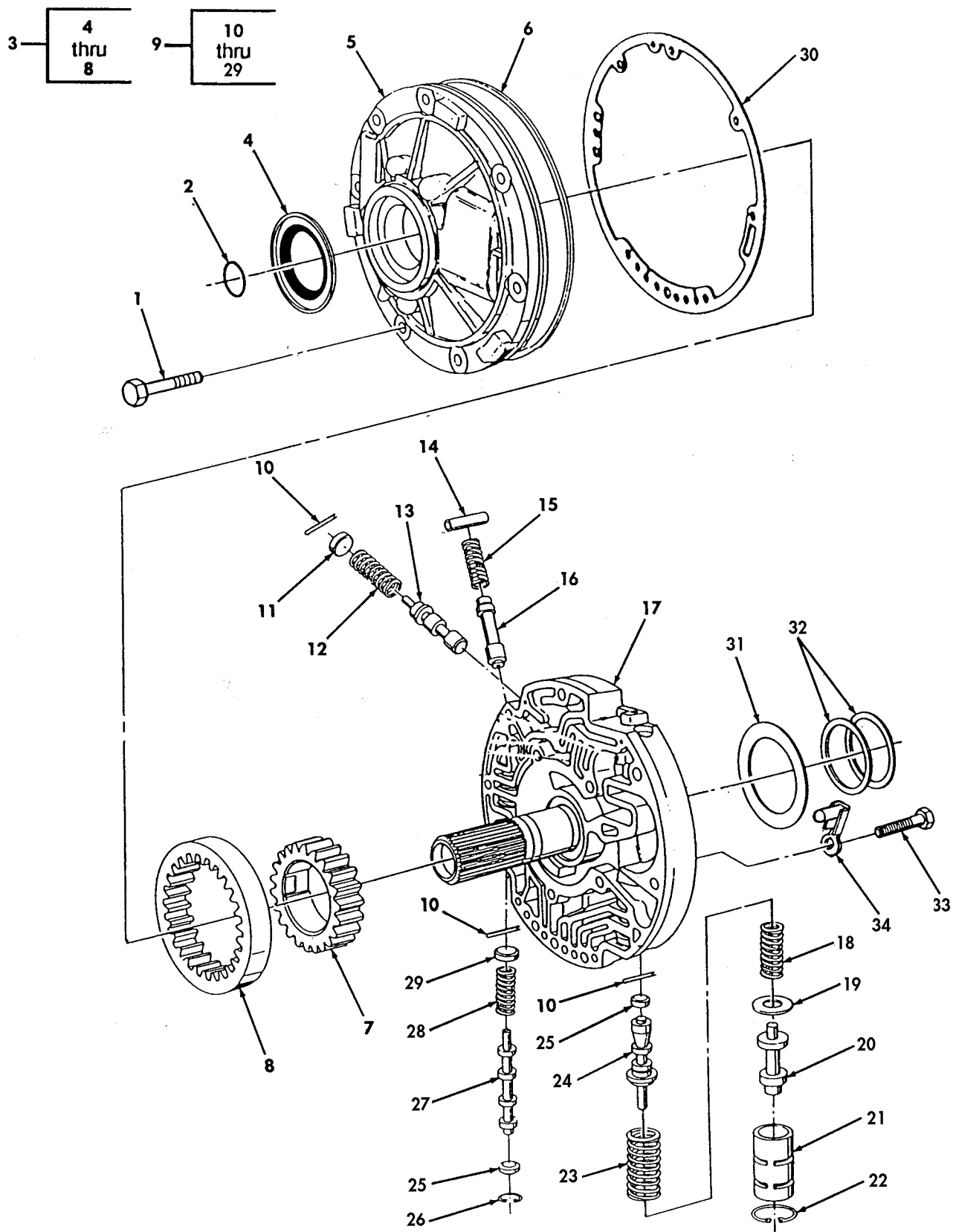

Figure 122. Transmission Oil Pump.

SECTION II			TM9-2320-280-24P			
(1)	(2)	(3)	(4)	(5)	(6)	(7)
ITEM NO	SMR CODE	NSN	CAGEC	PART NUMBER	DESCRIPTION AND USABLE ON CODES(UOC)	QTY
GROUP 0721 COOLERS,PUMPS,MOTORS						
FIG. 122 TRANSMISSION OIL PUMP						
1	PAHZZ	53060141111596	7X677	8661792	BOLT,MACHINE PART OF KIT P/N 24205251 PART OF KIT P/N 24202111 PART OF KIT P/N 24204441 PART OF KIT P/N 24210955 PART OF KIT P/N 24210954.....	7
2	PAHZZ	5330014146607	7X677	8661760	UOC:BVY,B15,B20,B24,B25,C17,NNN SEAL,PLAIN.....	1
3	PAHHH	4320013982069	7X677	24208852	UOC:BVY,B15,B20,B24,B25,C17,NNN PUMP,ROTARY 1995,96.....	1
3	PAHHH	4320013982069	7X677	24211287	UOC:BVY,B15,B20,B24,B25,C17,NNN PUMP,ROTARY 1997,98.....	1
4	PAHZZ	5330013791139	7X677	8661602	UOC:BVY,B15,B20,B24,B25,C17,NNN .SEAL,PLAIN PART OF KIT P/N 24202111, PART OF KIT P/N 24204441.....	1
5	XAHZZ		7X677	8682194	UOC:BVY,B15,B20,B24,B25,C17,NNN .BODY,OIL PUMP 1995,96.....	1
5	XAHZZ		7X677	24205778	UOC:BVY,B15,B20,B24,B25,C17,NNN .BODY,OIL PUMP 1997,98.....	1
6	PAHZZ	5330013240906	7X677	8654716	UOC:BVY,B15,B20,B24,B25,C17,NNN .SEAL,PLAIN ENCASED.....	1
7	XAHZZ		7X677	8661682	UOC:BVY,B15,B20,B24,B25,C17,NNN .GEAR 1995,96.....	1
7	XAHZZ		7X677	24205786	UOC:BVY,B15,B20,B24,B25,C17,NNN .GEAR 1997,98.....	1
8	XAHZZ		7X677	8661683	UOC:BVY,B15,B20,B24,B25,C17,NNN .GEAR.....	1
9	PAHHH		7X677	24205398	UOC:BVY,B15,B20,B24,B25,C17,NNN COVER ASSEMBLY,TRAN 1995,96.....	1
9	PAHHH	2520014658809	7X677	24204303	UOC:BVY,B15,B20,B24,B25,C17,NNN COVER ASSEMBLY,TRAN 1997,98.....	1
10	PAHZZ	5315014618374	7X677	8661838	UOC:BVY,B15,B20,B24,B25,C17,NNN .PIN,STRAIGHT,HEADLE.....	3
11	PAHZZ	5340014777052	7X677	8682858	UOC:BVY,B15,B20,B24,B25,C17,NNN .PLUG,EXPANSION.....	1
12	PAHZZ	5360014609068	7X677	8678258	UOC:BVY,B15,B20,B24,B25,C17,NNN .SPRING,HELICAL,COMP.....	1
13	PAHZZ	4820014609991	7X677	8678257	UOC:BVY,B15,B20,B24,B25,C17,NNN .VALVE,LINEAR,DIRECT.....	1
14	PAHZZ	5315014615649	7X677	8661768	UOC:BVY,B15,B20,B24,B25,C17,NNN .PIN,STRAIGHT,HEADLE.....	1
15	PFHZZ	5360014087977	7X677	8661767	UOC:BVY,B15,B20,B24,B25,C17,NNN .SPRING,HELICAL,COMP.....	1
16	PAHZZ	4810014609975	7X677	8661766	UOC:BVY,B15,B20,B24,B25,C17,NNN .SLIDE,DIRECTIONAL C.....	1
17	XAHZZ		7X677	24202681	UOC:BVY,B15,B20,B24,B25,C17,NNN .COVER,PUMP 1995,96.....	1
17	XAHZZ		7X677	24204304	UOC:BVY,B15,B20,B24,B25,C17,NNN .COVER,PUMP 1997,98.....	1

SECTION II			TM9-2320-280-24P			
(1)	(2)	(3)	(4)	(5)	(6)	(7)
ITEM NO	SMR CODE	NSN	CAGEC	PART NUMBER	DESCRIPTION AND USABLE ON CODES(UCO)	QTY
18	PAHZZ	5360014609073	7X677	8680551	. SPRING, HELICAL, COMP..... UCO: BVY, B15, B20, B24, B25, C17, NNN	1
19	PAHZZ	3120014616680	7X677	8680548	. BEARING, WASHER, THRU..... UCO: BVY, B15, B20, B24, B25, C17, NNN	1
20	PAHZZ	4820014610011	7X677	8680549	. VALVE, LINEAR, DIRECT..... UCO: BVY, B15, B20, B24, B25, C17, NNN	1
21	PAHZZ	5340014608361	7X677	8682856	. BUSHING..... UCO: BVY, B15, B20, B24, B25, C17, NNN	1
22	PAHZZ	5325014776608	7X677	8679465	. RING, RETAINING..... UCO: BVY, B15, B20, B24, B25, C17, NNN	1
23	PAHZZ	5360014609070	7X677	8661798	. SPRING, HELICAL, COMP..... UCO: BVY, B15, B20, B24, B25, C17, NNN	1
24	PAHZZ	4820014608288	7X677	8680547	. SLIDE, DIRECTIONAL C..... UCO: BVY, B15, B20, B24, B25, C17, NNN	1
25	PAHZZ	2520014615133	7X677	8682855	. PLUG, TRANSMISSION O 1995,96,97,98. UCO: BVY, B15, B20, B24, B25, C17, NNN	2
26	PAHZA	2010009375599	73342	274267	. RING REDUCTION, GEAR..... UCO: BVY, B15, B20, B24, B25, C17, NNN	1
27	PAHZZ	4820014609988	7X677	8681070	. VALVE, LINEAR, DIRECT..... UCO: BVY, B15, B20, B24, B25, C17, NNN	1
28	PAHZZ	5360014609072	7X677	8681069	. SPRING, HELICAL, COMP..... UCO: BVY, B15, B20, B24, B25, C17, NNN	1
29	PAHZZ	2520014615648	7X677	8682857	. PLUG, TRANSMISSION V..... UCO: BVY, B15, B20, B24, B25, C17, NNN	1
30	PAHZZ	5330014091665	7X677	8677782	GASKET PART OF KIT P/N 24205251, PART OF KIT P/N 24202111..... UCO: BVY, B15, B20, B24, B25, C17, NNN	1
31	PAHZZ	3120014616679	7X677	8677571	BEARING, WASHER, THRU .059..... UCO: BVY, B15, B20, B24, B25, C17, NNN	1
31	PAHZZ	3120014717844	7X677	8677572	BEARING, WASHER, THRU .075..... UCO: BVY, B15, B20, B24, B25, C17, NNN	1
31	PAHZZ	3120014115783	7X677	8677573	BEARING, WASHER, THRU .091..... UCO: BVY, B15, B20, B24, B25, C17, NNN	1
31	PAHZZ	3120014115787	7X677	8677574	BEARING, WASHER, THRU .107..... UCO: BVY, B15, B20, B24, B25, C17, NNN	1
31	PAHZZ	3120014616677	7X677	8677575	BEARING, WASHER, THRU .123..... UCO: BVY, B15, B20, B24, B25, C17, NNN	1
32	PAHZA	5331014627294	7X677	8661789	O-RING 1995,96,97 PART OF KIT P/N 24204441 PART OF KIT P/N 24205251 PART OF KIT P/N 24210954..... UCO: BVY, B15, B20, B24, B25, C17, NNN	2
32	PAHZZ	5331014776762	7X677	24205833	O-RING 1998 PART OF KIT P/N 24210954..... UCO: BVY, B15, B20, B24, B25, C17, NNN	2
33	PAHZZ	5306011501190	72582	11500921	BOLT, MACHINE..... UCO: BVY, B15, B20, B24, B25, C17, NNN	5
34	PAHZZ	4320014566258	7X677	24200357	SHIELD, VENT..... UCO: BVY, B15, B20, B24, B25, C17, NNN	1

END OF FIGURE

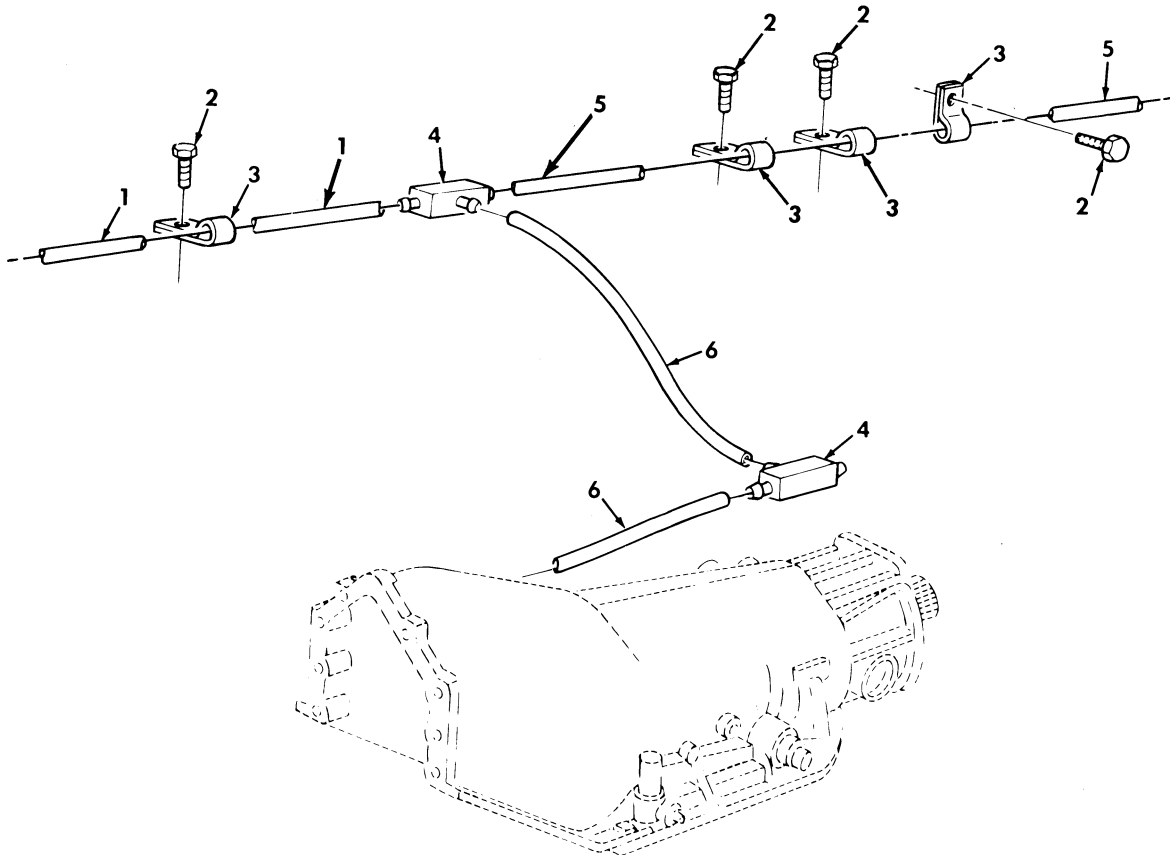

Figure 123. Transmission Vent Lines and Attaching Hardware.

SECTION II			TM9-2320-280-24P			
(1)	(2)	(3)	(4)	(5)	(6)	(7)
ITEM	SMR			PART		
NO	CODE	NSN	CAGEC	NUMBER	DESCRIPTION AND USABLE ON CODES(UC)	QTY
GROUP 0721 COOLERS,PUMPS,MOTORS						
FIG. 123 TRANSMISSION VENT LINES AND ATTACHING HARDWARE						
1	MOOZZ		34623	5591253	TUBE MAKE FROM TUBE, P/N CPR104420-1, 41 INCHES LONG.....	1
2	PAOZZ	5305012364349	7X677	172482	SCREW,TAPPING 3/8-16 X .62.....	4
3	PAOZZ	5340000509077	96906	MS21333-119	CLAMP,LOOP.....	4
4	PAOZZ	4730010035105	79470	1064X4	TEE,HOSE.....	2
5	MOOZZ		34623	5591168	TUBE MAKE FROM TUBE, P/N CPR104420-1, 64 INCHES LONG.....	1
6	MOOZZ		34623	5582642	TUBE MAKE FROM TUBE, P/N CPR104420-1, 11 INCHES LONG.....	2

END OF FIGURE

**USE WITH BASIC AND A1 VEHICLES**

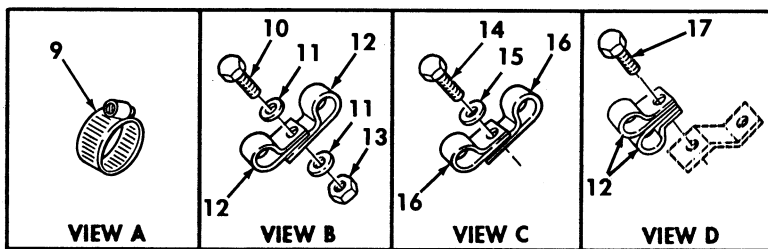
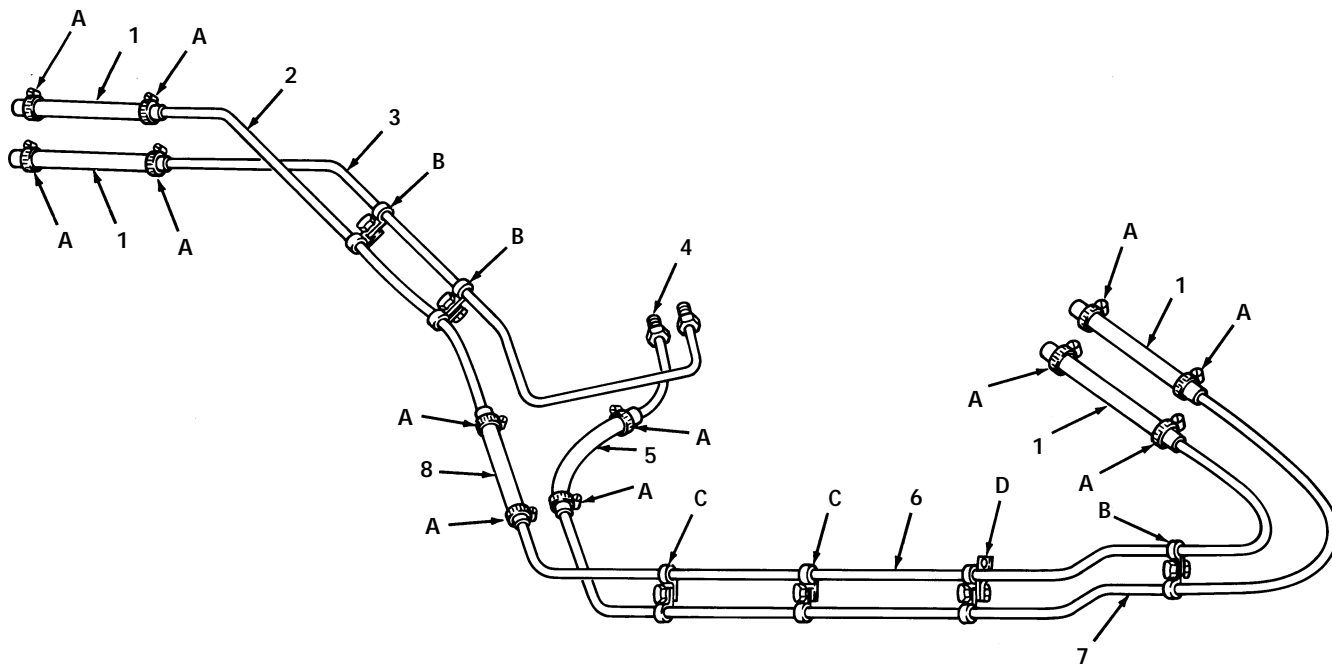

Figure 124. Transmission/Transfer Cooling Lines.



SECTION II			TM9-2320-280-24P			
(1)	(2)	(3)	(4)	(5)	(6)	(7)
ITEM NO	SMR CODE	NSN	CAGEC	PART NUMBER	DESCRIPTION AND USABLE ON CODES(UC)	QTY
GROUP 0721 COOLERS,PUMPS,MOTORS						
FIG. 124 TRANSMISSION/TRANSFER COOLING LINES						
1	MOOZZ		34623	5582479	HOSE MAKE FROM HOSE,P/N 6490610019, 3 INCHES LONG..... UOC:AVY,A11,A13,A14,A15,A20,A24,A25, A26,A27,B16,B17,B18,HVY,H11,H13,H14, H15,H16,H17,H18,H20,H21,H24,H25,H26, H27,H28,MMM	4
2	PAOZZ	4710011890705	34623	12338333	TUBE,BENT,METALLIC REAR..... UOC:AVY,A11,A13,A14,A15,A20,A24,A25, A26,A27,B16,B17,B18,HVY,H11,H13,H14, H15,H16,H17,H18,H20,H21,H24,H25,H26, H27,H28,MMM	1
3	PAOZZ	4710011888780	34623	5583650	TUBE ASSEMBLY,METAL..... UOC:AVY,A11,A13,A14,A15,A20,A24,A25, A26,A27,B16,B17,B18,HVY,H11,H13,H14, H15,H16,H17,H18,H20,H21,H24,H25,H26, H27,H28,MMM	1
4	PAOZZ	4710011891080	34623	5582815	TUBE ASSEMBLY,METAL REAR..... UOC:AVY,A11,A13,A14,A15,A20,A24,A25, A26,A27,B16,B17,B18,HVY,H11,H13,H14, H15,H16,H17,H18,H20,H21,H24,H25,H26, H27,H28,MMM	1
5	MOOZZ		34623	5591937	HOSE MAKE FROM HOSE,P/N 6490610019, 7.25 INCHES LONG..... UOC:AVY,A11,A13,A14,A15,A20,A24,A25, A26,A27,B16,B17,B18,HVY,H11,H13,H14, H15,H16,H17,H18,H20,H21,H24,H25,H26, H27,H28,MMM	1
6	PAOZZ	4710011883516	34623	5582817	TUBE,BENT,METALLIC FRONT..... UOC:AVY,A11,A13,A14,A15,A20,A24,A25, A26,A27,B16,B17,B18,HVY,H11,H13,H14, H15,H16,H17,H18,H20,H21,H24,H25,H26, H27,H28,MMM	1
7	PAOZZ	4710011883515	34623	5582819	TUBE,BENT,METALLIC FRONT..... UOC:AVY,A11,A13,A14,A15,A20,A24,A25, A26,A27,B16,B17,B18,HVY,H11,H13,H14, H15,H16,H17,H18,H20,H21,H24,H25,H26, H27,H28,MMM	1
8	MOOZZ		34623	5591938	HOSE MAKE FROM HOSE,P/N 6490610019, 10 INCHES LONG..... UOC:AVY,A11,A13,A14,A15,A20,A24,A25, A26,A27,B16,B17,B18,HVY,H11,H13,H14, H15,H16,H17,H18,H20,H21,H24,H25,H26, H27,H28,MMM	1
9	PAOZZ	4730011188278	76599	MMF4-SS	CLAMP,HOSE..... UOC:AVY,A11,A13,A14,A15,A20,A24,A25, A26,A27,B16,B17,B18,HVY,H11,H13,H14, H15,H16,H17,H18,H20,H21,H24,H25,H26, H27,H28,MMM	12

SECTION II			TM9-2320-280-24P			
(1)	(2)	(3)	(4)	(5)	(6)	(7)
ITEM NO	SMR CODE	NSN	CAGEC	PART NUMBER	DESCRIPTION AND USABLE ON CODES(UC)	QTY
10	PAOZZ	5305000680502	96906	MS90725-6	SCREW,CAP,HEXAGON H 1/4-20 X 3/4... UOC:AVY,A11,A13,A14,A15,A20,A24,A25, A26,A27,B16,B17,B18,HVY,H11,H13,H14, H15,H16,H17,H18,H20,H21,H24,H25,H26, H27,H28,MMM	3
11	PAOZZ	5310011023270	24617	2436161	WASHER,FLAT 1/4..... UOC:AVY,A11,A13,A14,A15,A20,A24,A25, A26,A27,B16,B17,B18,HVY,H11,H13,H14, H15,H16,H17,H18,H20,H21,H24,H25,H26, H27,H28,MMM	6
12	PAOZZ	5340010712047	75272	C0V0709Z1	HOOK,SUPPORT..... UOC:AVY,A11,A13,A14,A15,A20,A24,A25, A26,A27,B16,B17,B18,HVY,H11,H13,H14, H15,H16,H17,H18,H20,H21,H24,H25,H26, H27,H28,MMM	8
13	PAOZZ	5310000614650	96906	MS51943-31	NUT,SELF-LOCKING,HE 1/4-20..... UOC:AVY,A11,A13,A14,A15,A20,A24,A25, A26,A27,B16,B17,B18,HVY,H11,H13,H14, H15,H16,H17,H18,H20,H21,H24,H25,H26, H27,H28,MMM	3
14	PAOZZ	5305012364349	7X677	172482	SCREW,TAPPING 3/8-16 X 3/4..... UOC:AVY,A11,A13,A14,A15,A20,A24,A25, A26,A27,B16,B17,B18,HVY,H11,H13,H14, H15,H16,H17,H18,H20,H21,H24,H25,H26, H27,H28,MMM	2
15	PAOZZ	5310006379541	96906	MS35338-46	WASHER,LOCK 3/8..... UOC:AVY,A11,A13,A14,A15,A20,A24,A25, A26,A27,B16,B17,B18,HVY,H11,H13,H14, H15,H16,H17,H18,H20,H21,H24,H25,H26, H27,H28,MMM	2
16	PAOZZ	5340009546014	96906	MS21333-121	CLAMP,LOOP..... UOC:AVY,A11,A13,A14,A15,A20,A24,A25, A26,A27,B16,B17,B18,HVY,H11,H13,H14, H15,H16,H17,H18,H20,H21,H24,H25,H26, H27,H28,MMM	4
17	PAOZZ	5305010846067	96906	MS51871-1	SCREW,TAPPING 1/4-20 X 1/2..... UOC:AVY,A11,A13,A14,A15,A20,A24,A25, A26,A27,B16,B17,B18,HVY,H11,H13,H14, H15,H16,H17,H18,H20,H21,H24,H25,H26, H27,H28,MMM	1

END OF FIGURE

**USE WITH A2 VEHICLES**

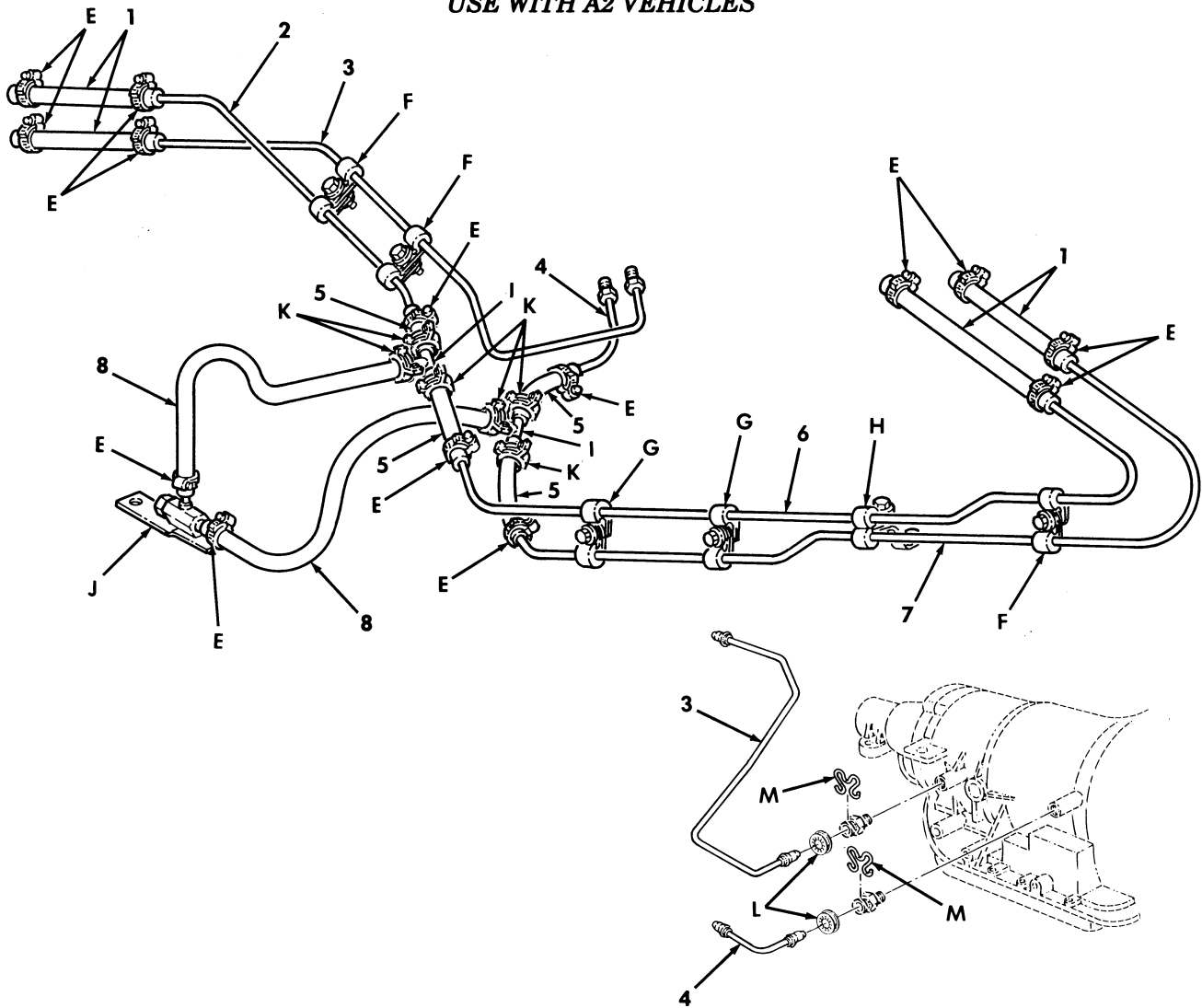





 <p><b>VIEW E</b></p>	 <p><b>VIEW F</b></p>	 <p><b>VIEW G</b></p>	 <p><b>VIEW H</b></p>	 <p><b>VIEW I</b></p>	 <p><b>VIEW J</b></p>	 <p><b>VIEW K</b></p>
 <p><b>VIEW L</b></p>	 <p><b>VIEW M</b></p>					

Figure 125. Transmission/Transfer Cooling Lines.

SECTION II			TM9-2320-280-24P			
(1)	(2)	(3)	(4)	(5)	(6)	(7)
ITEM NO	SMR CODE	NSN	CAGEC	PART NUMBER	DESCRIPTION AND USABLE ON CODES(UCO)	QTY
GROUP 0721 COOLERS,PUMPS,MOTORS						
FIG. 125 TRANSMISSION/TRANSFER COOLING LINES						
1	MOOZZ		19207	12338330-1	HOSE, NONMETALLIC MAKE FROM HOSE, P/N 6490610019, 3 INCHES LONG.....	4
					UCO: BVY, B15, B20, B24, B25, C17, NNN	
2	PAOZZ	4710011890705	34623	12338333	TUBE, BENT, METALLIC.....	1
					UCO: BVY, B15, B20, B24, B25, C17, NNN	
3	PAOZZ	4710014092508	34623	6002779	TUBE ASSEMBLY, METAL 1995, 96.....	1
					UCO: BVY, B15, B20, B24, B25, C17, NNN	
3	PAOZZ	4710014398167	19207	12460493	TUBE, BENT, METALLIC 1997, 98.....	1
					UCO: BVY, B15, B20, B24, B25, C17, NNN	
4	PAOZZ	4710014092504	34623	6002771	TUBE ASSEMBLY, METAL 1995, 96.....	1
					UCO: BVY, B15, B20, B24, B25, C17, NNN	
4	PAOZZ	4710014398165	19207	12460492	TUBE, BENT, METALLIC 1997, 98.....	1
					UCO: BVY, B15, B20, B24, B25, C17, NNN	
5	MOOZZ		19207	12447073-4	HOSE MAKE FROM HOSE, P/N 6490610019, 4 INCHES LONG.....	4
					UCO: BVY, B15, B20, B24, B25, C17, NNN	
6	PAOZZ	4710011883515	34623	5582819	TUBE, BENT, METALLIC.....	1
					UCO: BVY, B15, B20, B24, B25, C17, NNN	
7	PAOZZ	4710011883516	34623	5582817	TUBE, BENT, METALLIC.....	1
					UCO: BVY, B15, B20, B24, B25, C17, NNN	
8	MOOZZ		34623	12338330-2	HOSE, NONMETALLIC MAKE FROM HOSE, P/N 6490610019, 7.25 INCHES LONG.....	2
					UCO: BVY, B15, B20, B24, B25, C17, NNN	
9	PAOZZ	4730014138244	34623	11608950-1	CLAMP, HOSE.....	20
					UCO: BVY, B15, B20, B24, B25, C17, NNN	
10	PAOZZ	5305000680502	96906	MS90725-6	SCREW, CAP, HEXAGON H.....	3
					UCO: BVY, B15, B20, B24, B25, C17, NNN	
11	PAOZZ	5310011023270	24617	2436161	WASHER, FLAT.....	6
					UCO: BVY, B15, B20, B24, B25, C17, NNN	
12	PAOZZ	5340008091492	81348	CMDX2-3PT573036	CLAMP, LOOP.....	8
					UCO: BVY, B15, B20, B24, B25, C17, NNN	
13	PAOZZ	5310000614650	96906	MS51943-31	NUT, SELF-LOCKING, HE.....	4
					UCO: BVY, B15, B20, B24, B25, C17, NNN	
14	PAOZZ	5305012364349	7X677	172482	SCREW, TAPPING.....	2
					UCO: BVY, B15, B20, B24, B25, C17, NNN	
15	PAOZZ	5310006379541	96906	MS35338-46	WASHER, LOCK.....	2
					UCO: BVY, B15, B20, B24, B25, C17, NNN	
16	PAOZZ	5340009546014	96906	MS21333-121	CLAMP, LOOP.....	4
					UCO: BVY, B15, B20, B24, B25, C17, NNN	
17	PAOZZ	5305010846067	96906	MS51871-1	SCREW, TAPPING.....	1
					UCO: BVY, B15, B20, B24, B25, C17, NNN	
18	PAOZZ	4730014091204	34623	12447077	TEE, HOSE.....	1
					UCO: BVY, B15, B20, B24, B25, C17, NNN	
19	PAOZZ	4820014566257	19207	12447076	VALVE, REGULATING, FL.....	1
					UCO: BVY, B15, B20, B24, B25, C17, NNN	
20	PAOZZ	4730001422010	17576	AA52506	CLAMP.....	6
					UCO: BVY, B15, B20, B24, B25, C17, NNN	
21	PAOZZ	5340014420308	19207	12460491	COVER, ACCESS 1997, 98.....	2

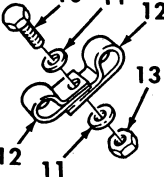
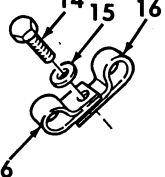
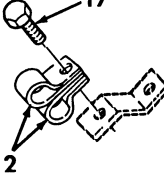
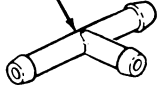
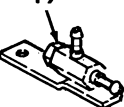
SECTION II			TM9-2320-280-24P			
(1)	(2)	(3)	(4)	(5)	(6)	(7)
ITEM	SMR			PART		
NO	CODE	NSN	CAGEC	NUMBER	DESCRIPTION AND USABLE ON CODES(UC)	QTY
22	PAOZZ	5340014744011	7X677	24205103	UC:BVY,B15,B20,B24,B25,C17,NNN CLIP,RETAINER 1997,98.....	2
					UC:BVY,B15,B20,B24,B25,C17,NNN	

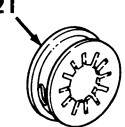
END OF FIGURE

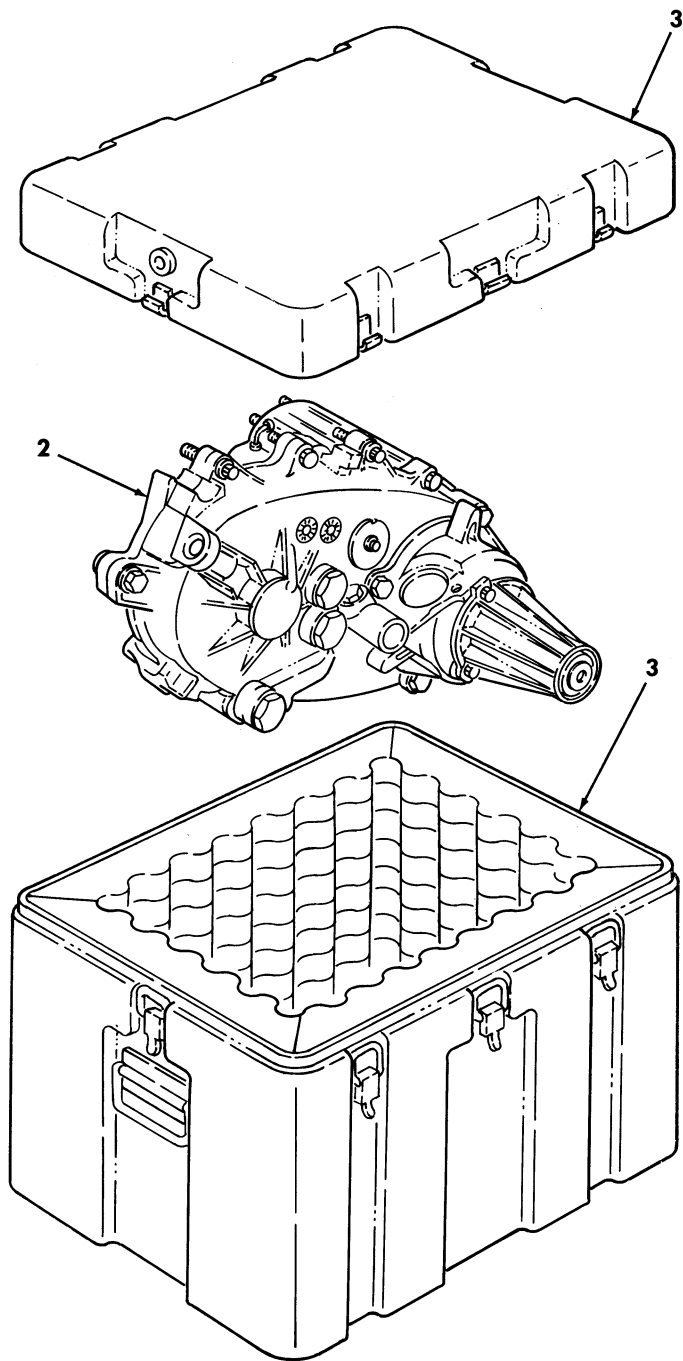
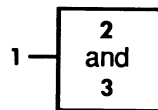
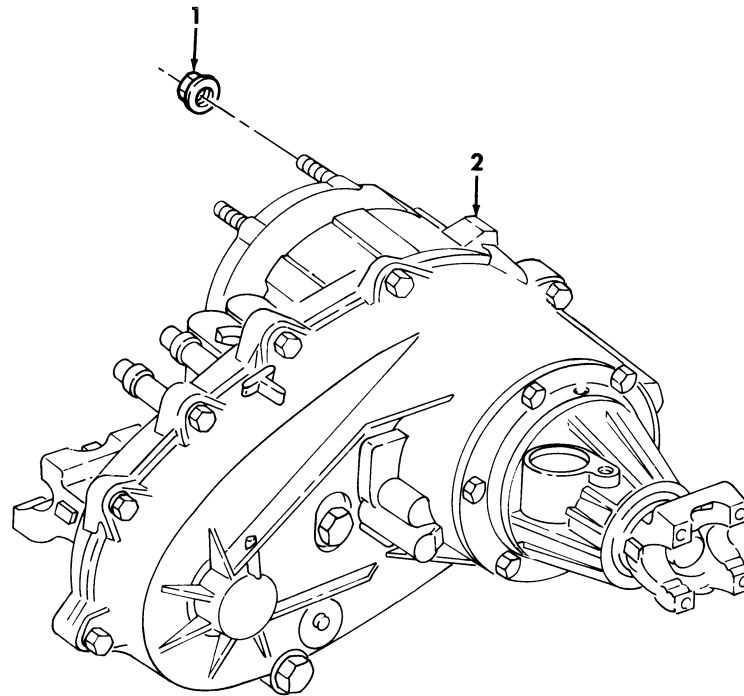

Figure 126. Transfer Case, W/Container.

SECTION II			TM9-2320-280-24P			
(1)	(2)	(3)	(4)	(5)	(6)	(7)
ITEM	SMR			PART		
NO	CODE	NSN	CAGEC	NUMBER	DESCRIPTION AND USABLE ON CODES(UOC)	QTY
GROUP 14 STEERING						
0801 TRANSFER ASSEMBLY						
FIG. 126 TRANSFER CASE,W/CONTAINER						
1	PAFHH	2520014699893	19207	57K3505	TRANSFER AND CONTAI 12447125,W/ CONTAINER..... UOC:BVY,B15,B20,B24,B25,C17,H11,H13, H14,H15,H16,H17,H18,H20,H21,H24,H25, H26,H27,H28,MMM,NNN	1
1	PAFHH	2520014735029	19207	57K3506	TRANSFER TRANSMISSI 12340073-1,W/ CONTAINER..... UOC:H11,H13,H14,H15,H16,H17,H18,H20, H21,H24,H25,H26,H27,H28,MMM	1
1	PAFHH	2520014528365	19207	57K3507	TRANSFER AND CONTAI..12342643-1,W/ CONTAINER..... UOC:AVY,A11,A13,A14,A15,A20,A24,A25, A26,A27,B16,B17,B18,HVY	1
2	PAFHH	2520014527569	19207	12342643-1	.TRANSFER TRANSMISSI..... UOC:AVY,A11,A13,A14,A15,A20,A24,A25, A26,A27,B16,B17,B18,HVY	1
2	PAFHH	2520011634999	19207	12340073-1	.TRANSFER TRANSMISSI..... UOC:H11,H13,H14,H15,H16,H17,H18,H20, H21,H24,H25,H26,H27,H28,MMM	1
2	PAFHH	2520014092512	19207	12447125	.TRANSFER TRANSMISSI..... UOC:BVY,B15,B20,B24,B25,C17,H11,H13, H14,H15,H16,H17,H18,H20,H21,H24,H25, H26,H27,H28,MMM,NNN	1
3	PAFZZ	8145004858250	80132	13414-077	.CONTAINER.....	1

END OF FIGURE



**FOR BREAKDOWN OF ITEM 2  
SEE FIGURE 128**

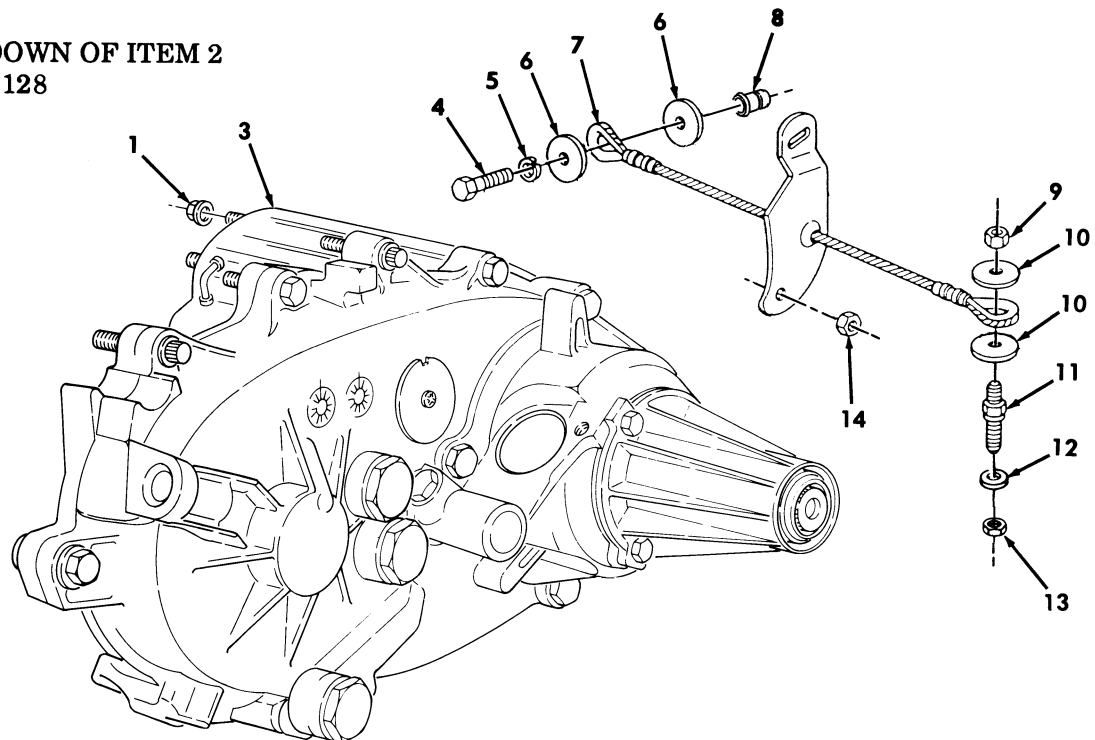

**FOR BREAKDOWN OF ITEM 4  
SEE FIGURES 129 AND 130**

*Figure 127. Transfer Assembly.*



SECTION II			TM9-2320-280-24P			
(1)	(2)	(3)	(4)	(5)	(6)	(7)
ITEM NO	SMR CODE	NSN	CAGEC	PART NUMBER	DESCRIPTION AND USABLE ON CODES(UOC)	QTY
GROUP 0801 POWER TRANSFER,FINAL DRIVE,PLANETARY OR DROP BOX ASSEMBLY						
FIG. 127 TRANSFER ASSEMBLY						
1	PAFZZ	5310004478774	96906	MS51988-8	NUT,SELF-LOCKING,EX 3/8-24.....	6
2	PAFHH	2520011634999	19207	12340073-1	TRANSFER TRANSMISSI.....	1
					UOC:H11,H13,H14,H15,H16,H17,H18,H20,H21,H24,H25,H26,H27,H28,MMM	
3	PAFHH	2520013569197	34623	5937387	TRANSFER TRANSMISSI.....	1
					UOC:AVY,A11,A13,A14,A15,A20,A24,A25,A26,A27,B16,B17,B18,HVY	
3	PAFHH	2520014092512	19207	12447125	TRANSFER TRANSMISSI THIS TRANSFER FITS BASIC VEHICLE ONLY WHEN KIT P/N 57K3498 IS INSTALLED.....	1
					UOC:BVY,B15,B20,B24,B25,C17,H11,H13,H14,H15,H16,H17,H18,H20,H21,H24,H25,H26,H27,H28,MMM,NNN	
3	PAFHH	2520014527569	19207	12342643-1	TRANSFER TRANSMISSI.....	1
					UOC:AVY,A11,A13,A14,A15,A20,A24,A25,A26,A27,B16,B17,B18,HVY	
4	PAFZZ	5305000712070	80204	B1821BH050C175N	SCREW,CAP,HEXAGON H 1/2-13 X 1.75..	1
					UOC:BVY,B15,B20,B24,B25,C17,NNN	
5	PAFZZ	5310000116121	29510	120384	WASHER,LOCK.....	1
					UOC:BVY,B15,B20,B24,B25,C17,NNN	
6	PAFZZ	5310014089593	7X677	9428839	WASHER,FLAT.....	2
					UOC:BVY,B15,B20,B24,B25,C17,NNN	
7	PAFZZ	3040014393662	19207	12447180	WIRE ROPE ASSEMBLY.....	1
					UOC:BVY,B15,B20,B24,B25,C17,NNN	
8	PAFZZ	5325014090211	78276	ATS2-813	INSERT,SCREW,THREAD.....	1
					UOC:BVY,B15,B20,B24,B25,C17,NNN	
9	PAFZZ	5310011504003	24617	9422299	NUT,SELF-LOCKING,HE.....	1
					UOC:BVY,B15,B20,B24,B25,C17,NNN	
10	PAFZZ	5310012538437	19207	12340058	WASHER,FLAT.....	2
					UOC:BVY,B15,B20,B24,B25,C17,NNN	
11	PAFZZ	5307014503072	19207	12447177	STUD.....	1
					UOC:BVY,B15,B20,B24,B25,C17,NNN	
12	PAFZZ	5310000685285	24617	2436166	WASHER,FLAT.....	1
					UOC:BVY,B15,B20,B24,B25,C17,NNN	
13	PAFZZ	5310000443342	24617	9422303	NUT.....	1
					UOC:BVY,B15,B20,B24,B25,C17,NNN	
14	PAFZZ	5310011430512	73342	11501033	NUT.....	1
					UOC:BVY,B15,B20,B24,B25,C17,NNN	

END OF FIGURE

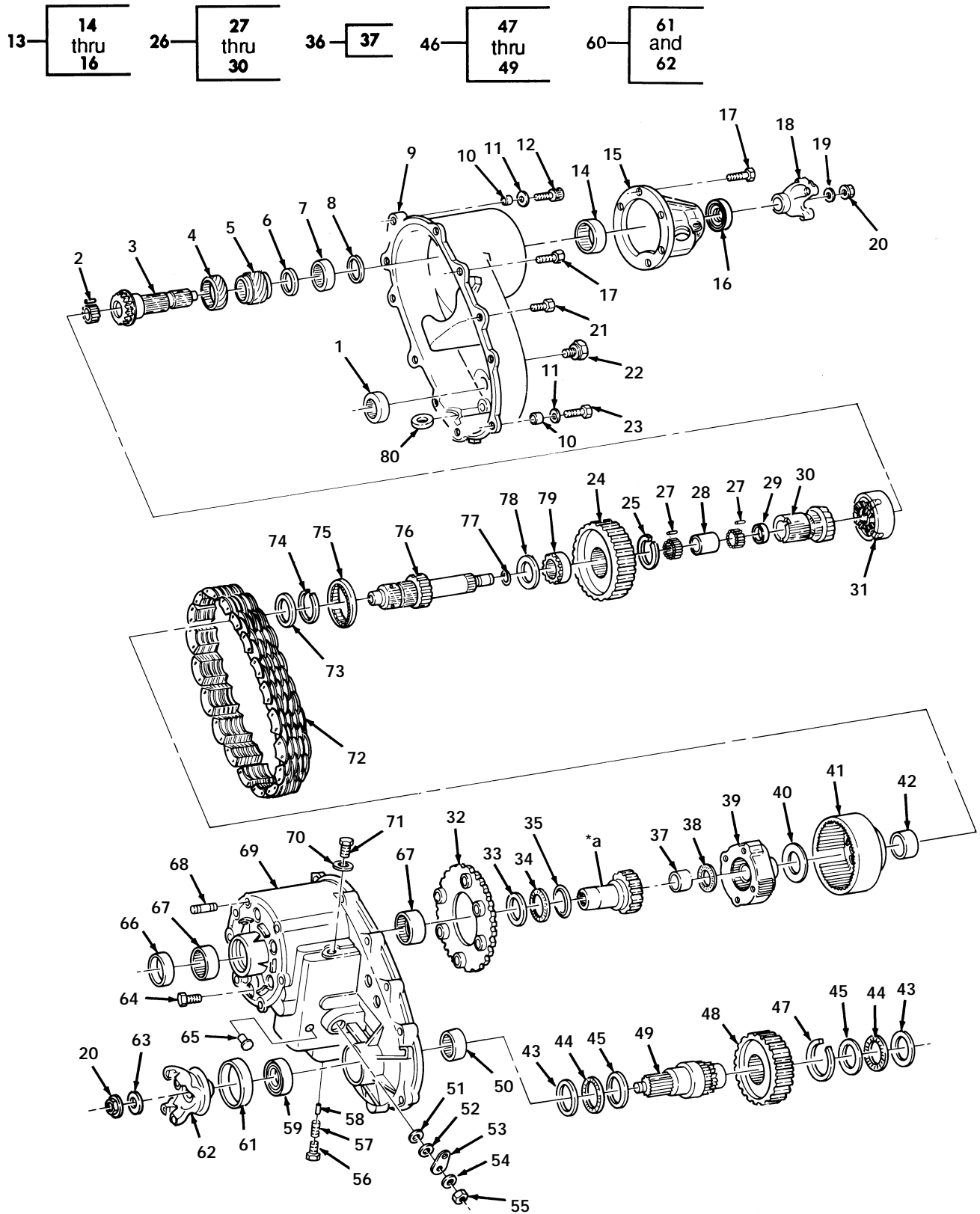

\* a PART OF ITEM 36

Figure 128. Transfer Case Assembly, P/N 12340073-1.

SECTION II			TM9-2320-280-24P			
(1)	(2)	(3)	(4)	(5)	(6)	(7)
ITEM	SMR			PART		
NO	CODE	NSN	CAGEC	NUMBER	DESCRIPTION AND USABLE ON CODES(UC)	QTY
					GROUP 0801 POWER TRANSFER,FINAL DRIVE,PLANETARY OR DROP GEAR BOX ASSEMBLY	
					FIG. 128 TRANSFER CASE ASSEMBLY, P/N 12340073-1	
1	PAHZZ	3110011554440	27737	SCE-2416	BEARING,ROLLER,NEED FRONT.....	1
					UOC:H11,H13,H14,H15,H16,H17,H18,H20, H21,H24,H25,H26,H27,H28,MMM	
2	PAHZZ	3110006894076	21335	QAR29523	ROLLER,BEARING REAR.....	15
					UOC:H11,H13,H14,H15,H16,H17,H18,H20, H21,H24,H25,H26,H27,H28,MMM	
3	XAHZZ		34623	5740519	SHAFT REAR.....	1
					UOC:H11,H13,H14,H15,H16,H17,H18,H20, H21,H24,H25,H26,H27,H28,MMM	
4	PAHZZ	2520011899750	34623	5740018	OIL PUMP,TRANSMISSI.....	1
					UOC:H11,H13,H14,H15,H16,H17,H18,H20, H21,H24,H25,H26,H27,H28,MMM	
5	PAHZZ	2520011749291	34623	5740233	GEAR,SPEEDOMETER.....	1
					UOC:H11,H13,H14,H15,H16,H17,H18,H20, H21,H24,H25,H26,H27,H28,MMM	
6	KFHZZ		34623	5740520	SHIM .004 PART OF KIT P/N 5740228..	1
					UOC:H11,H13,H14,H15,H16,H17,H18,H20, H21,H24,H25,H26,H27,H28,MMM	
6	KFHZZ		34623	5740521	SHIM .005 PART OF KIT P/N 5740228..	1
					UOC:H11,H13,H14,H15,H16,H17,H18,H20, H21,H24,H25,H26,H27,H28,MMM	
6	KFHZZ		34623	5740522	SHIM .0125 PART OF KIT P/N 5740228..	1
					UOC:H11,H13,H14,H15,H16,H17,H18,H20, H21,H24,H25,H26,H27,H28,MMM	
6	KFHZZ		34623	5740523	SHIM .015 PART OF KIT P/N 5740228..	1
					UOC:H11,H13,H14,H15,H16,H17,H18,H20, H21,H24,H25,H26,H27,H28,MMM	
6	KFHZZ		34623	5740524	SHIM .042 PART OF KIT P/N 5740228..	1
					UOC:H11,H13,H14,H15,H16,H17,H18,H20, H21,H24,H25,H26,H27,H28,MMM	
6	KFHZZ		34623	5740525	SHIM .062 PART OF KIT P/N 5740228..	1
					UOC:H11,H13,H14,H15,H16,H17,H18,H20, H21,H24,H25,H26,H27,H28,MMM	
7	PAHZZ	3110000569376	96906	MS17131-55	BEARING,ROLLER,NEED REAR.....	1
					UOC:H11,H13,H14,H15,H16,H17,H18,H20, H21,H24,H25,H26,H27,H28,MMM	
8	PAHZZ	5330004974633	73680	71X6284	SEAL,PLAIN ENCASED.....	1
					UOC:H11,H13,H14,H15,H16,H17,H18,H20, H21,H24,H25,H26,H27,H28,MMM	
9	PFHZZ	2520012063877	34623	5740514	HOUSING,TRANSMISSIO REAR.....	1
					UOC:H11,H13,H14,H15,H16,H17,H18,H20, H21,H24,H25,H26,H27,H28,MMM	
10	PAHZZ	5315011604642	7X677	14037948	PIN,SPRING.....	2
					UOC:H11,H13,H14,H15,H16,H17,H18,H20, H21,H24,H25,H26,H27,H28,MMM	
11	PAHZZ	5310011748158	34623	5740230	WASHER,FLAT.....	2

SECTION II			TM9-2320-280-24P			
(1)	(2)	(3)	(4)	(5)	(6)	(7)
ITEM	SMR			PART		
NO	CODE	NSN	CAGEC	NUMBER	DESCRIPTION AND USABLE ON CODES(UC)	QTY
12	PAHZZ	5305012097667	34623	5741074	UOC:H11,H13,H14,H15,H16,H17,H18,H20, H21,H24,H25,H26,H27,H28,MMM SCREW.....	1
13	PAHZZ	2520011756401	34623	5740119	UOC:H11,H13,H14,H15,H16,H17,H18,H20, H21,H24,H25,H26,H27,H28,MMM RETAINER ASSEMBLY REAR.....	1
14	PAHZZ	3110001556152	73342	907425	UOC:H11,H13,H14,H15,H16,H17,H18,H20, H21,H24,H25,H26,H27,H28,MMM .BEARING,BALL,ANNULA OUTER.....	1
15	PFHZZ	3040012063876	76760	16064	UOC:H11,H13,H14,H15,H16,H17,H18,H20, H21,H24,H25,H26,H27,H28,MMM .HOUSING,MECHANICAL.....	1
16	PAOZZ	5330011479698	34623	5740124	UOC:H11,H13,H14,H15,H16,H17,H18,H20, H21,H24,H25,H26,H27,H28,MMM .SEAL,PLAIN ENCASED.....	1
17	PAHZZ	5305012097668	34623	5741075	UOC:H11,H13,H14,H15,H16,H17,H18,H20, H21,H24,H25,H26,H27,H28,MMM SCREW,SPECIAL.....	3
18	PAOZZ	2520011749554	76760	13766	UOC:H11,H13,H14,H15,H16,H17,H18,H20, H21,H24,H25,H26,H27,H28,MMM YOKE,UNIVERSAL JOIN REAR.....	1
19	PAOZZ	5310011865237	86403	4210973	UOC:H11,H13,H14,H15,H16,H17,H18,H20, H21,H24,H25,H26,H27,H28,MMM WASHER,LOCK FRONT AND REAR.....	1
20	PAOZZ	5310011748091	82978	4167924	UOC:H11,H13,H14,H15,H16,H17,H18,H20, H21,H24,H25,H26,H27,H28,MMM NUT,PLAIN,ASSEM. FRONT AND REAR....	2
21	PAHZZ	5306011524696	24617	11503428	UOC:H11,H13,H14,H15,H16,H17,H18,H20, H21,H24,H25,H26,H27,H28,MMM BOLT,SELF-LOCKING FRONT AND REAR...	12
22	PAOZZ	5365014469408	76760	22398	UOC:H11,H13,H14,H15,H16,H17,H18,H20, H21,H24,H25,H26,H27,H28,MMM PLUG,MACHINE THREAD.....	2
23	PAHZZ	5306011654283	24617	11500831	UOC:H11,H13,H14,H15,H16,H17,H18,H20, H21,H24,H25,H26,H27,H28,MMM BOLT,SELF-LOCKING.....	1
24	PAHZZ	3020011775441	34623	5740512	UOC:H11,H13,H14,H15,H16,H17,H18,H20, H21,H24,H25,H26,H27,H28,MMM SPROCKET WHEEL.....	1
25	PAHZZ	5325011576764	7X677	14037981	UOC:H11,H13,H14,H15,H16,H17,H18,H20, H21,H24,H25,H26,H27,H28,MMM RING,RETAINING.....	1
26	PAHZZ	2520011749287	34623	5740222	UOC:H11,H13,H14,H15,H16,H17,H18,H20, H21,H24,H25,H26,H27,H28,MMM GEAR ASSEMBLY,TRANS.....	1
27	KFHZZ		7X677	9434068	UOC:H11,H13,H14,H15,H16,H17,H18,H20, H21,H24,H25,H26,H27,H28,MMM .ROLLER,BEARING PART OF KIT P/N 5740229.....	82
28	PAHZZ	5365011748154	34623	5740219	UOC:H11,H13,H14,H15,H16,H17,H18,H20, H21,H24,H25,H26,H27,H28,MMM .SPACER,SLEEVE.....	1

SECTION II			TM9-2320-280-24P			
(1)	(2)	(3)	(4)	(5)	(6)	(7)
ITEM	SMR			PART		
NO	CODE	NSN	CAGEC	NUMBER	DESCRIPTION AND USABLE ON CODES(UOC)	QTY
29	PAHZZ	5365011748185	34623	5740100	H21, H24, H25, H26, H27, H28, MMM . SPACER, RING REAR.....	1
					UOC:H11, H13, H14, H15, H16, H17, H18, H20, H21, H24, H25, H26, H27, H28, MMM	
30	XAHZZ		34623	5740517	. SIDE, GEAR.....	1
					UOC:H11, H13, H14, H15, H16, H17, H18, H20, H21, H24, H25, H26, H27, H28, MMM	
31	PAHZZ	2520011749288	34623	5740279	DIFFERENTIAL, TRANSF.....	1
					UOC:H11, H13, H14, H15, H16, H17, H18, H20, H21, H24, H25, H26, H27, H28, MMM	
32	PAHZZ	3020011756477	34623	5740108	GEAR, SPUR.....	1
					UOC:H11, H13, H14, H15, H16, H17, H18, H20, H21, H24, H25, H26, H27, H28, MMM	
33	PAHZZ	3120011748155	34623	5740235	BEARING, WASHER, THRU.....	1
					UOC:H11, H13, H14, H15, H16, H17, H18, H20, H21, H24, H25, H26, H27, H28, MMM	
34	PAHZZ	3120011748631	34623	5740236	BEARING, WASHER, THRU.....	1
					UOC:H11, H13, H14, H15, H16, H17, H18, H20, H21, H24, H25, H26, H27, H28, MMM	
35	PAHZZ	3120011748630	34623	5740237	BEARING, WASHER, THRU.....	1
					UOC:H11, H13, H14, H15, H16, H17, H18, H20, H21, H24, H25, H26, H27, H28, MMM	
36	PAHZZ	3040011772428	34623	5740093	GEARSHAFT, SPUR.....	1
					UOC:H11, H13, H14, H15, H16, H17, H18, H20, H21, H24, H25, H26, H27, H28, MMM	
37	PAHZZ	3110011559862	27737	SCE-2012	. BEARING, ROLLER, NEED.....	1
					UOC:H11, H13, H14, H15, H16, H17, H18, H20, H21, H24, H25, H26, H27, H28, MMM	
38	PAHZZ	3110005803843	89326	NTA2435	RETAINER AND ROLLER.....	1
					UOC:H11, H13, H14, H15, H16, H17, H18, H20, H21, H24, H25, H26, H27, H28, MMM	
39	PAHZZ	3010011760557	34623	5740104	CARRIER, GEAR ASSEMB.....	1
					UOC:H11, H13, H14, H15, H16, H17, H18, H20, H21, H24, H25, H26, H27, H28, MMM	
40	PAHZZ	3120011554470	7X677	14095677	BEARING, WASHER, THRU.....	1
					UOC:H11, H13, H14, H15, H16, H17, H18, H20, H21, H24, H25, H26, H27, H28, MMM	
41	PAHHH	3020011489548	34623	5740105	GEAR, INTERNAL.....	1
					UOC:H11, H13, H14, H15, H16, H17, H18, H20, H21, H24, H25, H26, H27, H28, MMM	
42	PAHZZ	3120011553509	7X677	14044937	BEARING, SLEEVE.....	1
					UOC:H11, H13, H14, H15, H16, H17, H18, H20, H21, H24, H25, H26, H27, H28, MMM	
43	PAHZZ	3120011558713	34623	5740109	BEARING, WASHER, THRU.....	2
					UOC:H11, H13, H14, H15, H16, H17, H18, H20, H21, H24, H25, H26, H27, H28, MMM	
44	PAHZZ	3110007562022	21335	NTA2840	RETAINER AND ROLLER.....	2
					UOC:H11, H13, H14, H15, H16, H17, H18, H20, H21, H24, H25, H26, H27, H28, MMM	
45	PAHZZ	3110000552100	60380	TRA 2840	SEAT, BEARING.....	2
					UOC:H11, H13, H14, H15, H16, H17, H18, H20, H21, H24, H25, H26, H27, H28, MMM	
46	PAHZZ	3040011772427	34623	5740092	GEARSHAFT, SPUR FRONT.....	1

SECTION II			TM9-2320-280-24P			
(1)	(2)	(3)	(4)	(5)	(6)	(7)
ITEM	SMR			PART		
NO	CODE	NSN	CAGEC	NUMBER	DESCRIPTION AND USABLE ON CODES(UC)	QTY
47	PAHZZ	5325011576764	7X677	14037981	UOC:H11,H13,H14,H15,H16,H17,H18,H20, H21,H24,H25,H26,H27,H28,MMM .RING,RETAINING FRONT.....	1
48	PFHZZ	3020011775441	34623	5740512	UOC:H11,H13,H14,H15,H16,H17,H18,H20, H21,H24,H25,H26,H27,H28,MMM .SPROCKET WHEEL FRONT.....	1
49	XAHZZ		34623	5740526	UOC:H11,H13,H14,H15,H16,H17,H18,H20, H21,H24,H25,H26,H27,H28,MMM .SHAFT FRONT OUTER.....	1
50	PAHZZ	3110004363248	29930	865168R91	UOC:H11,H13,H14,H15,H16,H17,H18,H20, H21,H24,H25,H26,H27,H28,MMM BEARING,ROLLER,NEED.....	1
51	PAHZZ	5331004510118	10988	A27365	UOC:H11,H13,H14,H15,H16,H17,H18,H20, H21,H24,H25,H26,H27,H28,MMM O-RING.....	1
52	PAHZZ	5330011592811	7X677	14037958	UOC:H11,H13,H14,H15,H16,H17,H18,H20, H21,H24,H25,H26,H27,H28,MMM RETAINER,PACKING.....	1
53	PAHZZ	3040011769615	34623	5740231	UOC:H11,H13,H14,H15,H16,H17,H18,H20, H21,H24,H25,H26,H27,H28,MMM LEVER,REMOTE CONTRO.....	1
54	PAHZZ	5310000806004	96906	MS27183-14	UOC:H11,H13,H14,H15,H16,H17,H18,H20, H21,H24,H25,H26,H27,H28,MMM WASHER,FLAT FRONT HALF, 3/8.....	1
55	PAHZZ	5310009824908	96906	MS21045-6	UOC:H11,H13,H14,H15,H16,H17,H18,H20, H21,H24,H25,H26,H27,H28,MMM NUT,SELF-LOCKING,HE 3/8-24.....	1
56	PAHZZ	5306011748492	34623	5740505	UOC:H11,H13,H14,H15,H16,H17,H18,H20, H21,H24,H25,H26,H27,H28,MMM BOLT.....	1
57	PAHZA	5360007351126	34623	5740504	UOC:H11,H13,H14,H15,H16,H17,H18,H20, H21,H24,H25,H26,H27,H28,MMM SPRING,HELICAL,COMP.....	1
58	PAHZZ	2520011739673	34623	5740232	UOC:H11,H13,H14,H15,H16,H17,H18,H20, H21,H24,H25,H26,H27,H28,MMM PLUNGER,POPPET.....	1
59	PAOZZ	5330013589532	73680	29960-0511	UOC:H11,H13,H14,H15,H16,H17,H18,H20, H21,H24,H25,H26,H27,H28,MMM SEAL,PLAIN ENCASED.....	1
60	PAOFF	2520011687878	34623	5740013	UOC:H11,H13,H14,H15,H16,H17,H18,H20, H21,H24,H25,H26,H27,H28,MMM YOKE AND SLINGER,TR FRONT.....	1
61	PAOZZ	2520011494993	34623	5740225	UOC:H11,H13,H14,H15,H16,H17,H18,H20, H21,H24,H25,H26,H27,H28,MMM .DEFLECTOR,DIRT AND FRONT.....	1
62	XAOZZ		34623	5740515	UOC:H11,H13,H14,H15,H16,H17,H18,H20, H21,H24,H25,H26,H27,H28,MMM .YOKE,FRONT OUTPUT.....	1
63	PAOZZ	5310011865237	86403	4210973	UOC:H11,H13,H14,H15,H16,H17,H18,H20, H21,H24,H25,H26,H27,H28,MMM WASHER,LOCK FRONT.....	1

SECTION II			TM9-2320-280-24P			
(1)	(2)	(3)	(4)	(5)	(6)	(7)
ITEM	SMR			PART		
NO	CODE	NSN	CAGEC	NUMBER	DESCRIPTION AND USABLE ON CODES(UOC)	QTY
64	PAHZZ	5306011674346	76760	13903	BOLT, SELF-LOCKING..... UOC:H11, H13, H14, H15, H16, H17, H18, H20, H21, H24, H25, H26, H27, H28, MMM	6
65	PAFZZ	5340012906234	76760	00015105	PLUG, LEAKPROOF SEAL..... UOC:H11, H13, H14, H15, H16, H17, H18, H20, H21, H24, H25, H26, H27, H28, MMM	1
66	PAFZZ	5330011683870	34623	5740017	SEAL, PLAIN ENCASED..... UOC:H11, H13, H14, H15, H16, H17, H18, H20, H21, H24, H25, H26, H27, H28, MMM	1
67	PAHZZ	3110011552600	34623	5741076	BEARING, ROLLER, NEED..... UOC:H11, H13, H14, H15, H16, H17, H18, H20, H21, H24, H25, H26, H27, H28, MMM	2
68	PAHZZ	5307011748640	34623	5740008	STUD, PLAIN FRONT HALF..... UOC:H11, H13, H14, H15, H16, H17, H18, H20, H21, H24, H25, H26, H27, H28, MMM	6
69	PFHZZ	2520012063875	34623	5740503	HOUSING, TRANSMISSIO..... UOC:H11, H13, H14, H15, H16, H17, H18, H20, H21, H24, H25, H26, H27, H28, MMM	1
70	PAOZZ	5330011554393	7X677	105455	GASKET..... UOC:H11, H13, H14, H15, H16, H17, H18, H20, H21, H24, H25, H26, H27, H28, MMM	1
71	PAOZZ	5365012097713	34623	5741077	PLUG, MACHINE THREAD FRONT HALF..... UOC:H11, H13, H14, H15, H16, H17, H18, H20, H21, H24, H25, H26, H27, H28, MMM	1
72	PAHZZ	2520011789768	34623	5740090	CHAIN ASSEMBLY, TRAN..... UOC:H11, H13, H14, H15, H16, H17, H18, H20, H21, H24, H25, H26, H27, H28, MMM	1
73	PAHZZ	3120011522613	7X677	14095678	BEARING, WASHER, THRU..... UOC:H11, H13, H14, H15, H16, H17, H18, H20, H21, H24, H25, H26, H27, H28, MMM	1
74	PAHZZ	5325011666324	78553	XAN-262-H	RING, RETAINING..... UOC:H11, H13, H14, H15, H16, H17, H18, H20, H21, H24, H25, H26, H27, H28, MMM	1
75	PAHZZ	3020011751962	34623	5740117	GEAR, INTERNAL..... UOC:H11, H13, H14, H15, H16, H17, H18, H20, H21, H24, H25, H26, H27, H28, MMM	1
76	PAHZZ	3040011769584	34623	5740091	GEARSHAFT, SPUR..... UOC:H11, H13, H14, H15, H16, H17, H18, H20, H21, H24, H25, H26, H27, H28, MMM	1
77	PAHZZ	5331011748618	34623	5740099	O-RING..... UOC:H11, H13, H14, H15, H16, H17, H18, H20, H21, H24, H25, H26, H27, H28, MMM	1
78	PAHZZ	3120011748156	34623	5740118	BEARING, WASHER, THRU..... UOC:H11, H13, H14, H15, H16, H17, H18, H20, H21, H24, H25, H26, H27, H28, MMM	1
79	PAHZZ	3020011747810	34623	5740218	GEAR-SLIP CLUTCH, SP..... UOC:H11, H13, H14, H15, H16, H17, H18, H20, H21, H24, H25, H26, H27, H28, MMM	1
80	PAHZZ	2520011597757	7X677	3787240	MAGNET, CHIP COLLECT..... UOC:H11, H13, H14, H15, H16, H17, H18, H20, H21, H24, H25, H26, H27, H28, MMM	1

END OF FIGURE

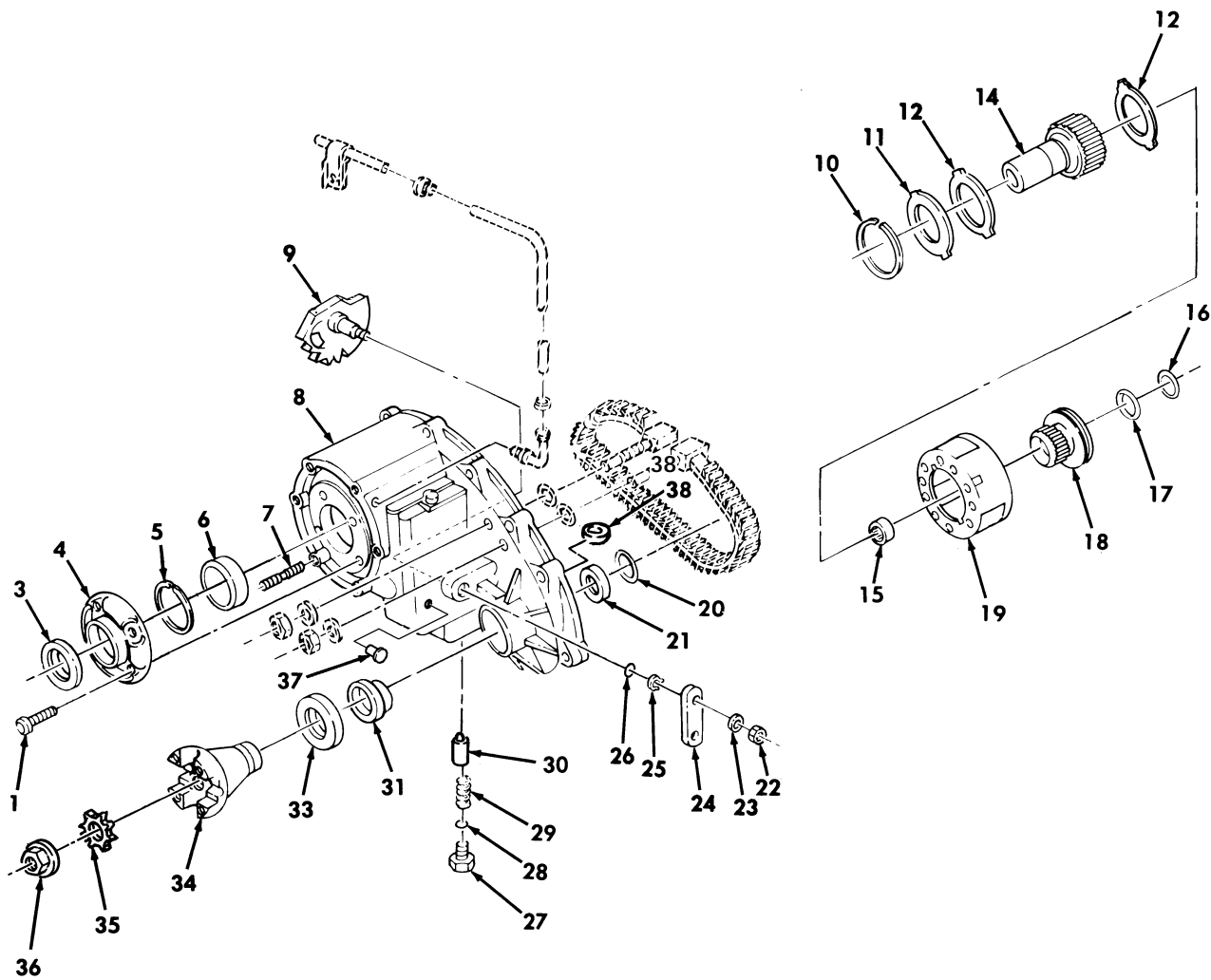
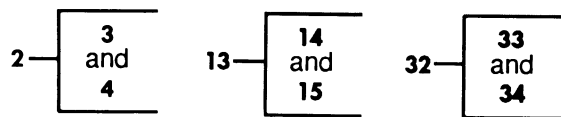

Figure 129. Transfer Case Assembly, P/N 5937387, 12342643-1, and 12447125 (Front Half).



SECTION II			TM9-2320-280-24P			
(1)	(2)	(3)	(4)	(5)	(6)	(7)
ITEM NO	SMR CODE	NSN	CAGEC	PART NUMBER	DESCRIPTION AND USABLE ON CODES(UOC)	QTY
GROUP 0801 TRANSFER ASSEMBLY						
FIG. 129 TRANSFER CASE ASSEMBLY, P/N 5937387,12342643-1,AND 12447125 (FRONT HALF)						
1	PAHZZ	5306013594529	76760	6500318	BOLT,MACHINE.....	4
2	PAHHH	2520013588880	76760	16244	RETAINER ASSEMBLY,I.....	1
3	PAHZZ	5330011683870	34623	5740017	.SEAL,PLAIN ENCASED.....	1
4	XAHZZ		76760	16188	.RETAINER.....	1
5	PAHZZ	5325013585450	76760	16243	RING,RETAINING.....	1
6	PAHZZ	3120013596760	76760	16167	BEARING,SLEEVE USE WITH T-CASE P/N 5937387.....	1
6	PAHZZ	3110014138094	76760	17718	UC:AVY,A11,A13,A14,A15,A20,A24,A25, A26,A27,B16,B17,B18,HVY BEARING,BALL,ANNULA USE WITH T-CASE P/N 12342643-1 AND 12447125.....	1
7	PAHZZ	5307011748640	34623	5740008	STUD,PLAIN.....	6
8	PFHZZ	3040013591116	76760	17292	HOUSING,MECHANICAL USE WITH T-CASE P/N 5937387.....	1
8	PFHZZ	3040014529065	76760	21063	UC:AVY,A11,A13,A14,A15,A20,A24,A25, A26,A27,B16,B17,B18,HVY HOUSING,MECHANICAL USE WITH T-CASE P/N 12342643-1 AND 12447125.....	1
9	PAHZZ	2520013588881	76760	17560	RANGE SECTOR FOR USE WITH T-CASE P/N 5937387.....	1
9	PAHZZ	2520014131900	34623	5743744	UC:AVY,A11,A13,A14,A15,A20,A24,A25, A26,A27,B16,B17,B18,HVY SECTOR ASSEMBLY,TRA FOR USE WITH T- CASE P/N 12342643-1 AND 12447125....	1
10	PAHZZ	5325013587958	76760	16397	RING,RETAINING.....	1
11	PAHZZ	5325012055966	76760	99088C	RING,RETAINING.....	1
12	PAHZZ	3120013601202	34623	5938619	BEARING WASHER,THRU.....	2
13	PAHHH	3040013588690	76760	17381	GEARSHAFT,SPUR USE WITH T-CASE P/N 5937387.....	1
13	PAHHH	2520014131899	76760	21068	UC:AVY,A11,A13,A14,A15,A20,A24,A25, A26,A27,B16,B17,B18,HVY GEAR ASSEMBLY,TRANS USE WITH T-CASE P/N 12447125 AND 12342643-1.....	1
14	XAHZZ		76760	16538	.GEAR,INPUT USE WITH T-CASE P/N 12342643-1 AND 12447125.....	1
14	XAHZZ		76760	17855	.GEAR,INPUT USE WITH T-CASE P/N 5937387.....	1
15	PAHZZ	3130013601050	34623	5938621	UC:AVY,A11,A13,A14,A15,A20,A24,A25, A26,A27,B16,B17,B18,HVY .BEARING UNIT,PLAIN.....	1
16	PAHZZ	5310013585461	76760	16467	WASHER,FLAT.....	1
17	PAHZZ	5325013587959	76760	16466	RING,RETAINING.....	1
18	PAHZZ	3020013591211	76760	16662	SPROCKET WHEEL RANGE CLUTCH USE WITH T-CASE P/N 5937387.....	1
18	PAHZZ	2520014131902	34623	5714229	UC:AVY,A11,A13,A14,A15,A20,A24,A25, A26,A27,B16,B17,B18,HVY SLEEVE,CLUTCH,TRANS USE WITH T-CASE	1

SECTION II			TM9-2320-280-24P			
(1)	(2)	(3)	(4)	(5)	(6)	(7)
ITEM NO	SMR CODE	NSN	CAGEC	PART NUMBER	DESCRIPTION AND USABLE ON CODES(UOC)	QTY
19	PAHZZ	3040013591117	76760	16550	P/N 12342643-1 AND 12447125..... HOUSING,MECHANICAL USE WITH T-CASE P/N 5937387..... UOC:AVY,A11,A13,A14,A15,A20,A24,A25, A26,A27,B16,B17,B18,HVY	1
19	PAHZZ	3010014120673	76760	17869	GEAR UNIT,PLANETARY USE WITH T-CASE P/N 12342643-1 AND 12447125.....	1
20	PAHZZ	5325013587960	76760	89331A	RING,RETAINING.....	1
21	PAHZZ	3130013601051	34623	5938607	BEARING UNIT,PLAIN FRONT.....	1
22	PAHZZ	5310009824908	96906	MS21045-6	NUT,SELF-LOCKING,HE.....	1
23	PAHZZ	5310000806004	96906	MS27183-14	WASHER,FLAT 3/8.....	1
24	PAHZZ	3040013588708	76760	17387	CONNECTING LINK,RIG.....	1
25	PAHZZ	5330011592811	7X677	14037958	RETAINER,PACKING.....	1
26	PAHZZ	5331004510118	34623	5740012	O-RING.....	1
27	PAHZZ	5305013594586	76760	16756	SCREW,CAP,HEXAGON H.....	1
28	PAHZZ	5331013589545	76760	15715	O-RING.....	1
29	PAHZZ	5360013586563	76760	17071	SPRING,HELICAL,COMP.....	1
30	PAHZZ	5340013588000	76760	16754	PLUNGER,DETENT.....	1
31	PAFZZ	5330013589532	73680	29960-0511	SEAL,PLAIN ENCASED FRONT OUTPUT,USE WITH T-CASE P/N 5937387..... UOC:AVY,A11,A13,A14,A15,A20,A24,A25, A26,A27,B16,B17,B18,HVY	1
31	PAFZZ	5330014133713	76760	19016	SEAL,PLAIN ENCASED FRONT OUTPUT,USE WITH T-CASE P/N 12342643-1 AND 12447125.....	1
32	PAOFF	2520011749554	34623	5938685	YOKE,UNIVERSAL JOIN FRONT.....	1
33	PAOZZ	2520011494993	34623	5740225	.DEFLECTOR,DIRT AND FRONT.....	1
34	XAOZZ		76760	13766	.YOKE,UNIVERSAL JOIN FRONT.....	1
35	PAOZZ	5310011482687	7X677	12338062	WASHER,LOCK.....	1
36	PAOZZ	5310011748091	82978	4167924	NUT,PLAIN,ASSEM.....	1
37	PAOZZ	5340012906234	76760	00015105	PLUG,LEAKPROOF SEAL.....	1
38	PAHZZ	2520011597757	7X677	3787240	MAGNET,CHIP COLLECT.....	1

END OF FIGURE

Section II.

TM 9-2320-280-24P-1

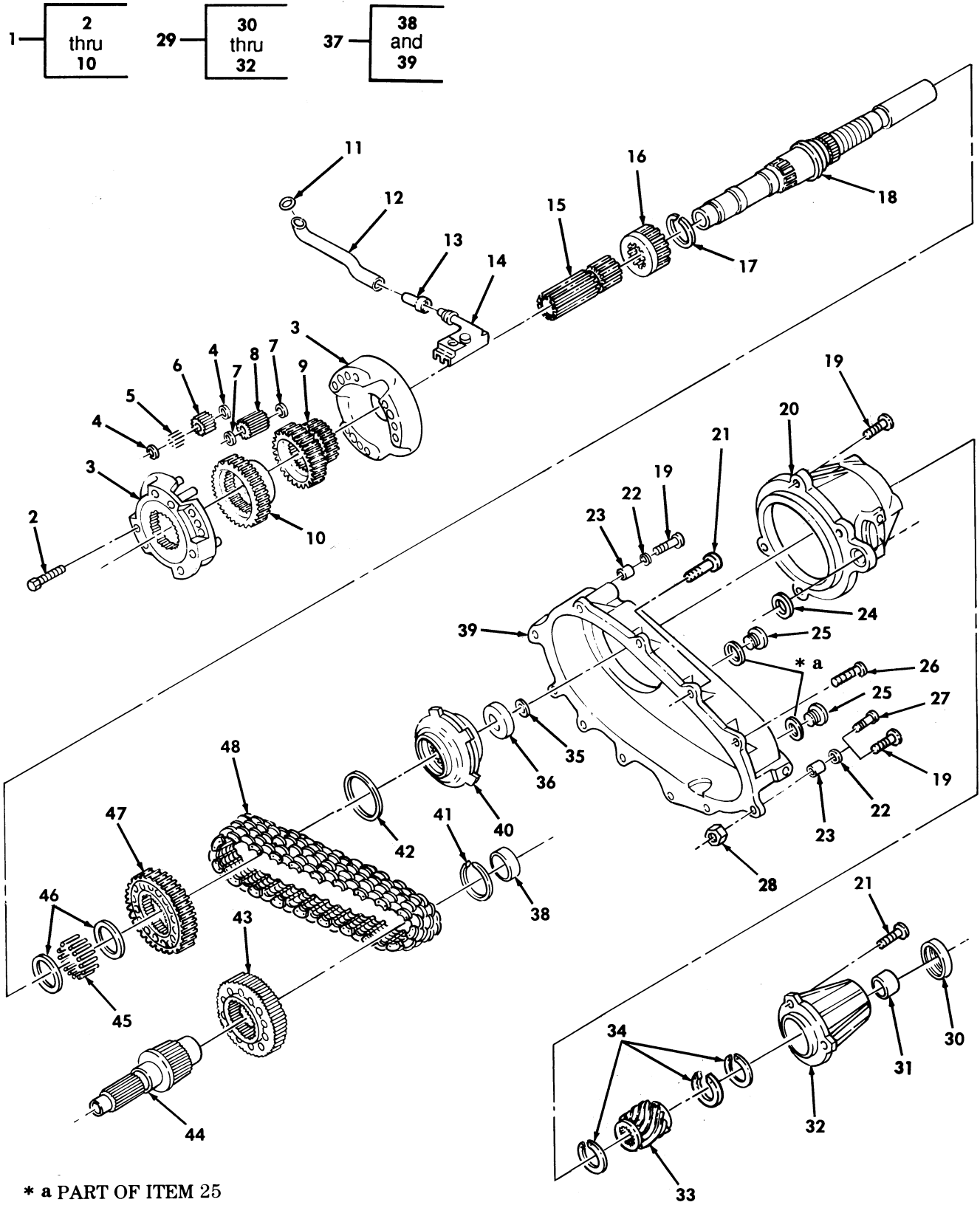

Figure 130. Transfer Case Assembly, P/N 5937387, 12342643-1, and 12447125 (Rear Half).

SECTION II			TM9-2320-280-24P			
(1)	(2)	(3)	(4)	(5)	(6)	(7)
ITEM	SMR			PART		
NO	CODE	NSN	CAGEC	NUMBER	DESCRIPTION AND USABLE ON CODES(UOC)	QTY
					GROUP 0801 POWER TRANSFER,FINAL DRIVE,PLANETARY OR DROP GEAR BOX ASSEMBLY	
					FIG. 130 TRANSFER CASE ASSEMBLY,P/N 5937387,12342643-1,AND 12447125 (REAR HALF)	
1	PAHHH	2520013588879	76760	17588	PLANETARY GEAR ASSE CARRIER.....	1
2	PAHZZ	5306013594530	76760	11797	.BOLT,MACHINE USE WITH T-CASE P/N 5937387.....	6
					UOC:AVY,A11,A13,A14,A15,A20,A24,A25, A26,A27,B16,B17,B18,HVY	
2	PAHZZ	5306013594530	76760	11797	.BOLT,MACHINE USE WITH T-CASE P/N 12342643-1 AND 12447125.....	3
3	PAHZZ	2520013588878	76760	16651	.PLANETARY GEAR ASSE.....	1
4	PAHZZ	5310013587974	76760	17568	.WASHER,FLAT.....	6
5	PAHZZ	3110013596669	76760	17567	.BEARING,ROLLER,NEED.....	54
6	PAHZZ	3020013591136	76760	17566	.GEAR,SPUR DIFFERENTIAL NARROW.....	3
7	PAHZZ	5310013587975	76760	16286	.WASHER,FLAT.....	6
8	PAHZZ	3020013588661	76760	16290	.GEAR,SPUR.....	3
9	PAHZZ	3020013588656	76760	17570	.GEAR CLUSTER.....	1
10	PAHZZ	2520013588658	76760	17573	.DIFFERENTIAL GEAR U.....	1
11	PAHZZ	5330013589541	76760	16214	SEAL,PLAIN TUBE"O"RING.....	1
12	PFHZZ	4710013588410	76760	17510	TUBE,BENT,METALLIC.....	1
13	PAHZZ	4720013586100	76760	16218	HOSE,NONMETALLIC.....	1
14	PAHZZ	4730013592217	34623	5938666	STRAINER ELEMENT,SE.....	1
15	PAHZZ	3020013588657	76760	16433	GEAR CLUSTER USE WITH T-CASE P/N 5937387.....	1
					UOC:AVY,A11,A13,A14,A15,A20,A24,A25, A26,A27,B16,B17,B18,HVY	
15	PAHZZ	3040014134022	76760	21065	SHAFT,STRAIGHT USE WITH T-CASE P/N 12342643-1 AND 12447125.....	1
16	PAHZZ	3020013588662	76760	17575	GEAR,SPUR.....	1
17	PAHZZ	5365013584641	76760	16297	SPACER,RING DIFFERENTIAL GEAR RETAINING.....	1
18	PAHZZ	3040013588692	76760	17565	GEARSHAFT,MULTIPLE USE WITH T-CASE P/N 5937387 AND 12342643-1.....	1
					UOC:AVY,A11,A13,A14,A15,A20,A24,A25, A26,A27,B16,B17,B18,HVY	
18	PAHZZ	3040014201887	76760	21909	SHAFT,SHOULDERED USE WITH T-CASE P/N 12447125.....	1
					UOC:BVY,B15,B20,B24,B25,C17,H11,H13, H14,H15,H16,H17,H18,H20,H21,H24,H25, H25,H26,H27,H28,MMM,NNN	
19	PAHZZ	5306011654283	24617	11500831	BOLT,SELF-LOCKING USE WITH T-CASE P/N 5937387 AND 12342643-1.....	6
					UOC:AVY,A11,A13,A14,A15,A20,A24,A25, A26,A27,B16,B17,B18,HVY	
19	PAHZZ	5306011654283	76760	61575	BOLT,SELF-LOCKING USE WITH T-CASE P/N 12447125.....	5
					UOC:BVY,B15,B20,B24,B25,C17,H11,H13, H14,H15,H16,H17,H18,H20,H21,H24,H25,	

SECTION II			TM9-2320-280-24P			
(1)	(2)	(3)	(4)	(5)	(6)	(7)
ITEM NO	SMR CODE	NSN	CAGEC	PART NUMBER	DESCRIPTION AND USABLE ON CODES(UC)	QTY
20	PAHZZ	3040013591119	76760	17584	H26,H27,H28,MMM,NNN HOUSING,MECHANICAL REAR BEARING USE WITH T-CASE P/N 5937387 AND 12342643-1..... UOC:AVY,A11,A13,A14,A15,A20,A24,A25,A26,A27,B16,B17,B18,HVY	1
20	PAHZZ	5330014159612	76760	21727	RETAINER,PACKING USE WITH T-CASE P/N 12447125..... UOC:BVY,B15,B20,B24,B25,C17,H11,H13,H14,H15,H16,H17,H18,H20,H21,H24,H25,H26,H27,H28,MMM,NNN	1
21	PAHZZ	5306011524696	24617	11503428	BOLT,SELF-LOCKING USE WITH T-CASE P/N 5937387 AND 12342643-1..... UOC:AVY,A11,A13,A14,A15,A20,A24,A25,A26,A27,B16,B17,B18,HVY	9
22	PAHZZ	5310011748158	34623	5740230	WASHER,FLAT DOWEL,CASE ALIGNMENT...	12
23	PAHZZ	5315011604642	7X677	14037948	PIN,SPRING CASE ALIGNMENT.....	2
24	PAHZZ	5315014640812	34623	5938665	PIN,STRAIGHT,HEADLE DOWEL.....	1
25	PAOZZ	5365014469408	76760	22398	PLUG,MACHINE THREAD.....	2
26	PAHZZ	5305012097668	34623	5741075	SCREW,SPECIAL.....	2
27	PAHZZ	5305014161269	76760	17844	SCREW,MACHINE USE WITH T-CASE P/N 12447125..... UOC:BVY,B15,B20,B24,B25,C17,H11,H13,H14,H15,H16,H17,H18,H20,H21,H24,H25,H26,H27,H28,MMM,NNN	1
28	PAHZZ	5310014163009	34623	5714233	NUT,PLAIN,HEXAGON USE WITH T-CASE P/N 12447125..... UOC:BVY,B15,B20,B24,B25,C17,H11,H13,H14,H15,H16,H17,H18,H20,H21,H24,H25,H26,H24,H28,MMM,NNN	1
29	PAHZH	3040013604448	76760	16221	HOUSING,MECHANICAL USE WITH T-CASE P/N 5937387 AND 12342643-1..... UOC:AVY,A11,A13,A14,A15,A20,A24,A25,A26,A27,B16,B17,B18,HVY	1
29	PAHHH	2520014131904	76760	19140	EXTENSION ASSEMBLY USE WITH T-CASE P/N 12447125..... UOC:BVY,B15,B20,B24,B25,C17,H11,H13,H14,H15,H16,H17,H18,H20,H21,H24,H25,H26,H24,H28,MMM,NNN	1
30	PAHZZ	5330013589540	76760	16104	.SEAL,PLAIN REAR OUTPUT USE WITH T-CASE P/N 5937387 AND 12342643-1... UOC:AVY,A11,A13,A14,A15,A20,A24,A25,A26,A27,B16,B17,B18,HVY	1
30	PAHZZ	5330014159613	76760	15896	.SEAL,PLAIN USE WITH T-CASE P/N 12447125..... UOC:BVY,B15,B20,B24,B25,C17,H11,H13,H14,H15,H16,H17,H18,H20,H21,H24,H25,H26,H24,H28,MMM,NNN	1
31	PAHZZ	5330013589533	76760	16081	.SEAL,PLAIN ENCASED USE WITH T-CASE P/N 5937387 AND 12347643-1..... UOC:AVY,A11,A13,A14,A15,A20,A24,A25,A26,A27,B16,B17,B18,HVY	1
31	PAHZZ	3120014178178	76760	17475	.BUSHING,SLEEVE USE WITH T-CASE P/N	1

SECTION II			TM9-2320-280-24P			
(1)	(2)	(3)	(4)	(5)	(6)	(7)
ITEM NO	SMR CODE	NSN	CAGEC	PART NUMBER	DESCRIPTION AND USABLE ON CODES(UC)	QTY
					12447125.....	
					UOC:BVY,B15,B20,B24,B25,C17,H11,H13,H14,H15,H16,H17,H18,H20,H21,H24,H25,H26,H27,H28,MMM,NNN	
32	XAHZZ		76760	16223	.EXTENSION USE WITH T-CASE P/N 5937387 AND 12342643-1.....	1
					UOC:AVY,A11,A13,A14,A15,A20,A24,A25,A26,A27,B16,B17,B18,HVY	
32	XAHZZ		76760	19134	.EXTENSION REAR HOUSING USE WITH T-CASE P/N 12447125.....	1
					UOC:BVY,B15,B20,B24,B25,C17,H11,H13,H14,H15,H16,H17,H18,H20,H21,H24,H25,H26,H27,H28,MMM,NNN	
33	PAHZZ	3020013588659	76760	16276	GEAR,HELICAL SPEEDO-DRIVE.....	1
34	PAHZZ	5325013587962	76760	13955	RING,RETAINING.....	3
35	PAHZZ	5330013591292	76760	15574	SEAL,PLAIN.....	1
36	PAHZZ	3120013600977	76760	15720	BEARING,WASHER,THRU USE WITH T-CASE P/N 5937387 AND 12342643-1.....	1
					UOC:AVY,A11,A13,A14,A15,A20,A24,A25,A26,A27,B16,B17,B18,HVY	
36	PAHZZ	3130013601051	34623	5938607	BEARING UNIT,PLAIN USE WITH T-CASE P/N 12447125.....	1
					UOC:BVY,B15,B20,B24,B25,C17,H11,H13,H14,H15,H16,H17,H18,H20,H21,H24,H25,H26,H27,H28,MMM,NNN	
37	PFHHZ	3040013591118	76760	17585	HOUSING,MECHANICAL.....	1
38	PAHZZ	3110011554440	60380	J-2416	.BEARING,ROLLER,NEED.....	1
39	XAHZZ		76760	17578	.CASE REAR HALF.....	1
40	PAHZZ	4320013588608	76760	16686	GEAR ROTOR SET,ROTA.....	1
41	PAHZZ	5325011576764	7X677	14037981	RING,RETAINING.....	1
42	PAHZZ	5325013587961	76760	13877	RING,RETAINING.....	1
43	PAHZZ	3020013592529	34623	5938663	SPROCKET WHEEL.....	1
44	PAHZZ	3040013588691	76760	16275	GEARSHAFT,SPUR FRONT OUTPUT.....	1
45	PAHZZ	3110013598858	34623	5938654	ROLLER SET,BEARING.....	53
46	PAHZZ	3120013605960	34623	5938653	BEARING,WASHER,THRU.....	2
47	PAHZZ	3020013592529	76760	17571	SPROCKET WHEEL.....	1
48	PAHZZ	3020013588601	76760	17577	CHAIN,SILENT.....	1

END OF FIGURE

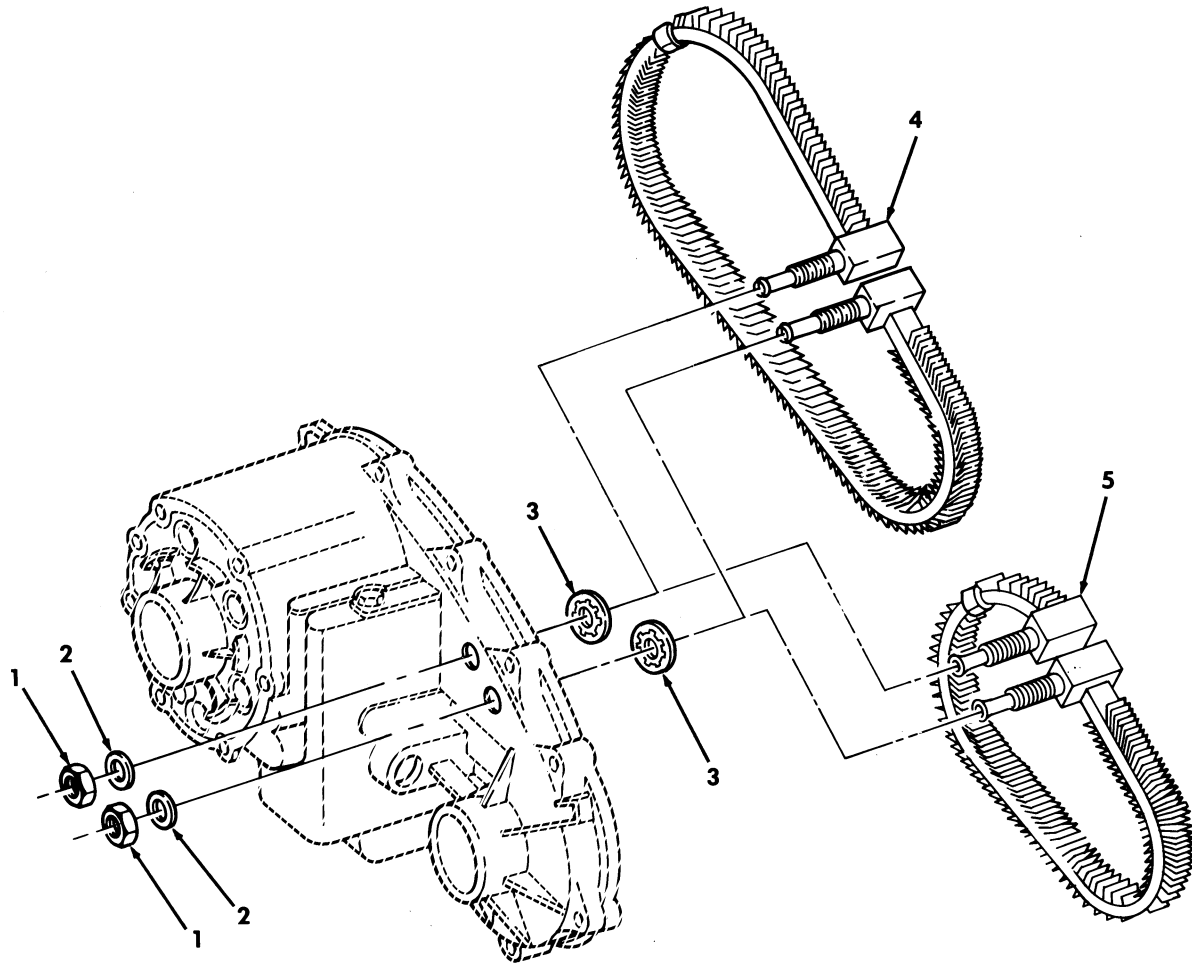

Figure 131. Transfer Oil Cooler Assembly.

SECTION II			TM9-2320-280-24P			
(1)	(2)	(3)	(4)	(5)	(6)	(7)
ITEM NO	SMR CODE	NSN	CAGEC	PART NUMBER	DESCRIPTION AND USABLE ON CODES(UOC)	QTY
					GROUP 0801 POWER TRANSFER, FINAL DRIVE, PLANETARY OR DROP GEAR BOX ASSEMBLY	
					FIG. 131 TRANSFER OIL COOLER ASSEMBLY	
1	PAHZZ	5310011354730	72582	9442899	NUT 1/2-20.....	2
2	PAHZZ	5310004719243	93334	6023054	WASHER, FLAT 1/2.....	2
3	PAHZZ	5331012097726	34623	5741062	O-RING.....	2
4	PAHZZ	2520012039871	34623	5741063	COOLER, CORE USE WITH P/N 12340073-1	1
					UOC:H11, H13, H14, H15, H16, H17, H18, H20, H21, H24, H25, H26, H27, H28, MMM	
5	PAHZZ	2520013587698	76760	17378	COOLER, FLUID, TRANSM USE WITH T-CASE P/N 5937387, 12447125, 12342643-1.....	1

END OF FIGURE



Section II.

TM 9-2320-280-24P-1

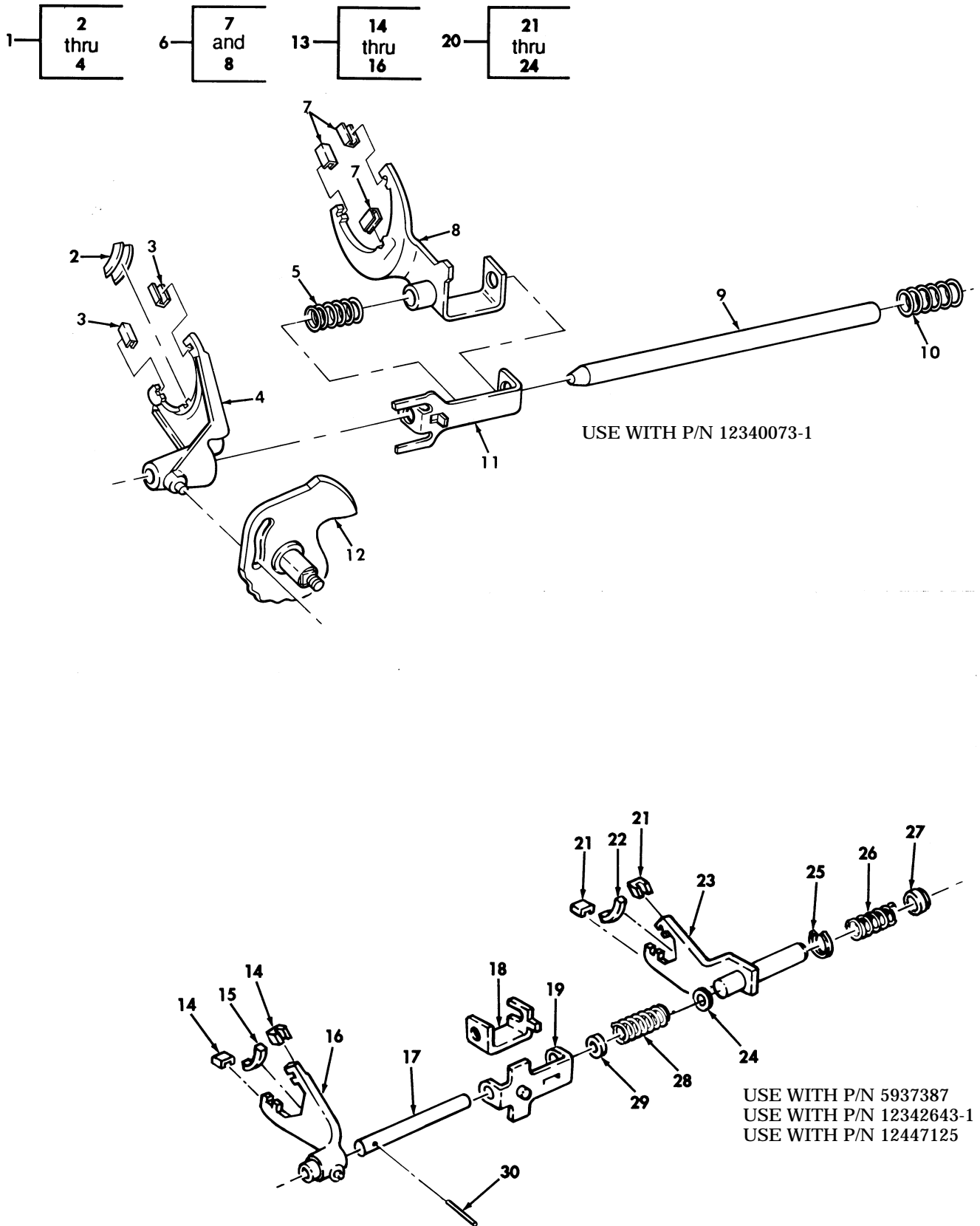

Figure 132. Transfer Shift Mechanisms.

SECTION II			TM9-2320-280-24P			
(1)	(2)	(3)	(4)	(5)	(6)	(7)
ITEM	SMR			PART		
NO	CODE	NSN	CAGEC	NUMBER	DESCRIPTION AND USABLE ON CODES(UOC)	QTY
GROUP 0801 TRANSFER ASSEMBLY						
FIG. 132 TRANSFER SHIFT MECHANISMS						
1	PAHHH	2520011756494	34623	5740227	SHIFTER FORK,VEHICU TRANSFER SHIFT. UOC:H11,H13,H14,H15,H16,H17,H18,H20, H21,H24,H25,H26,H27,H28,MMM	1
2	PAHZZ	2590011598757	34623	5740223	.PAD,FORK.....	1
3	PAHZZ	2520011628985	34623	5740114	UOC:H11,H13,H14,H15,H16,H17,H18,H20, H21,H24,H25,H26,H27,H28,MMM	2
4	XAHZZ		34623	5740226	.PAD,FORK,TRANSFER.....	1
5	PAHZZ	5360011748613	34623	5740115	UOC:H11,H13,H14,H15,H16,H17,H18,H20, H21,H24,H25,H26,H27,H28,MMM	1
6	PAHHH	2520012040325	34623	5741060	.SHIFTER FORK TRANSFER SHIFT.....	1
7	PAHZZ	2520011628985	34623	5740114	UOC:H11,H13,H14,H15,H16,H17,H18,H20, H21,H24,H25,H26,H27,H28,MMM	1
8	XAHZZ		34623	5740116	SPRING,HELICAL,COMP TRANSFER.....	1
9	PAHZZ	3040011762835	34623	5740220	UOC:H11,H13,H14,H15,H16,H17,H18,H20, H21,H24,H25,H26,H27,H28,MMM	1
10	PAHZZ	5360011748614	34623	5740126	SHIFTER FORK,VEHICU TRANSFER.....	1
11	PAHZZ	2520011745919	34623	5740125	UOC:H11,H13,H14,H15,H16,H17,H18,H20, H21,H24,H25,H26,H27,H28,MMM	1
12	PAHZZ	2520011762840	34623	5740221	.PAD,FORK,TRANSFER TRANSFER SHIFT.. UOC:H11,H13,H14,H15,H16,H17,H18,H20, H21,H24,H25,H26,H27,H28,MMM	3
13	PAHHH	2520013588701	76760	16472	.SHIFTER FORK FRONT MODE.....	1
14	PAHZZ	2520011628985	34623	5740114	UOC:H11,H13,H14,H15,H16,H17,H18,H20, H21,H24,H25,H26,H27,H28,MMM	1
15	PAHZZ	2590011598757	34623	5740223	SHAFT,STRAIGHT.....	1
16	XAHZZ		76760	16473	UOC:H11,H13,H14,H15,H16,H17,H18,H20, H21,H24,H25,H26,H27,H28,MMM	1
17	PFHZZ	3040013588596	76760	16449	SPRING,HELICAL,COMP MODE SHIFT	1
18	PAHZZ	2590013587643	76760	16310	TRANSFER.....	1
19	PAHZZ	2590013587644	76760	16474	UOC:H11,H13,H14,H15,H16,H17,H18,H20, H21,H24,H25,H26,H27,H28,MMM	1
20	PAHHH	2520013588700	76760	17586	BRACKET SUPPORT MODULATOR SHIFT....	1
21	PAHZZ	2520011628985	34623	5740114	UOC:H11,H13,H14,H15,H16,H17,H18,H20, H21,H24,H25,H26,H27,H28,MMM	1
22	PAHZZ	2520013588883	76760	15556	RANGE SECTOR AND SH SHAFT AND PIN..	1
23	XAHZZ		76760	17562	UOC:H11,H13,H14,H15,H16,H17,H18,H20, H21,H24,H25,H26,H27,H28,MMM	1
24	PAHZZ	5365013584642	76760	15624	.SHIFTER FORK.....	1
					.PAD,FORK,TRANSFER.....	2
					.PAD,FORK CENTER.....	1
					.FORK.....	1
					SHAFT,STRAIGHT.....	1
					BRACKET,VEHICULAR C.....	1
					BRACKET,VEHICULAR C.....	1
					SHIFTER FORK.....	1
					.PAD,FORK,TRANSFER.....	2
					.PAD,FORK,TRANSMISSI CENTER.....	1
					.FORK AND SLEEVE.....	1
					.SPACER,RING.....	2

SECTION II			TM9-2320-280-24P			
(1)	(2)	(3)	(4)	(5)	(6)	(7)
ITEM	SMR			PART		
NO	CODE	NSN	CAGEC	NUMBER	DESCRIPTION AND USABLE ON CODES(UOC)	QTY
25	PAHZZ	5310013587978	76760	16456	WASHER,SPRING TENSI.....	1
26	PAHZZ	5360013586564	34623	5938633	SPRING,HELICAL,COMP.....	1
27	PAHZZ	3120013596764	76760	16457	BUSHING,SLEEVE.....	1
28	PAHZZ	5360013585420	76760	17564	SPRING,HELICAL,COMP.....	1
29	PAHZZ	5340013587940	76760	16447	HOLDER,SPRING.....	1
30	PAHZZ	5315005760265	76760	91386	PIN,STRAIGHT,HEADLE.....	1

END OF FIGURE

**USE WITH BASIC AND A1 VEHICLES**

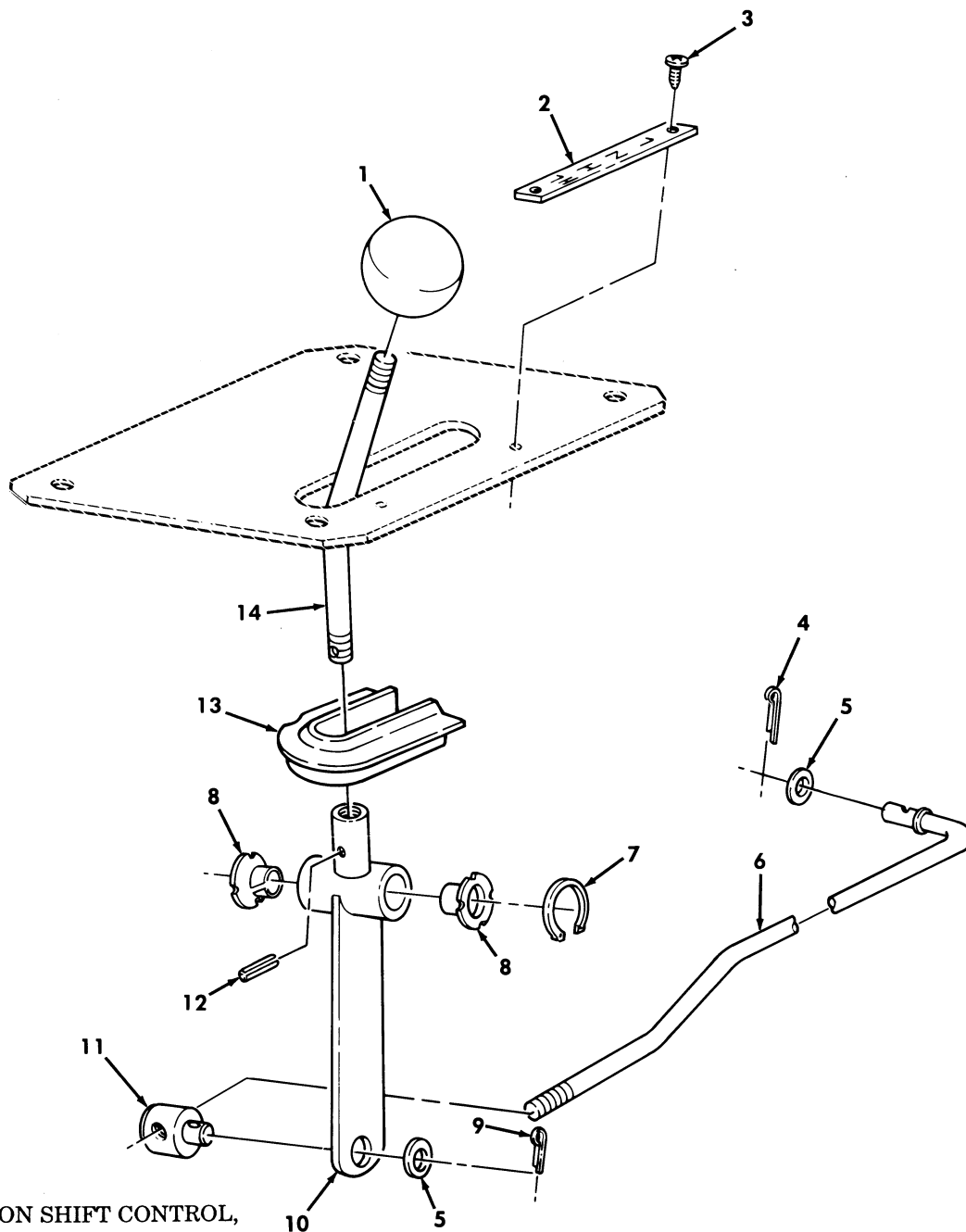

FOR TRANSMISSION SHIFT CONTROL,  
SEE FIGURE 99

*Figure 133. Transfer Shift Controls.*

SECTION II			TM9-2320-280-24P			
(1)	(2)	(3)	(4)	(5)	(6)	(7)
ITEM	SMR			PART		
NO	CODE	NSN	CAGEC	NUMBER	DESCRIPTION AND USABLE ON CODES(UC)	QTY
GROUP 0803 GEAR SHIFT,VACUUM BOOSTER AND CONTROLS						
FIG. 133 TRANSFER SHIFT CONTROLS						
1	PFOZZ	5355011962770	80813	230-7/16-14	KNOB..... UOC:AVY,A11,A13,A14,A15,A20,A24,A25,A26,A27,B16,B17,B18,HVY,H11,H13,H14,H15,H16,H17,H18,H20,H21,H24,H25,H26,H27,H28,MMM	1
2	PAOZZ	9905012076304	19207	12338433	PLATE,DESIGNATION..... UOC:AVY,A11,A13,A14,A15,A20,A24,A25,A26,A27,B16,B17,B18,HVY,H11,H13,H14,H15,H16,H17,H18,H20,H21,H24,H25,H26,H27,H28,MMM	1
3	PAOZZ	5305012506588	34623	5592952	SCREW,TAPPING,THREA #4-24 X 1/4.... UOC:AVY,A11,A13,A14,A15,A20,A24,A25,A26,A27,B16,B17,B18,HVY,H11,H13,H14,H15,H16,H17,H18,H20,H21,H24,H25,H26,H27,H28,MMM	2
4	PAOZZ	5315011912611	7X677	103384	PIN,COTTER 1/8 X 3/4..... UOC:AVY,A11,A13,A14,A15,A20,A24,A25,A26,A27,B16,B17,B18,HVY,H11,H13,H14,H15,H16,H17,H18,H20,H21,H24,H25,H26,H27,H28,MMM	1
5	PAOZZ	5310012057923	34623	5593213	WASHER,FLAT 3/8..... UOC:AVY,A11,A13,A14,A15,A20,A24,A25,A26,A27,B16,B17,B18,HVY,H11,H13,H14,H15,H16,H17,H18,H20,H21,H24,H25,H26,H27,H28,MMM	2
6	PAOZZ	5306012017969	19207	12338460	ROD,THREADED END..... UOC:AVY,A11,A13,A14,A15,A20,A24,A25,A26,A27,B16,B17,B18,HVY,H11,H13,H14,H15,H16,H17,H18,H20,H21,H24,H25,H26,H27,H28,MMM	1
7	PAOZZ	5325008037305	96906	MS16624-1062	RING,RETAINING..... UOC:AVY,A11,A13,A14,A15,A20,A24,A25,A26,A27,B16,B17,B18,HVY,H11,H13,H14,H15,H16,H17,H18,H20,H21,H24,H25,H26,H27,H28,MMM	1
8	PAOZZ	3120011913232	96881	10L18F	BEARING,SLEEVE..... UOC:AVY,A11,A13,A14,A15,A20,A24,A25,A26,A27,B16,B17,B18,HVY,H11,H13,H14,H15,H16,H17,H18,H20,H21,H24,H25,H26,H27,H28,MMM	2
9	PAOZZ	5315008423044	14351	X601	PIN,COTTER 3/32 X 3/4..... UOC:AVY,A11,A13,A14,A15,A20,A24,A25,A26,A27,B16,B17,B18,HVY,H11,H13,H14,H15,H16,H17,H18,H20,H21,H24,H25,H26,H27,H28,MMM	1
10	PFOZZ	2520011896726	19207	12338448	LEVER,REMOTE CONTRO..... UOC:AVY,A11,A13,A14,A15,A20,A24,A25,A26,A27,B16,B17,B18,HVY,H11,H13,H14,	1

SECTION II			TM9-2320-280-24P			
(1)	(2)	(3)	(4)	(5)	(6)	(7)
ITEM NO	SMR CODE	NSN	CAGEC	PART NUMBER	DESCRIPTION AND USABLE ON CODES(UOC)	QTY
11	PAOZZ	3040011854388	34623	5577813	H15,H16,H17,H18,H20,H21,H24,H25,H26, H27,H28,MMM HUB,BODY.....	1
					UOC:AVY,A11,A13,A14,A15,A20,A24,A25, A26,A27,B16,B17,B18,HVY,H11,H13,H14, H15,H16,H17,H18,H20,H21,H24,H25,H26, H27,H28,MMM	
12	PAOZZ	5315006164261	80205	MS16562-28	PIN,SPRING 3/32 X 3/4.....	1
					UOC:AVY,A11,A13,A14,A15,A20,A24,A25, A26,A27,B16,B17,B18,HVY,H11,H13,H14, H15,H16,H17,H18,H20,H21,H24,H25,H26, H27,H28,MMM	
13	PAOZZ	3120012510735	19207	12340565	BEARING,SLEEVE.....	1
					UOC:AVY,A11,A13,A14,A15,A20,A24,A25, A26,A27,B16,B17,B18,HVY,H11,H13,H14, H15,H16,H17,H18,H20,H21,H24,H25,H26, H27,H28,MMM	
14	PFOZZ	3040011892172	19207	12338459	LEVER,MANUAL CONTRO TRANSFER SHIFT.	1
					UOC:AVY,A11,A13,A14,A15,A20,A24,A25, A26,A27,B16,B17,B18,HVY,H11,H13,H14, H15,H16,H17,H18,H20,H21,H24,H25,H26, H27,H28,MMM	

END OF FIGURE

**USE WITH A2 VEHICLES**

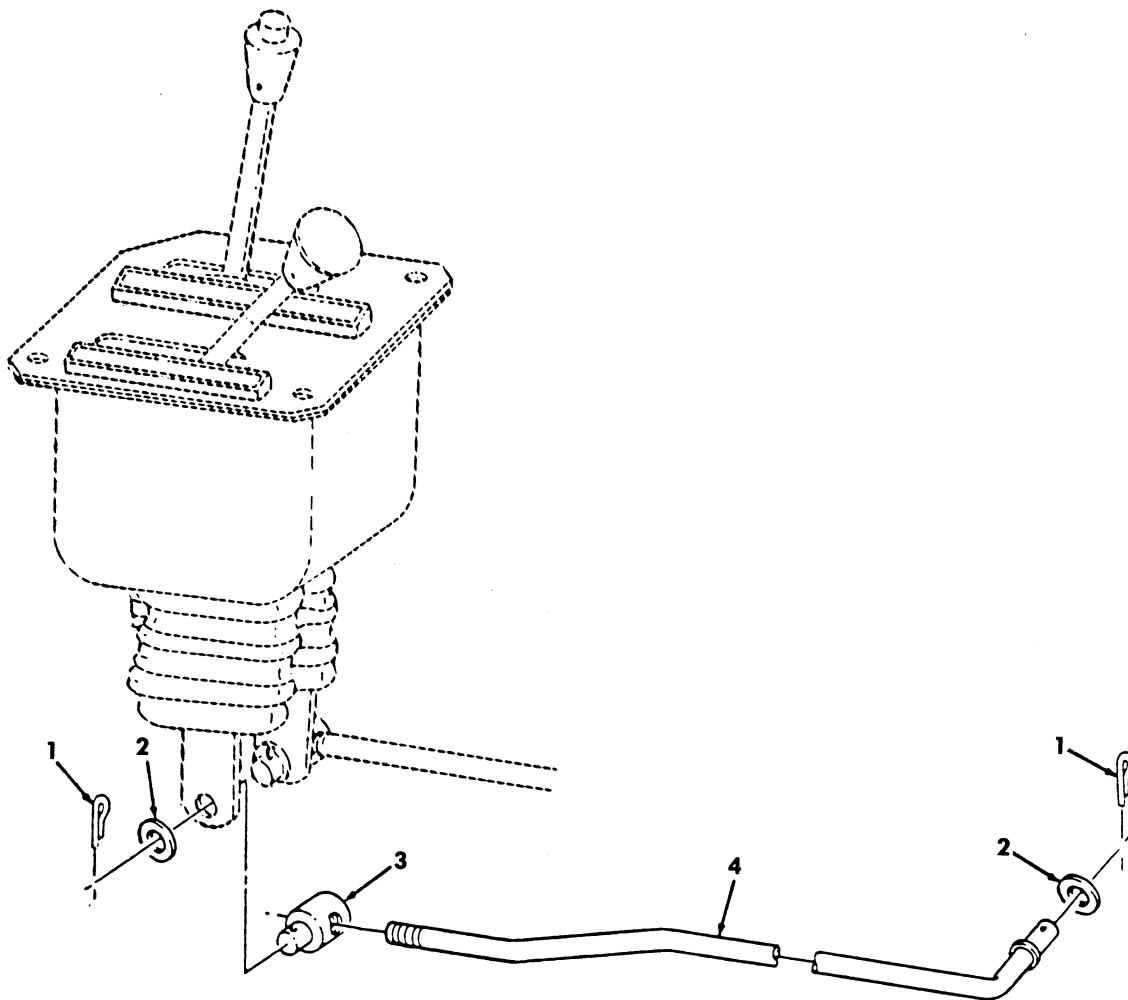

FOR TRANSMISSION SHIFT CONTROL,  
SEE FIGURE 98

*Figure 134. Transfer Shift Controls.*

SECTION II			TM9-2320-280-24P			
(1)	(2)	(3)	(4)	(5)	(6)	(7)
ITEM	SMR			PART		
NO	CODE	NSN	CAGEC	NUMBER	DESCRIPTION AND USABLE ON CODES(UC)	QTY
					GROUP 0803 GEAR SHIFT,VACUUM BOOSTER AND CONTROLS	
					FIG. 134 TRANSFER SHIFT CONTROLS	
1	PAOZZ	5315008395821	80205	MS24665-351	PIN,COTTER 1/8 X 3/4.....	2
					UOC:BVY,B15,B20,B24,B25,C17,NNN	
2	PAOZZ	5310000806004	96906	MS27183-14	WASHER,FLAT 3/8.....	2
					UOC:BVY,B15,B20,B24,B25,C17,NNN	
3	PAOZZ	2520014091602	34623	6001696	TRUNNION,POWER PLAN.....	1
					UOC:BVY,B15,B20,B24,B25,C17,NNN	
4	PAOZZ	3040014092501	34623	6003057	CONNECTING LINK,RIG.....	1
					UOC:BVY,B15,B20,B24,B25,C17,NNN	

END OF FIGURE



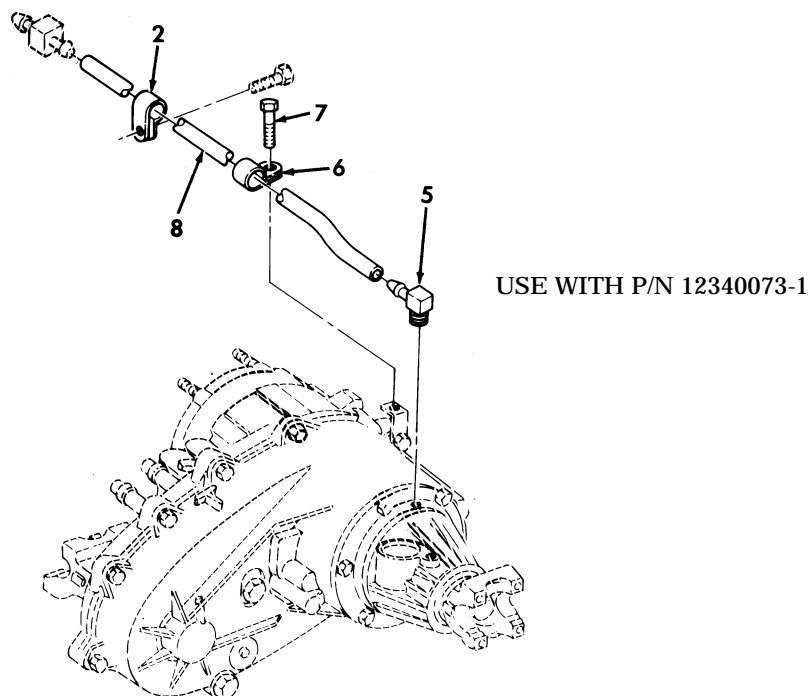
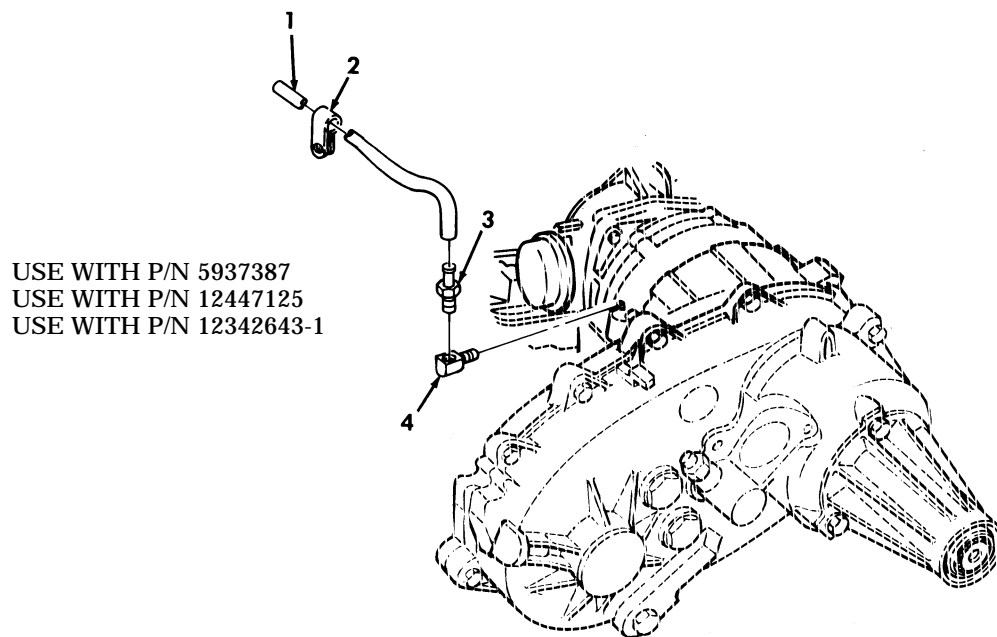

Figure 135. Transfer Case Vent Lines and Related Parts.

SECTION II			TM9-2320-280-24P			
(1)	(2)	(3)	(4)	(5)	(6)	(7)
ITEM NO	SMR CODE	NSN	CAGEC	PART NUMBER	DESCRIPTION AND USABLE ON CODES(UOC)	QTY
GROUP 0804 LUBRICATION, COOLING OR HYDRAULIC COMPONENTS AND SERVO UNITS						
FIG. 135 TRANSFER CASE VENT LINES AND RELATED PARTS						
1	MOZZ		19207	CPR104420-1-17	TUBING, NONMETALLIC MAKE FROM TUBE, P/N CPR104420-1, 17 INCHES LONG.....	1
2	PAZZ	5340000673868	96906	MS21333-109	CLAMP, LOOP.....	1
3	PAZZ	4730011855348	01989	1068X4	ADAPTER, STRAIGHT, PI TRANSFER CASE	1
4	PAZZ	4730012090845	81343	4-4 130239C(CAD)	ELBOW, PIPE.....	1
5	PAZZ	4730010707680	01989	1069X4	ELBOW, PIPE TO HOSE.....	1
UOC:H11, H13, H14, H15, H16, H17, H18, H20, H21, H24, H25, H26, H27, H28, MMM						
6	PAZZ	5340000509077	96906	MS21333-119	CLAMP, LOOP.....	1
UOC:H11, H13, H14, H15, H16, H17, H18, H20, H21, H24, H25, H26, H27, H28, MMM						
7	PAZZ	5305013936311	24617	271153	SCREW, TAPPING 3/8-16 X 1/2.....	1
UOC:H11, H13, H14, H15, H16, H17, H18, H20, H21, H24, H25, H26, H27, H28, MMM						
8	MOZZ		34623	5582645	TUBE MAKE FROM TUBE, P/N CPR104420-1, 24 INCHES LONG.....	1
UOC:H11, H13, H14, H15, H16, H17, H18, H20, H21, H24, H25, H26, H27, H28, MMM						

END OF FIGURE

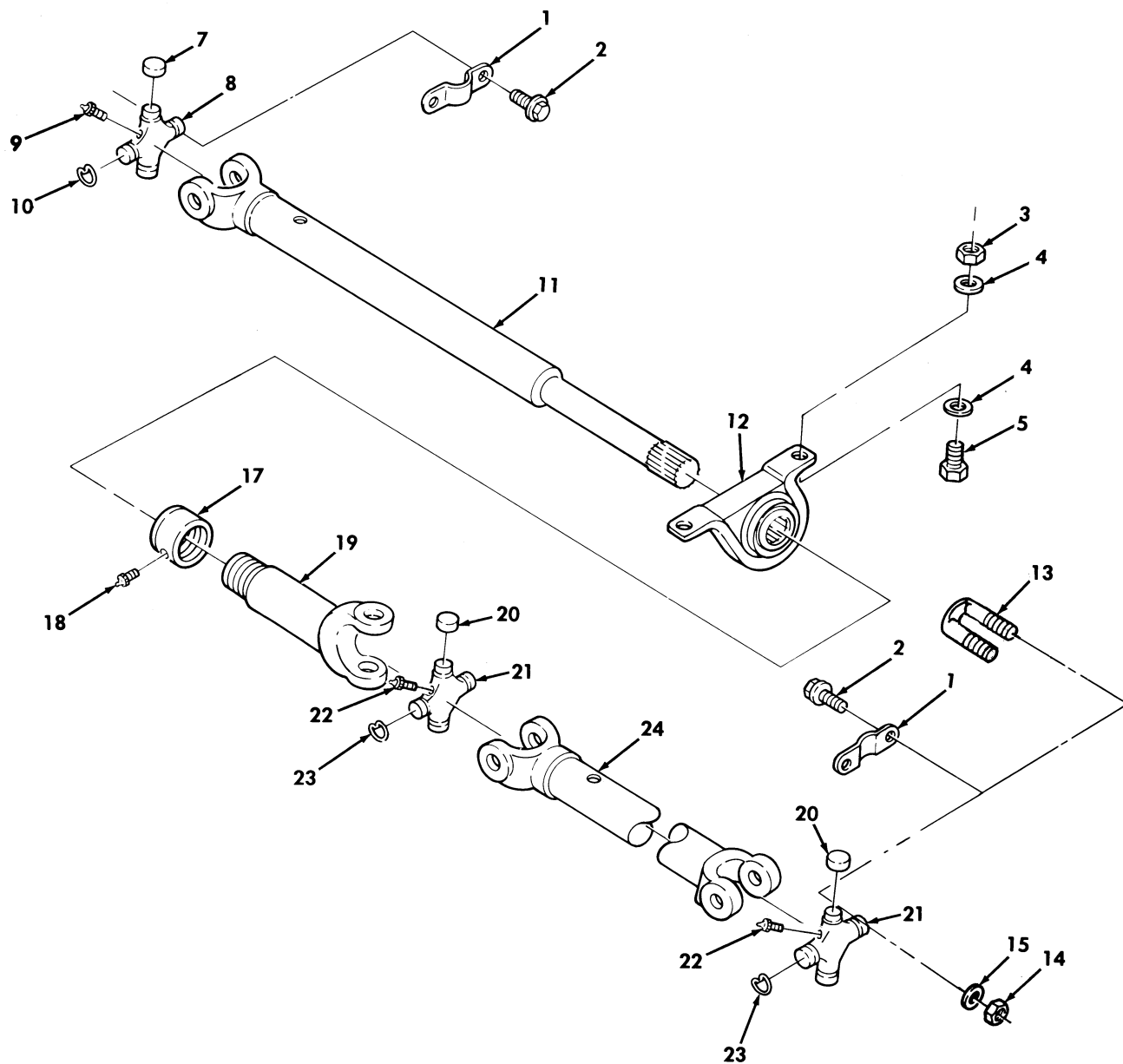
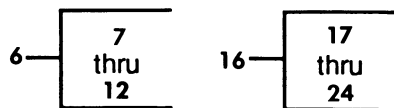

Figure 136. Front Propeller Shaft Assemblies.

SECTION II			TM9-2320-280-24P			
(1)	(2)	(3)	(4)	(5)	(6)	(7)
ITEM NO	SMR CODE	NSN	CAGEC	PART NUMBER	DESCRIPTION AND USABLE ON CODES(UOC)	QTY
					GROUP 09 PROPELLER SHAFTS 0900 PROPELLER SHAFTS	
					FIG. 136 FRONT PROPELLER SHAFT ASSEMBLIES	
1	PAOZZ	5340011900807	95019	2-70-59	STRAP,RETAINING USE WITH T-CASE P/N 12340073-1.....	4
					UOC:H11,H13,H14,H15,H16,H17,H18,H20,H21,H24,H25,H26,H27,H28,MMM	
1	PAOZZ	5340011900807	95019	2-70-59	STRAP,RETAINING USE WITH T-CASE P/N 5937387,12342643-1 AND 12447125.....	2
2	PAOZZ	5306011905760	95019	231401	BOLT,SELF-LOCKING 1/4 28 X .62,USE WITH T-CASE P/N 12340073-1,.....	8
					UOC:H11,H13,H14,H15,H16,H17,H18,H20,H21,H24,H25,H26,H27,H28,MMM	
2	PAOZZ	5306011905760	95019	231401	BOLT,SELF-LOCKING 1/4 28 X .62,USE WITH T-CASE P/N 5937387,12342643-1, AND 12447125.....	4
3	PAOZZ	5310011504003	24617	9422299	NUT,PLAIN,HEXAGON 7/16-14.....	2
4	PAOZZ	5310008094085	96906	MS27183-16	WASHER,FLAT CARRIER BEARING,7/16...	4
5	PAOZZ	5305000711786	80204	B1821BH044C100N	SCREW,CAP,HEXAGON H 7/16-14 X 1.00.	2
6	PAOFF	2520013569189	34623	12342620	PROPELLER SHAFT,VEH.....	1
					UOC:AVY,A11,A13,A14,A15,A20,A24,A25,A26,A27,B16,B17,B18,HVY	
6	PAOFF	2520012003097	95019	914202-1524	PROPELLER SHAFT.....	1
					UOC:H11,H13,H14,H15,H16,H17,H18,H20,H21,H24,H25,H26,H27,H28,MMM	
6	PAOFF	2520014235120	34623	6002629	PROPELLER SHAFT WIT.....	1
					UOC:BVY,B15,B20,B24,B25,C17,NNN	
7	KFOZZ		95019	2-6-1318X	.BEARING RACE PART OF KIT P/N 1-0153	4
					UOC:H11,H13,H14,H15,H16,H17,H18,H20,H21,H24,H25,H26,H27,H28,MMM	
7	KFOZZ		95019	2-6-288X	.BEARING RACE PART OF KIT P/N 5-213X	4
					UOC:AVY,A11,A13,A14,A15,A20,A24,A25,A26,A27,B16,B17,B18,BVY,B15,B20,B24,B25,C17,HVY,NNN	
8	KFOZZ		95019	2-5-668X	.CROSS ASSEMBLY PART OF KIT P/N 1-0153.....	1
					UOC:H11,H13,H14,H15,H16,H17,H18,H20,H21,H24,H25,H26,H27,H28,MMM	
8	KFOZZ		95019	2-5-848X	.CROSS ASSEMBLY PART OF KIT P/N 5-213X.....	1
					UOC:AVY,A11,A13,A14,A15,A20,A24,A25,A26,A27,B16,B17,B18,BVY,B15,B20,B24,B25,C17,HVY,NNN	
9	PAOZZ	4730000504203	13038	500174-1	.FITTING,LUBRICATION.....	1
10	PAOZZ	5325001749829	19207	5226154	.RING,RETAINING PART OF KIT P/N 5-213X PART OF KIT P/N 1-0153.....	4
11	XAOZZ		95019	2-60-996-1524	.PROPELLER SHAFT.....	1
					UOC:H11,H13,H14,H15,H16,H17,H18,H20,H21,H24,H25,H26,H27,H28,MMM	
11	XAOZZ		95019	2-60-1081	.PROPELLER SHAFT.....	1

SECTION II			TM9-2320-280-24P			
(1)	(2)	(3)	(4)	(5)	(6)	(7)
ITEM NO	SMR CODE	NSN	CAGEC	PART NUMBER	DESCRIPTION AND USABLE ON CODES(UOC)	QTY
					UOC:AVY,A11,A13,A14,A15,A20,A24,A25,A26,A27,B16,B17,B18,BVY,B15,B20,B24,B25,C17,HVY,NNN	
12	PAFZZ	3130012039870	95019	211415X	.BEARING UNIT,BALL.....	1
13	PAOZZ	5306014651564	19207	EC12339050	BOLT,U USE WITH T-CASE P/N 5937387,12342643-1,AND 12447125.....	2
14	PAOZZ	5310009054600	96906	MS51968-6	NUT,PLAIN,HEXAGON.....	4
15	PAOZZ	5310004079566	96906	MS35338-45	WASHER,LOCK.....	4
16	PAOOO	2520013575043	34623	5935394	PROPELLER SHAFT USE WITH T-CASE P/N 5937387,12342643-1,AND 12447125.....	1
					UOC:AVY,A11,A13,A14,A15,A20,A24,A25,A26,A27,B16,B17,B18,HVY,H11,H13,H14,H15,H16,H17,H18,H20,H21,H24,H25,H26,H27,H28,MMM	
16	PAOOO	2520012003096	95019	914201-2626	PROPELLER SHAFT USE WITH P/N 12340073-1.....	1
					UOC:H11,H13,H14,H15,H16,H17,H18,H20,H21,H24,H25,H26,H27,H28,MMM	
16	PAOOO	2520014130080	34623	6002607	PROPELLER SHAFT WIT.....	1
					UOC:BVY,B15,B20,B24,B25,C17,NNN	
17	PAOZZ	5340011881017	95019	211121X	.CAP,PROTECTIVE,DUST.....	1
18	PAOZZ	4730000504203	13038	500174-1	.FITTING,LUBRICATION.....	1
19	XAOZZ		95019	2-3-10021X	.YOKE,UNIVERSAL.....	1
					UOC:AVY,A11,A13,A14,A15,A20,A24,A25,A26,A27,B16,B17,B18,HVY,H11,H13,H14,H15,H16,H17,H18,H20,H21,H24,H25,H26,H27,H28,MMM	
19	XAOZZ		95019	2-3-11491KX	.YOKE,UNIVERSAL.....	1
					UOC:BVY,B15,B20,B24,B25,C17,NNN	
20	KFOZZ		95019	2-6-1318X	.BEARING RACE PART OF KIT P/N 1-0153	4
					UOC:H11,H13,H14,H15,H16,H17,H18,H20,H21,H24,H25,H26,H27,H28,MMM	
20	KFOZZ		95019	2-6-288X	.BEARING RACE PART OF KIT P/N 5-213X	4
21	KFOZZ		95019	2-5-668X	.CROSS ASSEMBLY PART OF KIT P/N 1-0153.....	1
					UOC:H11,H13,H14,H15,H16,H17,H18,H20,H21,H24,H25,H26,H27,H28,MMM	
21	KFOZZ		95019	2-5-848X	.CROSS ASSEMBLY PART OF KIT P/N 5-213X.....	1
					UOC:AVY,A11,A13,A14,A15,A20,A24,A25,A26,A27,B16,B17,B18,HVY,H11,H13,H14,H15,H16,H17,H18,H20,H21,H24,H25,H26,H27,H28,MMM	
22	PAOZZ	4730000504203	96906	MS15001-1	.FITTING,LUBRICATION.....	1
23	PAOZZ	5325001749829	19207	5226154	.RING,RETAINING PART OF KIT P/N 5-213X PART OF KIT P/N 1-0153.....	4
24	XAOZZ		95019	2-60-607	.PROPELLER SHAFT.....	1
					UOC:H11,H13,H14,H15,H16,H17,H18,H20,H21,H24,H25,H26,H27,H28,MMM	
24	XAOZZ		95019	2-60-1082	.PROPELLER SHAFT.....	1
					UOC:AVY,A11,A13,A14,A15,A20,A24,A25,A26,A27,B16,B17,B18,HVY,H11,H13,H14,H15,H16,H17,H18,H20,H21,H24,H25,H26,H27,H28,MMM	
24	XAOZZ		95019	2-60-1082A2	.PROPELLER SHAFT.....	1
					UOC:BVY,B15,B20,B24,B25,C17,NNN	

END OF FIGURE

Section II.

TM 9-2320-280-24P-1

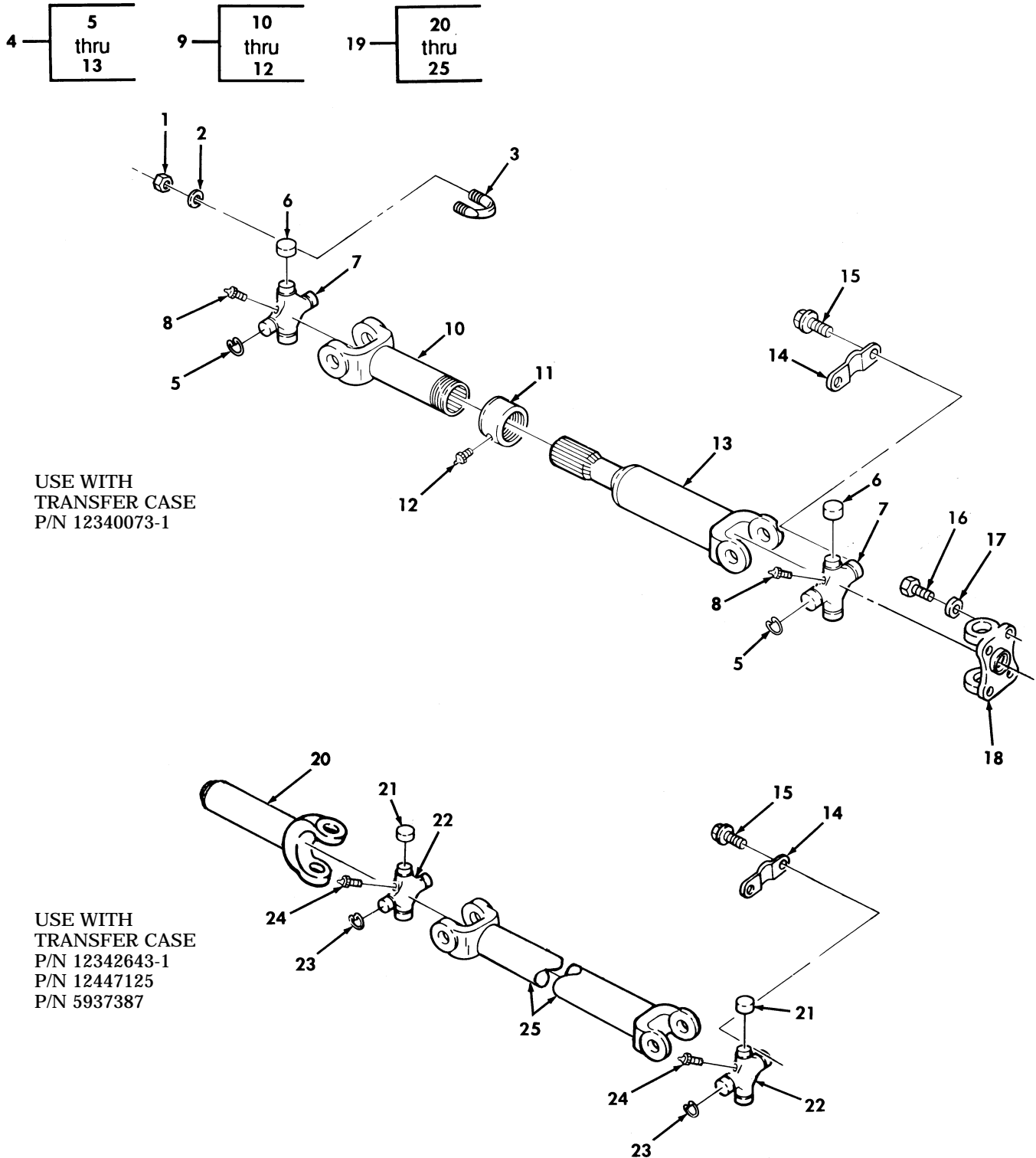

Figure 137. Rear Propeller Shaft Assemblies.

SECTION II			TM9-2320-280-24P			
(1)	(2)	(3)	(4)	(5)	(6)	(7)
ITEM NO	SMR CODE	NSN	CAGEC	PART NUMBER	DESCRIPTION AND USABLE ON CODES(UOC)	QTY
GROUP 0900 PROPELLER SHAFTS						
FIG. 137 REAR PROPELLER SHAFT ASSEMBLIES						
1	PAOZZ	5310008807746	96906	MS51968-5	NUT,PLAIN,HEXAGON 5/16-24..... UOC:H11,H13,H14,H15,H16,H17,H18,H20, H21,H24,H25,H26,H27,H28,MMM	4
2	PAOZZ	5310004079566	96906	MS35338-45	WASHER,LOCK 5/16..... UOC:H11,H13,H14,H15,H16,H17,H18,H20, H21,H24,H25,H26,H27,H28,MMM	4
3	PAOZZ	5306014651564	19207	EC12339050	BOLT,U 5/16-24..... UOC:H11,H13,H14,H15,H16,H17,H18,H20, H21,H24,H25,H26,H27,H28,MMM	2
4	PAOOO	2520011718258	95019	913359-1528	PROPELLER SHAFT USBL EFF 1 THRU 44824..... UOC:H11,H13,H14,H17,H18,H20,H24,H25, H26,H27,MMM	1
4	PAOOO	2520013461374	95019	915051-1624	PROPELLER SHAFT USBL EFF 44825 AND ABOVE..... UOC:H11,H13,H14,H15,H16,H17,H18,H20, H21,H24,H25,H26,H27,H28,MMM	1
5	PAOZZ	5325001749829	19207	5226154	.RING,RETAINING PART OF KIT P/N 5- 213X..... UOC:H11,H13,H14,H15,H16,H17,H18,H20, H21,H24,H25,H26,H27,H28,MMM	8
6	KFOZZ		95019	2-6-288X	.BEARING RACE PART OF KIT P/N 5-213X UOC:H11,H13,H14,H15,H16,H17,H18,H20, H21,H24,H25,H26,H27,H28,MMM	8
7	KFOZZ		95019	2-5-848X	.CROSS ASSEMBLY PART OF KIT P/N 5- 213X..... UOC:H11,H13,H14,H15,H16,H17,H18,H20, H21,H24,H25,H26,H27,H28,MMM	2
8	PAOZZ	4730000504203	96906	MS15001-1	.FITTING,LUBRICATION..... UOC:H11,H13,H14,H15,H16,H17,H18,H20, H21,H24,H25,H26,H27,H28,MMM	2
9	PFOZZ	2520011890594	95019	2-3-7961KX	.YOKE,UNIVERSAL JOIN..... UOC:H11,H13,H14,H15,H16,H17,H18,H20, H21,H24,H25,H26,H27,H28,MMM	1
10	XAOZZ		95019	2-3-7961X	..SLIP YOKE..... UOC:H11,H13,H14,H15,H16,H17,H18,H20, H21,H24,H25,H26,H27,H28,MMM	1
11	PAOZZ	5340011881017	95019	211121X	..CAP,PROTECTIVE,DUST..... UOC:H11,H13,H14,H15,H16,H17,H18,H20, H21,H24,H25,H26,H27,H28,MMM	1
12	PAOZZ	4730000504203	13038	500174-1	..FITTING,LUBRICATION..... UOC:H11,H13,H14,H15,H16,H17,H18,H20, H21,H24,H25,H26,H27,H28,MMM	1
13	XAOZZ		95019	2-60-899-1528	.PROPELLER SHAFT WIT USBL EFF 1 THRU 44824..... UOC:H11,H13,H14,H17,H18,H20,H24,H25, H26,H27,MMM	1
13	XAOZZ		95019	2-60-899-1623	.PROPELLER SHAFT USBL EFF 44825 AND	1

SECTION II			TM9-2320-280-24P			
(1)	(2)	(3)	(4)	(5)	(6)	(7)
ITEM NO	SMR CODE	NSN	CAGEC	PART NUMBER	DESCRIPTION AND USABLE ON CODES(UC)	QTY
					ABOVE.....	
					UC:H11,H13,H14,H15,H16,H17,H18,H20,H21,H24,H25,H26,H27,H28,MMM	
14	PAOZZ	5340011900807	95019	2-70-59	STRAP,RETAINING USBL EFF 44825 AND	2
					ABOVE.....	
15	PAOZZ	5306011905760	95019	231401	BOLT,SELF-LOCKING USBL EFF 44825	4
					AND ABOVE.....	
16	PAOZZ	5306011857052	7X677	9419293	BOLT,MACHINE USBL EFF 1 THRU 44824.	4
					UC:H11,H13,H14,H17,H18,H20,H24,H25,H26,H27,MMM	
17	PAOZZ	5310011854672	7X677	123153	WASHER,LOCK 7/16,USBL EFF 1 THRU	4
					44824.....	
					UC:H11,H13,H14,H17,H18,H20,H24,H25,H26,H27,MMM	
18	PFOZZ	2520012491506	95019	2-2-1209	YOKE,UNIVERSAL JOIN USBL EFF 1	1
					THRU 44824.....	
					UC:H11,H13,H14,H17,H18,H20,H24,H25,H26,H27,MMM	
19	PAOOO	2520013575044	34623	5937339	PROPELLER SHAFT USE WITH T-CASE P/N	1
					5937387 AND 12332643-1.....	
					UC:AVY,A11,A13,A14,A15,A20,A24,A25,A26,A27,B16,B17,B18,HVY	
19	PAOOO	2520014590050	34623	6007749	PROPELLER SHAFT WIT USE WITH T-CASE	1
					P/N 12447125 WHEN KIT P/N 57K3498 IS	
					INSTALLED.....	
					UC:H11,H13,H14,H15,H16,H17,H18,H20,H21,H24,H25,H26,H27,H28,MMM	
19	PAOOO	2520014132724	34623	6003666	PROPELLER SHAFT WIT.....	1
					UC:BVY,B15,B20,B24,B25,C17,NNN	
20	PAOZZ	2520013863384	95019	2-3-11781X	.YOKE,UNIVERSAL JOIN.....	1
					UC:AVY,A11,A13,A14,A15,A20,A24,A25,A26,A27,B16,B17,B18,HVY	
20	PAOZZ		95019	2-3-10831X	.YOKE,UNIVERSAL JOIN.....	1
					UC:BVY,B15,B20,B24,B25,C17,H11,H13,H14,H15,H16,H17,H18,H20,H21,H24,H25,H26,H27,H28,MMM,NNN	
21	KFOZZ		95019	2-6-288X	.BEARING RACE PART OF KIT P/N 5-213X	8
22	KFOZZ		95019	2-5-848X	.CROSS ASSEMBLY PART OF KIT P/N	2
					5-213X.....	
23	PAOZZ	5325001749829	19207	5226154	.RING,RETAINING PART OF KIT P/N	8
					5-213X.....	
24	PAOZZ	4730000504203	13038	500174-1	.FITTING,LUBRICATION.....	2
25	XAOZZ		95019	2-60-550	.SHAFT.....	1
					UC:AVY,A11,A13,A14,A15,A20,A24,A25,A26,A27,B16,B17,B18,HVY,H11,H13,H14,H15,H16,H17,H18,H20,H21,H24,H25,H26,H27,H28,MMM	
25	XAOZZ		95019	2-60-550A2	.SHAFT.....	1
					UC:BVY,B15,B20,B24,B25,C17,NNN	

END OF FIGURE



**USE WITH BASIC AND A1 VEHICLES**

1  
2  
thru  
15

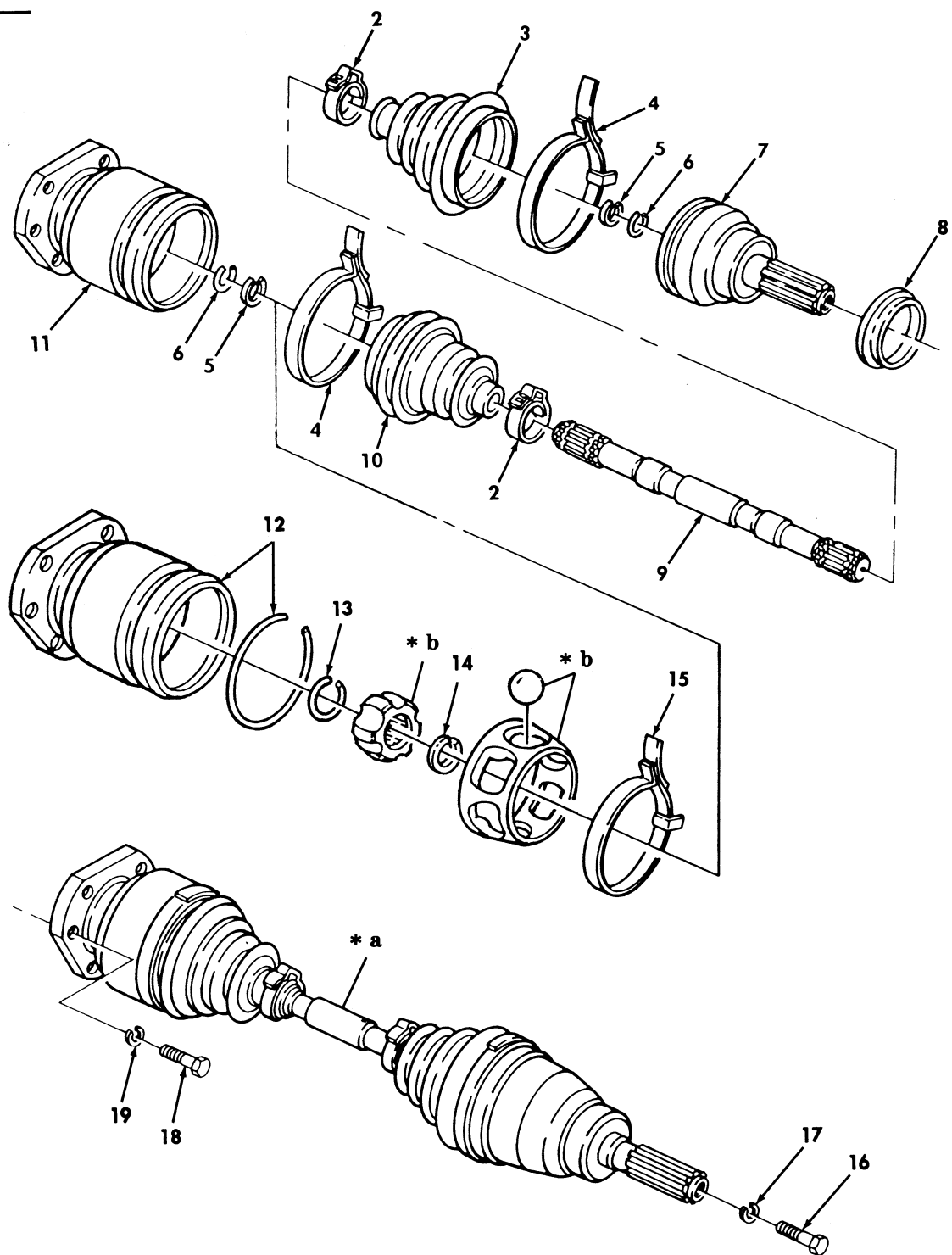

- \* a PART OF ITEM 1
- \* b PART OF ITEM 12

Figure 138. Front Halfshaft Assembly, Left and Right Side.

SECTION II			TM9-2320-280-24P			
(1)	(2)	(3)	(4)	(5)	(6)	(7)
ITEM NO	SMR CODE	NSN	CAGEC	PART NUMBER	DESCRIPTION AND USABLE ON CODES(UOC)	QTY
					GROUP 10 FRONT AXLE 1000 FRONT AXLE ASSEMBLY	
					FIG. 138 FRONT HALFSHAFT ASSEMBLY, LEFT AND RIGHT SIDE	
1	PAOOO	2520013828728	62826	2980301	PARTS KIT,CONSTANT FRONT,R.H..... UOC:AVY,A11,A13,A14,A15,A20,A24,A25, A26,A27,B16,B17,B18,HVY,H11,H13,H14, H15,H16,H17,H18,H20,H21,H24,H25,H26, H27,H28,MMM	1
1	PAOOO	2520013828874	62826	2980300	PARTS KIT,CONSTANT FRONT L.H..... UOC:AVY,A11,A13,A14,A15,A20,A24,A25, A26,A27,B16,B17,B18,HVY,H11,H13,H14, H15,H16,H17,H18,H20,H21,H24,H25,H26, H27,H28,MMM	1
2	KFOZZ		34623	5741547	.CLAMP,RACE USE WITH P/N'S 12341985-1,12341985-2,12341985-4, 12341985-5,PART OF KIT P/N 287-0006, PART OF KIT P/N 5705606..... UOC:H11,H13,H14,H15,H16,H17,H18,H20, H21,H24,H25,H26,H27,H28,MMM	2
2	PAOZZ	5340014241300	62826	1400164	.CLAMP,LOOP 33.7 MM PART OF KIT P/N 57K0274,PART OF KIT P/N 2880019.... UOC:AVY,A11,A13,A14,A15,A20,A24,A25, A26,A27,B16,B17,B18,HVY,H11,H13,H14, H15,H16,H17,H18,H20,H21,H24,H25,H26, H27,H28,MMM	2
3	KFOZZ		34623	5740258	.BOOT,FIXED USE WITH P/N'S 12341985-1,12341985-2,12341985-4, 12341985-5 PART OF KIT P/N 287-0006. UOC:H11,H13,H14,H15,H16,H17,H18,H20, H21,H24,H25,H26,H27,H28,MMM	1
3	KFOZZ		62826	2880015	.BOOT,FIXED PART OF KIT P/N 2880019. UOC:AVY,A11,A13,A14,A15,A20,A24,A25, A26,A27,B16,B17,B18,HVY,H11,H13,H14, H15,H16,H17,H18,H20,H21,H24,H25,H26, H27,H28,MMM	1
4	KFOZZ		34623	5741548	.CLAMP,RIM CLENCHING USE WITH P/N'S 12341985-1,12341985-2,12341985-4, 12341985-5,PART OF KIT P/N 5705606, PART OF KIT 287-0006..... UOC:H11,H13,H14,H15,H16,H17,H18,H20, H21,H24,H25,H26,H27,H28,MMM	2
4	PAOZZ	5340014211423	62826	1400165	.CLAMP,LOOP 99.8 MM PART OF KIT P/N 2880019..... UOC:AVY,A11,A13,A14,A15,A20,A24,A25, A26,A27,B16,B17,B18,HVY,H11,H13,H14, H15,H16,H17,H18,H20,H21,H24,H25,H26, H27,H28,MMM	1
5	PAOZZ	5365013831925	34623	5740549	.SPACER,RING USE WITH P/N'S 12341985-1,12341985-2,12341985-4, 12341985-5 PART OF KIT P/N 5741093	2

SECTION II			TM9-2320-280-24P			
(1)	(2)	(3)	(4)	(5)	(6)	(7)
ITEM NO	SMR CODE	NSN	CAGEC	PART NUMBER	DESCRIPTION AND USABLE ON CODES(UC)	QTY
6	PAOZZ	5325012122403	34623	5741098	PART OF KIT P/N 5741094..... UC:H11,H13,H14,H15,H16,H17,H18,H20, H21,H24,H25,H26,H27,H28,MMM .RING,RETAINING USE WITH P/N'S 12341985-1,12341985-2,12341985-4, 12341985-5 PART OF KIT P/N 5741093	2
7	PFOZZ	3040011891637	34623	5740551	PART OF KIT P/N 5741094..... UC:H11,H13,H14,H15,H16,H17,H18,H20, H21,H24,H25,H26,H27,H28,MMM .JOINT ASSEMBLY,DIFF USE WITH P/N'S 12341985-1,12341985-2,12341985-4, 12341985-5.....	1
8	PAOZZ	2530012969333	34623	5598209	UC:H11,H13,H14,H15,H16,H17,H18,H20, H21,H24,H25,H26,H27,H28,MMM .DEFLECTOR,DIRT AND.....	1
9	PFOZZ	3040011903574	34623	5740552	UC:AVY,A11,A13,A14,A15,A20,A24,A25, A26,A27,B16,B17,B18,HVY,H11,H13,H14, H15,H16,H17,H18,H20,H21,H24,H25,H26, H27,H28,MMM .SHAFT,SHOULDERED L.H.USE WITH P/N'S 12341985-1,PART OF KIT P/N 5741094..	1
9	KFOZZ		34623	5740255	UC:H11,H13,H14,H15,H16,H17,H18,H20, H21,H24,H25,H26,H27,H28,MMM .SHAFT,SHOULDERED R.H.USE WITH P/N'S 12341985-2,PART OF KIT P/N 5741093..	1
10	KFOZZ		34623	5740257	UC:H11,H13,H14,H15,H16,H17,H18,H20, H21,H24,H25,H26,H27,H28,MMM .BOOT,PLUNGE USE WITH P/N'S 12341985-1,12341985-2,12341985-4, 12341985-5 PART OF KIT P/N 5705606..	1
10	KFOZZ		62826	2880016	UC:H11,H13,H14,H15,H16,H17,H18,H20, H21,H24,H25,H26,H27,H28,MMM .BOOT,PLUNGE PART OF KIT P/N 57K0274.....	1
11	PFOZZ	2520011891636	34623	5740550	UC:AVY,A11,A13,A14,A15,A20,A24,A25, A26,A27,B16,B17,B18,HVY,H11,H13,H14, H15,H16,H17,H18,H20,H21,H24,H25,H26, H27,H28,MMM .JOINT ASSEMBLY,DIFF USE WITH P/N'S 12341985-1,12341985-2,12341985-4, 12341985-5.....	1
12	PFOZZ		62826	2180007	UC:H11,H13,H14,H15,H16,H17,H18,H20, H21,H24,H25,H26,H27,H28,MMM .JOINT ASSEMBLY USE WITH P/N 2980301 AND 2980300.....	1
13	KFOZZ		62826	2080021	UC:AVY,A11,A13,A14,A15,A20,A24,A25, A26,A27,B16,B17,B18,HVY,H11,H13,H14, H15,H16,H17,H18,H20,H21,H24,H25,H26, H27,H28,MMM .RING,RETAINER PART OF KIT P/N 57K0274,PART OF KIT P/N 2880019.....	2

SECTION II			TM9-2320-280-24P			
(1)	(2)	(3)	(4)	(5)	(6)	(7)
ITEM NO	SMR CODE	NSN	CAGEC	PART NUMBER	DESCRIPTION AND USABLE ON CODES(UC)	QTY
13	KFOZZ		62826	2080005	H15,H16,H17,H18,H20,H21,H24,H25,H26, H27,H28,MMM .RING,STOP PART OF KIT P/N 2880019 PART OF KIT P/N 57K0274,USE WITH P/N'S 12341985-4,12341985-5..... UC:HVY	2
14	KFOZZ		62826	2080007	.SPACER,RING PART OF KIT P/N 57K0274 PART OF KIT P/N 2880019..... UC:AVY,A11,A13,A14,A15,A20,A24,A25, A26,A27,B16,B17,B18,HVY,H11,H13,H14, H15,H16,H17,H18,H20,H21,H24,H25,H26, H27,H28,MMM	2
15	KFOZZ		62826	1400166	.CLAMP,LOOP 96.5 MM PART OF KIT P/N 57K0274,PART OF KIT P/N 2880019..... UC:AVY,A11,A13,A14,A15,A20,A24,A25, A26,A27,B16,B17,B18,HVY,H11,H13,H14, H15,H16,H17,H18,H20,H21,H24,H25,H26, H27,H28,MMM	1
16	PAOZZ	5305000680511	80204	B1821BH038C125N	SCREW,CAP,HEXAGON H 3/8-16 X 1.125.	2
17	PAOZZ	5310000115093	96906	MS35338-65	WASHER,LOCK 3/8.....	2
18	PAOZZ	5306011857048	7X677	11513606	BOLT,MACHINE 10-1.5 X 35 MM.....	12
19	PAOZZ	5310011857218	7X677	11500177	WASHER,LOCK 10MM.....	12

END OF FIGURE

**USE WITH A2 VEHICLES**

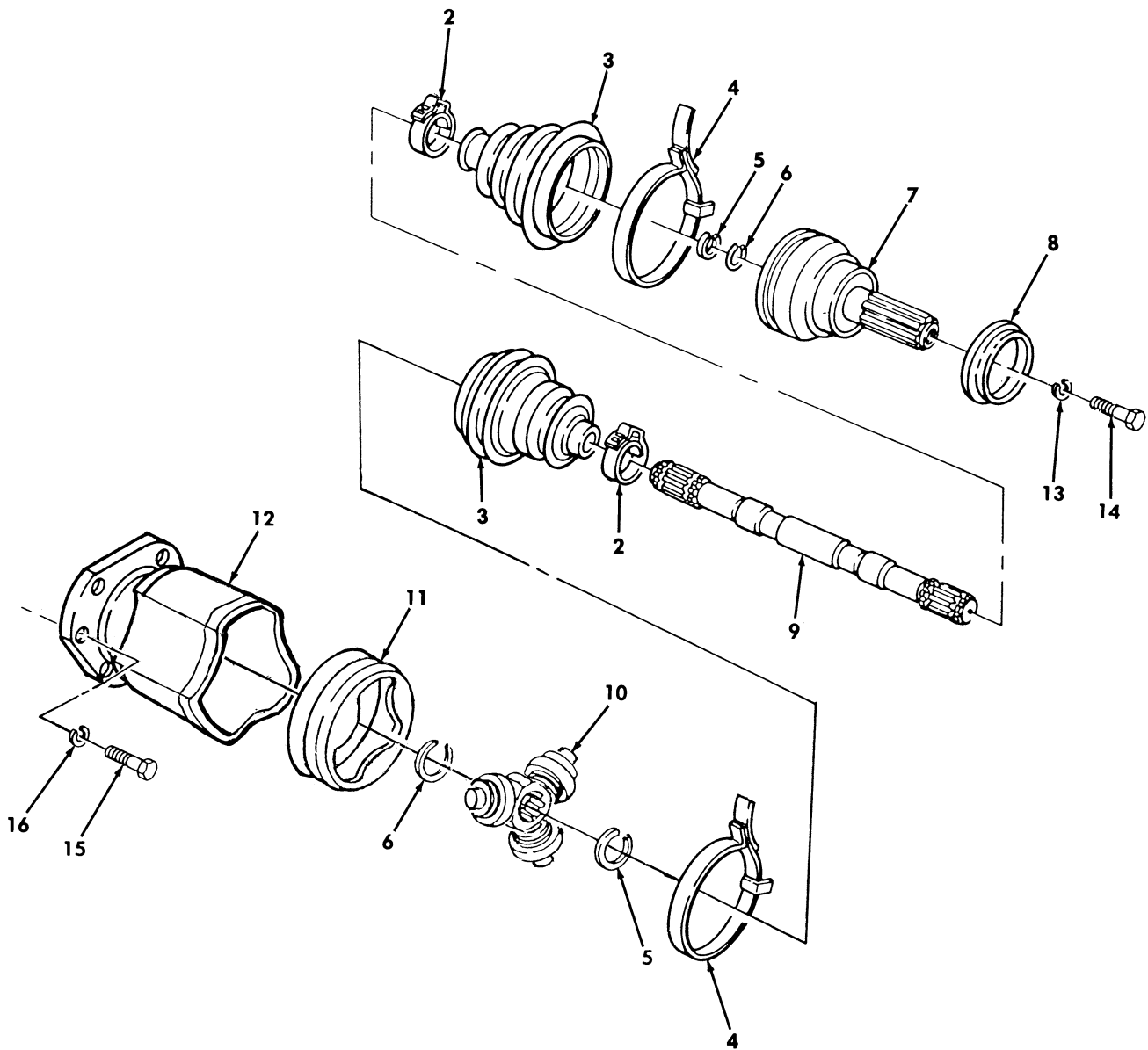
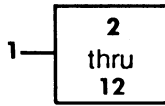
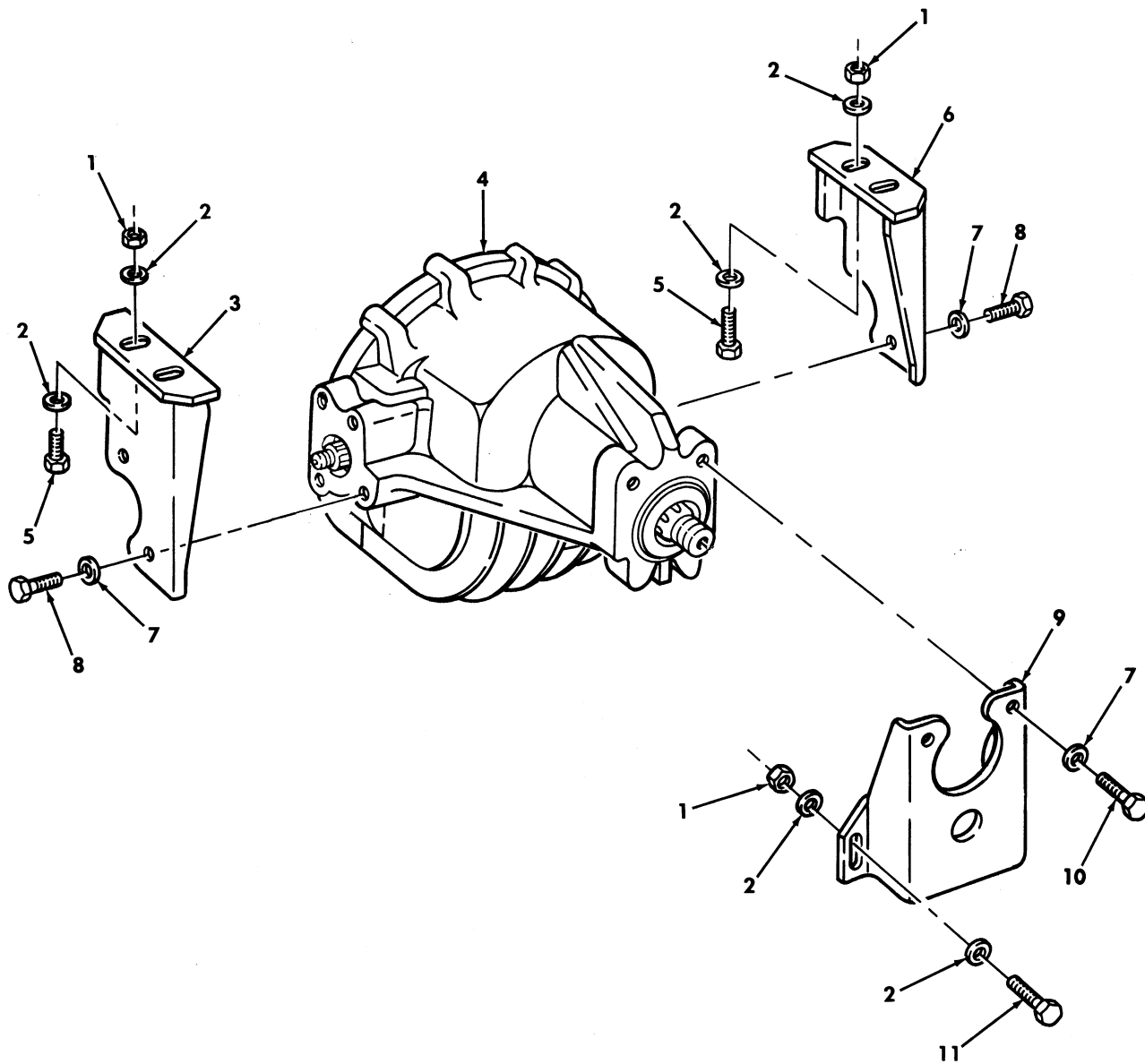

Figure 139. Front Halfshaft Assembly, Left and Right Side.

SECTION II			TM9-2320-280-24P			
(1)	(2)	(3)	(4)	(5)	(6)	(7)
ITEM NO	SMR CODE	NSN	CAGEC	PART NUMBER	DESCRIPTION AND USABLE ON CODES(UC)	QTY
GROUP 1000 FRONT AXLE ASSEMBLY						
FIG. 139 FRONT HALFSHAFT ASSEMBLY, LEFT AND RIGHT SIDE						
1	PAOOO	2520014231947	34623	RCSK17028-2	SHAFT,AXLE,AUTOMOTI FRONT,R.H..... UC:BVY,B15,B20,B24,B25,C17,NNN	1
1	PAOOO	2520014214588	34623	RCSK17028-3	SHAFT,AXLE,AUTOMOTI FRONT,L.H..... UC:BVY,B15,B20,B24,B25,C17,NNN	1
2	KFOZZ		62826	1400270	.CLAMP,BOOT 35.1MM PART OF KIT P/N 2990054,PART OF KIT P/N 2990055,PART OF KIT P/N 57K3515.....	2
3	KFOZZ		62826	2890019	.BOOT PART OF KIT P/N 2990054,PART OF KIT P/N 2990055,PART OF KIT P/N 57K3515.....	2
4	KFOZZ		62826	1400271	.CLAMP,BOOT 106.8MM PART OF KIT P/N 57K3515,PART OF KIT P/N 2990054,PART OF KIT P/N 2990055.....	2
5	KFOZZ		62826	2090004	.RING,SPACER PART OF KIT P/N 2390077 PART OF KIT P/N 2990054 PART OF KIT P/N 2390055 PART OF KIT P/N 57K3515. UC:BVY,B15,B20,B24,B25,C17,NNN	2
6	KFOZZ		62826	2090003	.RING,RETAINING PART OF KIT P/N 2390077,PART OF KIT P/N 2990054,PART OF KIT P/N 2990055,PART OF KIT P/N 57K3515.....	2
7	KFOZZ		62826	2290033	.JOINT ASSEMBLY FIXED PART OF KIT P/N 2990054,PART OF KIT P/N 2990055. UC:BVY,B15,B20,B24,B25,C17,NNN	1
8	PAOZZ	2530012969333	34623	5598209	.DEFLECTOR,DIRT AND PART OF KIT P/N 2990054,PART OF KIT P/N 2990055..... UC:BVY,B15,B20,B24,B25,C17,NNN	1
9	KFOZZ		62826	2790024	.SHAFT,SHOULDERED L.H. PART OF KIT P/N 2990054.....	1
9	KFOZZ		62826	2790026	.SHAFT,SHOULDERED R.H.,PART OF KIT P/N 2990055.....	1
10	KFOZZ		62826	2390036	.SPIDER ASSEMBLY PART OF KIT P/N 2390077.....	1
11	KFOZZ		62826	2390076	.INSERT PART OF KIT P/N 2390077..... UC:BVY,B15,B20,B24,B25,C17,NNN	1
12	KFOZZ		62826	2390074	.JOINT,PLUNGE PART OF KIT P/N 2390077.....	1
13	PAOZZ	5310000115093	96906	MS35338-65	WASHER,LOCK..... UC:BVY,B15,B20,B24,B25,C17,NNN	2
14	PAOZZ	5305000680511	80204	B1821BH038C125N	SCREW,CAP,HEXAGON H.....	2

SECTION II			TM9-2320-280-24P			
(1)	(2)	(3)	(4)	(5)	(6)	(7)
ITEM	SMR			PART		
NO	CODE	NSN	CAGEC	NUMBER	DESCRIPTION AND USABLE ON CODES(UC)	QTY
15	PAOZZ	5306011857048	7X677	11513606	UOC:BVY,B15,B20,B24,B25,C17,NNN BOLT,MACHINE 10-1.5 X 35MM.....	12
16	PAOZZ	5310011857218	7X677	11500177	UOC:BVY,B15,B20,B24,B25,C17,NNN WASHER,LOCK 10MM.....	12

END OF FIGURE



FOR BREAKDOWN PARTS OF  
ITEM 4, SEE FIGURE 148

Figure 140. Front Axle Differential, Mounting Bracket, and Hardware.



SECTION II		TM9-2320-280-24P				
(1)	(2)	(3)	(4)	(5)	(6)	(7)
ITEM NO	SMR CODE	NSN	CAGEC	PART NUMBER	DESCRIPTION AND USABLE ON CODES(UOC)	QTY
GROUP 1002 DIFFERENTIAL						
FIG. 140 FRONT AXLE DIFFERENTIAL, MOUNTING BRACKET, AND HARDWARE						
1	PAFZZ	5310004883889	96906	MS51943-39	NUT, SELF-LOCKING, HE 1/2-13.....	8
2	PAFZZ	5310008898782	34623	5593416	WASHER, FLAT 1/2.....	16
3	PAFZZ	5340012546543	19207	12338150-1	BRACKET, MOUNTING L.H.....	1
4	PAFHH	2520012912975	19207	12338415-3	DIFFERENTIAL, DRIVIN.....	1
					UOC:H11, H13, H14, H15, H16, H17, H18, H20, H21, H24, H25, H26, H27, H28, MMM	
4	PAFHH	2520013583160	34623	5597777	AXLE ASSEMBLY, AUTOM.....	1
					UOC:AVY, A11, A13, A14, A15, A20, A24, A25, A26, A27, BVY, B15, B16, B17, B18, B20, B24, B25, C17, HVY, NNN	
5	PAFZZ	5305000712066	80204	B1821BH050C100N	SCREW, CAP, HEXAGON H 1/2-13 X 1.00..	6
6	PFFZZ	2530012573864	19207	12338150-2	BRACKET, HANGER AXLE R.H.....	1
7	PAFZZ	5310011517347	24617	2436167	WASHER, FLAT 5/8.....	6
8	PAFZZ	5305007247219	80204	B1821BH063C125N	SCREW, CAP, HEXAGON H 5/8-11 X 1.25..	4
9	PAFZZ	5340013811808	19207	12342801	BRACKET, MOUNTING.....	1
					UOC:AVY, A11, A13, A14, A15, A20, A24, A25, A26, A27, B16, B17, B18, HVY	
9	PAFZZ	5340011757208	19207	12338215	BRACKET, MOUNTING.....	1
					UOC:H11, H13, H14, H15, H16, H17, H18, H20, H21, H24, H25, H26, H27, H28, MMM	
9	PAFZZ	5340014328680	34623	6002219	BRACKET, MOUNTING.....	1
					UOC:BVY, B15, B20, B24, B25, C17, NNN	
10	PAFZZ	5305007247220	80204	B1821BH063C150N	SCREW, CAP, HEXAGON H 5/8-11 X 1-1/2.	2
11	PAFZZ	5305000712066	80204	B1821BH050C100N	SCREW, CAP, HEXAGON H 1/2-13 X 1.00..	2
					UOC:AVY, A11, A13, A14, A15, A20, A24, A25, A26, A27, B16, B17, B18, HVY, H11, H13, H14, H15, H16, H17, H18, H20, H21, H24, H25, H26, H27, H28, MMM	
11	PAFZZ	5305000712067	80204	B1821BH050C125N	SCREW, CAP, HEXAGON H 1/2-13 X 1.25..	2
					UOC:BVY, B15, B20, B24, B25, C17, NNN	

END OF FIGURE

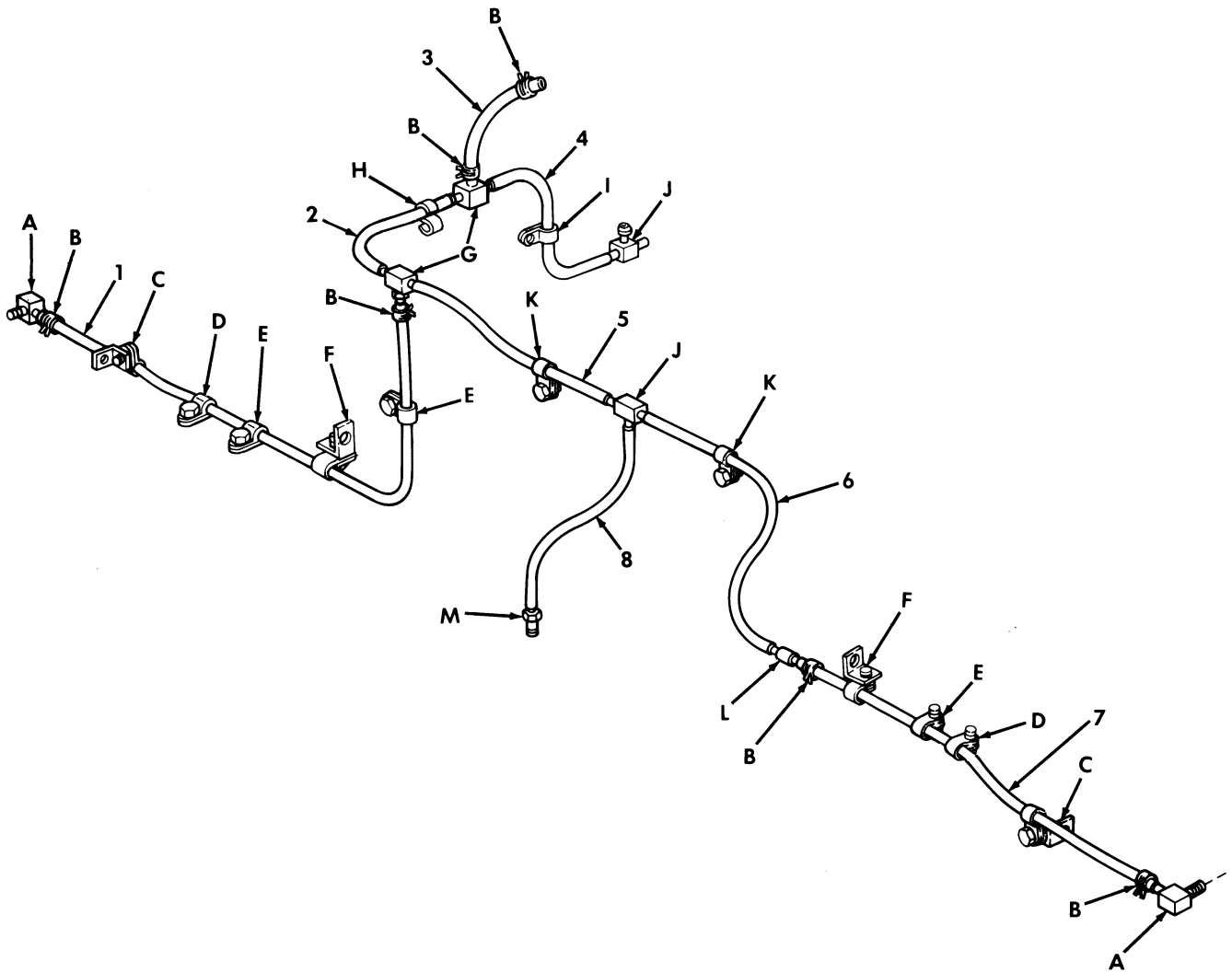





 <p><b>VIEW A</b></p>	 <p><b>VIEW B</b></p>	 <p><b>VIEW C</b></p>	 <p><b>VIEW D</b></p>	 <p><b>VIEW E</b></p>	 <p><b>VIEW F</b></p>	 <p><b>VIEW G</b></p>
 <p><b>VIEW H</b></p>	 <p><b>VIEW I</b></p>	 <p><b>VIEW J</b></p>	 <p><b>VIEW K</b></p>	 <p><b>VIEW L</b></p>	 <p><b>VIEW M</b></p>	

Figure 141. Front Axle Differential and Geared Hub Vent Lines.

SECTION II			TM9-2320-280-24P			
(1)	(2)	(3)	(4)	(5)	(6)	(7)
ITEM NO	SMR CODE	NSN	CAGEC	PART NUMBER	DESCRIPTION AND USABLE ON CODES(UC)	QTY
GROUP 1002 DIFFERENTIAL						
FIG. 141 FRONT AXLE DIFFERENTIAL AND GEARED HUB VENT LINES						
1	MOOZZ		19207	12339981-9	HOSE, NONMETALLIC R.H. MAKE FROM HOSE, P/N RB1450-1-4IDX1-20D, 34 INCHES LONG.....	1
					UC:AVY,A11,A13,A14,A15,A20,A24,A25,A26,A27,BVY,B15,B16,B17,B18,B20,B24,B25,C17,NNN	
1	MOOZZ		34623	5584383	HOSE R.H., MAKE FROM HOSE, P/N RB1450-1-4IDX1-20D, 32 INCHES LONG...	1
					UC:HVY,H11,H13,H14,H15,H16,H17,H18,H20,H21,H24,H25,H26,H27,H28,MMM	
2	MOOZZ		34623	5582643	TUBE MAKE FROM TUBING, P/N CPR104420-1, 15 INCHES LONG.....	1
3	MOOZZ		34623	5584372	HOSE MAKE FROM HOSE, P/N RB1450-1-4IDX1-20D, 8 INCHES LONG.....	1
4	MOOZZ		19207	CPR104420-1-4	TUBE MAKE FROM TUBING, P/N CPR104420-1, 4 INCHES LONG.....	1
5	MOOZZ		34623	5591483	TUBE MAKE FROM TUBING, P/N CPR104420-1, 14 INCHES LONG.....	1
6	MOOZZ		34623	5591482	TUBE MAKE FROM TUBING, P/N CPR104420-1, 12 INCHES LONG.....	1
7	MOOZZ		34623	5582649	HOSE, NONMETALLIC L.H., MAKE FROM HOSE, P/N RB1450-1-4IDX1-20D, 25 INCHES LONG.....	1
					UC:HVY,H11,H13,H14,H15,H16,H17,H18,H20,H21,H24,H25,H26,H27,H28,MMM	
7	MOOZZ		19207	12339981-8	HOSE L.H., MAKE FROM HOSE P/N RB1450-1-4IDX1-20D, 28 IN LONG.....	1
					UC:AVY,A11,A13,A14,A15,A20,A24,A25,A26,A27,BVY,B15,B16,B17,B18,B20,B24,B25,C17,NNN	
8	MOOZZ		34623	5584173	TUBE MAKE FROM TUBING, P/N CPR104420-1, 8 INCHES LONG.....	1
9	PAOZZ	4730012004277	79470	1582	ELBOW, PIPE TO HOSE.....	2
10	PAOZZ	4730009541251	59199	UM5008	CLAMP, HOSE.....	6
11	PAOZZ	5305000518605	80205	MS16995-77	SCREW, CAP, SOCKET HE 3/8-16 X 1/2...	9
12	PAOZZ	5340012159170	08627	C3263	CLAMP, LOOP.....	7
13	PFOZZ	5340013003715	34623	5598208	BRACKET, ANGLE.....	2
14	PAOZZ	5305000680502	96906	MS90725-6	SCREW, CAP, HEXAGON H.....	1
					UC:AVY,A11,A13,A14,A15,A20,A24,A25,A26,A27,BVY,B15,B16,B17,B18,B20,B24,B25,C17,NNN	
15	PAOZZ	5310008094058	96906	MS27183-10	WASHER, FLAT 1/4.....	2
					UC:AVY,A11,A13,A14,A15,A20,A24,A25,A26,A27,BVY,B15,B16,B17,B18,B20,B24,B25,C17,NNN	
16	PAOZZ	5340014605306	19207	12340571-2	CLAMP, LOOP.....	2
					UC:AVY,A11,A13,A14,A15,A20,A24,A25,A26,A27,BVY,B15,B16,B17,B18,B20,B24,	

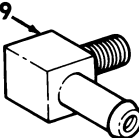
SECTION II			TM9-2320-280-24P			
(1)	(2)	(3)	(4)	(5)	(6)	(7)
ITEM	SMR			PART		
NO	CODE	NSN	CAGEC	NUMBER	DESCRIPTION AND USABLE ON CODES(UC)	QTY
17	PAOZZ	5310000614650	96906	MS51943-31	B25,C17,NNN NUT,SELF-LOCKING,HE.....	2
					UC:AVY,A11,A13,A14,A15,A20,A24,A25, A26,A27,BVY,B15,B16,B17,B18,B20,B24, B25,C17,NNN	
18	PFOZZ	5340011902248	19207	12338170	BRACKET,ANGLE.....	2
19	PAOZZ	4730011928086	01989	1077X4	TEE,PIPE TO HOSE.....	2
20	PAOZZ	4730010048346	79470	1537	ADAPTER,STRAIGHT,PI.....	2
21	PAOZZ	5340011870892	19207	12339890	CLIP,SPRING TENSION.....	1
					UC:HVY,H11,H13,H14,H15,H16,H17,H18, H20,H21,H24,H25,H26,H27,H28,MMM	
22	PAOZZ	5340000673868	96906	MS21333-109	CLAMP,LOOP FRONT.....	1
23	PAOZZ	4730010035105	79470	1064X4	TEE,HOSE FRONT.....	2
24	PAOZZ	5340000509077	08627	406CD	CLAMP,LOOP.....	2
25	PAOZZ	4730011844760	01989	1062X6X4	REDUCER,HOSE FRONT.....	1
26	PAOZZ	4730011855348	01989	1068X4	ADAPTER,STRAIGHT,PI FRONT.....	1

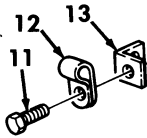
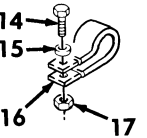
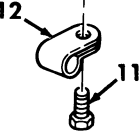
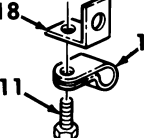
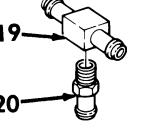
END OF FIGURE

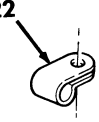
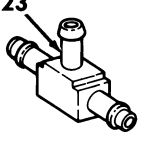
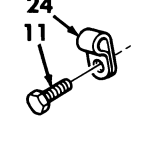
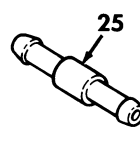
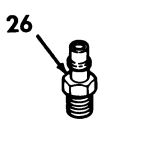
USE WITH BASIC AND A1 VEHICLES

1 — 2  
thru  
33

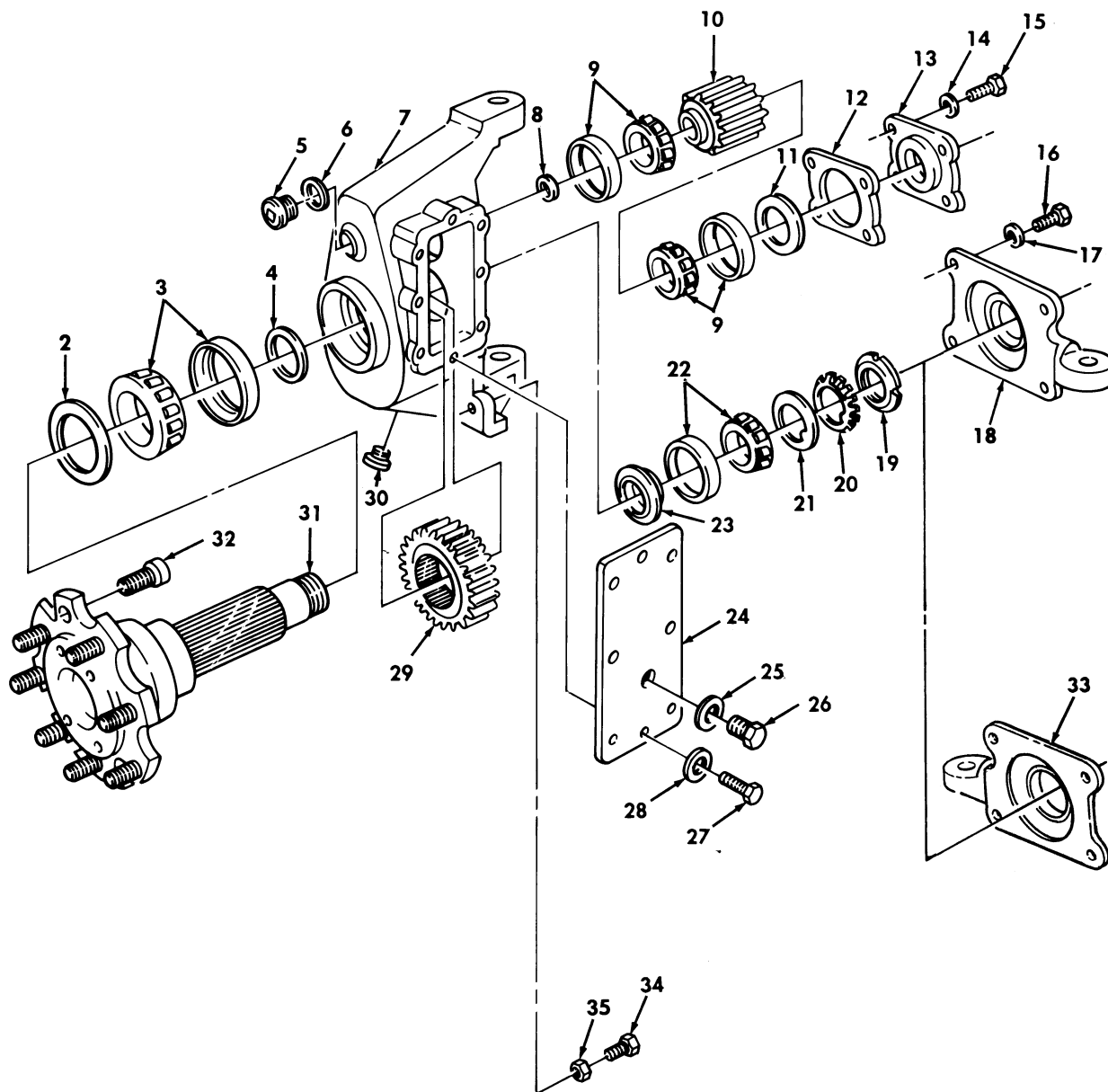

Figure 142. Front Knuckle and Geared Hub Assembly.

SECTION II			TM9-2320-280-24P			
(1)	(2)	(3)	(4)	(5)	(6)	(7)
ITEM NO	SMR CODE	NSN	CAGEC	PART NUMBER	DESCRIPTION AND USABLE ON CODES(UOC)	QTY
GROUP 1004 STEERING AND LEANING WHEEL MECHANISM						
FIG. 142 FRONT KNUCKLE AND GEARED HUB ASSEMBLY						
1	PAOFF	2530012035746	34623	5598767	SPINDLE, WHEEL, DRIVI..... UOC:AVY, A11, A13, A14, A15, A20, A24, A25, A26, A27, B16, B17, B18, HVY, H11, H13, H14, H15, H16, H17, H18, H20, H21, H24, H25, H26, H27, H28, MMM	1
2	PAOZZ	5330012036551	63769	CR 535094-60	.SEAL, PLAIN ENCASED OUTER..... UOC:AVY, A11, A13, A14, A15, A20, A24, A25, A26, A27, B16, B17, B18, HVY, H11, H13, H14, H15, H16, H17, H18, H20, H21, H24, H25, H26, H27, H28, MMM	1
3	PAFZZ	3110001005937	34623	5568228	.BEARING, ROLLER, TAPE..... UOC:AVY, A11, A13, A14, A15, A20, A24, A25, A26, A27, B16, B17, B18, HVY, H11, H13, H14, H15, H16, H17, H18, H20, H21, H24, H25, H26, H27, H28, MMM	1
4	PAFZZ	5365011748186	34623	5573989	.SPACER, RING OUTER..... UOC:AVY, A11, A13, A14, A15, A20, A24, A25, A26, A27, B16, B17, B18, HVY, H11, H13, H14, H15, H16, H17, H18, H20, H21, H24, H25, H26, H27, H28, MMM	1
5	PAOZZ	5365002777341	24617	453006	.PLUG, MACHINE THREAD UPPER..... UOC:AVY, A11, A13, A14, A15, A20, A24, A25, A26, A27, B16, B17, B18, HVY, H11, H13, H14, H15, H16, H17, H18, H20, H21, H24, H25, H26, H27, H28, MMM	1
6	PAOZZ	5310012310596	34623	5573688	.WASHER, LOCK UPPER..... UOC:AVY, A11, A13, A14, A15, A20, A24, A25, A26, A27, B16, B17, B18, HVY, H11, H13, H14, H15, H16, H17, H18, H20, H21, H24, H25, H26, H27, H28, MMM	1
7	XAFFF		34623	5593993	.KNUCKLE AND GEAR..... UOC:AVY, A11, A13, A14, A15, A20, A24, A25, A26, A27, B16, B17, B18, HVY, H11, H13, H14, H15, H16, H17, H18, H20, H21, H24, H25, H26, H27, H28, MMM	1
8	PAFZZ	5310011748632	34623	5568223	.WASHER, FLAT 1-1/4..... UOC:AVY, A11, A13, A14, A15, A20, A24, A25, A26, A27, B16, B17, B18, HVY, H11, H13, H14, H15, H16, H17, H18, H20, H21, H24, H25, H26, H27, H28, MMM	1
9	PAFZZ	3110010274475	34623	5568226	.BEARING, ROLLER, TAPE UPPER..... UOC:AVY, A11, A13, A14, A15, A20, A24, A25, A26, A27, B16, B17, B18, HVY, H11, H13, H14, H15, H16, H17, H18, H20, H21, H24, H25, H26, H27, H28, MMM	2
10	PAFZZ	3020011745985	34623	5574921	.GEAR, SPUR UPPER..... UOC:AVY, A11, A13, A14, A15, A20, A24, A25,	1

SECTION II			TM9-2320-280-24P			
(1)	(2)	(3)	(4)	(5)	(6)	(7)
ITEM	SMR			PART		
NO	CODE	NSN	CAGEC	NUMBER	DESCRIPTION AND USABLE ON CODES(UOC)	QTY
11	PAOZZ	5330014563884	80201	534059	A26,A27,B16,B17,B18,HVY,H11,H13,H14, H15,H16,H17,H18,H20,H21,H24,H25,H26, H27,H28,MMM .SEAL,PLAIN ENCASED.....	1
					UOC:AVY,A11,A13,A14,A15,A20,A24,A25, A26,A27,B16,B17,B18,HVY,H11,H13,H14, H15,H16,H17,H18,H20,H21,H24,H25,H26, H27,H28,MMM	
12	PAOZZ	5330011760825	34623	5573692	.GASKET 0.005.....	V
					UOC:AVY,A11,A13,A14,A15,A20,A24,A25, A26,A27,B16,B17,B18,HVY,H11,H13,H14, H15,H16,H17,H18,H20,H21,H24,H25,H26, H27,H28,MMM	
13	PAOZZ	5340011748493	34623	5574002	.RETAINER UPPER.....	1
					UOC:AVY,A11,A13,A14,A15,A20,A24,A25, A26,A27,B16,B17,B18,HVY,H11,H13,H14, H15,H16,H17,H18,H20,H21,H24,H25,H26, H27,H28,MMM	
14	PAOZZ	5310000806004	96906	MS27183-14	.WASHER,FLAT 3/8.....	4
					UOC:AVY,A11,A13,A14,A15,A20,A24,A25, A26,A27,B16,B17,B18,HVY,H11,H13,H14, H15,H16,H17,H18,H20,H21,H24,H25,H26, H27,H28,MMM	
15	PAOZZ	5305000680510	80204	B1821BH038C100N	.SCREW,CAP,HEXAGON H 3/8-16 X 1.00.	4
					UOC:AVY,A11,A13,A14,A15,A20,A24,A25, A26,A27,B16,B17,B18,HVY,H11,H13,H14, H15,H16,H17,H18,H20,H21,H24,H25,H26, H27,H28,MMM	
16	PAOZZ	5305000712067	80204	B1821BH050C125N	.SCREW,CAP,HEXAGON H 1/2-13 X 1.25.	4
					UOC:AVY,A11,A13,A14,A15,A20,A24,A25, A26,A27,B16,B17,B18,HVY,H11,H13,H14, H15,H16,H17,H18,H20,H21,H24,H25,H26, H27,H28,MMM	
17	PAOZZ	5310008095998	96906	MS27183-18	.WASHER,FLAT 1/2.....	4
					UOC:AVY,A11,A13,A14,A15,A20,A24,A25, A26,A27,B16,B17,B18,HVY,H11,H13,H14, H15,H16,H17,H18,H20,H21,H24,H25,H26, H27,H28,MMM	
18	PAOZZ	2530012035662	34623	5591280	.COVER,STEERING ARM L.H.....	1
					UOC:AVY,A11,A13,A14,A15,A20,A24,A25, A26,A27,B16,B17,B18,HVY,H11,H13,H14, H15,H16,H17,H18,H20,H21,H24,H25,H26, H27,H28,MMM	
19	PAOZZ	5310013825031	19207	12342680	.NUT,PLAIN,ROUND 1-3/8.....	1
					UOC:AVY,A11,A13,A14,A15,A20,A24,A25, A26,A27,B16,B17,B18,HVY,H11,H13,H14, H15,H16,H17,H18,H20,H21,H24,H25,H26, H27,H28,MMM	
20	PAOZZ	5310012134185	34623	5584462	.WASHER,KEY 1-3/8.....	1
					UOC:AVY,A11,A13,A14,A15,A20,A24,A25, A26,A27,B16,B17,B18,HVY,H11,H13,H14, H15,H16,H17,H18,H20,H21,H24,H25,H26, H27,H28,MMM	

SECTION II			TM9-2320-280-24P			
(1)	(2)	(3)	(4)	(5)	(6)	(7)
ITEM NO	SMR CODE	NSN	CAGEC	PART NUMBER	DESCRIPTION AND USABLE ON CODES(UOC)	QTY
21	PAOZZ	5310011748607	34623	5573684	.WASHER,KEY 1-3/8..... UOC:AVY,A11,A13,A14,A15,A20,A24,A25, A26,A27,B16,B17,B18,HVY,H11,H13,H14, H15,H16,H17,H18,H20,H21,H24,H25,H26, H27,H28,MMM	1
22	PAFZZ	3110001005920	34623	5568227	.BEARING,ROLLER,TAPE INNER..... UOC:AVY,A11,A13,A14,A15,A20,A24,A25, A26,A27,BVY,B15,B16,B17,B18,B20,B24, B25,C17,HVY,H11,H13,H14,H15,H16,H17, H18,H20,H21,H24,H25,H26,H27,H28,NNN	1
23	PAFZZ	5365011815085	34623	5584137	.SPACER,SLEEVE..... UOC:AVY,A11,A13,A14,A15,A20,A24,A25, A26,A27,B16,B17,B18,HVY,H11,H13,H14, H15,H16,H17,H18,H20,H21,H24,H25,H26, H27,H28,MMM	1
24	PAFZZ	5340011742271	34623	5574924	.COVER,ACCESS..... UOC:AVY,A11,A13,A14,A15,A20,A24,A25, A26,A27,B16,B17,B18,HVY,H11,H13,H14, H15,H16,H17,H18,H20,H21,H24,H25,H26, H27,H28,MMM	1
25	PAOZZ	5310011760839	34623	5573687	.WASHER,FLAT..... UOC:AVY,A11,A13,A14,A15,A20,A24,A25, A26,A27,B16,B17,B18,HVY,H11,H13,H14, H15,H16,H17,H18,H20,H21,H24,H25,H26, H27,H28,MMM	1
26	PAOZZ	5365011775720	34623	5573690	.PLUG,MACHINE THREAD..... UOC:AVY,A11,A13,A14,A15,A20,A24,A25, A26,A27,B16,B17,B18,HVY,H11,H13,H14, H15,H16,H17,H18,H20,H21,H24,H25,H26, H27,H28,MMM	1
27	PAFZZ	5306012511616	34623	5593348	.BOLT,ASSEMBLED WASH 5/16-18 X 5/8.. UOC:AVY,A11,A13,A14,A15,A20,A24,A25, A26,A27,B16,B17,B18,HVY,H11,H13,H14, H15,H16,H17,H18,H20,H21,H24,H25,H26, H27,H28,MMM	8
28	PAFZZ	5310000814219	96906	MS27183-12	.WASHER,FLAT 5/16..... UOC:AVY,A11,A13,A14,A15,A20,A24,A25, A26,A27,B16,B17,B18,HVY,H11,H13,H14, H15,H16,H17,H18,H20,H21,H24,H25,H26, H27,H28,MMM	8
29	PAFZZ	3020011745984	19207	12338723	.GEAR,SPUR LOWER..... UOC:AVY,A11,A13,A14,A15,A20,A24,A25, A26,A27,B16,B17,B18,HVY,H11,H13,H14, H15,H16,H17,H18,H20,H21,H24,H25,H26, H27,H28,MMM	1
30	PAOZZ	4730000459769	96906	MS49006-6	.PLUG,PIPE,MAGNETIC 3/8-18 X .520.. UOC:AVY,A11,A13,A14,A15,A20,A24,A25, A26,A27,B16,B17,B18,HVY,H11,H13,H14, H15,H16,H17,H18,H20,H21,H24,H25,H26, H27,H28,MMM	1
31	PAFZZ	2530011744174	34623	5579061	.SPINDLE,WHEEL,DRIVI..... UOC:AVY,A11,A13,A14,A15,A20,A24,A25, A26,A27,B16,B17,B18,HVY,H11,H13,H14,	1



SECTION II			TM9-2320-280-24P			
(1)	(2)	(3)	(4)	(5)	(6)	(7)
ITEM	SMR			PART		
NO	CODE	NSN	CAGEC	NUMBER	DESCRIPTION AND USABLE ON CODES(UOC)	QTY
32	PAOZZ	5307011964937	34623	5568211	H15,H16,H17,H18,H20,H21,H24,H25,H26, H27,H28,MMM .STUD,SELF-LOCKING 9/16-18 X 1.50..	8
					UOC:AVY,A11,A13,A14,A15,A20,A24,A25, A26,A27,B16,B17,B18,HVY,H11,H13,H14, H15,H16,H17,H18,H20,H21,H24,H25,H26, H27,H28,MMM	
33	PAOZZ	2530012035663	34623	5591279	.COVER,STEERING ARM R.H.....	1
					UOC:AVY,A11,A13,A14,A15,A20,A24,A25, A26,A27,B16,B17,B18,HVY,H11,H13,H14, H15,H16,H17,H18,H20,H21,H24,H25,H26, H27,H28,MMM	
34	PAOZZ	5305000712069	80204	B1821BH050C150N	SCREW,CAP,HEXAGON H 1/2-13 X 1.50..	2
					UOC:AVY,A11,A13,A14,A15,A20,A24,A25, A26,A27,B16,B17,B18,HVY,H11,H13,H14, H15,H16,H17,H18,H20,H21,H24,H25,H26, H27,H28,MMM	
35	PAOZZ	5310012729981	96906	MS51471-01	NUT,PLAIN,HEXAGON 1/2-13.....	2
					UOC:AVY,A11,A13,A14,A15,A20,A24,A25, A26,A27,B16,B17,B18,HVY,H11,H13,H14, H15,H16,H17,H18,H20,H21,H24,H25,H26, H27,H28,MMM	

END OF FIGURE

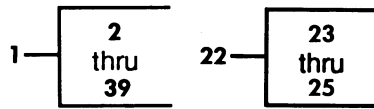

USE WITH A2 VEHICLES

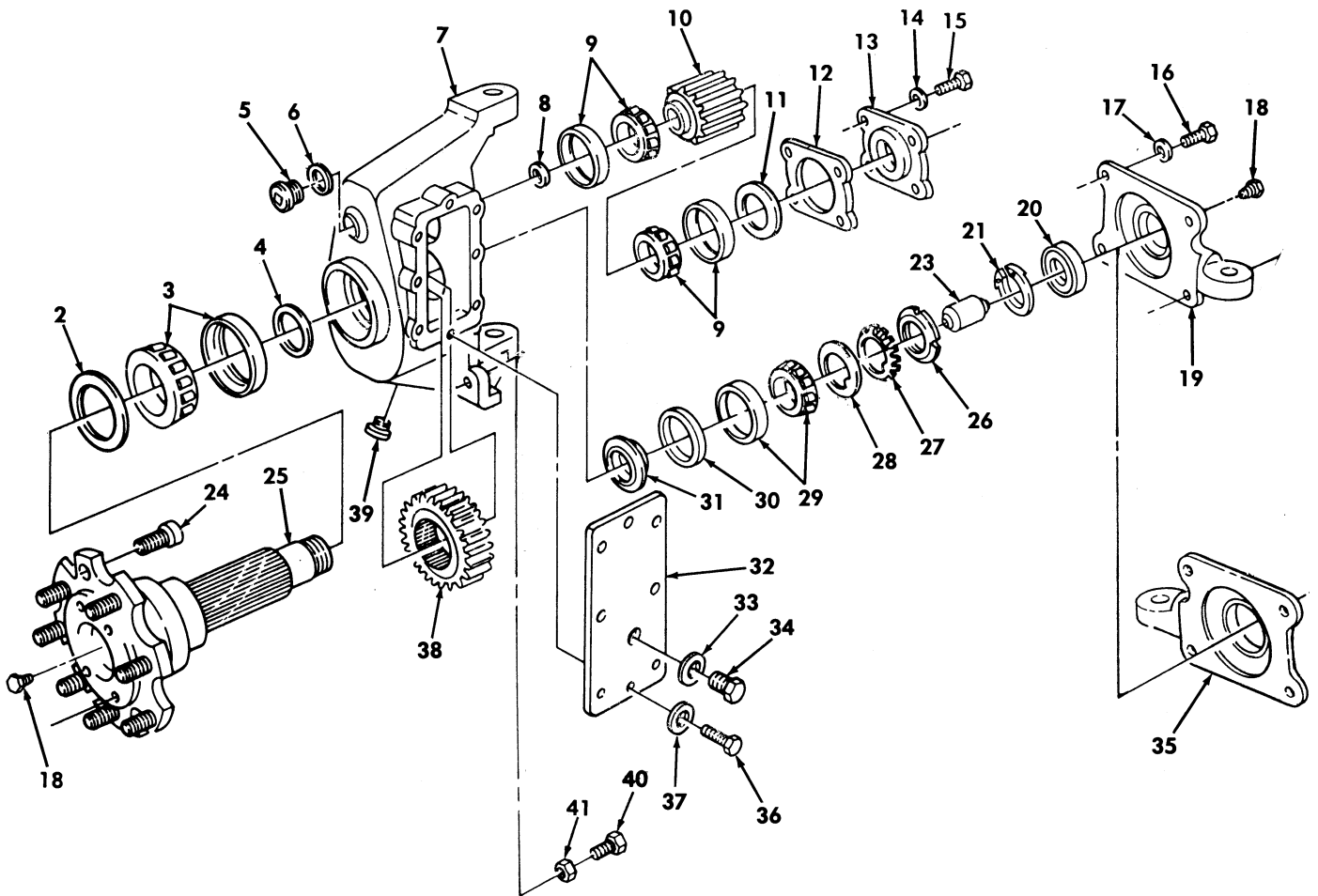

Figure 143. Front Knuckle and Geared Hub Assembly.

SECTION II			TM9-2320-280-24P			
(1)	(2)	(3)	(4)	(5)	(6)	(7)
ITEM NO	SMR CODE	NSN	CAGEC	PART NUMBER	DESCRIPTION AND USABLE ON CODES(UOC)	QTY
GROUP 1004 STEERING AND LEANING WHEEL MECHANISM						
FIG. 143 FRONT KNUCKLE AND GEARED HUB ASSEMBLY						
1	PAOFF	2530014133653	34623	6009352	SPINDLE,WHEEL,DRIVI FRONT,L.H.,FOR R.H. REPLACE ITEM 19 WITH ITEM 35... UOC:BVY,B15,B20,B24,B25,C17,NNN	2
2	PAOZZ	5330012036551	63769	CR 535095-60	.SEAL,NONMETALLIC SP..... UOC:BVY,B15,B20,B24,B25,C17,NNN	1
3	PAFZZ	3110001005937	96906	MS19081-86	.BEARING,ROLLER,TAPE..... UOC:BVY,B15,B20,B24,B25,C17,NNN	1
4	PAFZZ	5365011748186	34623	5573989	.SPACER,RING OUTER..... UOC:BVY,B15,B20,B24,B25,C17,NNN	1
5	PAOZZ	5365000777341	24617	453006	.PLUG,PIPE UPPER..... UOC:BVY,B15,B20,B24,B25,C17,NNN	1
6	PAOZZ	5310012310596	34623	5573688	.WASHER,LOCK UPPER..... UOC:BVY,B15,B20,B24,B25,C17,NNN	1
7	XAFFF		34623	5593993	.KNUCKLE AND GEAR..... UOC:BVY,B15,B20,B24,B25,C17,NNN	1
8	PAFZZ	5310014733373	34623	6009454	.SPACER,SLEEVE..... UOC:BVY,B15,B20,B24,B25,C17,NNN	1
9	PAFZZ	3110010274475	34623	5568226	.BEARING,ROLLER,TAPE UPPER..... UOC:BVY,B15,B20,B24,B25,C17,NNN	2
10	PAFZZ	3020014322553	34623	6009453	.GEAR,SPUR UPPER..... UOC:BVY,B15,B20,B24,B25,C17,NNN	1
11	PAOZZ	5330011809099	73680	2994-2106	.SEAL,PLAIN UPPER..... UOC:BVY,B15,B20,B24,B25,C17,NNN	1
12	PAOZZ	5330011760825	34623	5573692	.GASKET 0.005..... UOC:BVY,B15,B20,B24,B25,C17,NNN	V
13	PAOZZ	5340011748493	34623	5574002	.RETAINER UPPER..... UOC:BVY,B15,B20,B24,B25,C17,NNN	1
14	PAOZZ	5310000806004	96906	MS27183-14	.WASHER,FLAT UPPER,3/8..... UOC:BVY,B15,B20,B24,B25,C17,NNN	4
15	PAOZZ	5305000680510	80204	B1821BH038C100N	.SCREW,CAP,HEXAGON H UPPER,3/8-16 X 1.00..... UOC:BVY,B15,B20,B24,B25,C17,NNN	4
16	PAOZZ	5305000712067	80204	B1821BH050C125N	.SCREW,CAP,HEXAGON H 1/2-13 X 1.25. UOC:BVY,B15,B20,B24,B25,C17,NNN	4
17	PAOZZ	5310008095998	96906	MS27183-18	.WASHER,FLAT 1/2..... UOC:BVY,B15,B20,B24,B25,C17,NNN	4
18	PAOZZ	4730000127951	93334	127951	.PLUG,PIPE..... UOC:BVY,B15,B20,B24,B25,C17,NNN	2
19	PAOZZ	2530014338705	34623	6005121	.COVER,STEERING L.H..... UOC:BVY,B15,B20,B24,B25,C17,NNN	1
20	PAOZZ	5330014568823	34623	6005193	.SEAL ASSEMBLY,SPINDLE..... UOC:BVY,B15,B20,B24,B25,C17,NNN	1
21	PAOZZ	5325005141299	79136	5008-125MD	.RING,RETAINING..... UOC:BVY,B15,B20,B24,B25,C17,NNN	1
22	PAOZZ	2530014492495	34623	5715160	.SPINDLE AND STUD ASSEMBLY..... UOC:BVY,B15,B20,B24,B25,C17,NNN	1
23	PAOZZ	5365014142902	34623	5594531	..SPACER,SLEEVE.....	1

SECTION II			TM9-2320-280-24P			
(1)	(2)	(3)	(4)	(5)	(6)	(7)
ITEM	SMR			PART		
NO	CODE	NSN	CAGEC	NUMBER	DESCRIPTION AND USABLE ON CODES(UOC)	QTY
24	PAOZZ	5307011964937	34623	5568211	UOC:BVY,B15,B20,B24,B25,C17,NNN . .STUD,SELF-LOCKING 9/16-18 X 1.50.	8
25	XAOZZ		34623	6009349	UOC:BVY,B15,B20,B24,B25,C17,NNN . .SPINDLE,WHEEL,DRIVI.....	1
26	PAOZZ	5310013825031	19207	12342680	UOC:BVY,B15,B20,B24,B25,C17,NNN .NUT,PLAIN,ROUND.....	1
27	PAOZZ	5310012134185	34623	5584462	UOC:BVY,B15,B20,B24,B25,C17,NNN .WASHER,KEY 1-3/8.....	1
28	PAOZZ	5310011748607	34623	5573684	UOC:BVY,B15,B20,B24,B25,C17,NNN .WASHER,KEY 1-3/8.....	1
29	PAOZZ	3110001005920	34623	5568227	UOC:BVY,B15,B20,B24,B25,C17,NNN .BEARING,ROLLER TAPE INNER.....	1
30	PAOZZ	5365014562032	34623	6001784	UOC:BVY,B15,B20,B24,B25,C17,NNN .SPACER,RING.....	1
31	PAOZZ	5365014142895	34623	06009350	UOC:BVY,B15,B20,B24,B25,C17,NNN .SPACER,SLEEVE.....	1
32	PAOZZ	5340011742271	34623	5574924	UOC:BVY,B15,B20,B24,B25,C17,NNN .COVER,ACCESS.....	1
33	PAOZZ	5310011760839	34623	5573687	UOC:BVY,B15,B20,B24,B25,C17,NNN .WASHER,FLAT.....	1
34	PAOZZ	5365011775720	34623	5573690	UOC:BVY,B15,B20,B24,B25,C17,NNN .PLUG,MACHINE THREAD.....	1
35	PAOZZ	2530014338003	34623	6005120	UOC:BVY,B15,B20,B24,B25,C17,NNN .ARM,CONTROL R.H.....	1
36	PAOZZ	5306002264823	80204	B1821BH031C056N	UOC:BVY,B15,B20,B24,B25,C17,NNN .BOLT,MACHINE 5/16-18 X 5/8.....	8
37	PAOZZ	5310000814219	96906	MS27183-12	UOC:BVY,B15,B20,B24,B25,C17,NNN .WASHER,FLAT 5/16.....	8
38	PAFZZ	3020014762701	34623	6009452	UOC:BVY,B15,B20,B24,B25,C17,NNN .GEAR,SPUR.LOWER.....	1
39	PAOZZ	4730000459769	96906	MS49006-6	UOC:BVY,B15,B20,B24,B25,C17,NNN .PLUG,PIPE,MAGNETIC.....	1
40	PAOZZ	5305000712069	80204	B1821BH050C150N	UOC:BVY,B15,B20,B24,B25,C17,NNN SCREW,CAP,HEXAGON H 1/2-13 X 1.50...	2
41	PAOZZ	5310012729981	96906	MS51471-01	UOC:BVY,B15,B20,B24,B25,C17,NNN NUT,PLAIN,HEXAGON 1/2-13.....	2

END OF FIGURE

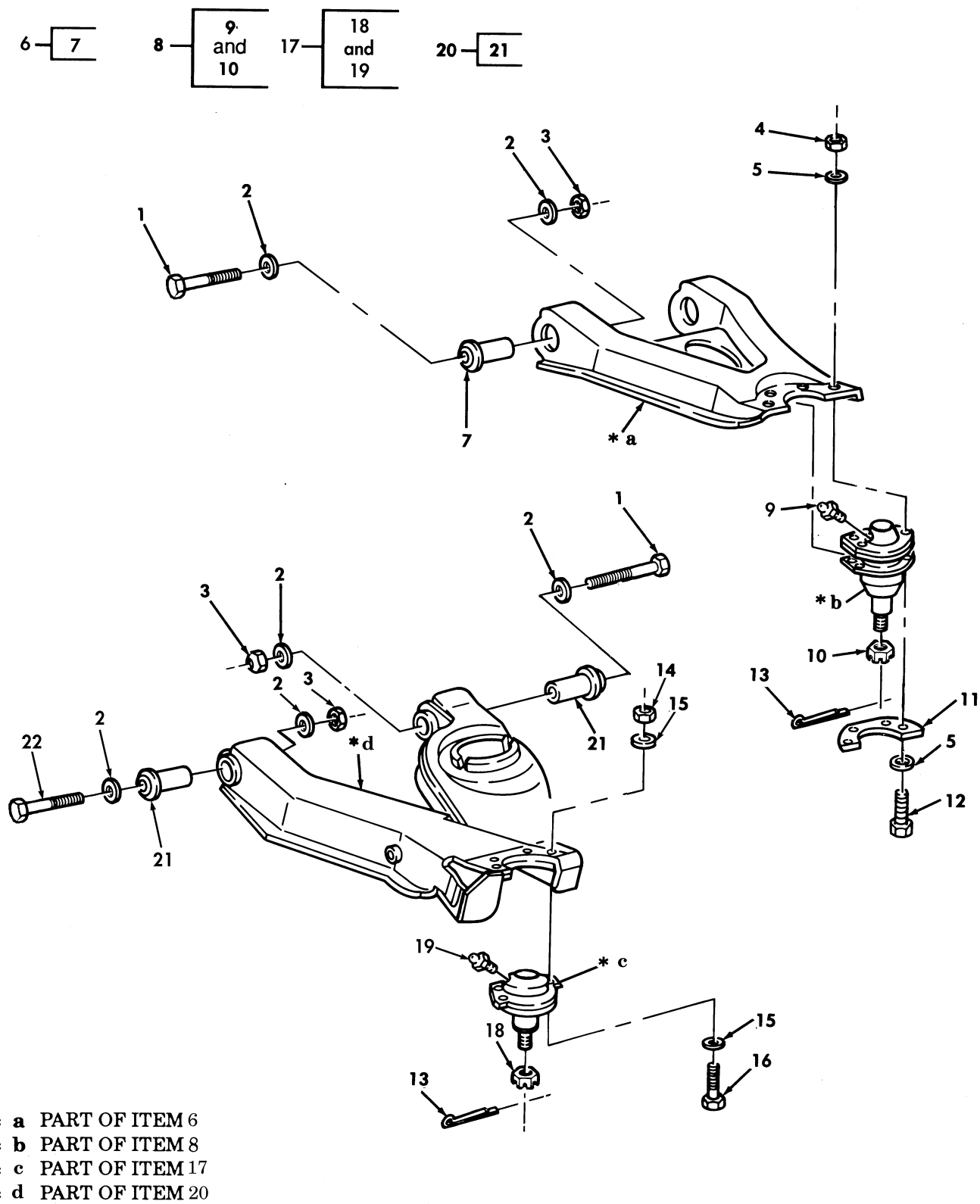

Figure 144. Front Control Arms, Ball Joints, and Mounting Hardware.

SECTION II			TM9-2320-280-24P			
(1)	(2)	(3)	(4)	(5)	(6)	(7)
ITEM	SMR			PART		
NO	CODE	NSN	CAGEC	NUMBER	DESCRIPTION AND USABLE ON CODES(UOC)	QTY
GROUP 1004 STEERING AND LEANING WHEEL MECHANISM						
FIG. 144 FRONT CONTROL ARMS,BALL JOINTS,AND MOUNTING HARDWARE						
1	PAOZZ	5305009474361	80204	B1821BH075C475N	SCREW,CAP,HEXAGON H 3/4-10 X 4.75..	6
2	PAOZZ	5310011474052	23862	2436168	WASHER,FLAT 3/4.....	16
3	PAOZZ	5310004093333	96906	MS51943-45	NUT,SELF-LOCKING,HE 3/4-10.....	8
4	PAOZZ	5310008140673	96906	MS51943-35	NUT,SELF-LOCKING,HE 5/16-18.....	8
					UOC:AVY,A11,A13,A14,A15,A20,A24,A25,A26,A27,B16,B17,B18,HVY,H11,H13,H14,H15,H16,H17,H18,H20,H21,H24,H25,H26,H27,H28,MMM	
4	PAOZZ	5310008140672	96906	MS51943-36	NUT,SELF-LOCKING,HE 3/8-24.....	8
					UOC:BVY,B15,B20,B24,B25,C17,NNN	
5	PAOZZ	5310011191024	24617	2436162	WASHER,FLAT 5/16.....	16
					UOC:AVY,A11,A13,A14,A15,A20,A24,A25,A26,A27,B16,B17,B18,HVY,H11,H13,H14,H15,H16,H17,H18,H20,H21,H24,H25,H26,H27,H28,MMM	
5	PAOZZ	5310014124013	24617	2436163	WASHER,FLAT 3/8.....	16
					UOC:BVY,B15,B20,B24,B25,C17,NNN	
6	PAOFF	2530011757211	34623	5584769	ARM,CONTROL,VEHICUL FRONT,L.H.....	1
					UOC:AVY,A11,A13,A14,A15,A20,A24,A25,A26,A27,B16,B17,B18,HVY,H11,H13,H14,H15,H16,H17,H18,H20,H21,H24,H25,H26,H27,H28,MMM	
6	PAOFF	2530011764650	34623	5584770	ARM,CONTROL,VEHICUL FRONT,R.H.....	1
					UOC:AVY,A11,A13,A14,A15,A20,A24,A25,A26,A27,B16,B17,B18,HVY,H11,H13,H14,H15,H16,H17,H18,H20,H21,H24,H25,H26,H27,H28,MMM	
6	PAOFF	2530014147844	19207	12460167	ARM,CONTROL,VEHICUL FRONT,L.H.....	1
					UOC:BVY,B15,B20,B24,B25,C17,NNN	
6	PAOFF	2530014131365	19207	12460151	ARM,CONTROL,VEHICUL FRONT,R.H.....	1
					UOC:BVY,B15,B20,B24,B25,C17,NNN	
7	PAFZZ	3120011865527	19207	12338270	.BUSHING,SLEEVE.....	2
8	PAOZZ	2530011883685	98349	C-205-TEZ-35	PARTS KIT,BALL JOIN.....	2
					UOC:AVY,A11,A13,A14,A15,A20,A24,A25,A26,A27,B16,B17,B18,HVY,H11,H13,H14,H15,H16,H17,H18,H20,H21,H24,H25,H26,H27,H28,MMM	
8	PAOZZ	2530014131366	34623	6007755	PARTS KIT,BALL JOIN.....	2
					UOC:BVY,B15,B20,B24,B25,C17,NNN	
9	PAOZZ	4730000504203	96906	MS15001-1	.FITTING,LUBRICATION.....	1
10	PAOZZ	5310008507004	96906	MS35692-54	.NUT,PLAIN,SLOTTED,H 5/8-18.....	1
11	PAOZZ	2530012101324	19207	12338320	RETAINER,BALL JOINT UPPER.....	2
					UOC:AVY,A11,A13,A14,A15,A20,A24,A25,A26,A27,B16,B17,B18,HVY,H11,H13,H14,H15,H16,H17,H18,H20,H21,H24,H25,H26,H27,H28,MMM	
12	PAOZZ	5305014125994	19207	12460159	SCREW,CAP,HEXAGON H 3/8-24 X 1.375.	8
					UOC:BVY,B15,B20,B24,B25,C17,NNN	
12	PAOZZ	5306002264829	80204	B1821BH031C125N	SCREW,CAP,HEXAGON H 5/16-18 X 1.125	8

SECTION II			TM9-2320-280-24P			
(1)	(2)	(3)	(4)	(5)	(6)	(7)
ITEM NO	SMR CODE	NSN	CAGEC	PART NUMBER	DESCRIPTION AND USABLE ON CODES(UOC)	QTY
					UOC:AVY,A11,A13,A14,A15,A20,A24,A25,A26,A27,B16,B17,B18,HVY,H11,H13,H14,H15,H16,H17,H18,H20,H21,H24,H25,H26,H27,H28,MMM	
13	PAOZZ	5315000120123	96906	MS24665-355	PIN,COTTER 1/8 X 1-1/4.....	4
14	PAOZZ	5310009359021	96906	MS51943-35	NUT,SELF-LOCKING,HE 3/8-16.....	8
					UOC:AVY,A11,A13,A14,A15,A20,A24,A25,A26,A27,B16,B17,B18,HVY,H11,H13,H14,H15,H16,H17,H18,H20,H21,H24,H25,H26,H27,H28,MMM	
14	PAOZZ	5310011504003	24617	9422299	NUT,SELF-LOCKING,HE 7/16-14 UNC....	8
					UOC:BVY,B15,B20,B24,B25,C17,NNN	
15	PAOZZ	5310014124013	24617	2436163	WASHER,FLAT 3/8.....	16
					UOC:AVY,A11,A13,A14,A15,A20,A24,A25,A26,A27,B16,B17,B18,HVY,H11,H13,H14,H15,H16,H17,H18,H20,H21,H24,H25,H26,H27,H28,MMM	
15	PAOZZ	5310008094085	24617	2436164	WASHER,FLAT 7/16.....	16
					UOC:BVY,B15,B20,B24,B25,C17,NNN	
16	PAOZZ	5305006882111	80204	B1821BH038C138N	SCREW,CAP,HEXAGON H 3/8-16 X 1.375.	8
					UOC:AVY,A11,A13,A14,A15,A20,A24,A25,A26,A27,B16,B17,B18,HVY,H11,H13,H14,H15,H16,H17,H18,H20,H21,H24,H25,H26,H27,H28,MMM	
16	PAOZZ	5305000712055	80204	B1821BH044C150N	SCREW,CAP,HEXAGON H 7/16-14 X 1.50.	8
					UOC:BVY,B15,B20,B24,B25,C17,NNN	
17	PAOZZ	3040014229390	34623	6006645	BALL JOINT LOWER.....	2
					UOC:BVY,B15,B20,B24,B25,C17,NNN	
17	PAOZZ	3040011883684	19207	12338328	PARTS KIT,BALL JOIN LOWER.....	2
					UOC:H11,H13,H14,H15,H16,H17,H18,H20,H21,H24,H25,H26,H27,H28,MMM	
17	PAOZZ	3040013582102	19207	12342645	BALL JOINT.....	2
					UOC:AVY,A11,A13,A14,A15,A20,A24,A25,A26,A27,B16,B17,B18,HVY	
18	PAOZZ	5310008507004	96906	MS35692-54	.NUT,PLAIN,SLOTTED,H 5/8-18.....	1
19	PAOZZ	4730000504203	96906	MS15001-1	.FITTING,LUBRICATION.....	1
20	PAOFF	2530011757212	34623	5579475	ARM,CONTROL,VEHICUL LOWER FRONT, R.H.....	1
					UOC:AVY,A11,A13,A14,A15,A20,A24,A25,A26,A27,B16,B17,B18,HVY,H11,H13,H14,H15,H16,H17,H18,H20,H21,H24,H25,H26,H27,H28,MMM	
20	PAOFF	2530011757213	34623	5579474	ARM,CONTROL,VEHICUL LOWER FRONT, L.H.....	1
					UOC:AVY,A11,A13,A14,A15,A20,A24,A25,A26,A27,B16,B17,B18,HVY,H11,H13,H14,H15,H16,H17,H18,H20,H21,H24,H25,H26,H27,H28,MMM	
20	PAOFF	2530014207895	34623	RCSK17250	ARM,CONTROL,VEHICUL LOWER FRONT L.H.	1
					UOC:BVY,B15,B20,B24,B25,C17,NNN	
20	PAOFF	2530014208634	34623	RCSK17249	ARM,CONTROL,VEHICUL LOWER FRONT R.H.	1
					UOC:BVY,B15,B20,B24,B25,C17,NNN	
21	PAFZZ	3120011865527	19207	12338270	.BUSHING,SLEEVE LOWER.....	2
22	PAOZZ	5305009474362	80204	B1821BH075C500N	SCREW,CAP,HEXAGON H 3/4-10 X 5.00..	2

END OF FIGURE

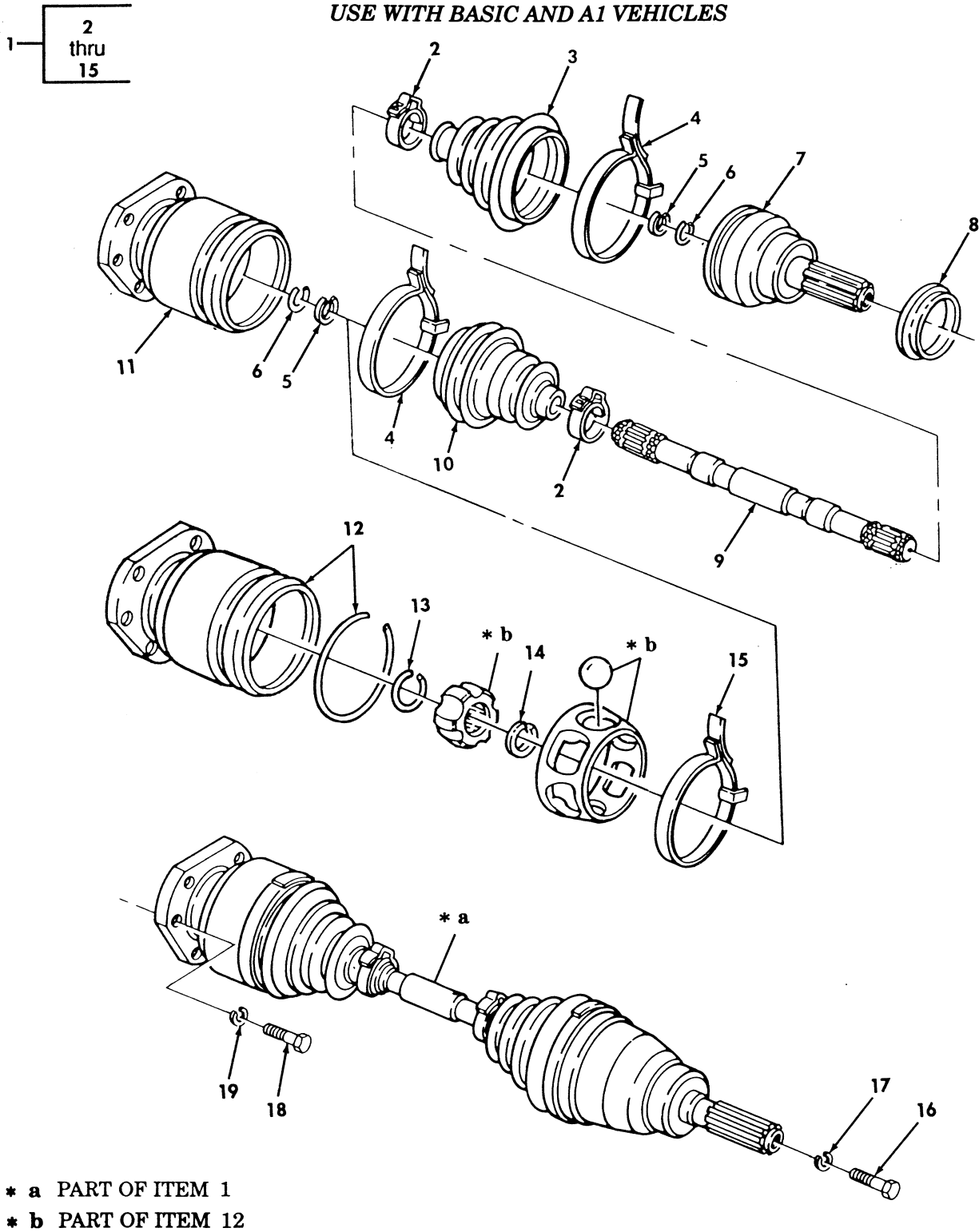

Figure 145. Rear Halfshaft Assembly, Left and Right Side.



SECTION II			TM9-2320-280-24P			
(1)	(2)	(3)	(4)	(5)	(6)	(7)
ITEM	SMR			PART		
NO	CODE	NSN	CAGEC	NUMBER	DESCRIPTION AND USABLE ON CODES(UC)	QTY
					GROUP 11 REAR AXLE 1100 REAR AXLE ASSEMBLY	
					FIG. 145 REAR HALFSHAFT ASSEMBLY, LEFT AND RIGHT SIDE	
1	PAOOO	2520013832387	62826	2980302	PARTS KIT,CONSTANT REAR,L.H. AND R.H..... UC:AVY,A11,A13,A14,A15,A20,A24,A25, A26,A27,B16,B17,B18,HVY,H11,H13,H14, H15,H16,H17,H18,H20,H21,H24,H25,H26, H27,H28,MMM	2
2	KFOZZ		34623	5741547	.CLAMP,RACE USE WITH P/N 12341985-3 PART OF KIT P/N 5705606 PART OF KIT P/N 287-0006..... UC:H11,H13,H14,H15,H16,H17,H18,H20, H21,H24,H25,H26,H27,H28,MMM	2
2	PAOZZ	5340014241300	62826	1400164	.CLAMP,RACE 33.7 MM PART OF KIT P/N 57K0274 PART OF KIT P/N 2880019..... UC:AVY,A11,A13,A14,A15,A20,A24,A25, A26,A27,B16,B17,B18,HVY,H11,H13,H14, H15,H16,H17,H18,H20,H21,H24,H25,H26, H27,H28,MMM	1
3	KFOZZ		34623	5740258	.BOOT,FIXED USE WITH P/N 12341985-3 PART OF KIT P/N 287-0006..... UC:H11,H13,H14,H15,H16,H17,H18,H20, H21,H24,H25,H26,H27,H28,MMM	2
3	KFOZZ		62826	2880015	.BOOT,FIXED PART OF KIT P/N 2880019 UC:AVY,A11,A13,A14,A15,A20,A24,A25, A26,A27,B16,B17,B18,HVY,H11,H13,H14, H15,H16,H17,H18,H20,H21,H24,H25,H26, H27,H28,MMM	1
4	KFOZZ		34623	5741548	.CLAMP,RIM CLENCHING USE WITH P/N 12341985-3 PART OF KIT P/N 5705606 PART OF KIT P/N 287-0006..... UC:H11,H13,H14,H15,H16,H17,H18,H20, H21,H24,H25,H26,H27,H28,MMM	2
4	PAOZZ	5340014211423	62826	1400165	.CLAMP,LOOP 99.8 MM PART OF KIT P/N 2880019..... UC:AVY,A11,A13,A14,A15,A20,A24,A25, A26,A27,B16,B17,B18,HVY,H11,H13,H14, H15,H16,H17,H18,H20,H21,H24,H25,H26, H27,H28,MMM	1
5	PAOZZ	5365013831925	34623	5740549	.SPACER,RING USE WITH P/N 12341985- 3 PART OF KIT P/N 5741095..... UC:H11,H13,H14,H15,H16,H17,H18,H20, H21,H24,H25,H26,H27,H28,MMM	2
6	PAOZZ	5325012122403	34623	5741098	.RING,RETAINING USE WITH P/N 12341985-3 PART OF KIT P/N 5741095.. UC:H11,H13,H14,H15,H16,H17,H18,H20, H21,H24,H25,H26,H27,H28,MMM	2
7	PFOZZ	3040011891637	34623	5740551	.JOINT ASSEMBLY,DIFF USE WITH P/N 12341985-3..... UC:H11,H13,H14,H15,H16,H17,H18,H20,	1

SECTION II			TM9-2320-280-24P			
(1)	(2)	(3)	(4)	(5)	(6)	(7)
ITEM NO	SMR CODE	NSN	CAGEC	PART NUMBER	DESCRIPTION AND USABLE ON CODES(UOC)	QTY
8	PAOZZ	2530012969333	34623	5598209	H21,H24,H25,H26,H27,H28,MMM .DEFLECTOR,DIRT AND.....	1
					UOC:AVY,A11,A13,A14,A15,A20,A24,A25, A26,A27,B16,B17,B18,HVY,H11,H13,H14, H15,H16,H17,H18,H20,H21,H24,H25,H26, H27,H28,MMM	
9	PFOZZ	3040011883607	34623	5740256	.SHAFT,SHOULDERED REAR,USE WITH P/ N 12341985-3 PART OF KIT P/N 5741095	1
					UOC:H11,H13,H14,H15,H16,H17,H18,H20, H21,H24,H25,H26,H27,H28,MMM	
10	KFOZZ		34623	5740257	.BOOT,PLUNGE USE WITH P/N 12341985- 3 PART OF KIT P/N 5705606.....	1
					UOC:H11,H13,H14,H15,H16,H17,H18,H20, H21,H24,H25,H26,H27,H28,MMM	
10	KFOZZ		62826	2880016	.BOOT,PLUNGE PART OF KIT P/N 57K0274 PART OF KIT P/N 2880019.....	1
					UOC:AVY,A11,A13,A14,A15,A20,A24,A25, A26,A27,B16,B17,B18,HVY,H11,H13,H14, H15,H16,H17,H18,H20,H21,H24,H25,H26, H27,H28,MMM	
11	PFOZZ	2520011891636	34623	5740550	.JOINT ASSEMBLY,DIFF USE WITH P/N 12341985-3.....	1
					UOC:H11,H13,H14,H15,H16,H17,H18,H20, H21,H24,H25,H26,H27,H28,MMM	
12	PFOZZ		62826	2180007	.JOINT ASSEMBLY USE WITH P/N 2980302	1
					UOC:AVY,A11,A13,A14,A15,A20,A24,A25, A26,A27,B16,B17,B18,HVY,H11,H13,H14, H15,H16,H17,H18,H20,H21,H24,H25,H26, H27,H28,MMM	
13	KFOZZ		62826	2080021	.RING,RETAINER PART OF KIT P/N 57K0274 PART OF KIT P/N 2880019.....	2
					UOC:AVY,A11,A13,A14,A15,A20,A24,A25, A26,A27,B16,B17,B18,HVY,H11,H13,H14, H15,H16,H17,H18,H20,H21,H24,H25,H26, H27,H28,MMM	
14	KFOZZ		62826	2080007	.SPACER,RING PART OF KIT P/N 57K0274 PART OF KIT P/N 2880019.....	2
					UOC:AVY,A11,A13,A14,A15,A20,A24,A25, A26,A27,B16,B17,B18,HVY,H11,H13,H14, H15,H16,H17,H18,H20,H21,H24,H25,H26, H27,H28,MMM	
15	KFOZZ		62826	1400166	.CLAMP,LOOP 96.5 MM PART OF KIT P/N 57K0274 PART OF KIT P/N 2880019.....	1
					UOC:AVY,A11,A13,A14,A15,A20,A24,A25, A26,A27,B16,B17,B18,HVY,H11,H13,H14, H15,H16,H17,H18,H20,H21,H24,H25,H26, H27,H28,MMM	
16	PAOZZ	5305000680511	80204	B1821BH038C125N	SCREW,CAP,HEXAGON H 3/8-16 X 1.125.	2
17	PAOZZ	5310000115093	96906	MS35338-65	WASHER,LOCK 3/8.....	2
18	PAOZZ	5306011857048	7X677	11513606	BOLT,MACHINE 10-1.5 X 35 MM.....	12
19	PAOZZ	5310011857218	7X677	11500177	WASHER,LOCK 10 MM.....	12

END OF FIGURE

USE WITH A2 VEHICLES

1 — 2 thru 12

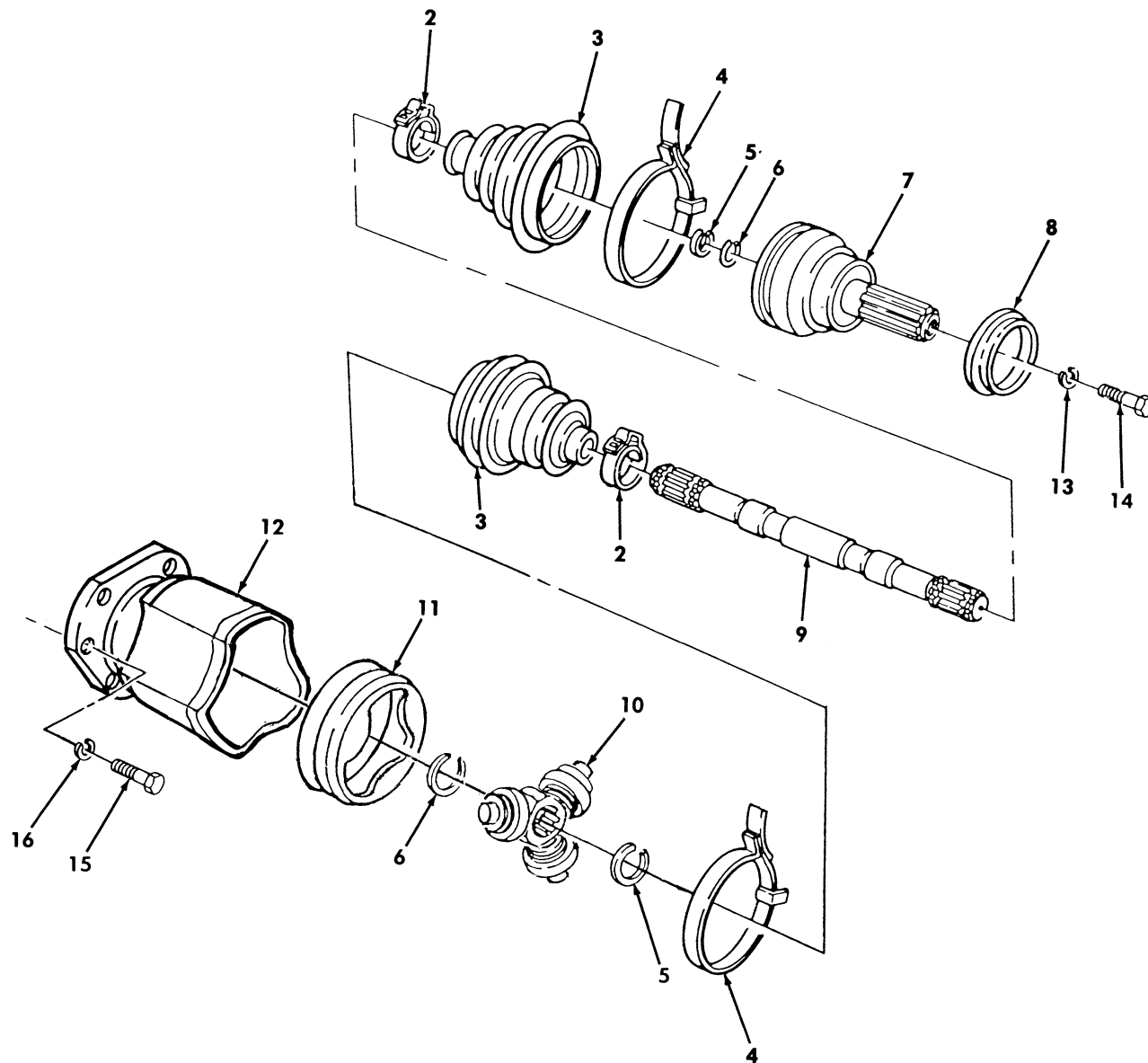
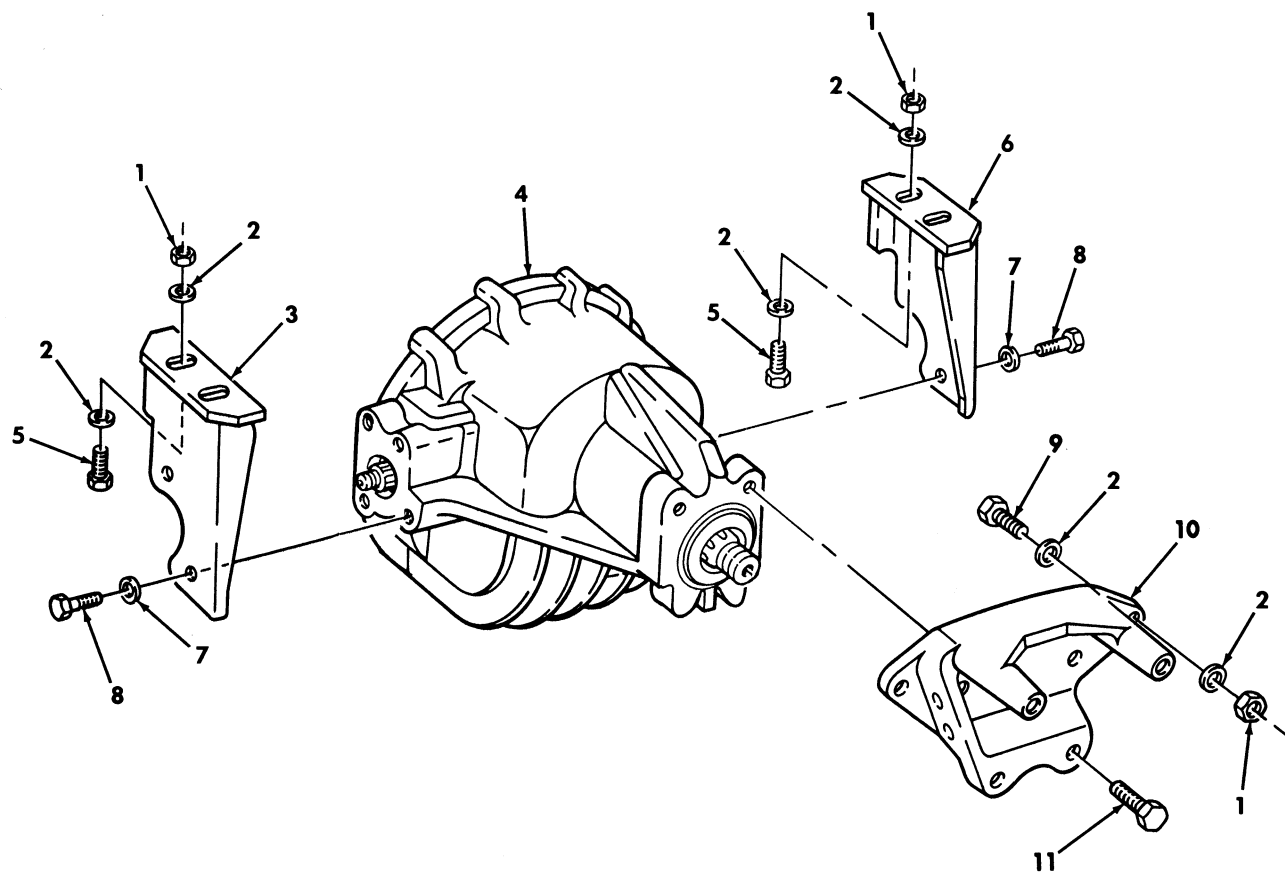

Figure 146. Rear Halfshaft Assembly, Left and Right Side.

SECTION II			TM9-2320-280-24P			
(1)	(2)	(3)	(4)	(5)	(6)	(7)
ITEM NO	SMR CODE	NSN	CAGEC	PART NUMBER	DESCRIPTION AND USABLE ON CODES(UCO)	QTY
GROUP 1100 REAR AXLE ASSEMBLY						
FIG. 146 REAR HALFSHAFT ASSEMBLY, LEFT AND RIGHT SIDE						
1	PAOOO	2520014214589	34623	RCSK17028-1	SHAFT,AXLE,AUTOMOTI REAR.....	2
					UCO:BVY,B15,B20,B24,B25,C17,NNN	
2	KFOZZ		62826	1400270	.CLAMP,BOOT 35.1MM PART OF KIT P/N	2
					2990056 PART OF KIT P/N 57K3515.....	
					UCO:BVY,B15,B20,B24,B25,C17,NNN	
3	KFOZZ		62826	2890019	.BOOT PART OF KIT P/N 2990056 PART	2
					OF KIT P/N 57K3515.....	
					UCO:BVY,B15,B20,B24,B25,C17,NNN	
4	KFOZZ		62826	1400271	.PARTS KIT,DUST BOOT 106.8MM PART	2
					OF KIT P/N 2990054 PART OF KIT P/N	
					57K3515.....	
					UCO:BVY,B15,B20,B24,B25,C17,NNN	
5	KFOZZ		62826	2090004	.RING,SPACER PART OF KIT P/N 2390077	2
					PART OF KIT P/N 2990056 PART OF KIT	
					P/N 57K3515.....	
					UCO:BVY,B15,B20,B24,B25,C17,NNN	
6	KFOZZ		62826	2090003	.RING,RETAINING PART OF KIT P/N	2
					2990054 PART OF KIT P/N 57K3515.....	
					UCO:BVY,B15,B20,B24,B25,C17,NNN	
7	KFOZZ		62826	2290033	.JOINT ASSEMBLY FIXED PART OF KIT	1
					P/N 2990054 PART OF KIT P/N 2990055	
					PART OF KIT P/N 2990056.....	
					UCO:BVY,B15,B20,B24,B25,C17,NNN	
8	PAOZZ	2530012969333	34623	5598209	.DEFLECTOR,DIRT AND PART OF KIT P/N	1
					2990056.....	
					UCO:BVY,B15,B20,B24,B25,C17,NNN	
9	KFOZZ		62826	2790028	.SHAFT,SHOULDERED PART OF KIT P/N	1
					2990056.....	
					UCO:BVY,B15,B20,B24,B25,C17,NNN	
10	KFOZZ		62826	2390036	.SPIDER ASSEMBLY PART OF KIT P/N	1
					2390077.....	
					UCO:BVY,B15,B20,B24,B25,C17,NNN	
11	KFOZZ		62826	2390076	.INSERT PART OF KIT P/N 2390077....	1
					UCO:BVY,B15,B20,B24,B25,C17,NNN	
12	KFOZZ		62826	2390079	.JOINT,PLUNGE PART OF KIT P/N	1
					2390077.....	
					UCO:BVY,B15,B20,B24,B25,C17,NNN	
13	PAOZZ	5310000115093	96906	MS35338-65	WASHER,LOCK 3/8.....	2
					UCO:BVY,B15,B20,B24,B25,C17,NNN	
14	PAOZZ	5305000680511	80204	B1821BH038C125N	SCREW,CAP,HEXAGON H 3/8-16 X 1.125.	2
					UCO:BVY,B15,B20,B24,B25,C17,NNN	
15	PAOZZ	5306011857048	7X677	11513606	BOLT,MACHINE 10-1.5 X 35MM.....	12
					UCO:BVY,B15,B20,B24,B25,C17,NNN	
16	PAOZZ	5310011857218	7X677	11500177	WASHER,LOCK 10MM.....	12
					UCO:BVY,B15,B20,B24,B25,C17,NNN	

END OF FIGURE



FOR BREAKDOWN PARTS OF  
ITEM 4, SEE FIGURE 148

Figure 147. Rear Axle Differential, Mounting Brackets, and Hardware.

SECTION II			TM9-2320-280-24P			
(1)	(2)	(3)	(4)	(5)	(6)	(7)
ITEM	SMR			PART		
NO	CODE	NSN	CAGEC	NUMBER	DESCRIPTION AND USABLE ON CODES(UOC)	QTY
GROUP 1102 DIFFERENTIAL						
FIG. 147 REAR AXLE DIFFERENTIAL, MOUNTING BRACKETS,AND HARDWARE						
1	PAFZZ	5310004883889	96906	MS51943-39	NUT,SELF-LOCKING,HE 1/2-13.....	6
2	PAFZZ	5310008898782	34623	5593416	WASHER,FLAT 1/2.....	12
3	PFFZZ	5342012779102	34623	5597142	BRACKET,REAR AXLE.....	1
3	PAFZZ	2590013948134	34623	12338151-7	BRACKET,VEHICULAR C R.H.....	1
4	PAFHH	2520013583160	34623	5597777	AXLE ASSEMBLY,AUTOM REAR.....	1
					UOC:AVY,A11,A13,A14,A15,A20,A24,A25, A26,A27,BVY,B15,B16,B17,B18,B20,B24, B25,C17,HVY,NNN	
4	PAFHH	2520012912975	19207	12338415-3	DIFFERENTIAL,DRIVIN.....	1
					UOC:H11,H13,H14,H15,H16,H17,H18,H20, H21,H24,H25,H26,H27,H28,MMM	
5	PAFZZ	5305000712067	80204	B1821BH050C125N	SCREW,CAP,HEXAGON H 1/2-13 X 1.25..	4
6	PFFZZ	5342012779101	19207	12338151-1	BRACKET,REAR AXLE L.H.....	1
7	PAFZZ	5310011517347	24617	2436167	WASHER,FLAT 5/8.....	6
8	PAFZZ	5305007247219	80204	B1821BH063C125N	SCREW,CAP,HEXAGON H 5/8-11 X 1.25..	6
9	PAFZZ	5305000712076	80204	B1821BH050C325N	SCREW,CAP,HEXAGON H 1/2-13 X 3.25..	2
					UOC:H11,H13,H14,H17,H18,H20,H24,H25, H26,H27,MMM	
9	PAFZZ	5305000712066	80204	B1821BH050C100N	SCREW,CAP,HEXAGON H 1/2-13 X 1.00..	2
					UOC:AVY,A11,A13,A14,A15,A20,A24,A25, A26,A27,BVY,B15,B16,B17,B18,B20,B24, B25,C17,HVY,NNN	
10	PAFZZ	5340013017929	19207	12341900	BRACKET,MOUNTING.....	1
11	PAFZZ	5305007247220	80204	B1821BH063C150N	SCREW,CAP,HEXAGON H 5/8-11 X 1-1/2.	2

END OF FIGURE

Section II.

TM 9-2320-280-24P-1

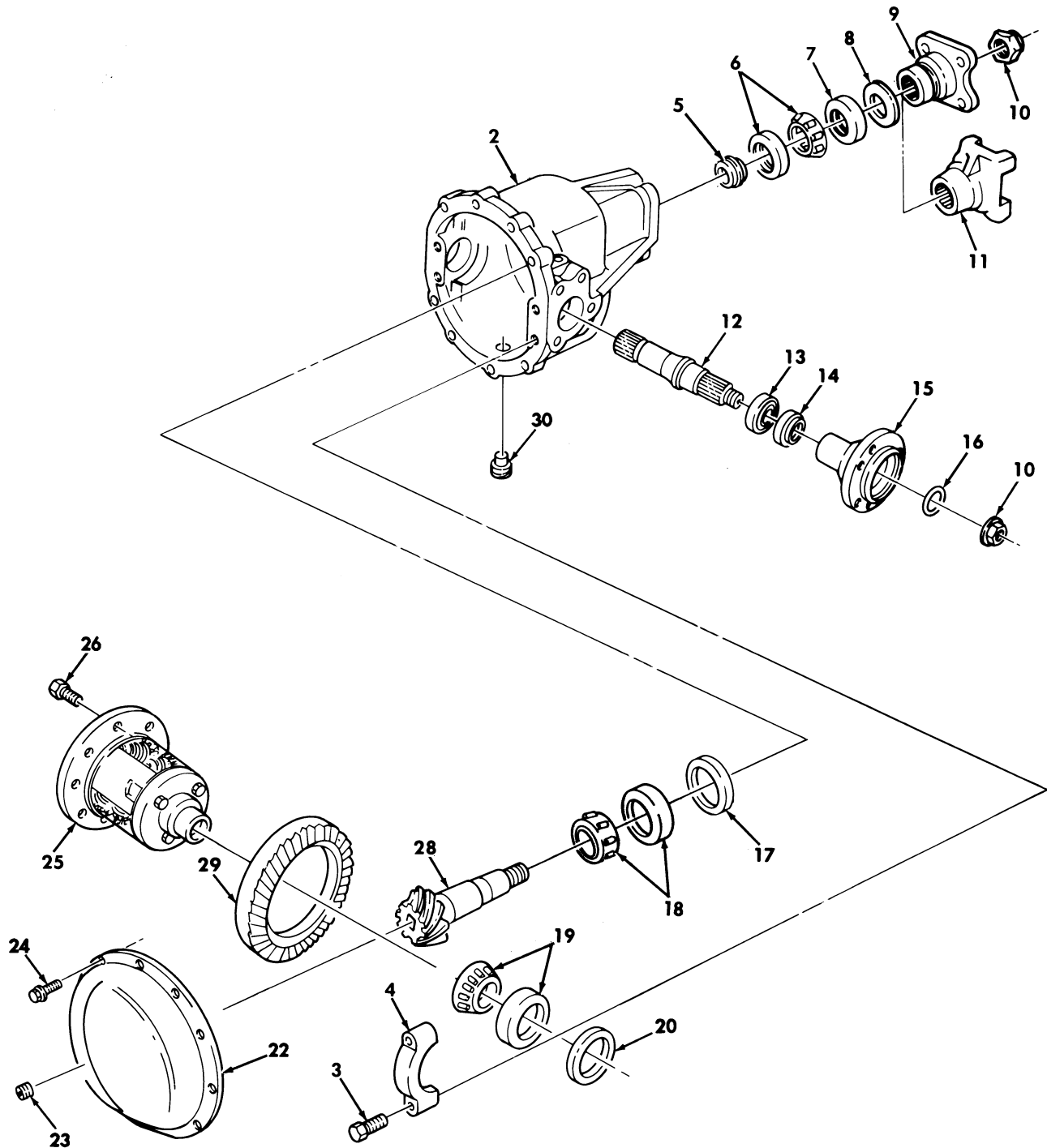
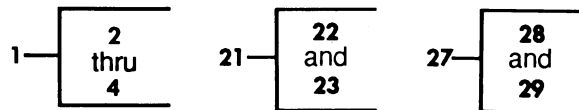

Figure 148. Axle Differential.

SECTION II			TM9-2320-280-24P			
(1)	(2)	(3)	(4)	(5)	(6)	(7)
ITEM NO	SMR CODE	NSN	CAGEC	PART NUMBER	DESCRIPTION AND USABLE ON CODES(UOC)	QTY
GROUP 1102 DIFFERENTIAL						
FIG. 148 AXLE DIFFERENTIAL						
1	PFHZZ	3040011749130	34623	5579424	HOUSING,MECHANICAL.....	1
2	XAHZZ		34623	5583758	.HOUSING.....	1
3	PAHZZ	5306012542358	34623	5595662	.BOLT,MACHINE 1/2-13 X 2.35.....	4
UOC:H15,H16,H17,H18,H20,H21,H24,H25,H26,H27,H28						
4	XAHZZ		34623	5579426	.CAP.....	2
5	PAHZZ	5365011802585	34623	5579450	SPACER,SLEEVE.....	1
6	PAHZZ	3110008541504	60038	M88048-M88010	BEARING,ROLLER,TAPE.....	2
7	PAFZZ	5330011748146	95019	41292	SEAL,PLAIN ENCASED.....	1
8	PAFZZ	2520012975200	34623	5598183	DEFLECTOR,DIRT AND USBL EFF 44825 AND ABOVE.....	1
9	PAFZZ	3010012926428	34623	5582968	FLANGE,COMPANION,UN USBL EFF 1 TO 44824.....	1
UOC:H11,H13,H14,H17,H18,H24,H25,H26,H27,MMM						
10	PAFZZ	5310011750617	34623	5579442	NUT,SELF-LOCKING,HE 7/8-14.....	3
11	PAFZZ	2520011885131	34623	5590551	YOKE,UNIVERSAL JOIN FRONT APPLICATION ONLY.....	1
11	PAFZZ	2520012677371	72447	2-4-6851-1	YOKE,UNIVERSAL JOIN USBL EFF 44825 AND ABOVE.....	1
12	PAHZZ	2520011749580	34623	5579991	SHAFT,AXLE,AUTOMOTI.....	1
13	PAHZZ	3110001556152	21335	P207K	BEARING,BALL,ANNULA.....	2
14	PAFZZ	5330011748145	34623	6009472	SEAL,PLAIN ENCASED.....	2
15	PAFZZ	2520011745849	34623	5593817	FLANGE,OUTPUT SHAFT.....	2
UOC:H15,H16,H17,H18,H20,H21,H24,H25,H26,H27,H28						
16	PAFZZ	5331010841200	34623	5939517	O-RING USED ON NEWER MODLES.....	1
17	PAHZZ	5365013814487	34623	5579445-54	SPACER,RING 0.1110-0.1120 PART OF KIT P/N 5579445.....	1
17	PAHZZ	5365013823676	34623	5579445-55	SPACER,RING 0.1099-0.1109 PART OF KIT P/N 5579445.....	1
17	PAHZZ	5365013820973	34623	5579445-56	SPACER,RING 0.1088-0.1098 PART OF KIT P/N 5579445.....	1
17	PAHZZ	5365013823710	34623	5579445-57	SPACER,RING 0.1077-0.1087 PART OF KIT P/N 5579445.....	1
17	PAHZZ	5365013821170	34623	5579445-58	SPACER,RING 0.1066-0.1076 PART OF KIT P/N 5579445.....	1
17	PAHZZ	5365013821235	34623	5579445-59	SPACER,RING 0.1055-0.1065 PART OF KIT P/N 5579445.....	1
17	PAHZZ	5365013821181	34623	5579445-60	SPACER,RING 0.1044-0.1054 PART OF KIT P/N 5579445.....	1
17	PAHZZ	5365013821135	34623	5579445-61	SPACER,RING 0.1033-0.1043 PART OF KIT P/N 5579445.....	1
17	PAHZZ	5365013821177	34623	5579445-62	SPACER,RING 0.1022-0.1032 PART OF KIT P/N 5579445.....	1
17	PAHZZ	5365013821162	34623	5579445-63	SPACER,RING 0.1011-0.1021 PART OF KIT P/N 5579445.....	1
17	PAHZZ	5365013823693	34623	5579445-64	SPACER,RING 0.1000-0.1010 PART OF KIT P/N 5579445.....	1



SECTION II		TM9-2320-280-24P					
(1)	(2)	(3)	(4)	(5)	(6)	(7)	
ITEM NO	SMR CODE	NSN	CAGEC	PART NUMBER	DESCRIPTION AND USABLE ON CODES(UOC)	QTY	
17	PAHZZ	5365013823726	34623	5579445-65	SPACER,RING 0.0989-0.0999 PART OF KIT P/N 5579445.....	1	
17	PAHZZ	5365013821273	34623	5579445-66	SPACER,RING 0.0978-0.0988 PART OF KIT P/N 5579445.....	1	
17	PAHZZ	5365013821166	34623	5579445-67	SPACER,RING 0.0967-0.0977 PART OF KIT P/N 5579445.....	1	
17	PAHZZ	5365013821157	34623	5579445-68	SPACER,RING 0.0956-0.0966 PART OF KIT P/N 5579445.....	1	
17	PAHZZ	5365013821240	34623	5579445-69	SPACER,RING 0.0945-0.0955 PART OF KIT P/N 5579445.....	1	
17	PAHZZ	5365013823718	34623	5579445-70	SPACER,RING 0.0934-0.0944 PART OF KIT P/N 5579445.....	1	
17	PAHZZ	5365013821132	34623	5579445-71	SPACER,RING 0.0923-0.0933 PART OF KIT P/N 5579445.....	1	
17	PAHZZ	5365013821171	34623	5579445-72	SPACER,RING 0.0912-0.0922 PART OF KIT P/N 5579445.....	1	
17	PAHZZ	5365013823715	34623	5579445-73	SPACER,RING 0.0901-0.0911 PART OF KIT P/N 5579445.....	1	
17	PAHZZ	5365013884449	34623	5579445-74	SPACER,RING 0.0890-0.0900 PART OF KIT P/N 5579445.....	1	
17	PAHZZ	5365013823694	34623	5579445-75	SPACER,RING 0.0879-0.0889 PART OF KIT P/N 5579445.....	1	
17	PAHZZ	5365013821159	34623	5579445-76	SPACER,RING 0.0868-0.0878 PART OF KIT P/N 5579445.....	1	
17	PAHZZ	5365013823447	34623	5579445-77	SPACER,RING 0.0857-0.0867 PART OF KIT P/N 5579445.....	1	
17	PAHZZ	5365013823700	34623	5579445-78	SPACER,RING 0.0846-0.0856 PART OF KIT P/N 5579445.....	1	
17	PAHZZ	5365013821058	34623	5579445-79	SPACER,RING 0.0835-0.0845 PART OF KIT P/N 5579445.....	1	
18	PAHZZ	3110004069608	60038	M802048M802011	BEARING,ROLLER,TAPE.....	1	
19	PAHZZ	3110008920896	60038	LM603049LM603012	BEARING,ROLLER,TAPE.....	2	
20	PAHZZ	5365013815166	34623	5579453-44	SPACER,RING 0.0745-0.0755 PART OF KIT P/N 5579453.....	1	
20	PAHZZ	5365013819582	34623	5579453-45	SPACER,RING 0.0756-0.0766 PART OF KIT P/N 5579453.....	1	
20	PAHZZ	5365013815174	34623	5579453-46	SPACER,RING 0.0767-0.0777 PART OF KIT P/N 5579453.....	1	
20	PAHZZ	5365013816332	34623	5579453-47	SPACER,RING 0.0778-0.0788 PART OF KIT P/N 5579453.....	1	
20	PAHZZ	5365013816120	34623	5579453-48	SPACER,RING 0.0789-0.0799 PART OF KIT P/N 5579453.....	1	
20	PAHZZ	5365013805345	34623	5579453-49	SPACER,RING 0.0800-0.0810 PART OF KIT P/N 5579453.....	1	
20	PAHZZ	5365013816151	34623	5579453-50	SPACER,RING 0.0811-0.0821 PART OF KIT P/N 5579453.....	1	
20	PAHZZ	5365013816276	34623	5579453-51	SPACER,RING 0.0822-0.0832 PART OF KIT P/N 5579453.....	1	
20	PAHZZ	5365013816223	34623	5579453-52	SPACER,RING 0.0833-0.0843 PART OF KIT P/N 5579453.....	1	
20	PAHZZ	5365013816080	34623	5579453-53	SPACER,RING 0.0844-0.0854 PART OF KIT P/N 5579453.....	1	
20	PAHZZ	5365013816250	34623	5579453-54	SPACER,RING 0.0855-0.0865 PART OF	1	

SECTION II			TM9-2320-280-24P			
(1)	(2)	(3)	(4)	(5)	(6)	(7)
ITEM	SMR			PART		
NO	CODE	NSN	CAGEC	NUMBER	DESCRIPTION AND USABLE ON CODES(UOC)	QTY
20	PAHZZ	5365013816145	34623	5579453-55	KIT P/N 5579453..... SPACER,RING 0.0866-0.0876 PART OF	1
20	PAHZZ	5365013816174	34623	5579453-56	KIT P/N 5579453..... SPACER,RING 0.0877-0.0887 PART OF	1
20	PAHZZ	5365013816210	34623	5579453-57	KIT P/N 5579453..... SPACER,RING 0.0888-0.0898 PART OF	1
20	PAHZZ	5365013816292	34623	5579453-58	KIT P/N 5579453..... SPACER,RING 0.0899-0.0909 PART OF	1
20	PAHZZ	5365013816110	34623	5579453-59	KIT P/N 5579453..... SPACER,RING 0.0910-0.0920 PART OF	1
20	PAHZZ	5365013816158	34623	5579453-60	KIT P/N 5579453..... SPACER,RING 0.0921-0.0931 PART OF	1
20	PAHZZ	5365013816313	34623	5579453-61	KIT P/N 5579453..... SPACER,RING 0.0932-0.0942 PART OF	1
20	PAHZZ	5365013816226	34623	5579453-62	KIT P/N 5579453..... SPACER,RING 0.0943-0.0953 PART OF	1
20	PAHZZ	5365013816076	34623	5579453-63	KIT P/N 5579453..... SPACER,RING 0.0954-0.0964 PART OF	1
20	PAHZZ	5365013816303	34623	5579453-64	KIT P/N 5579453..... SPACER,RING 0.0965-0.0975 PART OF	1
20	PAHZZ	5365013816164	34623	5579453-65	KIT P/N 5579453..... SPACER,RING 0.0976-.0.0986 PART OF	1
20	PAHZZ	5365013816197	34623	5579453-66	KIT P/N 5579453..... SPACER,RING 0.0987-0.0997 PART OF	1
20	PAHZZ	5365013816229	34623	5579453-67	KIT P/N 5579453..... SPACER,RING 0.0998-0.1008 PART OF	1
20	PAHZZ	5365013816086	34623	5579453-68	KIT P/N 5579453..... SPACER,RING 0.1009-0.1019 PART OF	1
20	PAHZZ	5365013816122	34623	5579453-69	KIT P/N 5579453..... SPACER,RING 0.1020-0.1030 PART OF	1
20	PAHZZ	5365013816154	34623	5579453-70	KIT P/N 5579453..... SPACER,RING 0.1031-0.1041 PART OF	1
20	PAHZZ	5365013816188	34623	5579453-71	KIT P/N 5579453..... SPACER,RING 0.1042-0.1052 PART OF	1
20	PAHZZ	5365013816317	34623	5579453-72	KIT P/N 5579453..... SPACER,RING 0.1053-0.1063 PART OF	1
20	PAHZZ	5365013816240	34623	5579453-73	KIT P/N 5579453..... SPACER,RING 0.1064-0.1074 PART OF	1
20	PAHZZ	5365013816112	34623	5579453-74	KIT P/N 5579453..... SPACER,RING 0.1075-0.1085 PART OF	1
20	PAHZZ	5365013816258	34623	5579453-75	KIT P/N 5579453..... SPACER,RING 0.1086-0.1096 PART OF	1
20	PAHZZ	5365013816165	34623	5579453-76	KIT P/N 5579453..... SPACER,RING 0.1097-0.1107 PART OF	1
20	PAHZZ	5365013816211	34623	5579453-77	KIT P/N 5579453..... SPACER,RING 0.1108-0.1118 PART OF	1
20	PAHZZ	5365013819588	34623	5579453-78	KIT P/N 5579453..... SPACER,RING 0.1119-0.1129 PART OF	1
20	PAHZZ	5365014381556	34623	5579453-79	KIT P/N 5579453..... SPACER,RING 0.1130-0.1140 PART OF	1
20	PAHZZ	5365013816113	34623	5579453-80	KIT P/N 5579453..... SPACER,RING 0.1141-0.1151 PART OF	1

SECTION II			TM9-2320-280-24P			
(1)	(2)	(3)	(4)	(5)	(6)	(7)
ITEM NO	SMR CODE	NSN	CAGEC	PART NUMBER	DESCRIPTION AND USABLE ON CODES(UOC)	QTY
20	PAHZZ	5365013816261	34623	5579453-81	SPACER,RING 0.1152-0.1162 PART OF KIT P/N 5579453.....	1
20	PAHZZ	5365013816175	34623	5579453-82	SPACER,RING 0.1163-0.1173 PART OF KIT P/N 5579453.....	1
20	PAHZZ	5365013816278	34623	5579453-83	SPACER,RING 0.1174-0.1184 PART OF KIT P/N 5579453.....	1
21	PAHZZ	2520012102624	34623	5582303	COVER,DIFFERENTIAL.....	1
22	XAHZZ		34623	5579436	.COVER 5/16-18 X 5/8.....	1
23	PAOZZ	4730012573348	34623	5597050	.PLUG,PIPE 1/2-14.....	1
24	PAHZZ	5305011748625	92871	5579438	SCREW,MACHINE.....	12
25	PAHZZ	2520013575056	34623	5936107	DIFFERENTIAL GEAR U.....	1
26	PAHZZ	5305006897472	80205	MS35308-384	SCREW,CAP,HEXAGON H 7/16-20 X 7/8..	8
27	PAHZZ	3020013643398	34623	5935390	GEAR SET,BEVEL,MATC..... UOC:AVY,A11,A13,A14,A15,A20,A24,A25, A26,A27,BVY,B15,B16,B17,B18,B20,B24, B25,C17,HVY,NNN	1
27	PAHZZ	3020011918784	34623	5579501	GEAR SET,BEVEL,MATC..... UOC:H11,H13,H14,H15,H16,H17,H18,H20, H21,H24,H25,H26,H27,H28,MMM	1
28	XAHZZ		34623	5935391	.PINION GEAR..... UOC:AVY,A11,A13,A14,A15,A20,A24,A25, A26,A27,BVY,B15,B16,B17,B18,B20,B24, B25,C17,HVY,NNN	1
28	XAHZZ		34623	5579435	.PINION GEAR..... UOC:H11,H13,H14,H15,H16,H17,H18,H20, H21,H24,H25,H26,H27,H28,MMM	1
29	XAHZZ		34623	5935392	.RING..... UOC:AVY,A11,A13,A14,A15,A20,A24,A25, A26,A27,BVY,B15,B16,B17,B18,B20,B24, B25,C17,HVY,NNN	1
29	XAHZZ		34623	5579428	.RING..... UOC:H11,H13,H14,H15,H16,H17,H18,H20, H21,H24,H25,H26,H27,H28,MMM	1
30	PAOZZ	4730011358310	58536	A-A-59432-08	PLUG,PIPE,MAGNETIC 1/8-27 X 3/8....	1

END OF FIGURE

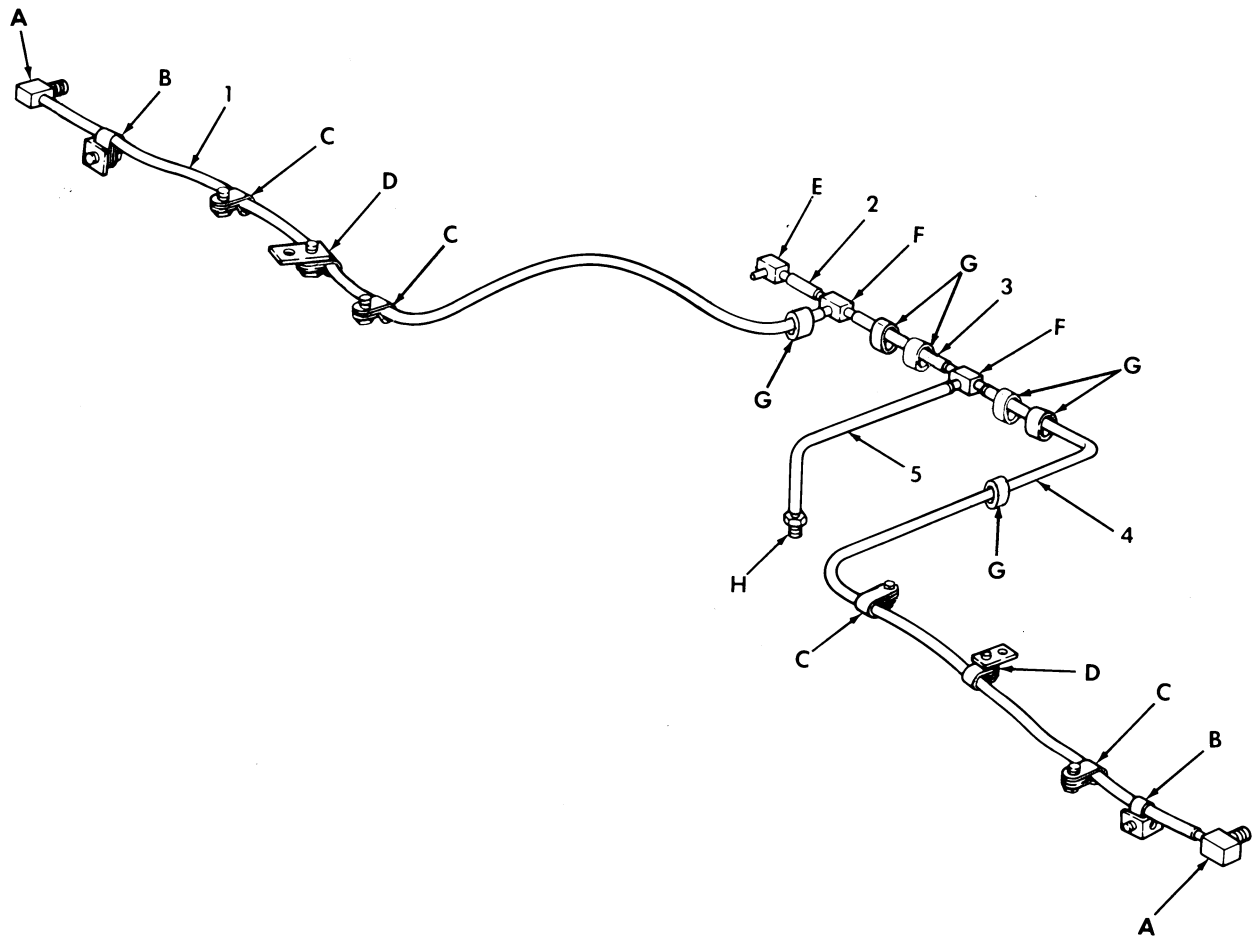



 <p>VIEW A</p>	 <p>VIEW B</p>	 <p>VIEW C</p>	 <p>VIEW D</p>
 <p>VIEW E</p>	 <p>VIEW F</p>	 <p>VIEW G</p>	 <p>VIEW H</p>

Figure 149. Rear Axle Differential and Geared Hub Vent Lines.

SECTION II			TM9-2320-280-24P			
(1)	(2)	(3)	(4)	(5)	(6)	(7)
ITEM	SMR			PART		
NO	CODE	NSN	CAGEC	NUMBER	DESCRIPTION AND USABLE ON CODES(UOC)	QTY
GROUP 1102 DIFFERENTIAL						
FIG. 149 REAR AXLE DIFFERENTIAL AND GEARED HUB VENT LINES						
1	MOOZZ		34623	5591158	TUBE R.H.,MAKE FROM TUBING,P/N CPR104420-1,35 INCHES LONG.....	1
2	MOOZZ		34623	5597262	TUBE MAKE FROM TUBING,P/N CPR104420-1,5 INCHES LONG.....	1
3	MOOZZ		34623	5591483	TUBE MAKE FROM TUBING,P/N CPR104420-1,7 INCHES LONG.....	1
4	MOOZZ		34623	5591157	TUBE L.H.,MAKE FROM TUBING,P/N CPR104420-1,42 INCHES LONG.....	1
5	MOOZZ		34623	5591161	TUBE MAKE FROM TUBING,P/N CPR104420-1,10 INCHES LONG.....	4
6	PAOZZ	4730010707680	34623	5582653	ELBOW,PIPE TO HOSE.....	2
7	PFOZZ	5340013003715	34623	5598208	BRACKET,ANGLE.....	2
8	PAOZZ	5340000509077	96906	MS21333-119	CLAMP,LOOP.....	8
9	PAOZZ	5305000518605	80205	MS16995-77	SCREW,CAP,SOCKET HE 3/8-16 X 1/2...	8
10	PFOZZ	5340012097767	19207	12338172	PLATE,MENDING.....	2
11	PAOZZ	4730010580900	79470	1065X4	ELBOW,HOSE.....	1
12	PAOZZ	4730010035105	79470	1064X4	TEE,HOSE.....	2
13	PAOZZ	5340012097808	08627	C3254	CLIP,SPRING TENSION REAR.....	6
14	PAOZZ	4730011855348	01989	1068X4	ADAPTER,STRAIGHT,PI.....	1

END OF FIGURE

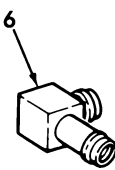
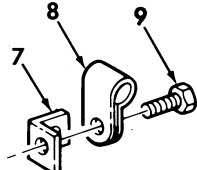
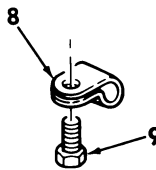
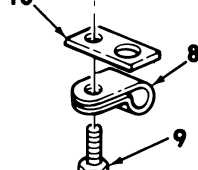
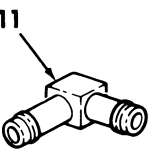
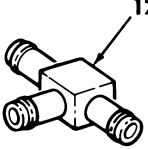
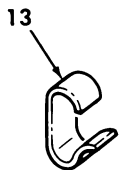
**USE WITH BASIC AND A1 VEHICLES**

1 — 2 thru 33

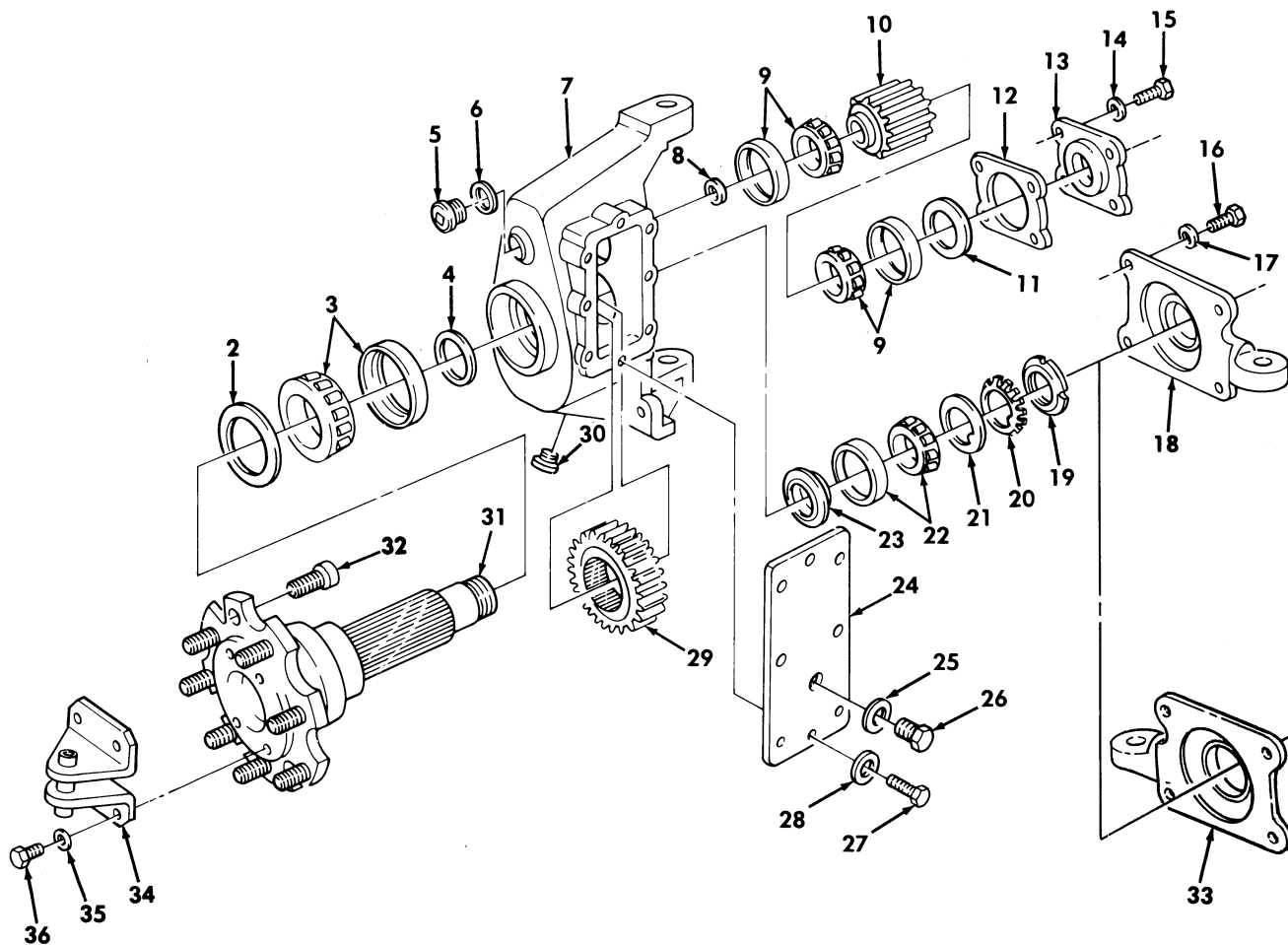

Figure 150. Rear Knuckle and Geared Hub Assembly.

SECTION II			TM9-2320-280-24P			
(1)	(2)	(3)	(4)	(5)	(6)	(7)
ITEM NO	SMR CODE	NSN	CAGEC	PART NUMBER	DESCRIPTION AND USABLE ON CODES(UOC)	QTY
					GROUP 1104 STEERING, SIDESHIFT AND WHEEL LEANING MECHANISM	
					FIG. 150 REAR KNUCKLE AND GEARED HUB ASSEMBLY	
1	PAOFF	2530012035746	34623	5598767	SPINDLE, WHEEL, DRIVE REAR..... UOC:AVY, A11, A13, A14, A15, A20, A24, A25, A26, A27, B16, B17, B18, HVY, H11, H13, H14, H15, H16, H17, H18, H20, H21, H24, H25, H26, H27, H28, MMM	2
2	PAOZZ	5330012036551	63769	CR 535094-60	.SEAL, NONMETALLIC SP..... UOC:AVY, A11, A13, A14, A15, A20, A24, A25, A26, A27, B16, B17, B18, HVY, H11, H13, H14, H15, H16, H17, H18, H20, H21, H24, H25, H26, H27, H28, MMM	1
3	PAFZZ	3110001005937	96906	MS19081-86	.BEARING, ROLLER, TAPE..... UOC:AVY, A11, A13, A14, A15, A20, A24, A25, A26, A27, B16, B17, B18, HVY, H11, H13, H14, H15, H16, H17, H18, H20, H21, H24, H25, H26, H27, H28, MMM	1
4	PAFZZ	5365011748186	34623	5573989	.SPACER, RING OUTER..... UOC:AVY, A11, A13, A14, A15, A20, A24, A25, A26, A27, B16, B17, B18, HVY, H11, H13, H14, H15, H16, H17, H18, H20, H21, H24, H25, H26, H27, H28, MMM	1
5	PAOZZ	4730012476763	34623	5595214	.PLUG, PIPE UPPER..... UOC:AVY, A11, A13, A14, A15, A20, A24, A25, A26, A27, B16, B17, B18, HVY, H11, H13, H14, H15, H16, H17, H18, H20, H21, H24, H25, H26, H27, H28, MMM	1
6	PAOZZ	5310012310596	34623	5573688	.WASHER, LOCK UPPER..... UOC:AVY, A11, A13, A14, A15, A20, A24, A25, A26, A27, B16, B17, B18, HVY, H11, H13, H14, H15, H16, H17, H18, H20, H21, H24, H25, H26, H27, H28, MMM	1
7	XAFFF		34623	5593993	.KNUCKLE AND GEAR..... UOC:AVY, A11, A13, A14, A15, A20, A24, A25, A26, A27, B16, B17, B18, HVY, H11, H13, H14, H15, H16, H17, H18, H20, H21, H24, H25, H26, H27, H28, MMM	1
8	PAFZZ	5310011748632	34623	5568223	.WASHER, FLAT 1-1/4..... UOC:AVY, A11, A13, A14, A15, A20, A24, A25, A26, A27, B16, B17, B18, HVY, H11, H13, H14, H15, H16, H17, H18, H20, H21, H24, H25, H26, H27, H28, MMM	1
9	PAFZZ	3110010274475	34623	5568226	.BEARING, ROLLER, TAPE UPPER..... UOC:AVY, A11, A13, A14, A15, A20, A24, A25, A26, A27, B16, B17, B18, HVY, H11, H13, H14, H15, H16, H17, H18, H20, H21, H24, H25, H26, H27, H28, MMM	2
10	PAFZZ	3020011745985	34623	5574921	.GEAR, SPUR UPPER..... UOC:AVY, A11, A13, A14, A15, A20, A24, A25,	1

SECTION II			TM9-2320-280-24P			
(1)	(2)	(3)	(4)	(5)	(6)	(7)
ITEM NO	SMR CODE	NSN	CAGEC	PART NUMBER	DESCRIPTION AND USABLE ON CODES(UOC)	QTY
11	PAOZZ	5330011809099	73680	2994-2106	A26,A27,B16,B17,B18,HVY,H11,H13,H14,H15,H16,H17,H18,H20,H21,H24,H25,H26,H27,H28,MMM .SEAL,PLAIN UPPER..... UOC:AVY,A11,A13,A14,A15,A20,A24,A25,A26,A27,B16,B17,B18,HVY,H11,H13,H14,H15,H16,H17,H18,H20,H21,H24,H25,H26,H27,H28,MMM	1
12	PAOZZ	5330011760825	34623	5573692	.GASKET SHIM 0.005..... UOC:AVY,A11,A13,A14,A15,A20,A24,A25,A26,A27,B16,B17,B18,HVY,H11,H13,H14,H15,H16,H17,H18,H20,H21,H24,H25,H26,H27,H28,MMM	V
13	PAOZZ	5340011748493	34623	5574002	.RETAINER UPPER..... UOC:AVY,A11,A13,A14,A15,A20,A24,A25,A26,A27,B16,B17,B18,HVY,H11,H13,H14,H15,H16,H17,H18,H20,H21,H24,H25,H26,H27,H28,MMM	1
14	PAOZZ	5310000806004	96906	MS27183-14	.WASHER,FLAT UPPER,3/8..... UOC:AVY,A11,A13,A14,A15,A20,A24,A25,A26,A27,B16,B17,B18,HVY,H11,H13,H14,H15,H16,H17,H18,H20,H21,H24,H25,H26,H27,H28,MMM	4
15	PAOZZ	5305000680510	80204	B1821BH038C100N	.SCREW,CAP,HEXAGON H UPPER,3/8-16 X 1.00..... UOC:AVY,A11,A13,A14,A15,A20,A24,A25,A26,A27,B16,B17,B18,HVY,H11,H13,H14,H15,H16,H17,H18,H20,H21,H24,H25,H26,H27,H28,MMM	4
16	PAOZZ	5305000712067	80204	B1821BH050C125N	.SCREW,CAP,HEXAGON H 1/2-13 X 1.25. UOC:AVY,A11,A13,A14,A15,A20,A24,A25,A26,A27,B16,B17,B18,HVY,H11,H13,H14,H15,H16,H17,H18,H20,H21,H24,H25,H26,H27,H28,MMM	4
17	PAOZZ	53100008095998	96906	MS27183-18	.WASHER,FLAT 1/2..... UOC:AVY,A11,A13,A14,A15,A20,A24,A25,A26,A27,B16,B17,B18,HVY,H11,H13,H14,H15,H16,H17,H18,H20,H21,H24,H25,H26,H27,H28,MMM	4
18	PAOZZ	2530012035662	34623	5591280	.COVER,STEERING ARM R.H..... UOC:AVY,A11,A13,A14,A15,A20,A24,A25,A26,A27,B16,B17,B18,HVY,H11,H13,H14,H15,H16,H17,H18,H20,H21,H24,H25,H26,H27,H28,MMM	1
19	PAOZZ	5310013825031	19207	12342680	.NUT,PLAIN,ROUND 1-3/8..... UOC:AVY,A11,A13,A14,A15,A20,A24,A25,A26,A27,B16,B17,B18,HVY,H11,H13,H14,H15,H16,H17,H18,H20,H21,H24,H25,H26,H27,H28,MMM	1
20	PAOZZ	5310012134185	34623	5584462	.WASHER,KEY 1-3/8..... UOC:AVY,A11,A13,A14,A15,A20,A24,A25,A26,A27,B16,B17,B18,HVY,H11,H13,H14,H15,H16,H17,H18,H20,H21,H24,H25,H26,H27,H28,MMM	1



SECTION II			TM9-2320-280-24P			
(1)	(2)	(3)	(4)	(5)	(6)	(7)
ITEM NO	SMR CODE	NSN	CAGEC	PART NUMBER	DESCRIPTION AND USABLE ON CODES(UOC)	QTY
21	PAOZZ	5310011748607	34623	5573684	H27, H28, MMM .WASHER, KEY 1-3/8.....	1
					UOC:AVY, A11, A13, A14, A15, A20, A24, A25, A26, A27, B16, B17, B18, HVY, H11, H13, H14, H15, H16, H17, H18, H20, H21, H24, H25, H26, H27, H28, MMM	
22	PAFZZ	3110001005920	55509	BM2337	.BEARING, ROLLER, TAPE INNER.....	1
					UOC:AVY, A11, A13, A14, A15, A20, A24, A25, A26, A27, B16, B17, B18, HVY, H11, H13, H14, H15, H16, H17, H18, H20, H21, H24, H25, H26, H27, H28, MMM	
23	PAFZZ	5365011815085	34623	5584137	.SPACER, SLEEVE.....	1
					UOC:AVY, A11, A13, A14, A15, A20, A24, A25, A26, A27, B16, B17, B18, HVY, H11, H13, H14, H15, H16, H17, H18, H20, H21, H24, H25, H26, H27, H28, MMM	
24	PAFZZ	5340011742271	34623	5574924	.COVER, ACCESS.....	1
					UOC:AVY, A11, A13, A14, A15, A20, A24, A25, A26, A27, B16, B17, B18, HVY, H11, H13, H14, H15, H16, H17, H18, H20, H21, H24, H25, H26, H27, H28, MMM	
25	PAOZZ	5310011760839	34623	5573687	.WASHER, FLAT.....	1
					UOC:AVY, A11, A13, A14, A15, A20, A24, A25, A26, A27, B16, B17, B18, HVY, H11, H13, H14, H15, H16, H17, H18, H20, H21, H24, H25, H26, H27, H28, MMM	
26	PAOZZ	5365011775720	34623	5573690	.PLUG, MACHINE THREAD.....	1
					UOC:AVY, A11, A13, A14, A15, A20, A24, A25, A26, A27, B16, B17, B18, HVY, H11, H13, H14, H15, H16, H17, H18, H20, H21, H24, H25, H26, H27, H28, MMM	
27	PAFZZ	5306011973274	7X677	9419343	.BOLT, ASSEMBLED WASH 5/16-18 X 5/8.	8
					UOC:AVY, A11, A13, A14, A15, A20, A24, A25, A26, A27, B16, B17, B18, HVY, H11, H13, H14, H15, H16, H17, H18, H20, H21, H24, H25, H26, H27, H28, MMM	
28	PAFZZ	5310000814219	96906	MS27183-12	.WASHER, FLAT 5/16.....	8
					UOC:AVY, A11, A13, A14, A15, A20, A24, A25, A26, A27, B16, B17, B18, HVY, H11, H13, H14, H15, H16, H17, H18, H20, H21, H24, H25, H26, H27, H28, MMM	
29	PAFZZ	3020011745984	19207	12338723	.GEAR, SPUR LOWER.....	1
					UOC:AVY, A11, A13, A14, A15, A20, A24, A25, A26, A27, B16, B17, B18, HVY, H11, H13, H14, H15, H16, H17, H18, H20, H21, H24, H25, H26, H27, H28, MMM	
30	PAOZZ	4730000459769	96906	MS49006-6	.PLUG, PIPE, MAGNETIC.....	1
					UOC:AVY, A11, A13, A14, A15, A20, A24, A25, A26, A27, B16, B17, B18, HVY, H11, H13, H14, H15, H16, H17, H18, H20, H21, H24, H25, H26, H27, H28, MMM	
31	PAFZZ	2530011744174	34623	5579061	.SPINDLE, WHEEL, DRIVI.....	1
					UOC:AVY, A11, A13, A14, A15, A20, A24, A25,	

SECTION II			TM9-2320-280-24P			
(1)	(2)	(3)	(4)	(5)	(6)	(7)
ITEM	SMR			PART		
NO	CODE	NSN	CAGEC	NUMBER	DESCRIPTION AND USABLE ON CODES(UOC)	QTY
32	PAOZZ	5307011964937	34623	5568211	A26,A27,B16,B17,B18,HVY,H11,H13,H14, H15,H16,H17,H18,H20,H21,H24,H25,H26, H27,H28,MMM .STUD,SELF-LOCKING 9/16-18 X 1.50..	8
					UOC:AVY,A11,A13,A14,A15,A20,A24,A25, A26,A27,B16,B17,B18,HVY,H11,H13,H14, H15,H16,H17,H18,H20,H21,H24,H25,H26, H27,H28,MMM	
33	PAOZZ	2530012035663	34623	5591279	.COVER,STEERING ARM L.H.....	1
					UOC:AVY,A11,A13,A14,A15,A20,A24,A25, A26,A27,B16,B17,B18,HVY,H11,H13,H14, H15,H16,H17,H18,H20,H21,H24,H25,H26, H27,H28,MMM	
34	PAOZZ	5340011634773	19207	12338324	BRACKET,MOUNTING.....	2
					UOC:AVY,A11,A13,A14,A15,A20,A24,A25, A26,A27,B16,B17,B18,HVY,H11,H13,H14, H15,H16,H17,H18,H20,H21,H24,H25,H26, H27,H28,MMM	
35	PAOZZ	5310002090965	96906	MS35338-47	WASHER,LOCK 7/16.....	8
					UOC:AVY,A11,A13,A14,A15,A20,A24,A25, A26,A27,B16,B17,B18,HVY,H11,H13,H14, H15,H16,H17,H18,H20,H21,H24,H25,H26, H27,H28,MMM	
36	PAOZZ	5306012531611	96906	MS35764-848	BOLT,SELF-LOCKING 7/16-13 X 1.50...	8
					UOC:AVY,A11,A13,A14,A15,A20,A24,A25, A26,A27,B16,B17,B18,HVY,H11,H13,H14, H15,H16,H17,H18,H20,H21,H24,H25,H26, H27,H28,MMM	

END OF FIGURE

Section II.

TM 9-2320-280-24P-1

USE WITH A2 VEHICLES

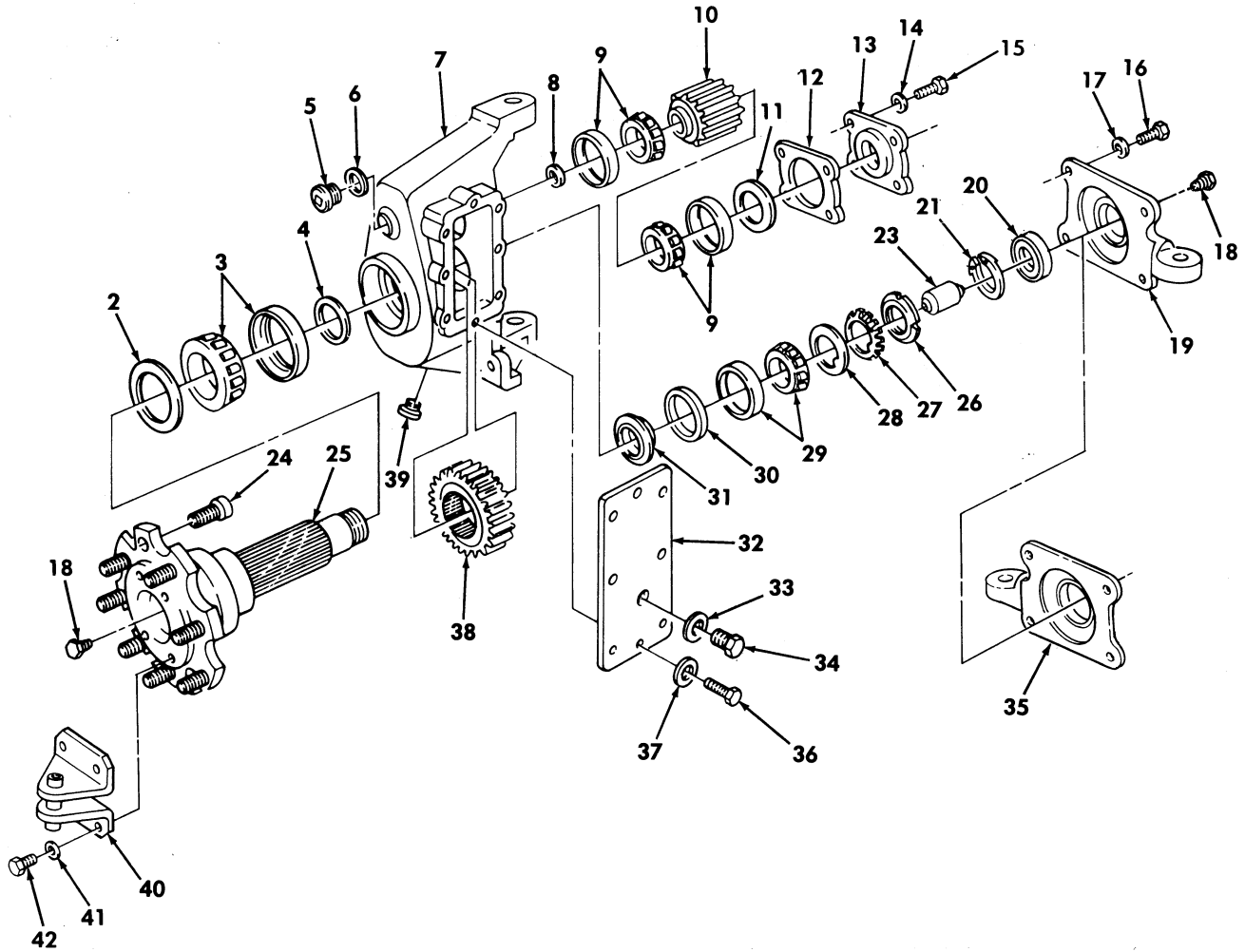
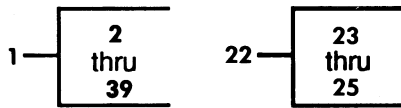

Figure 151. Rear Knuckle and Geared Hub Assembly.

SECTION II			TM9-2320-280-24P			
(1)	(2)	(3)	(4)	(5)	(6)	(7)
ITEM	SMR			PART		
NO	CODE	NSN	CAGEC	NUMBER	DESCRIPTION AND USABLE ON CODES(UOC)	QTY
GROUP 1104 STEERING, SIDESHIFT AND WHEEL LEANING MECHANISM						
FIG. 151 REAR KNUCKLE AND GEARED HUB ASSEMBLY						
1	PAOFF	2530014133653	34623	6009352	SPINDLE, WHEEL, DRIV L.H., FOR R.H. REPLACE ITEM 19 WITH ITEM 35..... UOC: BVY, B15, B20, B24, B25, C17, NNN	2
2	PAOZZ	5330012036551	63769	CR 535094-60	. SEAL, PLAIN ENCASED..... UOC: BVY, B15, B20, B24, B25, C17, NNN	1
3	PAFZZ	3110001005937	96906	MS19081-86	. BEARING, ROLLER, TAPE..... UOC: BVY, B15, B20, B24, B25, C17, NNN	1
4	PAFZZ	5365011748186	34623	5573989	. SPACER, RING OUTER..... UOC: BVY, B15, B20, B24, B25, C17, NNN	1
5	PAOZZ	5365000777341	24617	453006	. PLUG, PIPE UPPER..... UOC: BVY, B15, B20, B24, B25, C17, NNN	1
6	PAOZZ	5310012310596	34623	5573688	. WASHER, LOCK UPPER..... UOC: BVY, B15, B20, B24, B25, C17, NNN	1
7	XAFFF		34623	5593993	. KNUCKLE AND GEAR..... UOC: BVY, B15, B20, B24, B25, C17, NNN	1
8	PAFZZ	5310014733373	34623	6009454	. SPACER, SLEEVE..... UOC: BVY, B15, B20, B24, B25, C17, NNN	1
9	PAFZZ	3110010274475	34623	5568226	. BEARING, ROLLER, TAPE UPPER..... UOC: BVY, B15, B20, B24, B25, C17, NNN	2
10	PAFZZ	3020014322553	34623	6009453	. GEAR, SPUR UPPER..... UOC: BVY, B15, B20, B24, B25, C17, NNN	1
11	PAOZZ	5330011809099	73680	2994-2106	. SEAL, PLAIN UPPER..... UOC: BVY, B15, B20, B24, B25, C17, NNN	1
12	PAOZZ	5330011760825	34623	5573692	. GASKET 0.005..... UOC: BVY, B15, B20, B24, B25, C17, NNN	V
13	PAOZZ	5340011748493	34623	5574002	. RETAINER..... UOC: BVY, B15, B20, B24, B25, C17, NNN	1
14	PAOZZ	5310000806004	96906	MS27183-14	. WASHER, FLAT UPPER, 3/8..... UOC: BVY, B15, B20, B24, B25, C17, NNN	4
15	PAOZZ	5305000680510	80204	B1821BH038C100N	. SCREW, CAP, HEXAGON H UPPER, 3/8-16 X 1.00..... UOC: BVY, B15, B20, B24, B25, C17, NNN	4
16	PAOZZ	5305000712067	80204	B1821BH050C125N	. SCREW, CAP, HEXAGON H 1/2-13 X 1.25. UOC: BVY, B15, B20, B24, B25, C17, NNN	4
17	PAOZZ	5310008095998	96906	MS27183-18	. WASHER, FLAT .1/2..... UOC: BVY, B15, B20, B24, B25, C17, NNN	4
18	PAOZZ	4730000127951	93334	127951	. PLUG, PIPE..... UOC: BVY, B15, B20, B24, B25, C17, NNN	2
19	PAOZZ	2530014338003	34623	6005120	. COVER, STEERING ARM L.H..... UOC: BVY, B15, B20, B24, B25, C17, NNN	1
20	PAOZZ	5330014568823	34623	6005193	. SEAL, PLAIN ENCASED..... UOC: BVY, B15, B20, B24, B25, C17, NNN	1
21	PAOZZ	5325005141299	79136	5008-125MD	. RING, RETAINING..... UOC: BVY, B15, B20, B24, B25, C17, NNN	1
22	PAOZZ	2530014492495	34623	5715160	. SPINDLE, WHEEL, DRIV..... UOC: BVY, B15, B20, B24, B25, C17, NNN	1
23	PAOZZ	5365014142902	34623	5594531	. SPACER, SLEEVE.....	1

SECTION II			TM9-2320-280-24P			
(1)	(2)	(3)	(4)	(5)	(6)	(7)
ITEM	SMR			PART		
NO	CODE	NSN	CAGEC	NUMBER	DESCRIPTION AND USABLE ON CODES(UC)	QTY
24	PAOZZ	5307011964937	34623	5568211	UC:BVY,B15,B20,B24,B25,C17,NNN .STUD,SELF-LOCKING 9/16-18 X 1.50.	8
25	XAOZZ		34623	6009349	UC:BVY,B15,B20,B24,B25,C17,NNN .SPINDLE,WHEEL,DRIVI.....	1
26	PAOZZ	5310013825031	19207	12342680	UC:BVY,B15,B20,B24,B25,C17,NNN .LOCKING,SPINDLE.....	1
27	PAOZZ	5310012134185	34623	5584462	UC:BVY,B15,B20,B24,B25,C17,NNN .WASHER,KEY 1-3/8.....	1
28	PAOZZ	5310011748607	34623	5573684	UC:BVY,B15,B20,B24,B25,C17,NNN .WASHER,KEY 1-3/8.....	1
29	PAOZZ	3110001005920	34623	5568227	UC:BVY,B15,B20,B24,B25,C17,NNN .BEARING,ROLLER,TAPE.....	1
30	PAOZZ	5365014562032	34623	6001784	UC:BVY,B15,B20,B24,B25,C17,NNN .SPACER,RING.....	1
31	PAOZZ	5365014142895	34623	06009350	UC:BVY,B15,B20,B24,B25,C17,NNN .SPACER,SLEEVE.....	1
32	PAOZZ	5340011742271	34623	5574924	UC:BVY,B15,B20,B24,B25,C17,NNN .COVER,ACCESS.....	1
33	PAOZZ	5310011760839	34623	5573687	UC:BVY,B15,B20,B24,B25,C17,NNN .WASHER,FLAT.....	1
34	PAOZZ	5365011775720	34623	5573690	UC:BVY,B15,B20,B24,B25,C17,NNN .PLUG,MACHINE THREAD.....	1
35	PAOZZ	2530014338702	34623	6005121	UC:BVY,B15,B20,B24,B25,C17,NNN .COVER,STEERING R.H.....	1
36	PAOZZ	5306002264823	80204	B1821BH031C056N	UC:BVY,B15,B20,B24,B25,C17,NNN .BOLT,ASSEMBLED WASH 5/16-18 X 5/8.	8
37	PAOZZ	5310000814219	96906	MS27183-12	UC:BVY,B15,B20,B24,B25,C17,NNN .WASHER,FLAT 5/16.....	8
38	PAFZZ	3020014762701	34623	6009452	UC:BVY,B15,B20,B24,B25,C17,NNN .GEAR,SPUR LOWER.....	1
39	PAOZZ	4730000459769	96906	MS49006-6	UC:BVY,B15,B20,B24,B25,C17,NNN .PIPE,PLUG,MAGNETIC.....	1
40	PAOZZ	5340011634773	19207	12338324	UC:BVY,B15,B20,B24,B25,C17,NNN BRACKET,MOUNTING.....	1
41	PAOZZ	5310002090965	96906	MS35338-47	UC:BVY,B15,B20,B24,B25,C17,NNN WASHER,LOCK..7/16.....	8
42	PAOZZ	5305000711786	80204	B1821BH044C100N	UC:BVY,B15,B20,B24,B25,C17,NNN SCREW,CAP,HEXAGON H 7/16-13 X 1.50.	8

END OF FIGURE

Section II.

TM 9-2320-280-24P-1

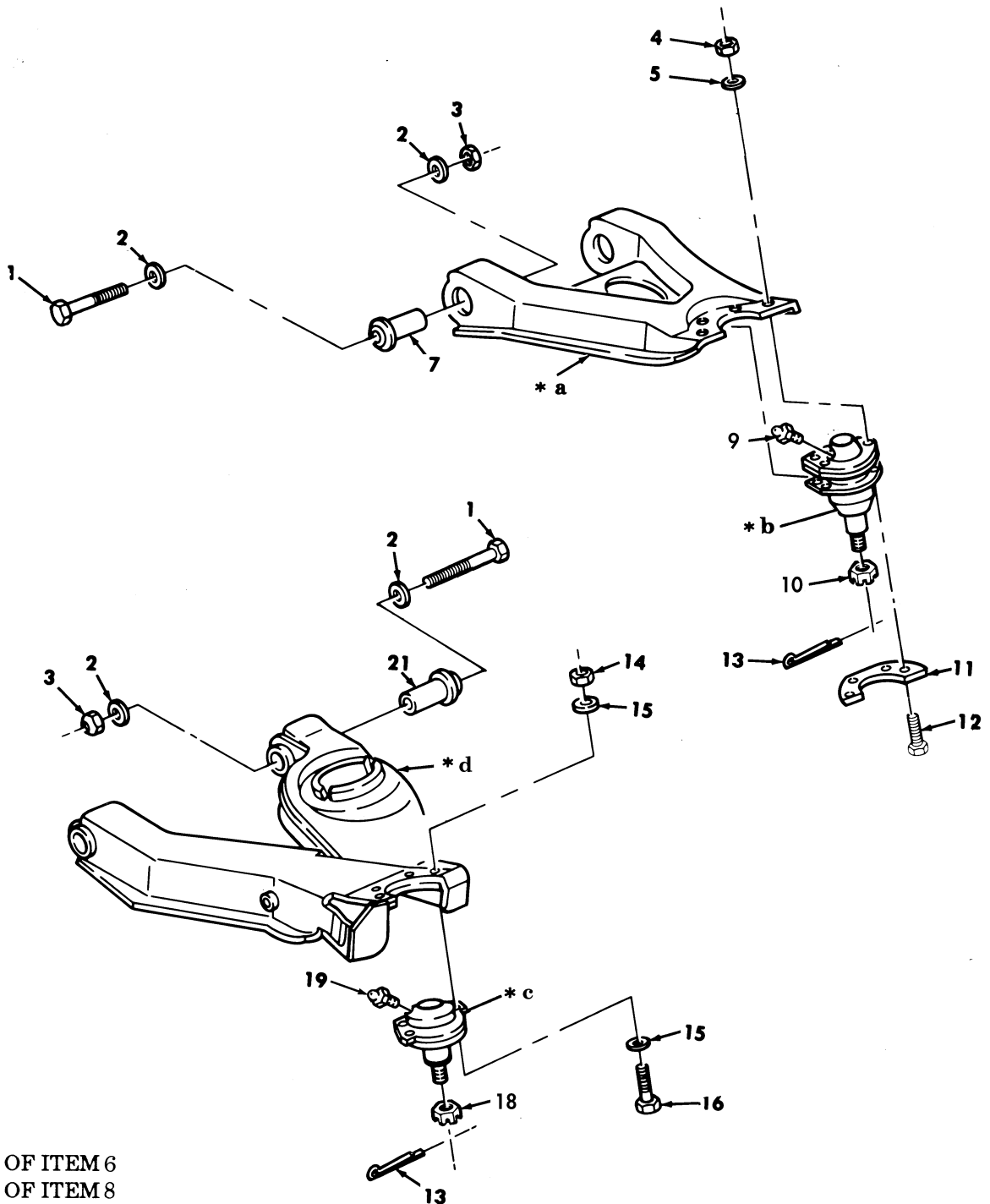
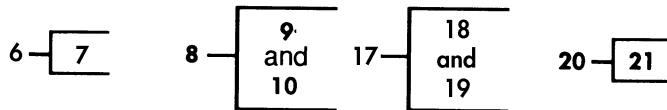

- \* a PART OF ITEM 6
- \* b PART OF ITEM 8
- \* c PART OF ITEM 17
- \* d PART OF ITEM 20

Figure 152. Rear Control Arms, Ball Joints, and Mounting Hardware.

SECTION II			TM9-2320-280-24P			
(1)	(2)	(3)	(4)	(5)	(6)	(7)
ITEM NO	SMR CODE	NSN	CAGEC	PART NUMBER	DESCRIPTION AND USABLE ON CODES(UOC)	QTY
GROUP 1104 STEERING, SIDESHIFT AND WHEEL LEANING MECHANISM						
FIG. 152 REAR CONTROL ARMS, BALL JOINTS, AND MOUNTING HARDWARE						
1	PAOZZ	5305009474361	80204	B1821BH075C475N	SCREW, CAP, HEXAGON H 3/4-10 X 4.75..	8
2	PAOZZ	5310011474052	23862	2436168	WASHER, FLAT 3/4.....	16
3	PAOZZ	5310004093333	96906	MS51943-45	NUT, SELF-LOCKING, HE 3/4-10.....	8
4	PAOZZ	5310008140673	96906	MS51943-33	NUT, SELF-LOCKING, HE UPPER, 5/16-18..	8
UOC: AVY, A11, A13, A14, A15, A20, A24, A25, A26, A27, B16, B17, B18, HVY, H11, H13, H14, H15, H16, H17, H18, H20, H21, H24, H25, H26, H27, H28, MMM						
4	PAOZZ	5310008140672	96906	MS51943-36	NUT, SELF-LOCKING, HE 3/8-24.....	8
UOC: BVY, B15, B20, B24, B25, C17, NNN						
5	PAOZZ	5310011191024	24617	2436162	WASHER, FLAT UPPER, 5/16.....	8
UOC: AVY, A11, A13, A14, A15, A20, A24, A25, A26, A27, B16, B17, B18, HVY, H11, H13, H14, H15, H16, H17, H18, H20, H21, H24, H25, H26, H27, H28, MMM						
5	PAOZZ	5310014124013	24617	2436163	WASHER, FLAT UPPER, 3/8.....	8
UOC: BVY, B15, B20, B24, B25, C17, NNN						
6	PAOFF	2530011764649	34623	5578822	ARM, UPPER CONTROL REAR, L.H.....	1
UOC: AVY, A11, A13, A14, A15, A20, A24, A25, A26, A27, B16, B17, B18, HVY, H11, H13, H14, H15, H16, H17, H18, H20, H21, H24, H25, H26, H27, H28, MMM						
6	PAOFF	2530011757210	34623	5578823	ARM, CONTROL, VEHICUL REAR, R.H.....	1
UOC: AVY, A11, A13, A14, A15, A20, A24, A25, A26, A27, B16, B17, B18, HVY, H11, H13, H14, H15, H16, H17, H18, H20, H21, H24, H25, H26, H27, H28, MMM						
6	PAOFF	2530014207893	34623	RCSK17089-2	ARM, CONTROL, VEHICUL REAR, R.H.....	1
UOC: BVY, B15, B20, B24, B25, C17, NNN						
6	PAOFF	2530014207892	34623	RCSK17089-1	ARM, CONTROL, VEHICUL REAR, L.H.....	1
UOC: BVY, B15, B20, B24, B25, C17, NNN						
7	PAFZZ	3120011865527	19207	12338270	. BUSHING, SLEEVE.....	2
8	PAOZZ	2530011883685	98349	C-205-TEZ-35	PARTS KIT, BALL JOIN UPPER, REAR.....	2
UOC: AVY, A11, A13, A14, A15, A20, A24, A25, A26, A27, B16, B17, B18, HVY, H11, H13, H14, H15, H16, H17, H18, H20, H21, H24, H25, H26, H27, H28, MMM						
8	PAOZZ	2530014131366	34623	6007755	PARTS KIT, BALL JOIN UPPER, REAR.....	2
UOC: BVY, B15, B20, B24, B25, C17, NNN						
9	PAOZZ	4730000504203	96906	MS15001-1	. FITTING, LUBRICATION.....	1
10	PAOZZ	5310008507004	96906	MS35692-54	. NUT, PLAIN, SLOTTED, H.....	1
11	PAOZZ	2530012101324	19207	12338320	RETAINER, BALL JOINT UPPER.....	2
UOC: AVY, A11, A13, A14, A15, A20, A24, A25, A26, A27, B16, B17, B18, HVY, H11, H13, H14, H15, H16, H17, H18, H20, H21, H24, H25, H26, H27, H28, MMM						
12	PAOZZ	5306002264829	80204	B1821BH031C125N	BOLT, MACHINE 5/16-18 X 1.25.....	8

SECTION II			TM9-2320-280-24P			
(1)	(2)	(3)	(4)	(5)	(6)	(7)
ITEM NO	SMR CODE	NSN	CAGEC	PART NUMBER	DESCRIPTION AND USABLE ON CODES(UC)	QTY
					UOC:AVY,A11,A13,A14,A15,A20,A24,A25,A26,A27,B16,B17,B18,HVY,H11,H13,H14,H15,H16,H17,H18,H20,H21,H24,H25,H26,H27,H28,MMM	
12	PAOZZ	5305014125994	19207	12460159	SCREW,CAP,HEXAGON H 3/8-24.....	8
					UOC:BVY,B15,B20,B24,B25,C17,NNN	
13	PAOZZ	5315000120123	80205	MS24665-355	PIN,COTTER.....	4
14	PAOZZ	5310009359021	96906	MS51943-35	NUT,SELF-LOCKING,HE LOWER,3/8-16...	8
					UOC:H11,H13,H14,H17,H18,H20,H24,H25,H26,H27,MMM	
14	PAOZZ	5310011504003	24617	9422299	NUT,SELF-LOCKING,HE 7/16-14.....	8
					UOC:AVY,A11,A13,A14,A15,A20,A24,A25,A26,A27,BVY,B15,B16,B17,B18,B20,B24,B25,C17,HVY,H15,H16,H21,H28,NNN	
15	PAOZZ	5310008094085	24617	2436164	WASHER,FLAT 7/16.....	16
					UOC:AVY,A11,A13,A14,A15,A20,A24,A25,A26,A27,BVY,B15,B16,B17,B18,B20,B24,B25,C17,HVY,H15,H16,H21,H28,NNN	
15	PAOZZ	5310014124013	24617	2436163	WASHER,FLAT 3/8.....	16
					UOC:H11,H13,H14,H17,H18,H20,H21,H24,H25,H26,H27,MMM	
16	PAOZZ	5305006882111	80204	B1821BH038C138N	SCREW,CAP,HEXAGON H 3/8-16 X 1.375.	8
					UOC:H11,H13,H14,H17,H18,H20,H21,H24,H25,H26,H27,MMM	
16	PAOZZ	5305000712055	80204	B1821BH044C150N	SCREW,CAP,HEXAGON H 7/16-14 X 1.50.	8
					UOC:AVY,A11,A13,A14,A15,A20,A24,A25,A26,A27,BVY,B15,B16,B17,B18,B20,B24,B25,C17,HVY,H15,H16,H21,H28,NNN	
17	PAOZZ	3040014229390	34623	6006645	BALL JOINT.....	2
					UOC:BVY,B15,B20,B24,B25,C17,NNN	
17	PAOZZ	3040013582102	19207	12342645	BALL JOINT LOWER.....	2
					UOC:AVY,A11,A13,A14,A15,A20,A24,A25,A26,A27,B16,B17,B18,HVY,H15,H16,H21,H28	
17	PAOZZ	3040011883684	34623	12338328	PARTS KIT,BALL JOIN.....	2
					UOC:H11,H13,H14,H17,H18,H20,H24,H25,H26,H27,MMM	
18	PAOZZ	5310008507004	96906	MS35692-54	.NUT,PLAIN,SLOTTED,H 5/8-18.....	1
19	PAOZZ	4730000504203	96906	MS15001-1	.FITTING,LUBRICATION.....	1
20	PAOZZ	2530011757212	34623	5579475	ARM,CONTROL,VEHICUL LOWER,L.H.....	1
					UOC:H11,H13,H14,H17,H18,H20,H24,H25,H26,H27,MMM	
20	PAOZZ	2530011757213	34623	5579474	ARM,CONTROL,VEHICUL LOWER,R.H.....	1
					UOC:H11,H13,H14,H17,H18,H20,H24,H25,H26,H27,MMM	
20	PAOFF	2530012564914	19207	12340860-1	ARM,CONTROL,VEHICUL LOWER,L.H.....	1
					UOC:AVY,A11,A13,A14,A15,A20,A24,A25,A26,A27,B16,B17,B18,HVY,H15,H16,H21,H28	
20	PAOFF	2530012573905	19207	12340860-2	ARM,CONTROL,VEHICUL LOWER,R.H.....	1
					UOC:AVY,A11,A13,A14,A15,A20,A24,A25,A26,A27,B16,B17,B18,HVY,H15,H16,H21,H28	



SECTION II			TM9-2320-280-24P			
(1)	(2)	(3)	(4)	(5)	(6)	(7)
ITEM	SMR			PART		
NO	CODE	NSN	CAGEC	NUMBER	DESCRIPTION AND USABLE ON CODES(UC)	QTY
20	PAOFF	2530014208634	34623	RCSK17249	ARM,CONTROL,VEHICUL LOWER,L.H.....	1
					UOC:BVY,B15,B20,B24,B25,C17,NNN	
20	PAOFF	2530014207895	34623	RCSK17250	ARM,CONTROL,VEHICUL LOWER,R.H.....	1
					UOC:BVY,B15,B20,B24,B25,C17,NNN	
21	PAFZZ	3120011865527	19207	12338270	.BUSHING,SLEEVE LOWER.....	2

END OF FIGURE

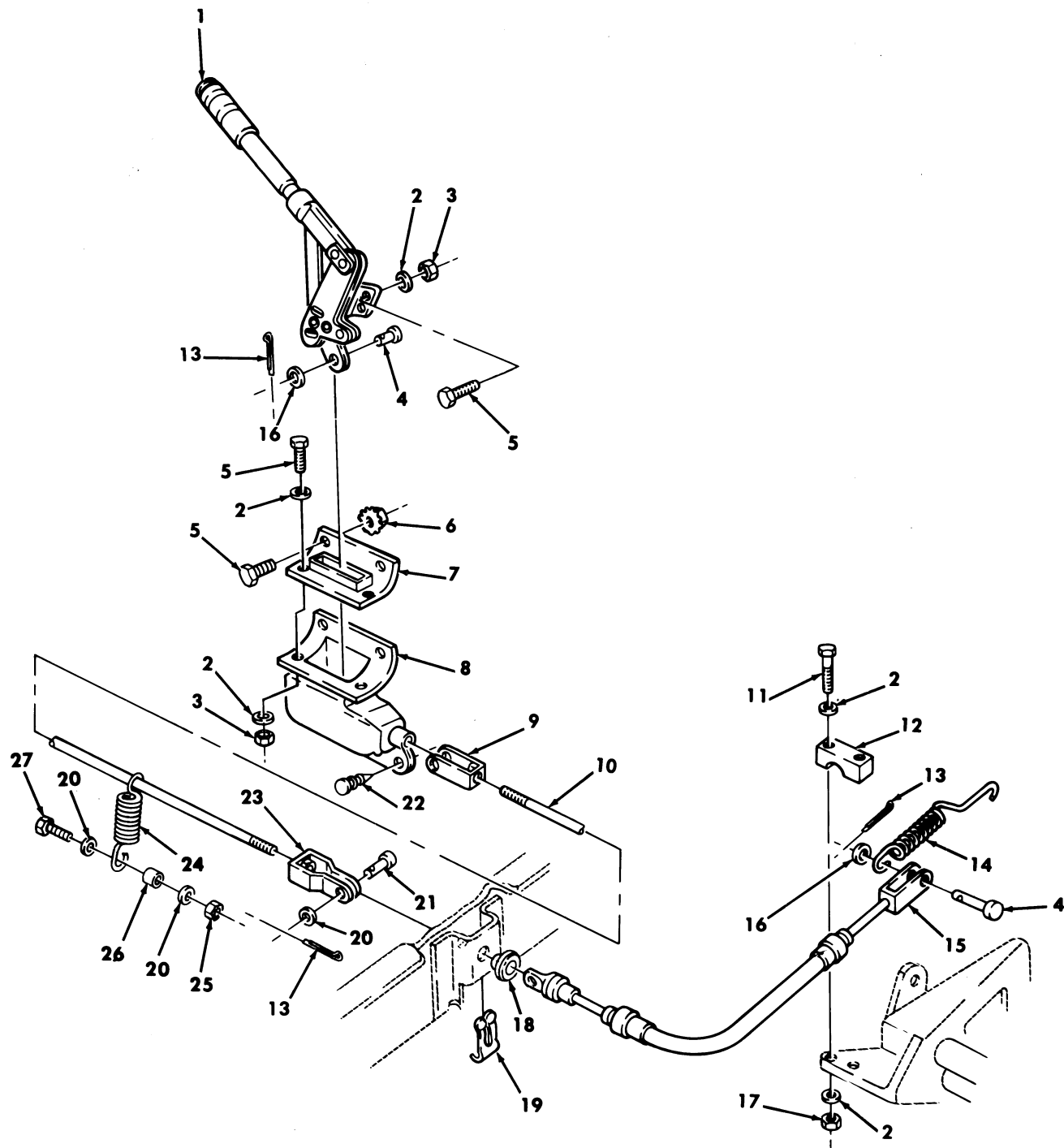

Figure 153. Parking Brake Hand Lever and Cable.

SECTION II			TM9-2320-280-24P			
(1)	(2)	(3)	(4)	(5)	(6)	(7)
ITEM	SMR			PART		
NO	CODE	NSN	CAGEC	NUMBER	DESCRIPTION AND USABLE ON CODES(UC)	QTY
GROUP 12 BRAKES						
1201 HAND BRAKES						
FIG. 153 PARKING BRAKE HAND LEVER AND CABLE						
1	PAOZZ	5340013804561	19207	12342679	LEVER, LOCK-RELEASE.....	1
2	PAOZZ	5310011023270	24617	2436161	WASHER, FLAT 1/4.....	11
3	PAOZZ	5310014326727	24617	9419471	NUT, SELF-LOCKING, HE 1/4-20.....	4
4	PAOZZ	5315008158840	96906	MS35810-4	PIN, STRAIGHT, HEADED 3/8 X 1-1/16...	2
5	PAOZZ	5305002253843	80204	B1821BH025C100N	SCREW, CAP, HEXAGON H 1/4-20 X 1.00..	6
6	PAOZZ	5310012522999	34623	5593033	NUT, SELF-LOCKING, AS 1/4-20.....	2
UC: H11, H13, H14, H17, H18, H24, H25, H26, H27, MMM						
7	PAOZZ	2530011883520	19207	12338295	BOOT, VEHICULAR COMP UPPER.....	1
8	PAOZZ	2530011888446	19207	12338291	BOOT, VEHICULAR COMP LOWER.....	1
9	PAOZZ	5340012135600	92867	95001418	CLEVIS, ROD END.....	1
10	PAOZZ	5306011973277	19207	12338294	ROD, THREADED END USBL EFF 1 THRU 44824.....	1
UC: H11, H13, H14, H17, H18, H24, H25, H26, H27, MMM						
11	PAOZZ	5305000712510	80204	B1821BH025C175N	SCREW, CAP, HEXAGON H 1/4-20 X 1.75, USBL EFF 1 THRU 44824.....	2
UC: H11, H13, H14, H17, H18, H24, H25, H26, H27, MMM						
12	PAOZZ	5340013589301	19207	12338867	CLAMP, BLOCK, SECTION USBL EFF 1 THRU 44824.....	1
UC: H11, H13, H14, H17, H18, H24, H25, H26, H27, MMM						
13	PAOZZ	5315008423044	14351	X601	PIN, COTTER 3/32 X 3/4, USBL EFF 1 THRU 44824.....	3
UC: H11, H13, H14, H17, H18, H24, H25, H26, H27, MMM						
14	PAOZZ	5360012143695	34623	5590602	SPRING, HELICAL, EXTE USBL EFF 1 THRU 44824.....	1
UC: H11, H13, H14, H17, H18, H24, H25, H26, H27, MMM						
15	PAOZZ	2590012124955	92867	15480200	CONTROL ASSEMBLY, PU USBL EFF 1 THRU 44824.....	1
UC: H11, H13, H14, H17, H18, H24, H25, H26, H27, MMM						
16	PAOZZ	5310000877493	96906	MS27183-13	WASHER, FLAT 3/8, USBL EFF 1 THRU 44824.....	2
UC: H11, H13, H14, H17, H18, H24, H25, H26, H27, MMM						
17	PAOZZ	5310000614650	96906	MS51943-31	NUT, SELF-LOCKING, HE 1/4-20, USBL EFF 1 THRU 44824.....	2
UC: H11, H13, H14, H17, H18, H24, H25, H26, H27, MMM						
18	PAOZZ	5975012113142	28520	SB-750-625-2840	BUSHING, ELECTRICAL USBL EFF 1 THRU 44824.....	1
UC: H11, H13, H14, H17, H18, H24, H25, H26, H27, MMM						

SECTION II			TM9-2320-280-24P			
(1)	(2)	(3)	(4)	(5)	(6)	(7)
ITEM NO	SMR CODE	NSN	CAGEC	PART NUMBER	DESCRIPTION AND USABLE ON CODES(UC)	QTY
19	PAOZZ	5340012097807	34623	5588032	CLIP,SPRING TENSION USBL EFF 1 THRU 44824..... UOC:H11,H13,H14,H17,H18,H24,H25,H26,H27,MMM	1
20	PAOZZ	5310012520512	34623	5592832	WASHER,FLAT 5/16-18,USBL EFF 1 THRU 44824..... UOC:H11,H13,H14,H17,H18,H24,H25,H26,H27,MMM	3
21	PAOZZ	5315007540848	96906	MS35810-3	PIN,STRAIGHT,HEADED 5/16 X 5/16, USBL EFF 1 THRU 44824..... UOC:H11,H13,H14,H17,H18,H24,H25,H26,H27,MMM	1
22	PAOZZ	5325011973460	02768	354-280308-00-00 78	FASTENER,SPRING TEN USBL EFF 1 THRU 44824..... UOC:H11,H13,H14,H17,H18,H24,H25,H26,H27,MMM	1
23	PAOZZ	5340012117562	92867	95001419	CLEVIS,ROD END USBL EFF 1 THRU 44824..... UOC:H11,H13,H14,H17,H18,H24,H25,H26,H27,MMM	1
24	PAOZZ	5360012600700	34623	5593978	SPRING,HELICAL,EXTE USBL EFF 1 THRU 44824..... UOC:H11,H13,H14,H17,H18,H24,H25,H26,H27,MMM	1
25	PAOZZ	5310008140673	96906	MS51943-33	NUT,SELF-LOCKING,HE 5/16-18,USBL EFF 1 THRU 44824..... UOC:H11,H13,H14,H17,H18,H24,H25,H26,H27,MMM	1
26	PAOZZ	5365012550965	34623	5596306	SPACER,SLEEVE USBL EFF 1 THRU 44824..... UOC:H11,H13,H14,H17,H18,H24,H25,H26,H27,MMM	1
27	PAOZZ	5306002258499	96906	MS90725-34	BOLT,MACHINE 5/16-18 X 1.00,USBL EFF 1 THRU 44824..... UOC:H11,H13,H14,H17,H18,H24,H25,H26,H27,MMM	1

END OF FIGURE

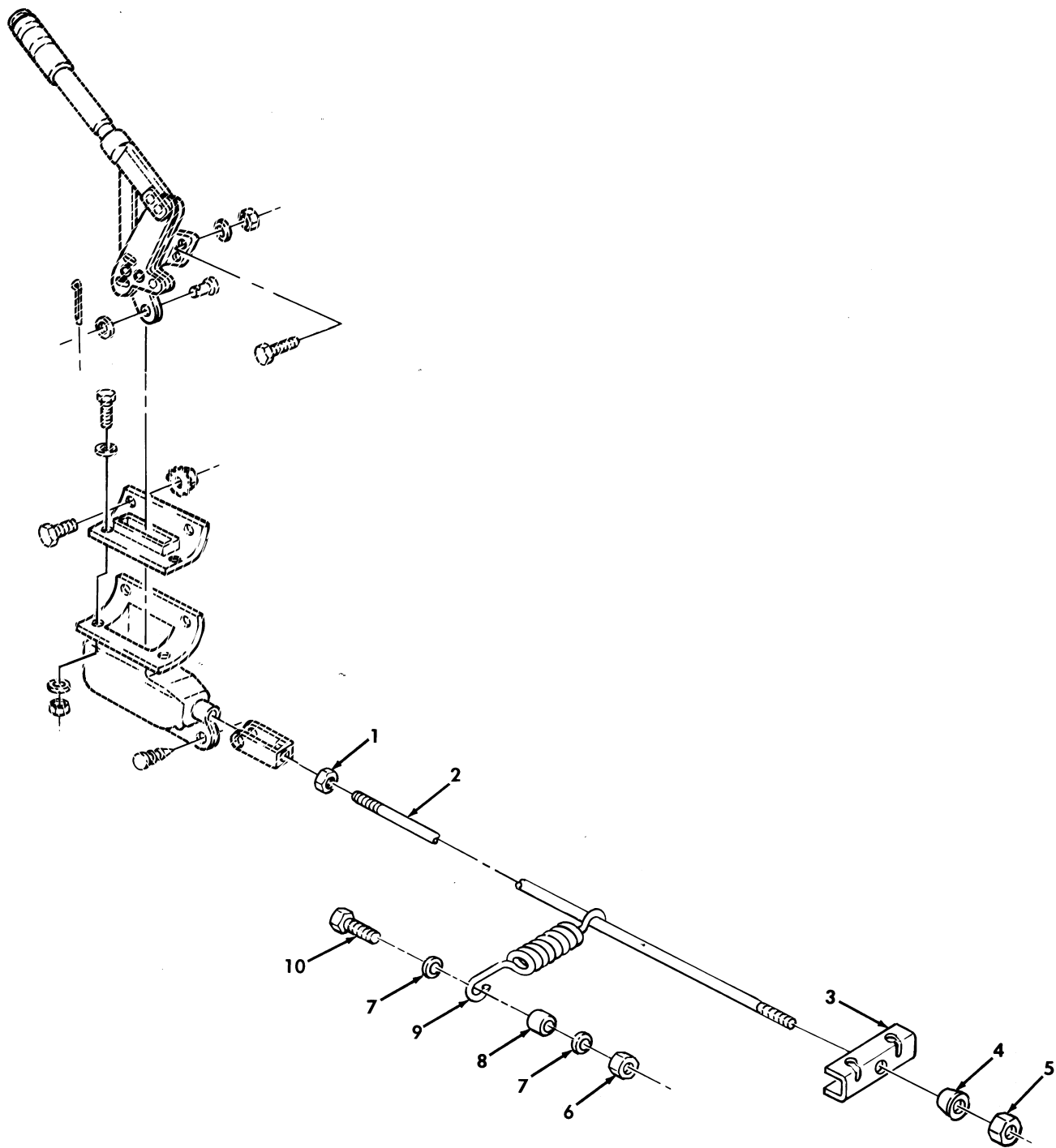

Figure 154. Parking Brake Rod and Related Parts.

SECTION II			TM9-2320-280-24P			
(1)	(2)	(3)	(4)	(5)	(6)	(7)
ITEM	SMR			PART		
NO	CODE	NSN	CAGEC	NUMBER	DESCRIPTION AND USABLE ON CODES(UOC)	QTY
GROUP 1201 HAND BRAKES						
FIG. 154 PARKING BRAKE ROD AND RELATED PARTS						
1	PAOZZ	5310011027356	24617	9421077	NUT,PLAIN,HEXAGON 5/16-24,USBL EFF 44825 AND ABOVE.....	1
2	PFOZZ	5306012736333	19207	12341895	ROD,THREADED END USBL EFF 44825 AND ABOVE.....	1
3	PFOZZ	2530012914597	34623	5597334	BAR,BRAKE CABLE USBL EFF 44825 AND ABOVE.....	1
4	PAOZZ	5310012895455	19207	12341897	WASHER,CONVEX 5/16,USBL EFF 44825 AND ABOVE.....	1
5	PAOZZ	5310002416658	96906	MS51943-34	NUT,SELF-LOCKING,HE 5/16-24,USBL EFF 44825 AND ABOVE.....	1
6	PAOZZ	5310008140673	96906	MS51943-33	NUT,SELF-LOCKING,HE 5/16-18,USBL EFF 44825 AND ABOVE.....	1
7	PAOZZ	5310000814219	96906	MS27183-12	WASHER,FLAT 5/16,USBL EFF 44825 AND ABOVE.....	2
8	PAOZZ	5365012550965	34623	5596306	SPACER,SLEEVE USBL EFF 44825 AND ABOVE.....	1
9	PAOZZ	5360012600700	4V120	SP-067-500-24540 SS-E	SPRING,HELICAL,EXTE USBL EFF 44825 AND ABOVE.....	1
10	PAOZZ	5306002258499	96906	MS90725-34	BOLT,MACHINE 5/16-18 X 1.00,USBL EFF 44825 AND ABOVE.....	1

END OF FIGURE

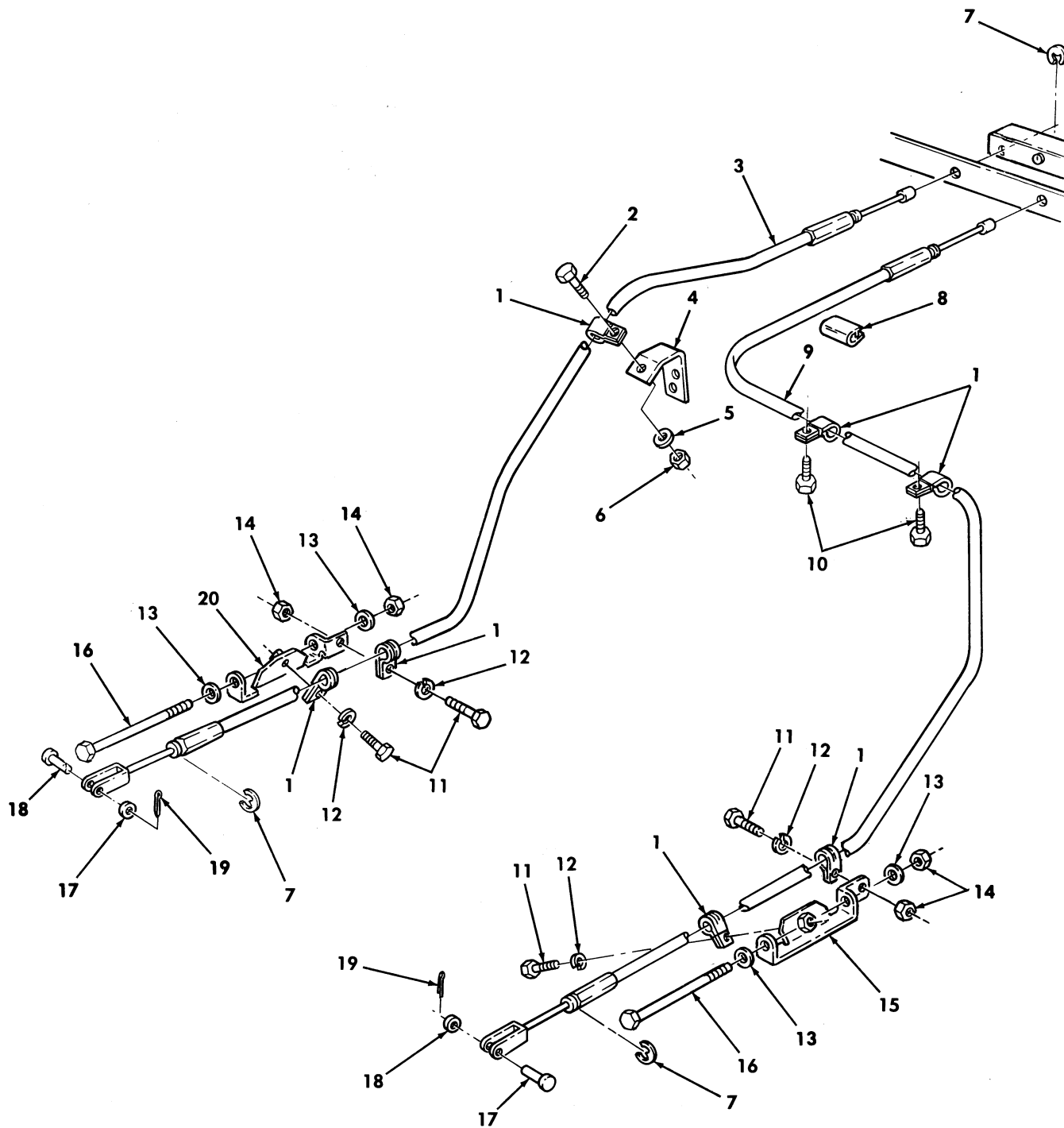

Figure 155. Parking Brake Cables and Mounting Hardware.

SECTION II			TM9-2320-280-24P			
(1)	(2)	(3)	(4)	(5)	(6)	(7)
ITEM NO	SMR CODE	NSN	CAGEC	PART NUMBER	DESCRIPTION AND USABLE ON CODES(UOC)	QTY
GROUP 1201 HAND BRAKES						
FIG. 155 PARKING BRAKE CABLES AND MOUNTING HARDWARE						
1	PAOZZ	5340000881254	96906	MS21333-104	CLAMP,LOOP USBL EFF 44825 AND ABOVE	7
2	PAOZZ	5305000680502	96906	MS90725-6	SCREW,CAP,HEXAGON H 1/4-20 X 3/4, USBL EFF 44825 AND ABOVE.....	1
3	PAOZZ	2590012653185	92867	15541800	CONTROL ASSEMBLY,PU L.H.,USBL EFF 44825 AND ABOVE.....	1
4	PFOZZ	5340012774427	34623	5597360	BRACKET,DOUBLE ANGL USBL EFF 44825 AND ABOVE.....	1
5	PAOZZ	5310008094058	96906	MS27183-10	WASHER,FLAT 1/4,USBL EFF 44825 AND ABOVE.....	1
6	PAOZZ	5310011520598	24617	2711172	NUT,SELF-LOCKING,AS 1/4-20,USBL EFF 44825 AND ABOVE.....	1
7	PAOZZ	5325004425845	96906	MS16633-1050	RING,RETAINING USBL EFF 44825 AND ABOVE.....	4
8	PAOZZ	5342012749884	34623	5597890	BUMPER,SPECIAL USBL EFF 44825 AMD ABOVE.....	1
9	PAOZZ	2590013235153	92867	15541802	CONTROL ASSEMBLY,PU R.H.,USBL EFF 44825 AND ABOVE.....	1
10	PAOZZ	5305012645809	19207	12342499-2	SCREW,TAPPING THREA #10-32 X .62, USBL EFF 44825 AND ABOVE.....	2
11	PAOZZ	5305000687837	80204	B1821BH025C063N	SCREW,CAP,HEXAGON H 1/4-20 X 5/8, USBL EFF 44825 AND ABOVE.....	4
12	PAOZZ	5310005825965	96906	MS35338-44	WASHER,LOCK 1/4,USBL EFF 44825 AND ABOVE.....	4
13	PAOZZ	5310011023270	24617	2436161	WASHER,FLAT 1/4,USBL EFF 44825 AND ABOVE.....	4
14	PAOZZ	5310014326727	24617	9419471	NUT,SELF-LOCKING,HE 1/4-20 USBL EFF 44825 AND ABOVE.....	4
15	PAOZZ	5340013942408	19207	12342965	BRACKET,MOUNTING R.H. USBL EFF 44825 AND ABOVE.....	1
16	PAOZZ	5305012022676	80204	B1821BH025C450N	SCREW,CAP,HEXAGON H 1/4-20 X 4.50, USBL EFF 44825 AND ABOVE.....	2
17	PAOZZ	5315008158840	96906	MS35810-4	PIN,STRAIGHT,HEADED USBL EFF 44825 AND ABOVE.....	2
18	PAOZZ	5310012057923	34623	5593213	WASHER,FLAT 3/8,USBL EFF 44825 AND ABOVE.....	2
19	PAOZZ	5315008423044	96906	MS24665-283	PIN,COTTER USBL EFF 44825 AND ABOVE	2
20	PAOZZ	5340013948496	19207	12342966	BRACKET,MOUNTING L.H. USBL EFF 44825 AND ABOVE.....	1

END OF FIGURE



1 — 2  
thru  
15

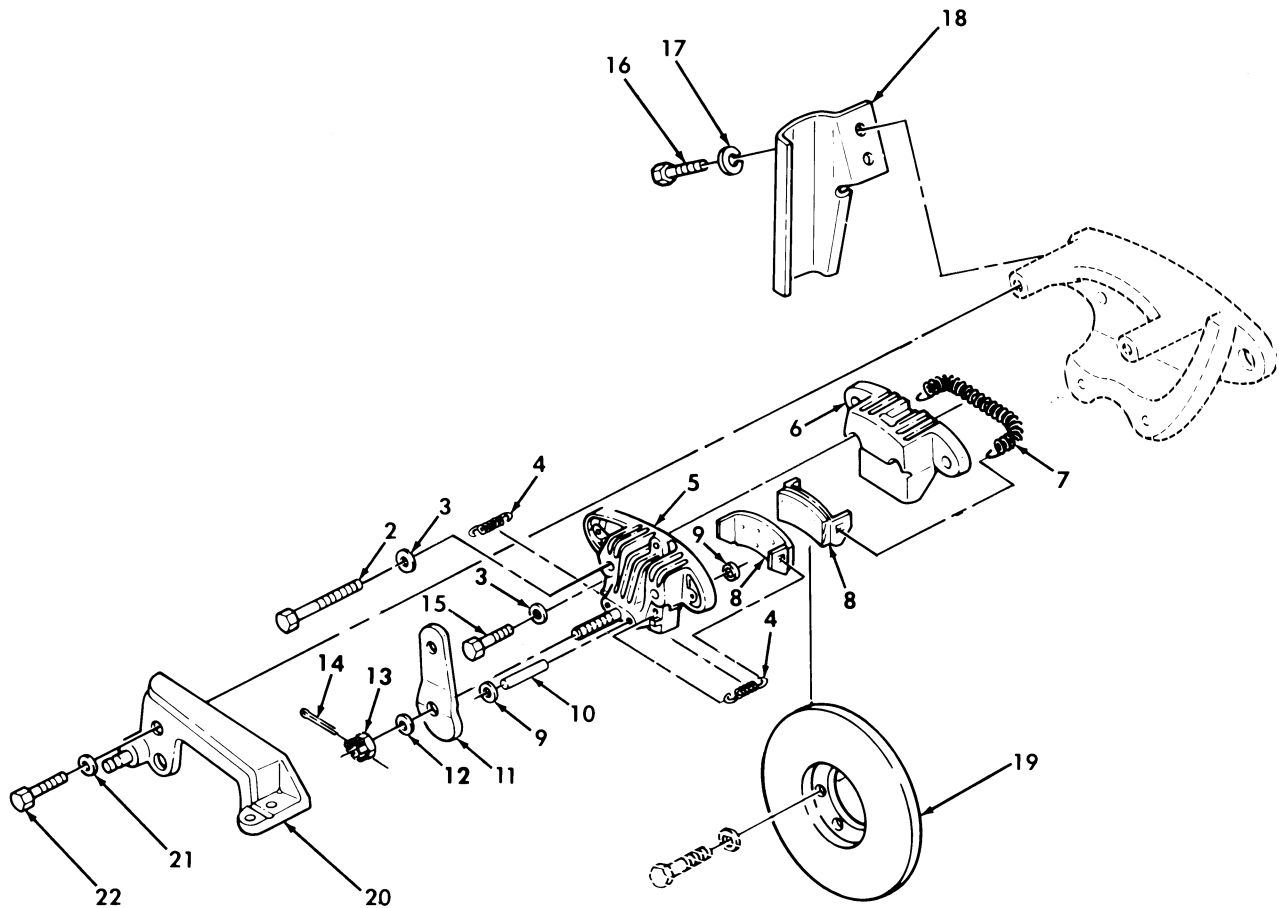

Figure 156. Parking Brake Caliper, Rotor, and Mounting Hardware.

SECTION II			TM9-2320-280-24P			
(1)	(2)	(3)	(4)	(5)	(6)	(7)
ITEM	SMR			PART		
NO	CODE	NSN	CAGEC	NUMBER	DESCRIPTION AND USABLE ON CODES(UOC)	QTY
GROUP 1201 HAND BRAKES						
FIG. 156 PARKING BRAKE CALIPER, ROTOR,AND MOUNTING HARDWARE						
1	PAOOO	2530011747441	33116	D00-09102	CALIPER,DISC BRAKE USBL EFF 1 THRU 44824.....	1
					UOC:H11,H13,H14,H17,H18,H24,H25,H26, H27,MMM	
2	PAOZZ	5305011854628	34623	5740912	.SCREW,CAP,HEXAGON H 3/8-16 X 3.50, USBL EFF 1 THRU 44824.....	2
					UOC:H11,H13,H14,H17,H18,H24,H25,H26, H27,MMM	
3	PAOZZ	5310014770828	22075	A03-002204	.WASHER,FLAT 3/8,USBL EFF 1 THRU 44824.....	3
					UOC:H11,H13,H14,H17,H18,H24,H25,H26, H27,MMM	
4	PFOZZ	5360012659116	34623	5593847	.SPRING,HELICAL,EXTE USBL EFF 1 THRU 44824 PART OF KIT P/N A98-09439	2
					UOC:H11,H13,H14,H17,H18,H24,H25,H26, H27,MMM	
5	XAOZZ		34623	5740910	.CAM,SIDE INNER,USBL EFF 1 THRU 44824.....	1
					UOC:H11,H13,H14,H17,H18,H24,H25,H26, H27,MMM	
6	XAOZZ		34623	5740911	.CAM,SIDE OUTER,USBL EFF 1 THRU 44824.....	1
					UOC:H11,H13,H14,H17,H18,H24,H25,H26, H27,MMM	
7	PFOZZ	5360011858809	34623	5740909	.SPRING,HELICAL,EXTE USBL EFF 1 THRU 44824.....	1
					UOC:H11,H13,H14,H17,H18,H24,H25,H26, H27,MMM	
8	KFOZZ		34623	5740908	.DISC,BRAKE USBL EFF 1 THRU 44824 PART OF KIT P/N A98-09439.....	2
					UOC:H11,H13,H14,H17,H18,H24,H25,H26, H27,MMM	
9	PAOZZ	5330012111343	34623	5741141	.GASKET USBL EFF 1 THRU 44824.....	4
					UOC:H11,H13,H14,H17,H18,H24,H25,H26, H27,MMM	
10	PAOZZ	5315012903327	34623	5740913	.PIN,STRAIGHT,HEADLE USBL EFF 1 THRU 44824.....	2
					UOC:H11,H13,H14,H17,H18,H24,H25,H26, H27,MMM	
11	PAOZZ	3040014653178	34623	5590540	.BELL CRANK USBL EFF 1 THRU 44824..	1
					UOC:H11,H13,H14,H17,H18,H24,H25,H26, H27,MMM	
12	PAOZZ	5310011858691	34623	5740916	.WASHER,FLAT 1/2,USBL EFF 1 THRU 44824.....	1
					UOC:H11,H13,H14,H17,H18,H24,H25,H26, H27,MMM	
13	PAOZZ	5310011865420	22075	A02-08052	.NUT,SLEEVE USBL EFF 1 THRU 44824..	1
					UOC:H11,H13,H14,H17,H18,H24,H25,H26,	

SECTION II			TM9-2320-280-24P			
(1)	(2)	(3)	(4)	(5)	(6)	(7)
ITEM	SMR			PART		
NO	CODE	NSN	CAGEC	NUMBER	DESCRIPTION AND USABLE ON CODES(UOC)	QTY
14	PAOZZ	5315000137228	96906	MS24665-423	H27,MMM .PIN,COTTER USBL EFF 1 THRU 44824.. UOC:H11,H13,H14,H17,H18,H24,H25,H26, H27,MMM	1
15	PAOZZ	5305011858673	34623	5740919	.SCREW,CAP,HEXAGON H 3/8-16 X 1.75, USBL EFF 1 THRU 44824..... UOC:H11,H13,H14,H17,H18,H24,H25,H26, H27,MMM	1
16	PAOZZ	5305000712506	80204	B1821BH025C050N	SCREW,CAP,HEXAGON H 1/4-20 X 1/2, USBL EFF 1 THRU 44824..... UOC:H11,H13,H14,H17,H18,H24,H25,H26, H27,MMM	2
17	PAOZZ	5310005825965	96906	MS35338-44	WASHER,LOCK 1/4, USBL EFF 1 THRU 44824..... UOC:H11,H13,H14,H17,H18,H24,H25,H26, H27,MMM	2
18	PFOZZ	2530011877161	19207	12338290	SHIELD,BRAKE DISK USBL EFF 1 THRU 44824..... UOC:H11,H13,H14,H17,H18,H24,H25,H26, H27,MMM	1
19	PAOFF	2530011849821	34623	5577659	ROTOR,DISC BRAKE USBL EFF 1 THRU 44824..... UOC:H11,H13,H14,H17,H18,H24,H25,H26, H27,MMM	1
20	PAOZZ	2590011877039	34623	5590530	BRACKET,VEHICULAR C USBL EFF 1 THRU 44824..... UOC:H11,H13,H14,H17,H18,H24,H25,H26, H27,MMM	1
21	PAOZZ	5310005845272	96906	MS35338-48	WASHER,LOCK 1/2,USBL EFF 1 THRU 44824..... UOC:H11,H13,H14,H17,H18,H24,H25,H26, H27,MMM	2
22	PAOZZ	5305009158087	80204	B1821BH050C125D	SCREW,CAP,HEXAGON H 1/2-13 X 1.25, USBL EFF 1 THRU 44824..... UOC:H11,H13,H14,H17,H18,H24,H25,H26, H27,MMM	2

END OF FIGURE

5 — 6  
thru  
15

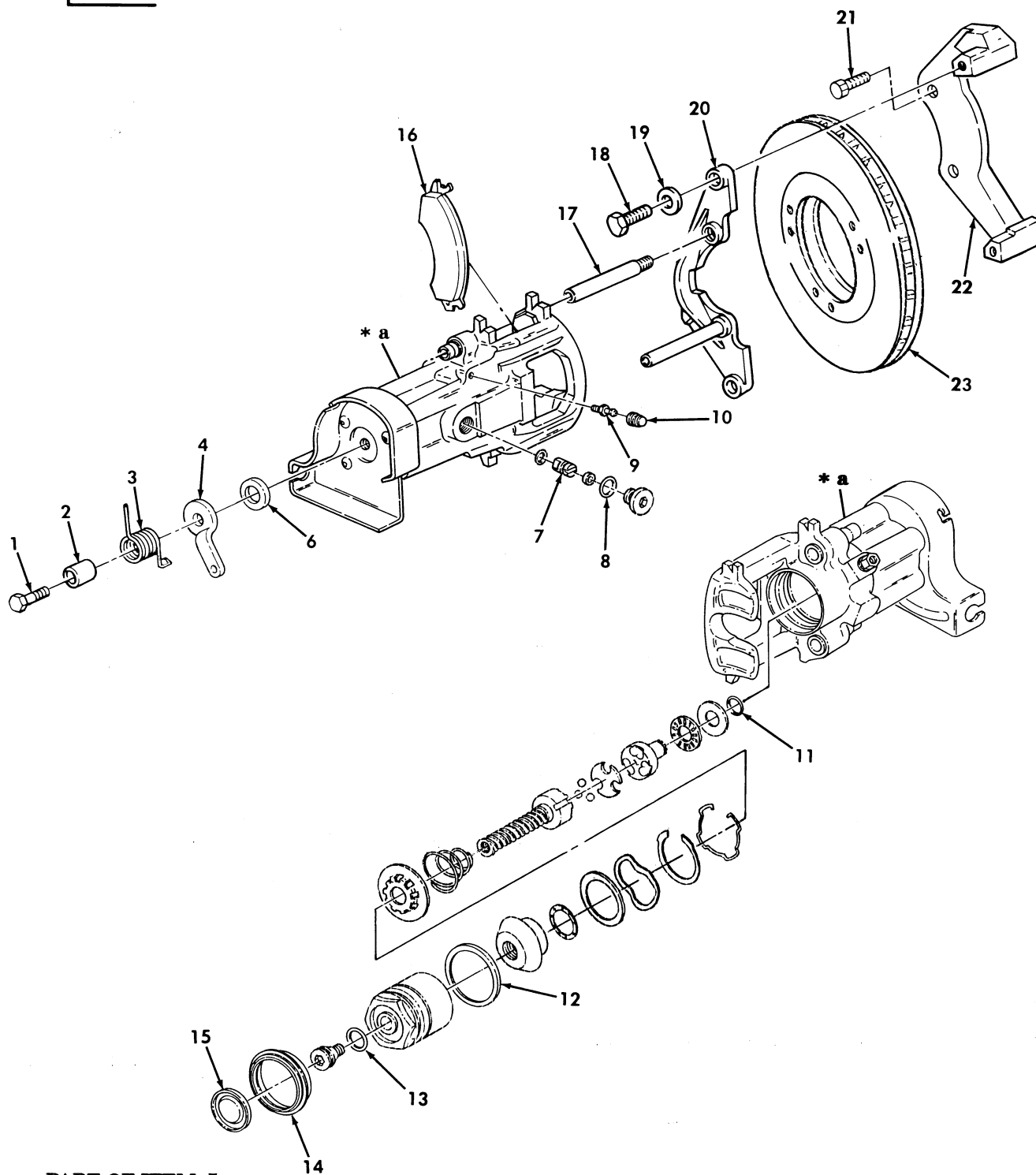

\* a PART OF ITEM 5

Figure 157. Rear Parking Brake and Caliper Assembly.

SECTION II		TM9-2320-280-24P				
(1)	(2)	(3)	(4)	(5)	(6)	(7)
ITEM NO	SMR CODE	NSN	CAGEC	PART NUMBER	DESCRIPTION AND USABLE ON CODES(UC)	QTY
GROUP 1201 HAND BRAKES						
FIG. 157 REAR PARKING BRAKE AND CALIPER ASSEMBLY						
1	PAOZZ	5305012764855	34281	109457-01	SCREW,CAP,HEXAGON H.....	1
2	PAOZZ	5340012658883	34281	1215567-01	CAP,PROTECTIVE,DUST.....	1
3	PAOZZ	5360012658798	34623	5741995	SPRING,HELICAL,EXTE REAR,L.H.....	1
3	PAOZZ	5360012658799	34623	5741994	SPRING,HELICAL,EXTE REAR R.H.....	1
4	PAOZZ	2530012653148	34623	5741750	ARM,LEVER,BRAKE REAR, L.H.....	1
4	PAOZZ	2530012653153	34623	5741748	ARM,LEVER,BRAKE REAR,R.H.....	1
5	PAOFF	2530013336068	27767	12173602	CALIPER ASSEMBLY,DI REAR, L.H.....	1
5	PAOFF	2530013338263	27767	12173601-01	CALIPER ASSEMBLY,DI REAR, R.H.....	1
6	KFFZZ		34821	109433-01	.SEAL,ACTUATOR SHAFT PART OF KIT P/N 57K3512.....	1
7	KFFZZ		34281	120100-07	.O-RING,ANTI-ROTATIO PART OF KIT P/N 57K3512.....	1
8	KFFZZ		34281	120100-08	.O-RING,PIN RETAININ PART OF KIT P/N 57K3512.....	1
9	PAOZZ	2530003401405	34623	5578802	.BLEEDER VALVE,HYDRA REAR,USBL EFF 44825 AND ABOVE.....	1
10	PAOZZ	5340011861817	34723	05597172	.CAP-PLUG,PROTECTIVE REAR.....	1
11	KFFZZ		34281	120100-10	.O-RING,ACTUATOR SHA PART OF KIT P/N 57K3512.....	1
12	KFFZZ		34281	092554-01	.GASKET PART OF KIT P/N 57K3512.....	1
13	KFFZZ		34281	120100-09	.O-RING,THRUST SCREW PART OF KIT P/N 57K3512.....	1
14	KFFZZ		34281	103712-01	.BOOT, VEHICULAR COM PART OF KIT P/N 57K3512.....	1
15	KFFZZ		34271	121743-01	.CAP,PISTON PART OF KIT P/N 57K3512.	1
16	PAOZZ	2530012532825	27767	106397-03	DISK BRAKE SHOE USBL EFF 44825 AND ABOVE PART OF KIT P/N 57K0262.....	4
16	KFOZZ		33116	106397-04	UOC:H11,H13,H14,H15,H16,H17,H18,H20,H21,H24,H25,H26,H27,H28,MMM DISK BRAKE SHOE PART OF KIT P/N 57K0264.....	4
16	KFOZZ		35281	12835400	UOC:AVY,A11,A13,A14,A15,A20,A24,A25,A26,A27,B16,B17,B18,HVY DISK BRAKE SHOE PART OF KIT P/N RCSK17215.....	4
17	PAOZZ	5305011858657	34281	099912-01	UOC:BVY,B15,B20,B24,B25,C17,NNN SETSCREW.....	2
18	PAOZZ	5305011858672	34281	096496-01	SCREW,CAP,HEXAGON H.....	2
19	PAOZZ	5310011858690	34281	091247-01	WASHER,FLAT 3/8.....	2
20	PAOZZ	2530011856713	34281	104534-01	YOKE,DISC BRAKE REAR.....	1
21	PAOZZ	5305007247220	80204	B1821BH063C150N	SCREW,CAP,HEXAGON H 5/8-11 X 1.50..	4
22	PAFZZ	2530013141129	22075	10453002	ADAPTER,BRAKE VALVE REAR L.H. AND R.H.....	2
22	PAFZZ	2530014628079	34281	12821501	UOC:AVY,A11,A13,A14,A15,A20,A24,A25,A26,A27,B16,B17,B18,HVY,H11,H13,H14,H15,H16,H17,H18,H20,H21,H24,H25,H26,H27,H28,MMM YOKE,BRAKE,VEHICULA REAR L.H. AND	2

SECTION II			TM9-2320-280-24P			
(1)	(2)	(3)	(4)	(5)	(6)	(7)
ITEM	SMR			PART		
NO	CODE	NSN	CAGEC	NUMBER	DESCRIPTION AND USABLE ON CODES(UC)	QTY
23	PAOFF	2530011856712	34281	106980-02	R.H..... UOC:BVY,B15,B20,B24,B25,C17,NNN	
					ROTOR,DISC BRAKE.....	2
					UOC:AVY,A11,A13,A14,A15,A20,A24,A25, A26,A27,B16,B17,B18,HVY,H11,H13,H14, H15,H16,H17,H18,H20,H21,H24,H25,H26, H27,H28,MMM	
23	PAOFF	2530014207904	34623	6002218	ROTOR,DISC BRAKE.....	2
					UOC:BVY,B15,B20,B24,B25,C17,NNN	

END OF FIGURE

2—  
3  
thru  
10

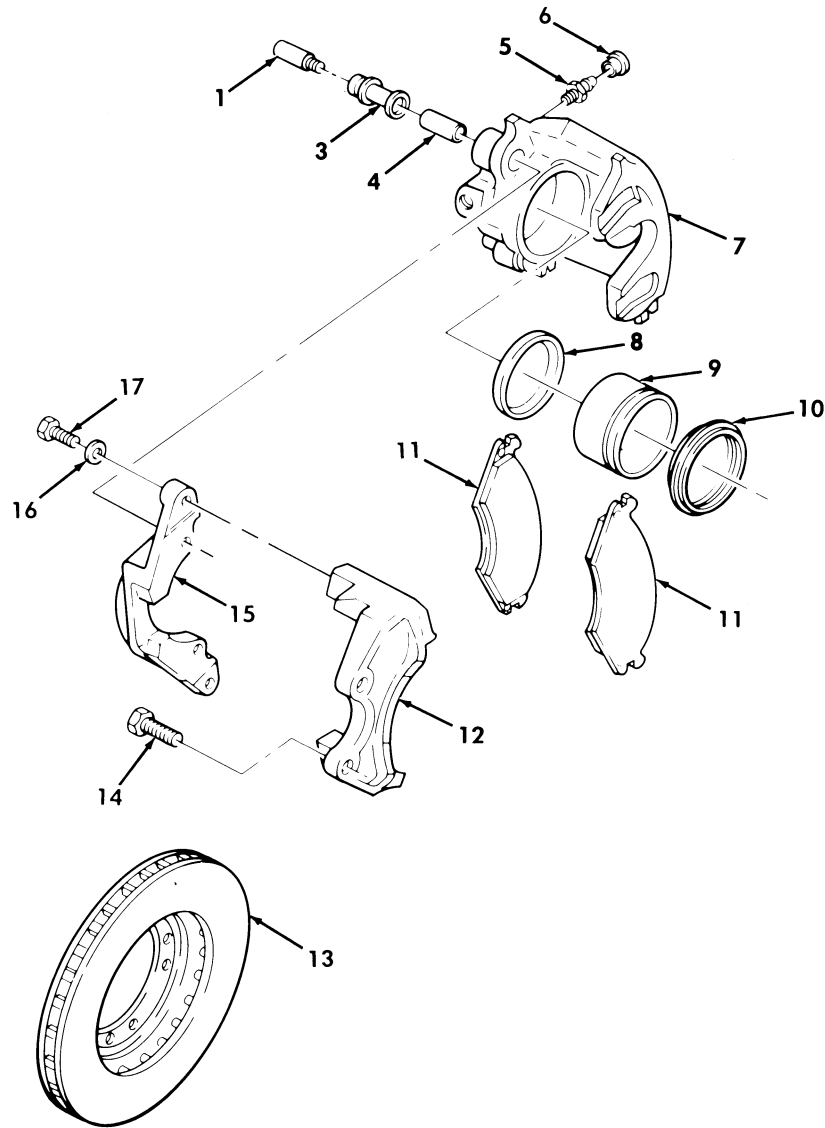

Figure 158. Service Brake Caliper Assembly and Rotor.

SECTION II			TM9-2320-280-24P			
(1)	(2)	(3)	(4)	(5)	(6)	(7)
ITEM NO	SMR CODE	NSN	CAGEC	PART NUMBER	DESCRIPTION AND USABLE ON CODES(UOC)	QTY
GROUP 1202 SERVICE BRAKES						
FIG. 158 SERVICE BRAKE CALIPER ASSEMBLY AND ROTOR						
1	PAOZZ	5305011858657	34281	099912-01	SETSCREW.....	4
2	PAOFF	2530012076256	34281	103700-02	HOUSING ASSEMBLY,CA REAR,R.H.,USBL EFF 1 THRU 44824..... UOC:H11,H13,H14,H17,H18,H24,H25,H26, H27,MMM	1
2	PAOFF	2530012042583	34281	103700-01	BRAKE,SINGLE DISK REAR,L.H.,USBL EFF 1 THRU 44824..... UOC:H11,H13,H14,H17,H18,H24,H25,H26, H27,MMM	1
2	PAOFF	2530012076256	34281	103700-02	HOUSING ASSEMBLY,CA FRONT,L.H..... UOC:AVY,A11,A13,A14,A15,A20,A24,A25, A26,A27,B16,B17,B18,HVY,H11,H13,H14, H15,H16,H17,H18,H20,H21,H24,H25,H26, H27,H28,MMM	1
2	PAOFF	2530012042583	34281	103700-01	BRAKE,SINGLE DISK FRONT,R.H..... UOC:AVY,A11,A13,A14,A15,A20,A24,A25, A26,A27,B16,B17,B18,HVY,H11,H13,H14, H15,H16,H17,H18,H20,H21,H24,H25,H26, H27,H28,MMM	1
2	PAOFF		34281	103700-09	HOUSING ASSEMBLY,CA FRONT,R.H..... UOC:BVY,B15,B20,B24,B25,C17,NNN	1
2	PAOFF		34281	103700-10	HOUSING ASSEMBLY,CA FRONT,L.H..... UOC:BVY,B15,B20,B24,B25,C17,NNN	1
3	PAOZZ	5365011867233	34281	108037-01	.BUSHING,NONMETALLIC.....	2
4	PAOZZ	3120011867181	34281	108039-01	.BEARING,SLEEVE.....	2
5	PAOZZ	2530003401405	34623	5578802	.BLEEDER VALVE,HYDRA.....	1
6	PAOZZ	5340011861817	34623	5597172	.CAP-PLUG,PROTECTIVE.....	1
7	XAFZZ		34281	103706-05	.HOUSING,CALIPER REAR,L.H.,USBL EFF 1 THRU 44824..... UOC:H11,H13,H14,H17,H18,H24,H25,H26, H27,MMM	1
7	XAFZZ		34281	103706-06	.HOUSING,CALIPER REAR,R.H.,USBL EFF 1 THRU 44824..... UOC:H11,H13,H14,H17,H18,H24,H25,H26, H27,MMM	1
7	XAFZZ		34281	103706-06	.HOUSING,CALIPER FRONT,L.H..... UOC:AVY,A11,A13,A14,A15,A20,A24,A25, A26,A27,B16,B17,B18,HVY,H11,H13,H14, H15,H16,H17,H18,H20,H21,H24,H25,H26, H27,H28,MMM	1
7	XAFZZ		34281	103706-05	.HOUSING,CALIPER FRONT,R.H..... UOC:AVY,A11,A13,A14,A15,A20,A24,A25, A26,A27,B16,B17,B18,HVY,H11,H13,H14, H15,H16,H17,H18,H20,H21,H24,H25,H26, H27,H28,MMM	1
7	XAFZZ		34281	103706-07	.HOUSING,CALIPER FRONT,R.H..... UOC:BVY,B15,B20,B24,B25,C17,NNN	1
7	XAFZZ		34281	103706-08	.HOUSING,CALIPER FRONT,L.H.....	1



SECTION II			TM9-2320-280-24P			
(1)	(2)	(3)	(4)	(5)	(6)	(7)
ITEM NO	SMR CODE	NSN	CAGEC	PART NUMBER	DESCRIPTION AND USABLE ON CODES(UC)	QTY
8	PAFZZ	5330011845421	34281	092554-01	UOC:BVY,B15,B20,B24,B25,C17,NNN .GASKET PART OF KIT P/N 11021.....	1
9	PAFZZ	2530011856714	34281	10371009	.PISTON,DISC BRAKE.....	1
10	PAFZZ	2530011857998	34281	103712-01	.BOOT, VEHICULAR COM PART OF KIT P/N 11021.....	1
11	KFOZZ		33116	106397-04	DISK BRAKE SHOE PART OF KIT P/N 57K0264.....	4
11	KFOZZ		27767	106397-03	UOC:AVY,A11,A13,A14,A15,A20,A24,A25, A26,A27,B16,B17,B18,HVY DISK BRAKE SHOE FRONT AND REAR, USBL EFF 1 THRU 44824 PART OF KIT P/N 57K0262.....	4
11	KFOZZ		34281	12835400	UOC:H11,H13,H14,H15,H16,H17,H18,H20, H21,H24,H25,H26,H27,H28,MMM BRAKE SHOE SET PART OF KIT P/N RCSK17215.....	4
12	PFOZZ	2530011853879	34623	5578809	UOC:BVY,B15,B20,B24,B25,C17,NNN ADAPTER,DISC BRAKE FRONT,L.H.....	1
12	PFOZZ	2530013141129	22075	10453002	UOC:AVY,A11,A13,A14,A15,A20,A24,A25, A26,A27,B16,B17,B18,HVY,H11,H13,H14, H15,H16,H17,H18,H20,H21,H24,H25,H26, H27,H28,MMM ADAPTER,BRAKE VALVE LEFT AND RIGHT REAR,USBL EFF 1 THRU 44824.....	1
12	PFOZZ	2530013141129	22075	10453002	UOC:H11,H13,H14,H17,H18,H24,H25,H26, H27,MMM ADAPTER,BRAKE VALVE FRONT,R.H.....	1
12	PFOZZ	2530014628079	34281	12821501	UOC:AVY,A11,A13,A14,A15,A20,A24,A25, A26,A27,B16,B17,B18,HVY,H11,H13,H14, H15,H16,H17,H18,H20,H21,H24,H25,H26, H27,H28,MMM YOKE,BRAKE,VEHICULA FRONT,R.H.....	1
12	PFOZZ	2530014628068	34281	12821801	UOC:BVY,B15,B20,B24,B25,C17,NNN YOKE,BRAKE,VEHICULA FRONT,L.H.....	1
13	PAOFF	2530011856712	34281	106980-02	UOC:BVY,B15,B20,B24,B25,C17,NNN ROTOR,DISC BRAKE.....	2
13	PAOFF	2530014207904	34623	6002218	UOC:AVY,A11,A13,A14,A15,A20,A24,A25, A26,A27,B16,B17,B18,HVY,H11,H13,H14, H15,H16,H17,H18,H20,H21,H24,H25,H26, H27,H28,MMM ROTOR,DISC BRAKE.....	2
14	PAOZZ	5305007247220	80204	B1821BH063C150N	UOC:BVY,B15,B20,B24,B25,C17,NNN SCREW,CAP,HEXAGON H 5/8-11 X 1.50..	8
15	PFOZZ	2530011856713	34281	104534-01	YOKE,DISC BRAKE.....	2
16	PAOZZ	5310011858690	34281	091247-01	WASHER,FLAT 3/8.....	4
17	PAOZZ	5305011858672	34281	096496-01	SCREW,CAP,HEXAGON H 3/8-16 X 1.00..	4

END OF FIGURE

**USE WITH BASIC AND A1 VEHICLES**

**HEAVY AND A1 VEHICLES**

**BASIC VEHICLES ONLY**

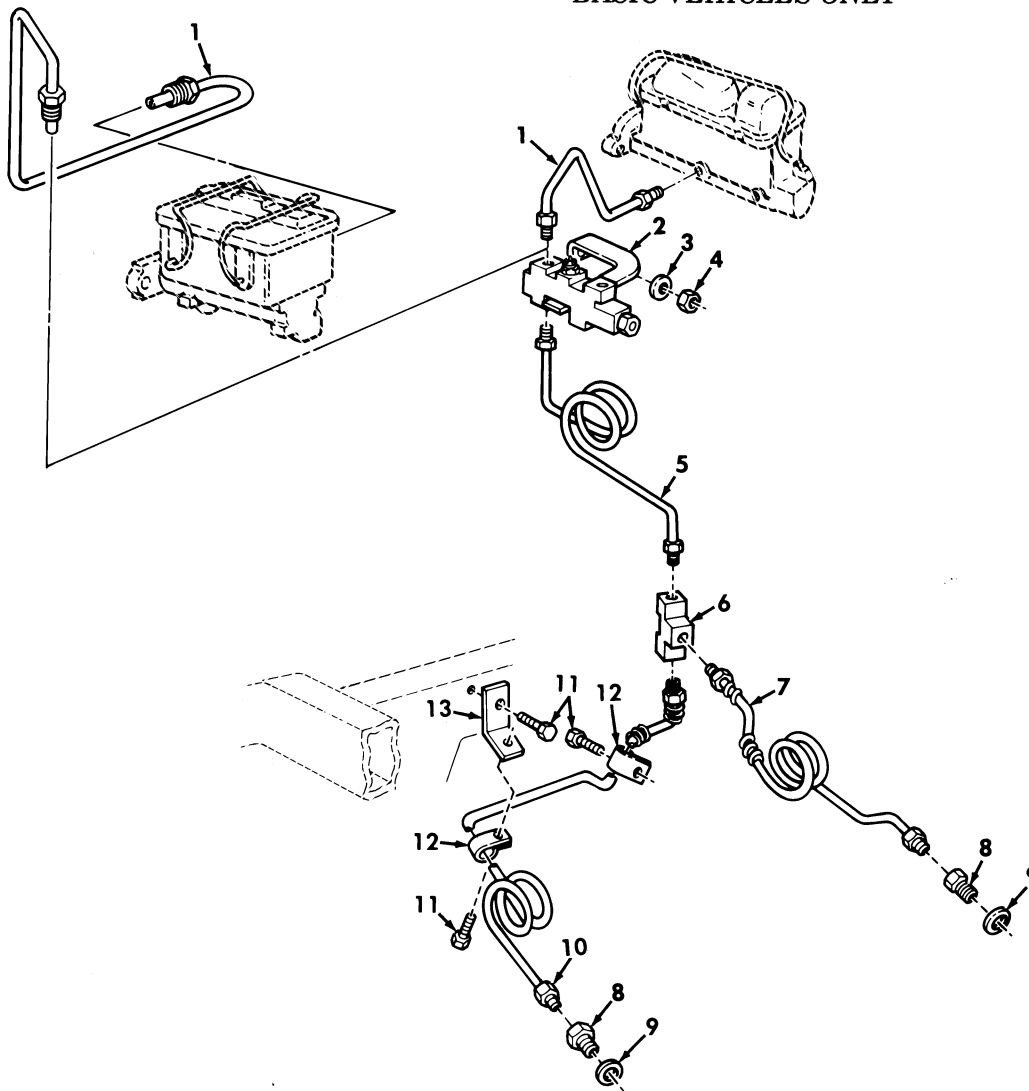

Figure 159. Front Service Brake Lines and Proportioning Valve.

SECTION II			TM9-2320-280-24P			
(1)	(2)	(3)	(4)	(5)	(6)	(7)
ITEM NO	SMR CODE	NSN	CAGEC	PART NUMBER	DESCRIPTION AND USABLE ON CODES(UOC)	QTY
GROUP 1204 HYDRAULIC BRAKE SYSTEM						
FIG. 159 FRONT SERVICE BRAKE LINES AND PROPORTIONING VALVE						
1	PAOZZ	4710013581943	19207	12342900	TUBE ASSEMBLY,METAL..... UOC:AVY,A11,A13,A14,A15,A20,A24,A25,A26,A27,B16,B17,B18,HVY	1
1	PAOZZ	4710011859666	34623	5578916	TUBE ASSEMBLY,METAL..... UOC:H11,H13,H14,H15,H16,H17,H18,H20,H21,H24,H25,H26,H27,H28,MMM	1
2	PAOZZ	4820013599489	19207	12339353-1	VALVE,REGULATING,FL..... UOC:AVY,A11,A13,A14,A15,A20,A24,A25,A26,A27,B16,B17,B18,HVY	1
2	PAOZZ	4820011860822	34281	109413-01	VALVE,REGULATING,FL..... UOC:H11,H13,H14,H15,H16,H17,H18,H20,H21,H24,H25,H26,H27,H28,MMM	1
3	PAOZZ	5310000877493	96906	MS27183-13	WASHER,FLAT 3/8..... UOC:AVY,A11,A13,A14,A15,A20,A24,A25,A26,A27,B16,B17,B18,HVY,H11,H13,H14,H15,H16,H17,H18,H20,H21,H24,H25,H26,H27,H28,MMM	1
4	PAOZZ	5310009359021	96906	MS51943-35	NUT,SELF-LOCKING,HE 3/8-16..... UOC:AVY,A11,A13,A14,A15,A20,A24,A25,A26,A27,B16,B17,B18,HVY,H11,H13,H14,H15,H16,H17,H18,H20,H21,H24,H25,H26,H27,H28,MMM	1
5	PAOZZ	4710011859667	19207	12338306	TUBE ASSEMBLY,METAL..... UOC:AVY,A11,A13,A14,A15,A20,A24,A25,A26,A27,B16,B17,B18,HVY,H11,H13,H14,H15,H16,H17,H18,H20,H21,H24,H25,H26,H27,H28,MMM	1
6	PAOZZ	4730002871706	7X677	178654	TEE,TUBE..... UOC:AVY,A11,A13,A14,A15,A20,A24,A25,A26,A27,B16,B17,B18,HVY,H11,H13,H14,H15,H16,H17,H18,H20,H21,H24,H25,H26,H27,H28,MMM	1
7	PAOZZ	4710011859668	34623	12338296	TUBE ASSEMBLY,METAL FRONT,L.H..... UOC:AVY,A11,A13,A14,A15,A20,A24,A25,A26,A27,B16,B17,B18,HVY,H11,H13,H14,H15,H16,H17,H18,H20,H21,H24,H25,H26,H27,H28,MMM	1
8	PAOZZ	4730011846971	01989	112-06136	COUPLING,TUBE..... UOC:AVY,A11,A13,A14,A15,A20,A24,A25,A26,A27,B16,B17,B18,HVY,H11,H13,H14,H15,H16,H17,H18,H20,H21,H24,H25,H26,H27,H28,MMM	2
9	PAOZZ	5310011898476	34623	5582366	WASHER,FLAT 25/64..... UOC:AVY,A11,A13,A14,A15,A20,A24,A25,A26,A27,B16,B17,B18,HVY,H11,H13,H14,H15,H16,H17,H18,H20,H21,H24,H25,H26,H27,H28,MMM	2
10	PAOZZ	4710011861016	34623	5584142	TUBE ASSEMBLY,METAL FRONT,RH.....	1

SECTION II			TM9-2320-280-24P			
(1)	(2)	(3)	(4)	(5)	(6)	(7)
ITEM NO	SMR CODE	NSN	CAGEC	PART NUMBER	DESCRIPTION AND USABLE ON CODES(UOC)	QTY
11	PAOZZ	5305000518605	80205	MS16995-77	UOC:AVY,A11,A13,A14,A15,A20,A24,A25,A26,A27,B15,B16,B17,B18,B20,B24,B25,C17,HVY,H11,H13,H14,H15,H16,H17,H18,H20,H24,MMM SCREW,CAP,SOCKET HE 3/8-19 X 1/2...	3
12	PAOZZ	5340009546014	96906	MS21333-121	UOC:AVY,A11,A13,A14,A15,A20,A24,A25,A26,A27,B16,B17,B18,HVY,H11,H13,H14,H15,H16,H17,H18,H20,H21,H24,H25,H26,H27,H28,MMM CLAMP,LOOP.....	2
13	PFOZZ	5340012097795	19207	12338301	UOC:AVY,A11,A13,A14,A15,A20,A24,A25,A26,A27,B16,B17,B18,HVY,H11,H13,H14,H15,H16,H17,H18,H20,H21,H24,H25,H26,H27,H28,MMM BRACKET,ANGLE.....	1

END OF FIGURE

**USE WITH A2 VEHICLES**

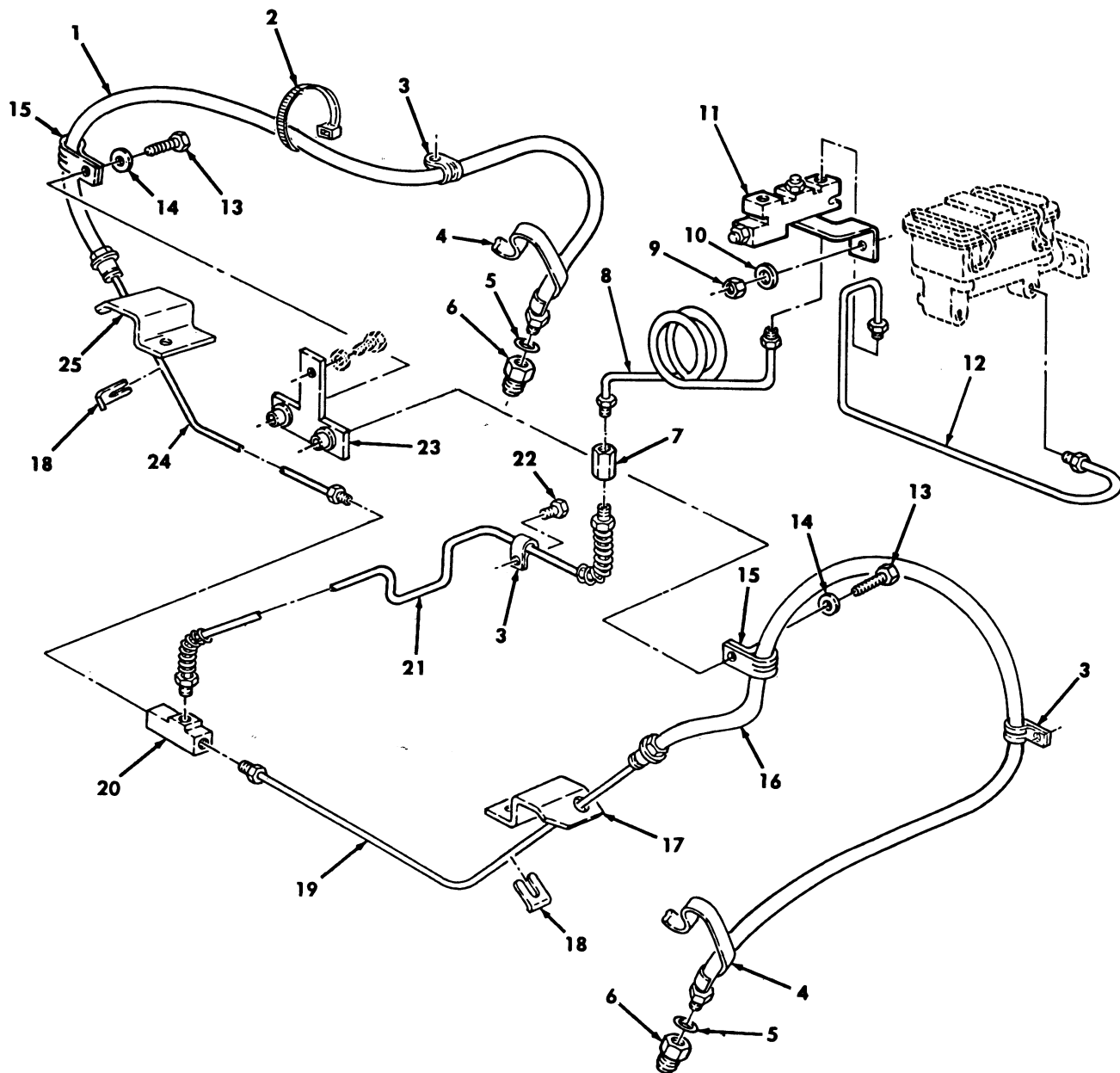

*Figure 160. Front Service Brake Lines and Proportioning Valve.*

SECTION II			TM9-2320-280-24P			
(1)	(2)	(3)	(4)	(5)	(6)	(7)
ITEM	SMR			PART		
NO	CODE	NSN	CAGEC	NUMBER	DESCRIPTION AND USABLE ON CODES(UOC)	QTY
GROUP 1204 HYDRAULIC BRAKE SYSTEM						
FIG. 160 FRONT SERVICE BRAKE LINES AND PROPORTIONING VALVE						
1	PAOZZ	4720014433033	34623	RCSK18434-3	HOSE ASSEMBLY, NONME L.H.....	2
					UOC: BVY, B15, B20, B24, B25, C17, NNN	
1	PAOZZ	4720014429875	34623	RCSK18434-2	HOSE ASSEMBLY, NONME R.H.....	1
					UOC: BVY, B15, B20, B24, B25, C17, NNN	
2	PAOZZ	5975009846582	96906	MS3367-1-0	STRAP, TIEDOWN, ELECT.....	1
					UOC: BVY, B15, B20, B24, B25, C17, NNN	
3	PAOZZ	5340009546014	96906	MS21333-121	CLAMP, LOOP.....	1
					UOC: BVY, B15, B20, B24, B25, C17, NNN	
4	MOOZZ		34623	RCSK17805	PROTECTIVE COATING MAKE FROM TUBING, P/N B47287-II-1/2, LENGTH TO SUIT.....	1
					UOC: BVY, B15, B20, B24, B25, C17, NNN	
5	PAOZZ	5310011898476	34623	5582366	WASHER, FLAT 25/64.....	2
					UOC: BVY, B15, B20, B24, B25, C17, NNN	
6	PAOZZ	4730011846971	34623	12339235	COUPLING, TUBE.....	2
					UOC: BVY, B15, B20, B24, B25, C17, NNN	
7	PAOZZ	4730014570727	72582	442393	COUPLING, HOSE.....	1
					UOC: BVY, B15, B20, B24, B25, C17, NNN	
8	PAOZZ	4710011859667	34623	5584146	TUBE ASSEMBLY, METAL.....	1
					UOC: BVY, B15, B20, B24, B25, C17, NNN	
9	PAOZZ	5310009359021	96906	MS51943-35	NUT, SELF-LOCKING, HE.....	1
					UOC: BVY, B15, B20, B24, B25, C17, NNN	
10	PAOZZ	5310000877493	96906	MS27183-13	WASHER, FLAT.....	1
					UOC: BVY, B15, B20, B24, B25, C17, NNN	
11	PAOZZ	4820013599489	34623	12339353-1	VALVE, REGULATING, FL.....	2
					UOC: BVY, B15, B20, B24, B25, C17, NNN	
12	PAOZZ	4710013581943	19207	12342900	TUBE ASSEMBLY, METAL.....	1
					UOC: BVY, B15, B20, B24, B25, C17, NNN	
13	PAOZZ	5306002264828	80204	B1821BH031C113N	BOLT, MACHINE 5/16-18 X 1.13.....	2
					UOC: BVY, B15, B20, B24, B25, C17, NNN	
14	PAOZZ	5310000814219	96906	MS27183-12	WASHER, FLAT.....	2
					UOC: BVY, B15, B20, B24, B25, C17, NNN	
15	PAOZZ	5340000573043	96906	MS21333-112	CLAMP, LOOP.....	2
					UOC: BVY, B15, B20, B24, B25, C17, NNN	
16	PAOZZ	4720014433033	34623	RCSK18434-3	HOSE ASSEMBLY, NONME.....	1
					UOC: BVY, B15, B20, B24, B25, C17, NNN	
17	PFOZA	5340014348109	34623	EX4228-2	BRACKET, MULTIPLE AN.....	1
					UOC: BVY, B15, B20, B24, B25, C17, NNN	
18	PAOZZ	5342006781753	19207	7331407	CLIP, HAND BRAKE CAB.....	2
					UOC: BVY, B15, B20, B24, B25, C17, NNN	
19	PAOZZ	4710014343151	34623	EX4231-3	TUBE ASSEMBLY, METAL.....	1
					UOC: BVY, B15, B20, B24, B25, C17, NNN	
20	PAOZZ	4730002871706	7X677	178654	TEE, TUBE.....	1
					UOC: BVY, B15, B20, B24, B25, C17, NNN	
21	PAOZZ	4710014343037	34623	EX4233	TUBE ASSEMBLY, METAL.....	1
					UOC: BVY, B15, B20, B24, B25, C17, NNN	
22	PAOZZ	5305013936311	24617	271153	SCREW, TAPPING.....	1
					UOC: BVY, B15, B20, B24, B25, C17, NNN	

SECTION II			TM9-2320-280-24P			
(1)	(2)	(3)	(4)	(5)	(6)	(7)
ITEM	SMR			PART		
NO	CODE	NSN	CAGEC	NUMBER	DESCRIPTION AND USABLE ON CODES(UC)	QTY
23	PAOZZ	5340014588236	34623	EX4718	BRACKET,T.....	1
					UOC:BVY,B15,B20,B24,B25,C17,NNN	
24	PAOZZ	4710014343157	34623	EX4231-4	TUBE ASSEMBLY,METAL.....	1
					UOC:BVY,B15,B20,B24,B25,C17,NNN	
25	PAOZZ	5340014328681	34623	EX4228-1	BRACKET,MULTIPLE AN.....	1
					UOC:BVY,B15,B20,B24,B25,C17,NNN	

END OF FIGURE





SECTION II			TM9-2320-280-24P			
(1)	(2)	(3)	(4)	(5)	(6)	(7)
ITEM NO	SMR CODE	NSN	CAGEC	PART NUMBER	DESCRIPTION AND USABLE ON CODES(UOC)	QTY
GROUP 1204 HYDRAULIC BRAKE SYSTEM						
FIG. 161 REAR BRAKE LINES AND FITTINGS						
1	PFOZZ	5340012097796	19207	12338302	BRACKET,ANGLE..... UOC:AVY,A11,A13,A14,A15,A20,A24,A25, A26,A27,B16,B17,B18,HVY,H11,H13,H14, H15,H16,H17,H18,H20,H21,H24,H25,H26, H27,H28,MMM	1
2	PAOZZ	5340011897640	7X677	179148	CLAMP,LOOP REAR..... UOC:AVY,A11,A13,A14,A15,A20,A24,A25, A26,A27,B16,B17,B18,HVY,H11,H13,H14, H15,H16,H17,H18,H20,H21,H24,H25,H26, H27,H28,MMM	7
3	PAOZZ	4710011892209	19207	12338308	TUBE ASSEMBLY,METAL..... UOC:AVY,A11,A13,A14,A15,A20,A24,A25, A26,A27,B16,B17,B18,HVY,H11,H13,H14, H15,H16,H17,H18,H20,H21,H24,H25,H26, H27,H28,MMM	1
4	PAOZZ	5305000518605	80205	MS16995-77	SCREW,CAP,SOCKET HE 3/8-16 X 1/2... UOC:AVY,A11,A13,A14,A15,A20,A24,A25, A26,A27,B16,B17,B18,HVY,H11,H13,H14, H15,H16,H17,H18,H20,H21,H24,H25,H26, H27,H28,MMM	9
5	PAOZZ	4710011869620	19207	12338307	TUBE ASSEMBLY,METAL..... UOC:AVY,A11,A13,A14,A15,A20,A24,A25, A26,A27,B16,B17,B18,HVY,H11,H13,H14, H15,H16,H17,H18,H20,H21,H24,H25,H26, H27,H28,MMM	1
6	PAOZZ	4710013579968	19207	12342901	TUBE ASSEMBLY,METAL..... UOC:AVY,A11,A13,A14,A15,A20,A24,A25, A26,A27,B16,B17,B18,HVY	1
6	PAOZZ	4710011859665	19207	12338300	TUBE ASSEMBLY,METAL..... UOC:H11,H13,H14,H15,H16,H17,H18,H20, H21,H24,H25,H26,H27,H28,MMM	1
7	PAOZZ	4730014570727	72582	442393	COUPLING,HOSE REAR..... UOC:AVY,A11,A13,A14,A15,A20,A24,A25, A26,A27,B16,B17,B18,HVY,H11,H13,H14, H15,H16,H17,H18,H20,H21,H24,H25,H26, H27,H28,MMM	2
8	PAOZZ	4710011858329	19207	12338305	TUBE ASSEMBLY,METAL REAR,LH..... UOC:AVY,A11,A13,A14,A15,A20,A24,A25, A26,A27,B16,B17,B18,HVY,H11,H13,H14, H15,H16,H17,H18,H20,H21,H24,H25,H26, H27,H28,MMM	1
9	PAOZZ	4730011846971	01989	112-06136	COUPLING,TUBE..... UOC:AVY,A11,A13,A14,A15,A20,A24,A25, A26,A27,B16,B17,B18,HVY,H11,H13,H14, H15,H16,H17,H18,H20,H21,H24,H25,H26, H27,H28,MMM	2
10	PAOZZ	5310011898476	34623	5582366	WASHER,FLAT 25/64..... UOC:AVY,A11,A13,A14,A15,A20,A24,A25,	2

SECTION II			TM9-2320-280-24P			
(1)	(2)	(3)	(4)	(5)	(6)	(7)
ITEM	SMR			PART		
NO	CODE	NSN	CAGEC	NUMBER	DESCRIPTION AND USABLE ON CODES(UC)	QTY
11	PAOZZ	4710011892208	19207	12338304	A26,A27,B16,B17,B18,HVY,H11,H13,H14, H15,H16,H17,H18,H20,H21,H24,H25,H26, H27,H28,MMM TUBE ASSEMBLY,METAL.....	1
					UOC:AVY,A11,A13,A14,A15,A20,A24,A25, A26,A27,B16,B17,B18,HVY,H11,H13,H14, H15,H16,H17,H18,H20,H21,H24,H25,H26, H27,H28,MMM	
12	PAOZZ	5340009546014	96906	MS21333-121	CLAMP,LOOP REAR.....	2
					UOC:AVY,A11,A13,A14,A15,A20,A24,A25, A26,A27,B16,B17,B18,HVY,H11,H13,H14, H15,H16,H17,H18,H20,H21,H24,H25,H26, H27,H28,MMM	
13	PAOZZ	4710011858328	19207	12338298	TUBE ASSEMBLY,METAL REAR,RH.....	1
					UOC:AVY,A11,A13,A14,A15,A20,A24,A25, A26,A27,B16,B17,B18,HVY,H11,H13,H14, H15,H16,H17,H18,H20,H21,H24,H25,H26, H27,H28,MMM	
14	PAOZZ	4730002871706	7X677	178654	TEE,TUBE REAR.....	1
					UOC:AVY,A11,A13,A14,A15,A20,A24,A25, A26,A27,B16,B17,B18,HVY,H11,H13,H14, H15,H16,H17,H18,H20,H21,H24,H25,H26, H27,H28,MMM	

END OF FIGURE

**USE WITH A2 VEHICLES ONLY**

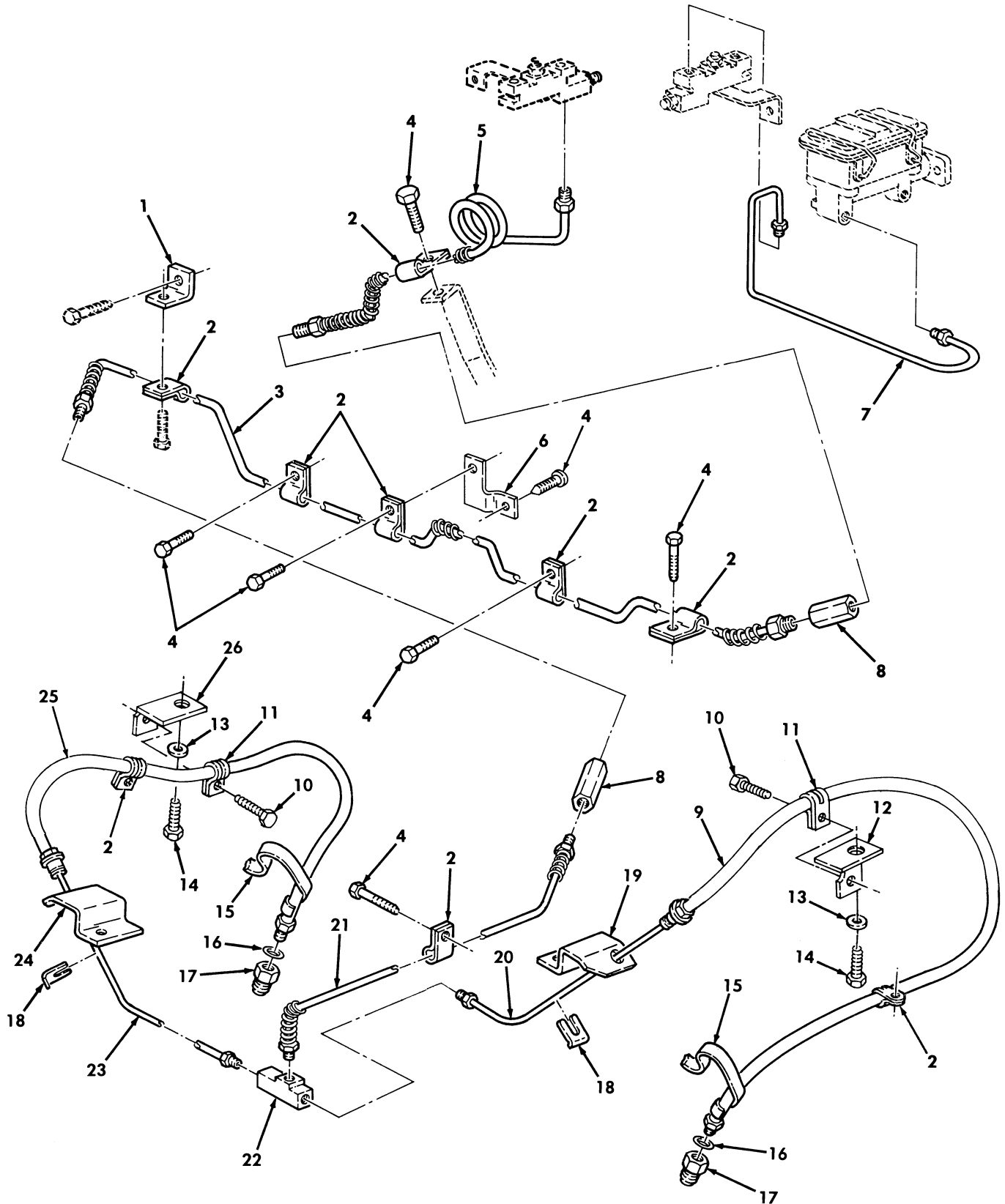

Figure 162. Rear Brake Lines and Fittings.

SECTION II			TM9-2320-280-24P			
(1)	(2)	(3)	(4)	(5)	(6)	(7)
ITEM	SMR			PART		
NO	CODE	NSN	CAGEC	NUMBER	DESCRIPTION AND USABLE ON CODES(UOC)	QTY
GROUP 1204 HYDRAULIC BRAKE SYSTEM						
FIG. 162 REAR BRAKE LINES AND FITTINGS						
1	PFOZZ	5340012097796	19207	12338302	BRACKET,ANGLE.....	1
					UOC:BVY,B15,B20,B24,B25,C17,NNN	
2	PAOZZ	5340011897640	7X677	179148	CLAMP,LOOP.....	6
					UOC:BVY,B15,B20,B24,B25,C17,NNN	
3	PAOZZ	4710014138230	34623	12447166	TUBE ASSEMBLY,METAL.....	1
					UOC:BVY,B15,B20,B24,B25,C17,NNN	
4	PAOZZ	5305000518605	80205	MS16995-77	SCREW,CAP, SOCKET HE.....	6
					UOC:BVY,B15,B20,B24,B25,C17,NNN	
5	PAOZZ	4710011869620	19207	12338307	TUBE ASSEMBLY,METAL.....	1
					UOC:BVY,B15,B20,B24,B25,C17,NNN	
6	PAOZZ	5340014120867	19207	12447165	BRACKET,MOUNTING.....	1
					UOC:BVY,B15,B20,B24,B25,C17,NNN	
7	PAOZZ	4720014562955	34623	EX4786-4	HOSE ASSEMBLY, NONME.....	1
					UOC:BVY,B15,B20,B24,B25,C17,NNN	
8	PAOZZ	4730014570727	72582	442393	COUPLING,HOSE.....	1
					UOC:BVY,B15,B20,B24,B25,C17,NNN	
9	PAOZZ	4720014433481	34623	RCSK18435-3	HOSE ASSEMBLY, NONME L.H.....	1
					UOC:BVY,B15,B20,B24,B25,C17,NNN	
10	PAOZZ	5305013936311	24617	271153	SCREW,TAPPING 3/8-16 X .63.....	7
					UOC:BVY,B15,B20,B24,B25,C17,NNN	
11	PAOZZ	5340000573043	96906	MS21333-112	CLAMP,LOOP.....	2
					UOC:BVY,B15,B20,B24,B25,C17,NNN	
12	PAOZZ	5340014587156	34623	EX4717-1	BRACKET,ANGLE L.H.....	1
					UOC:BVY,B15,B20,B24,B25,C17,NNN	
13	PAOZZ	5310000814219	96906	MS27183-12	WASHER,FLAT.....	2
					UOC:BVY,B15,B20,B24,B25,C17,NNN	
14	PAOZZ	5306002264828	80204	B1821BH031C113N	BOLT,MACHINE 5/16-18 X 1.13.....	2
					UOC:BVY,B15,B20,B24,B25,C17,NNN	
15	MOOZZ		81349	B47287-II-1/2-27	TUBING,PLASTIC, SPIR MAKE FROM	2
					TUBING,P/N B47287-II-1/2,27 INCHES	
					LONG.....	
					UOC:BVY,B15,B20,B24,B25,C17,NNN	
16	PAOZZ	5310011898476	34623	5582366	WASHER,FLAT 25/64.....	1
					UOC:BVY,B15,B20,B24,B25,C17,NNN	
17	PAOZZ	4730011846971	34623	12339235	COUPLING,TUBE.....	2
					UOC:BVY,B15,B20,B24,B25,C17,NNN	
18	PAOZZ	5342006781753	19207	7331407	CLIP,HAND BRAKE CAB.....	2
					UOC:BVY,B15,B20,B24,B25,C17,NNN	
19	PFOZZ	5340014328681	34623	EX4228-1	BRACKET,MULTIPLE AN.....	1
					UOC:BVY,B15,B20,B24,B25,C17,NNN	
20	PAOZZ	4710014343151	34623	EX4231-3	TUBE ASSEMBLY,METAL.....	1
					UOC:BVY,B15,B20,B24,B25,C17,NNN	
21	PAOZZ	4710014343159	34623	EX4234	TUBE ASSEMBLY,METAL.....	1
					UOC:BVY,B15,B20,B24,B25,C17,NNN	
22	PAOZZ	4730002871706	7X677	178654	TEE,TUBE.....	1
					UOC:BVY,B15,B20,B24,B25,C17,NNN	
23	PAOZZ	4710014343157	34623	EX4231-4	TUBE ASSEMBLY,METAL.....	1
					UOC:BVY,B15,B20,B24,B25,C17,NNN	

SECTION II			TM9-2320-280-24P			
(1)	(2)	(3)	(4)	(5)	(6)	(7)
ITEM	SMR			PART		
NO	CODE	NSN	CAGEC	NUMBER	DESCRIPTION AND USABLE ON CODES(UC)	QTY
24	PAOZZ	5340014348109	34623	EX4228-2	BRACKET,MULTIPLE AN.....	1
					UOC:BVY,B15,B20,B24,B25,C17,NNN	
25	PAOZZ	4720014438487	34623	RCSK18435-2	HOSE ASSEMBLY,NONME R.H.....	1
					UOC:BVY,B15,B20,B24,B25,C17,NNN	
26	PAOZZ	5340014587147	34623	EX4717-2	BRACKET,ANGLE R.H.....	1
					UOC:BVY,B15,B20,B24,B25,C17,NNN	

END OF FIGURE



SECTION II			TM9-2320-280-24P			
(1)	(2)	(3)	(4)	(5)	(6)	(7)
ITEM	SMR			PART		
NO	CODE	NSN	CAGEC	NUMBER	DESCRIPTION AND USABLE ON CODES(UOC)	QTY
GROUP 1204 HYDRAULIC BRAKE SYSTEM						
FIG. 163 MASTER CYLINDER ASSEMBLY						
1	PAOZZ	2530011797589	14894	2232134	CYLINDER, HYDRAULIC.....	1
					UOC:H11, H13, H14, H15, H16, H17, H18, H20, H21, H24, H25, H26, H27, H28, MMM	
2	PAOZZ	5340012935558	73370	2230648	. CLIP, RETAINING.....	1
					UOC:H11, H13, H14, H15, H16, H17, H18, H20, H21, H24, H25, H26, H27, H28, MMM	
3	XAOZZ		73370	2232146	. COVER, RESERVOIR.....	1
					UOC:H11, H13, H14, H15, H16, H17, H18, H20, H21, H24, H25, H26, H27, H28, MMM	
4	PAOZZ	5330012935345	73370	2229379	. GASKET.....	1
					UOC:H11, H13, H14, H15, H16, H17, H18, H20, H21, H24, H25, H26, H27, H28, MMM	
5	PAOZZ	5310011730941	14892	129599	NUT, SELF-LOCKING, HE 3/8-16.....	2
					UOC:H11, H13, H14, H15, H16, H17, H18, H20, H21, H24, H25, H26, H27, H28, MMM	
6	PAOZZ	5310000806004	96906	MS27183-14	WASHER, FLAT 3/8.....	2
					UOC:AVY, A11, A13, A14, A15, A20, A24, A25, A26, A27, BVY, B15, B16, B17, B18, B20, B24, B25, C17, HVY, NNN	
7	PAOOO	2530013579776	34623	12342898	CYLINDER ASSEMBLY, H.....	1
					UOC:AVY, A11, A13, A14, A15, A20, A24, A25, A26, A27, BVY, B15, B16, B17, B18, B20, B24, B25, C17, HVY, NNN	
8	PAOZA	5340014586386	0GE52	2227677	. CLIP, RETAINING.....	2
					UOC:AVY, A11, A13, A14, A15, A20, A24, A25, A26, A27, BVY, B15, B16, B17, B18, B20, B24, B25, C17, HVY, NNN	
9	PAOZZ	5340014562751	0GE52	2227346	. COVER, PROTECTIVE, DU.....	1
					UOC:AVY, A11, A13, A14, A15, A20, A24, A25, A26, A27, BVY, B15, B16, B17, B18, B20, B24, B25, C17, HVY, NNN	
10	PAOZZ	2530014595890	0GE52	2228633	. DIAPHRAGM, MASTER CY.....	1
					UOC:AVY, A11, A13, A14, A15, A20, A24, A25, A26, A27, BVY, B15, B16, B17, B18, B20, B24, B25, C17, HVY, NNN	
11	PAOZZ	5331001716649	96906	MS28775-223	O-RING.....	1

END OF FIGURE

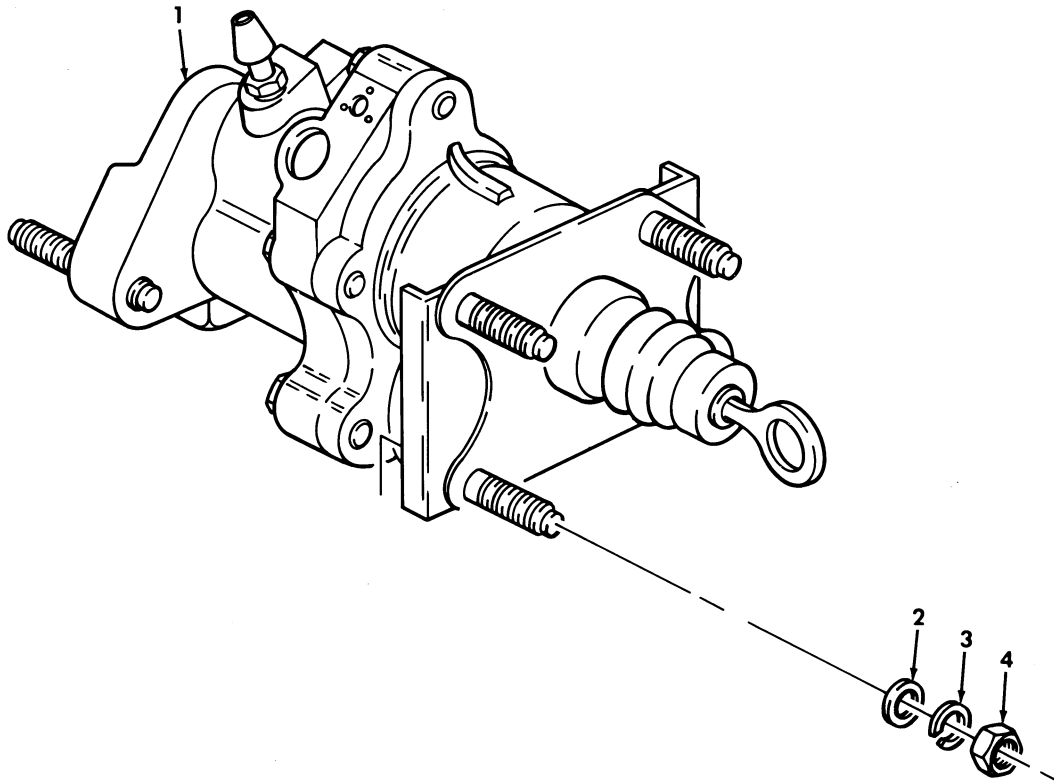

Figure 164. Hydro-Booster.



SECTION II			TM9-2320-280-24P			
(1)	(2)	(3)	(4)	(5)	(6)	(7)
ITEM	SMR			PART		
NO	CODE	NSN	CAGEC	NUMBER	DESCRIPTION AND USABLE ON CODES(UOC)	QTY
GROUP 1205 VACUUM SYSTEM COMPONENTS						
FIG. 164 HYDRO-BOOSTER						
1	PAOZZ	2530013579708	34623	5939396	BRAKE BOOSTER ASSEM..... UOC:AVY,A11,A13,A14,A15,A20,A24,A25, A26,A27,BVY,B15,B16,B17,B18,B20,B24, B25,C17,HVY,NNN	1
1	PAOZZ	2530011797590	14892	2771302	CYLINDER ASSEMBLY,H..... UOC:H11,H13,H14,H15,H16,H17,H18,H20, H21,H24,H25,H26,H27,H28,MMM	1
2	PAOZZ	5310000806004	96906	MS27183-14	WASHER,FLAT 3/8..... UOC:AVY,A11,A13,A14,A15,A20,A24,A25, A26,A27,B16,B17,B18,HVY,H11,H13,H14, H15,H16,H17,H18,H20,H21,H24,H25,H26, H27,H28,MMM	4
2	PAOZZ	5310012552704	19207	7982843	WASHER,FLAT 3/8..... UOC:BVY,B15,B20,B24,B25,C17,NNN	4
3	PAOZZ	5310000115093	96906	MS35338-65	WASHER,LOCK 3/8..... UOC:AVY,A11,A13,A14,A15,A20,A24,A25, A26,A27,B16,B17,B18,HVY,H11,H13,H14, H15,H16,H17,H18,H20,H21,H24,H25,H26, H27,H28,MMM	4
3	PAOZZ	5310006379541	96906	MS35338-46	WASHER,LOCK 3/8..... UOC:BVY,B15,B20,B24,B25,C17,NNN	4
4	PAOZZ	5310009359021	96906	MS51943-35	NUT,SELF-LOCKING,HE 3/8-16..... UOC:BVY,B15,B20,B24,B25,C17,NNN	4

END OF FIGURE

**USE WITH BASIC AND A1 VEHICLES**

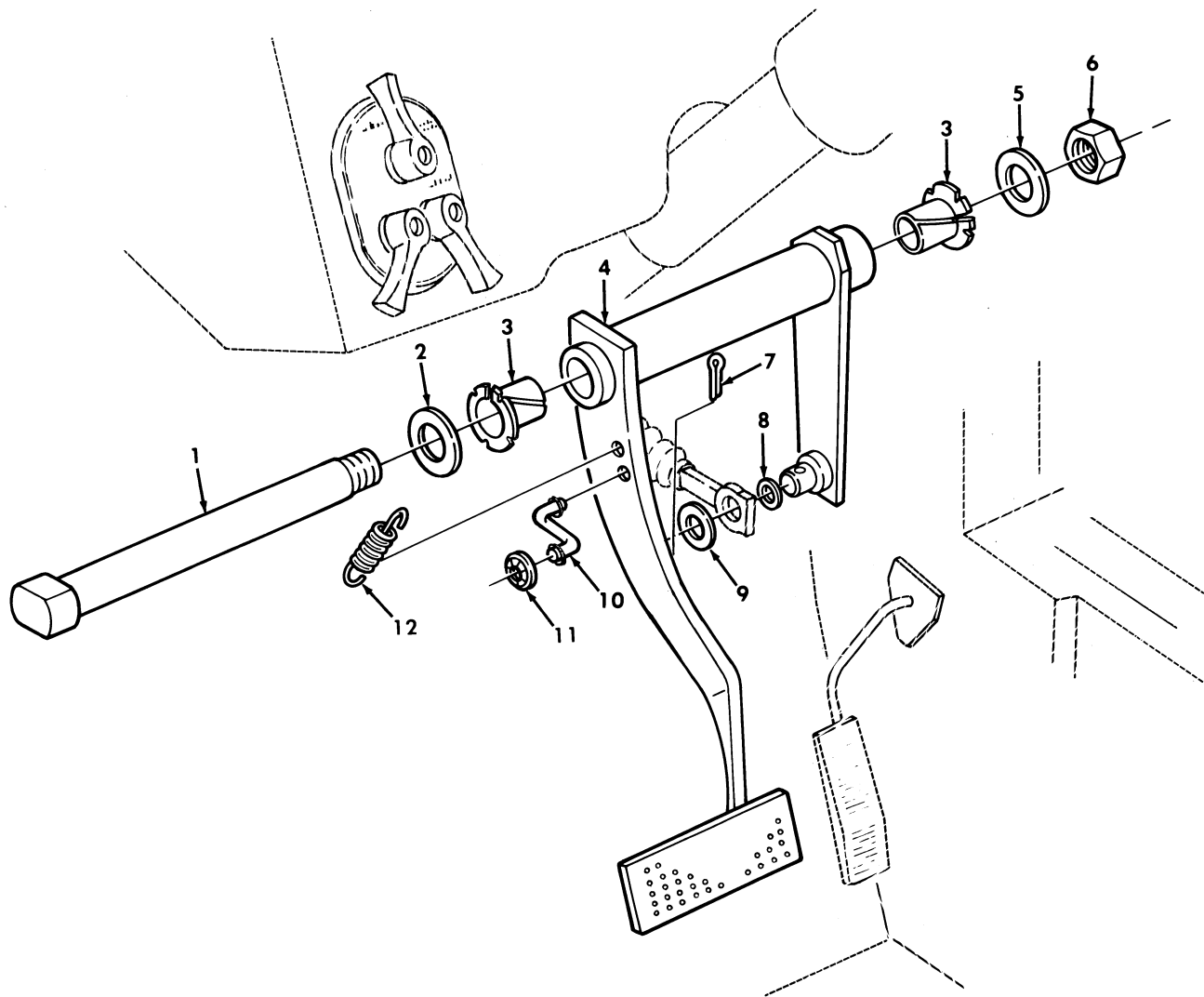

*Figure 165. Service Brake Pedal Assembly.*

SECTION II			TM9-2320-280-24P			
(1)	(2)	(3)	(4)	(5)	(6)	(7)
ITEM NO	SMR CODE	NSN	CAGEC	PART NUMBER	DESCRIPTION AND USABLE ON CODES(UC)	QTY
GROUP 1206 MECHANICAL BRAKE SYSTEM						
FIG. 165 SERVICE BRAKE PEDAL ASSEMBLY						
1	PAOZZ	5315011858781	19207	12339114	PIN, SHOULDER, HEADED..... UC:AVY, A11, A13, A14, A15, A20, A24, A25, A26, A27, B16, B17, B18, HVY, H11, H13, H14, H15, H16, H17, H18, H20, H21, H24, H25, H26, H27, H28, MMM	1
2	PAOZZ	5310012604839	34623	5593312	WASHER, FLAT 3/4..... UC:AVY, A11, A13, A14, A15, A20, A24, A25, A26, A27, B16, B17, B18, HVY, H11, H13, H14, H15, H16, H17, H18, H20, H21, H24, H25, H26, H27, H28, MMM	1
3	PAOZZ	3120004851017	96881	12L18F	BEARING, SLEEVE..... UC:AVY, A11, A13, A14, A15, A20, A24, A25, A26, A27, B16, B17, B18, HVY, H11, H13, H14, H15, H16, H17, H18, H20, H21, H24, H25, H26, H27, H28, MMM	2
4	PAOZZ	2540011844389	19207	12338394	PEDAL, CONTROL..... UC:AVY, A11, A13, A14, A15, A20, A24, A25, A26, A27, B16, B17, B18, HVY, H11, H13, H14, H15, H16, H17, H18, H20, H21, H24, H25, H26, H27, H28, MMM	1
5	PAOZZ	5310000685285	96906	MS27183-20	WASHER, FLAT 9/16..... UC:AVY, A11, A13, A14, A15, A20, A24, A25, A26, A27, B16, B17, B18, HVY, H11, H13, H14, H15, H16, H17, H18, H20, H21, H24, H25, H26, H27, H28, MMM	1
6	PAOZZ	5310007638919	96906	MS51967-18	NUT, PLAIN, HEXAGON 9/16-12..... UC:AVY, A11, A13, A14, A15, A20, A24, A25, A26, A27, B16, B17, B18, HVY, H11, H13, H14, H15, H16, H17, H18, H20, H21, H24, H25, H26, H27, H28, MMM	1
7	PAOZZ	5315008161794	00198	PK379	PIN, COTTER 3/32 X 1.00..... UC:AVY, A11, A13, A14, A15, A20, A24, A25, A26, A27, B16, B17, B18, HVY, H11, H13, H14, H15, H16, H17, H18, H20, H21, H24, H25, H26, H27, H28, MMM	1
8	PAOZZ	5310011898485	92871	4004616	WASHER, SPRING TENSI 1/2..... UC:AVY, A11, A13, A14, A15, A20, A24, A25, A26, A27, B16, B17, B18, HVY, H11, H13, H14, H15, H16, H17, H18, H20, H21, H24, H25, H26, H27, H28, MMM	1
9	PAOZZ	5310008095998	96906	MS27183-18	WASHER, FLAT 1/2..... UC:AVY, A11, A13, A14, A15, A20, A24, A25, A26, A27, B16, B17, B18, HVY, H11, H13, H14, H15, H16, H17, H18, H20, H21, H24, H25, H26, H27, H28, MMM	1
10	PAOZZ	3040011860967	19207	12338390	CONNECTING LINK, RIG..... UC:AVY, A11, A13, A14, A15, A20, A24, A25, A26, A27, B16, B17, B18, HVY, H11, H13, H14,	1

SECTION II			TM9-2320-280-24P			
(1)	(2)	(3)	(4)	(5)	(6)	(7)
ITEM	SMR			PART		
NO	CODE	NSN	CAGEC	NUMBER	DESCRIPTION AND USABLE ON CODES(UC)	QTY
11	PAOZZ	5310011886861	19207	12339313	H15,H16,H17,H18,H20,H21,H24,H25,H26, H27,H28,MMM PUSH ON NUT 3/16.....	2
					UOC:AVY,A11,A13,A14,A15,A20,A24,A25, A26,A27,B16,B17,B18,HVY,H11,H13,H14, H15,H16,H17,H18,H20,H21,H24,H25,H26, H27,H28,MMM	
12	PAOZZ	5360011864845	34623	5578667	SPRING,HELICAL,EXTE.....	1
					UOC:AVY,A11,A13,A14,A15,A20,A24,A25, A26,A27,B16,B17,B18,HVY,H11,H13,H14, H15,H16,H17,H18,H20,H21,H24,H25,H26, H27,H28,MMM	

END OF FIGURE

**USE WITH A2 VEHICLES**

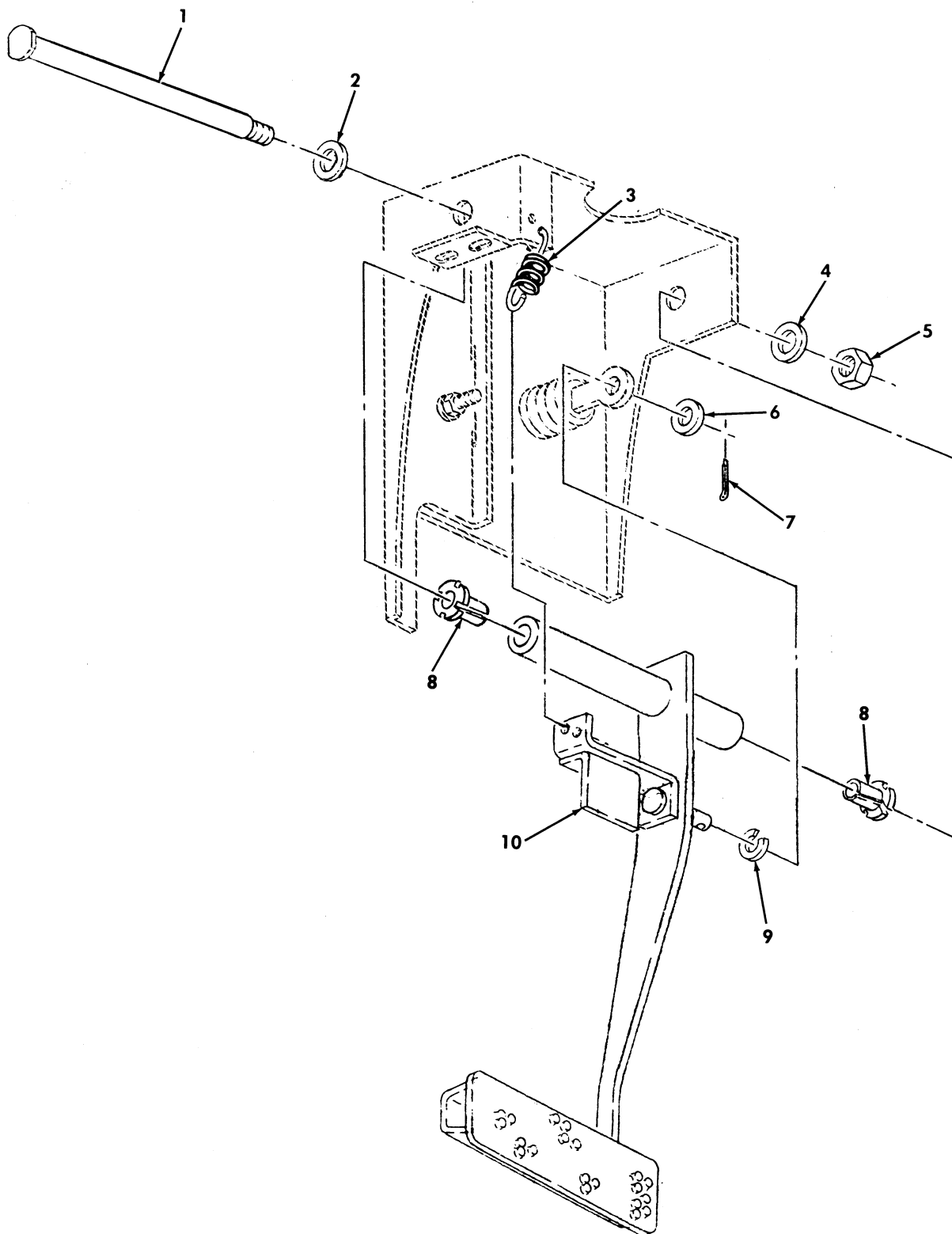

*Figure 166. Service Brake Pedal Assembly.*

SECTION II			TM9-2320-280-24P			
(1)	(2)	(3)	(4)	(5)	(6)	(7)
ITEM	SMR			PART		
NO	CODE	NSN	CAGEC	NUMBER	DESCRIPTION AND USABLE ON CODES(UC)	QTY
GROUP 1206 MECHANICAL BRAKE SYSTEM						
FIG. 166 SERVICE BRAKE PEDAL ASSEMBLY						
1	PAOZZ	5315011858781	19207	12339114	PIN, SHOULDER, HEADED.....	1
					UOC: BVY, B15, B20, B24, B25, C17, NNN	
2	PAOZZ	5310011474052	24617	2436168	WASHER, FLAT 3/4.....	1
					UOC: BVY, B15, B20, B24, B25, C17, NNN	
3	PAOZZ	5360011864845	19207	12339183	SPRING, HELICAL, EXTE.....	1
					UOC: BVY, B15, B20, B24, B25, C17, NNN	
4	PAOZZ	5310000685285	96906	MS27183-20	WASHER, FLAT 9/16.....	1
					UOC: BVY, B15, B20, B24, B25, C17, NNN	
5	PAOZZ	5310000443342	24617	9422303	NUT, SELF-LOCKING, HE 9/16.....	1
					UOC: BVY, B15, B20, B24, B25, C17, NNN	
6	PAOZZ	5310008095998	96906	MS27183-18	WASHER, FLAT 1/2.....	1
					UOC: BVY, B15, B20, B24, B25, C17, NNN	
7	PAOZZ	5315008161794	00198	PK379	PIN, COTTER 3/32 X 1.00.....	1
					UOC: BVY, B15, B20, B24, B25, C17, NNN	
8	PAOZZ	3120004851017	19207	12339112-2	BEARING, SLEEVE.....	2
					UOC: BVY, B15, B20, B24, B25, C17, NNN	
9	PAOZZ	5310014132049	19207	12338124	WASHER, SPRING TENSI 1/2.....	1
					UOC: BVY, B15, B20, B24, B25, C17, NNN	
10	PAOZZ	2540014113946	19207	12447078	PEDAL, CONTROL.....	1
					UOC: BVY, B15, B20, B24, B25, C17, NNN	

END OF FIGURE



SECTION II			TM9-2320-280-24P			
(1)	(2)	(3)	(4)	(5)	(6)	(7)
ITEM NO	SMR CODE	NSN	CAGEC	PART NUMBER	DESCRIPTION AND USABLE ON CODES(UOC)	QTY
GROUP 13 WHEELS						
1311 WHEEL ASSEMBLY						
FIG. 167 WHEEL AND RUNFLAT ASSEMBLY						
1	AOOOO		41885	89305	WHEEL AND RUN FLAT USE WITH BIAS TIRE ONLY.....	4
					UOC:H11,H13,H14,H15,H16,H17,H18,H20,H21,H24,H25,H26,H27,H28,MMM	
2	PAOOO	2530011610006	41885	89322	.RIM,WHEEL,PNEUMATIC INNER,USE WITH BIAS TIRE ONLY.....	1
					UOC:H11,H13,H14,H15,H16,H17,H18,H20,H21,H24,H25,H26,H27,H28,MMM	
3	PAOZZ	5306011757577	34623	5578150	..BOLT,RIBBED NECK 1/2-20 X 2.00, USE WITH P/N 89322.....	8
					UOC:H11,H13,H14,H15,H16,H17,H18,H20,H21,H24,H25,H26,H27,H28,MMM	
4	PAOZZ	5331011760923	34623	5591345	.O-RING USE WITH BIAS WHEEL ONLY...	1
					UOC:H11,H13,H14,H15,H16,H17,H18,H20,H21,H24,H25,H26,H27,H28,MMM	
5	PAOFF	2640011612114	19207	12338803	.RIM,RUNFLAT USE WITH BIAS TIRE ONLY.....	2
					UOC:H11,H13,H14,H15,H16,H17,H18,H20,H21,H24,H25,H26,H27,H28,MMM	
6	PAOZZ	5310012122215	41885	89325	.NUT,SELF-LOCKING,EX 3/8-16,USE WITH BIAS WHEEL ONLY.....	4
					UOC:H11,H13,H14,H15,H16,H17,H18,H20,H21,H24,H25,H26,H27,H28,MMM	
7	PAOZZ	5310011987585	19207	12339501	.NUT,SELF-LOCKING,HE 1/2-20,USE WITH BIAS WHEEL ONLY.....	8
					UOC:H11,H13,H14,H15,H16,H17,H18,H20,H21,H24,H25,H26,H27,H28,MMM	
8	PAOZZ	2530011610005	41885	89321	.RIM,WHEEL,PNEUMATIC USE WITH BIAS TIRE ONLY.....	1
					UOC:H11,H13,H14,H15,H16,H17,H18,H20,H21,H24,H25,H26,H27,H28,MMM	
9	PAOZZ	5305012056048	41885	89324	.SCREW,CAP,HEXAGON H 3/8-16 X 1.625,USE WITH BIAS WHEEL ONLY.....	4
					UOC:H11,H13,H14,H15,H16,H17,H18,H20,H21,H24,H25,H26,H27,H28,MMM	
10	PAOZZ	5310010219027	7X677	1567442	NUT,PLAIN,CONE SEAT 9/16-18.....	32
11	PAOZZ	2640005552834	17875	T-18	VALVE,PNEUMATIC TIR USE WITH BIAS WHEEL ONLY.....	4
					UOC:H11,H13,H14,H15,H16,H17,H18,H20,H21,H24,H25,H26,H27,H28,MMM	
12	PAOZZ	2530012358688	34623	5593926	WEIGHT,WHEEL BALANC ADHESIVE.....	V
12	PAOZZ	6670012616844	34623	5595966	WEIGHT,BALANCE CLIP ON,1/2 OUNCE...	V
12	PAOZZ	2530008484581	9G287	P-100	WEIGHT,WHEEL BALANC CLIP ON,1 OUNCE	V
12	PAOZZ	6670012616845	34623	5595968	WEIGHT,BALANCE CLIP ON,1-1/2 OUNCE.	V
12	PAOZZ	6670012616846	34623	5595969	WEIGHT,BALANCE CLIP ON,2 OUNCE.....	V
12	PAOZZ	6670012628646	34623	5595970	WEIGHT,BALANCE CLIP ON,2 1/2 OUNCE.	V
12	PAOZZ	6670012618011	34623	5595971	WEIGHT,BALANCE CLIP ON,3 OUNCE.....	V
12	PAOZZ	6670012618012	34623	5595972	WEIGHT,BALANCE CLIP ON,3-1/2 OUNCE.	V



SECTION II			TM9-2320-280-24P			
(1)	(2)	(3)	(4)	(5)	(6)	(7)
ITEM NO	SMR CODE	NSN	CAGEC	PART NUMBER	DESCRIPTION AND USABLE ON CODES(UOC)	QTY
12	PAOZZ	6670012618013	34623	5595973	WEIGHT,BALANCE CLIP ON,4 OUNCE.....	V
12	PAOZZ	6670012616847	34623	5595974	WEIGHT,BALANCE CLIP ON,4-1/2 OUNCE.	V
12	PAOZZ	6670012628647	9G287	P-500	WEIGHT,BALANCE CLIP ON,5 OUNCE.....	V
12	PAOZZ	6670012632268	9G287	P-550	WEIGHT,BALANCE CLIP ON,5-1/2 OUNCE.	V
12	PAOZZ	2530012358688	34623	5593926	WEIGHT,WHEEL BALANC CLIP ON,6 OUNCE	V
13	AOOOO		19207	12460176	WHEEL AND RUNFLAT,A (3850 LB).....	4
					UOC:BVY,B15,B20,B24,B25,C17,NNN	
13	AOOOO		19207	12342641	WHEEL AND RUNFLAT,A (3400 LB).....	4
					UOC:AVY,A11,A13,A14,A15,A20,A24,A25,A26,A27,B16,B17,B18,HVY,H11,H13,H14,H15,H16,H17,H18,H20,H21,H24,H25,H26,H27,H28,MMM	
14	PAOOO	2530014174908	34623	12460177	.RIM,WHEEL,PNEUMATI INNER,(3850 LB)	1
					PART OF KIT P/N 57K3527.....	
14	PAOOO	2530013365740	19207	12342642	.RIM,WHEEL,PNEUMATI INNER,(3400 LB)	1
					UOC:AVY,A11,A13,A14,A15,A20,A24,A25,A26,A27,B16,B17,B18,HVY,H11,H13,H14,H15,H16,H17,H18,H20,H21,H24,H25,H26,H27,H28,MMM	
15	PAOZZ	5306014172467	19207	12460179	..BOLT,RIBBED NECK USE WITH RIM P/N	12
					12460177.....	
15	PAOZZ	5306013367175	41885	90297	..BOLT,RIBBED NECK 1/2-20 X 2.12,	12
					USE WITH RIM P/N 12342642,(3400 LB).	
					UOC:AVY,A11,A13,A14,A15,A20,A24,A25,A26,A27,B16,B17,B18,HVY,H11,H13,H14,H15,H16,H17,H18,H20,H21,H24,H25,H26,H27,H28,MMM	
16	PAOZZ	5331014171043	41885	91610	.O-RING USE WITH RIM P/N 12460177,	1
					PART OF KIT P/N 57K3527.....	
16	PAOZZ	5331013358878	19207	12342633	.O-RING USE WITH RIM P/N 12342642..	1
					UOC:AVY,A11,A13,A14,A15,A20,A24,A25,A26,A27,B16,B17,B18,HVY,H11,H13,H14,H15,H16,H17,H18,H20,H21,H24,H25,H26,H27,H28,MMM	
17	PAOZZ	2640014196202	62161	D5701	.RUNFLAT,INSERT USE WITH RADIAL	4
					TIRE ONLY.....	
17	PAOZZ	2640013349453	19207	12342638	.RUNFLAT,INSERT USE WITH RADIAL OR	4
					BIAS TIRE,USE WITH RIM P/N 12342642,(3400 LB),PART OF KIT P/N 57K0237...	
					UOC:AVY,A11,A13,A14,A15,A20,A24,A25,A26,A27,B16,B17,B18,HVY,H11,H13,H14,H15,H16,H17,H18,H20,H21,H24,H25,H26,H27,H28,MMM	
18	PAOZZ	2530013382730	34623	12342639	.BEADLOCK,TIRE RIM USE WITH RADIAL	1
					TIRE ONLY AND RIM P/N 12342642,(3400 LB).....	
					UOC:AVY,A11,A13,A14,A15,A20,A24,A25,A26,A27,B16,B17,B18,HVY,H11,H13,H14,H15,H16,H17,H18,H20,H21,H24,H25,H26,H27,H28,MMM	
18	PAOZZ	2530013865499	19207	12342911	.BEADLOCK,TIRE RIM USE WITH BIAS	1
					TIRE ONLY,PART OF KIT P/N 57K0237...	
					UOC:AVY,A11,A13,A14,A15,A20,A24,A25,	

SECTION II			TM9-2320-280-24P			
(1)	(2)	(3)	(4)	(5)	(6)	(7)
ITEM NO	SMR CODE	NSN	CAGEC	PART NUMBER	DESCRIPTION AND USABLE ON CODES(UC)	QTY
19	PAOZZ	2530014178450	34623	12460178	A26,A27,B16,B17,B18,HVY,H11,H13,H14,H15,H16,H17,H18,H20,H21,H24,H25,H26,H27,H28,MMM .RIM,WHEEL,PNEUMATIC USE WITH RIM P/N 12460177,(3850 LB),PART OF KIT P/N 57K3527.....	1
19	PAOZZ	2530013363127	19207	12342640	.RIM,WHEEL,PNEUMATIC USE WITH RIM P/N 12342642,(3400 LB)..... UOC:AVY,A11,A13,A14,A15,A20,A24,A25,A26,A27,B16,B17,B18,HVY,H11,H13,H14,H15,H16,H17,H18,H20,H21,H24,H25,H26,H27,H28,MMM	1
20	PAOZZ	5310011987585	19207	12339501	.NUT,SELF-LOCKING,HE 1/2-20,USE WITH 3850 AND 3400 LB WHEEL,PART OF KIT P/N 57K3527.....	12
21	PAOZZ	2640010982029	81348	TYIV/CL1/TRVC8	.CAP,PNEUMATIC VALVE USE WITH RADIAL TIRE ONLY,PART OF KIT P/N 57K3527.....	1
22	PAOZZ	2640000501229	81348	TYV/CL2/TR C1	.VALVE CORE USE WITH RADIAL TIRE ONLY PART OF KIT P/N 57K0297,PART OF KIT P/N 57K3527.....	1
23	PAOZZ	2640013354583	19207	12342634	.VALVE,PNEUMATIC TIR USE WITH RADIAL TIRE ONLY PART OF KIT P/N 57K0297,PART OF KIT P/N 57K3527.....	1
24	PAOZZ	4730013461063	19207	12342793	.ADAPTER,STRAIGHT,PI USE WITH RADIAL TIRE ONLY PART OF KIT P/N 57K0297,PART OF KIT P/N 57K3527.....	1
25	PAOZZ	5331013463806	19207	12342794	.O-RING USE WITH RADIAL TIRE ONLY PART OF KIT P/N 57K0297,PART OF KIT P/N 57K3527.....	1
26	PAOZZ	5310004492376	96906	MS21245-8	.NUT,SELF-LOCKING,HE 1/2-20,USE WITH RADIAL TIRE ONLY PART OF KIT P/N 57K0297,PART OF KIT P/N 57K3527.	1
27	PAOZZ	2640014196200	62161	D528235-H1	LUBRICANT,RUNFLAT 11 OZ TUBE.....	4

END OF FIGURE

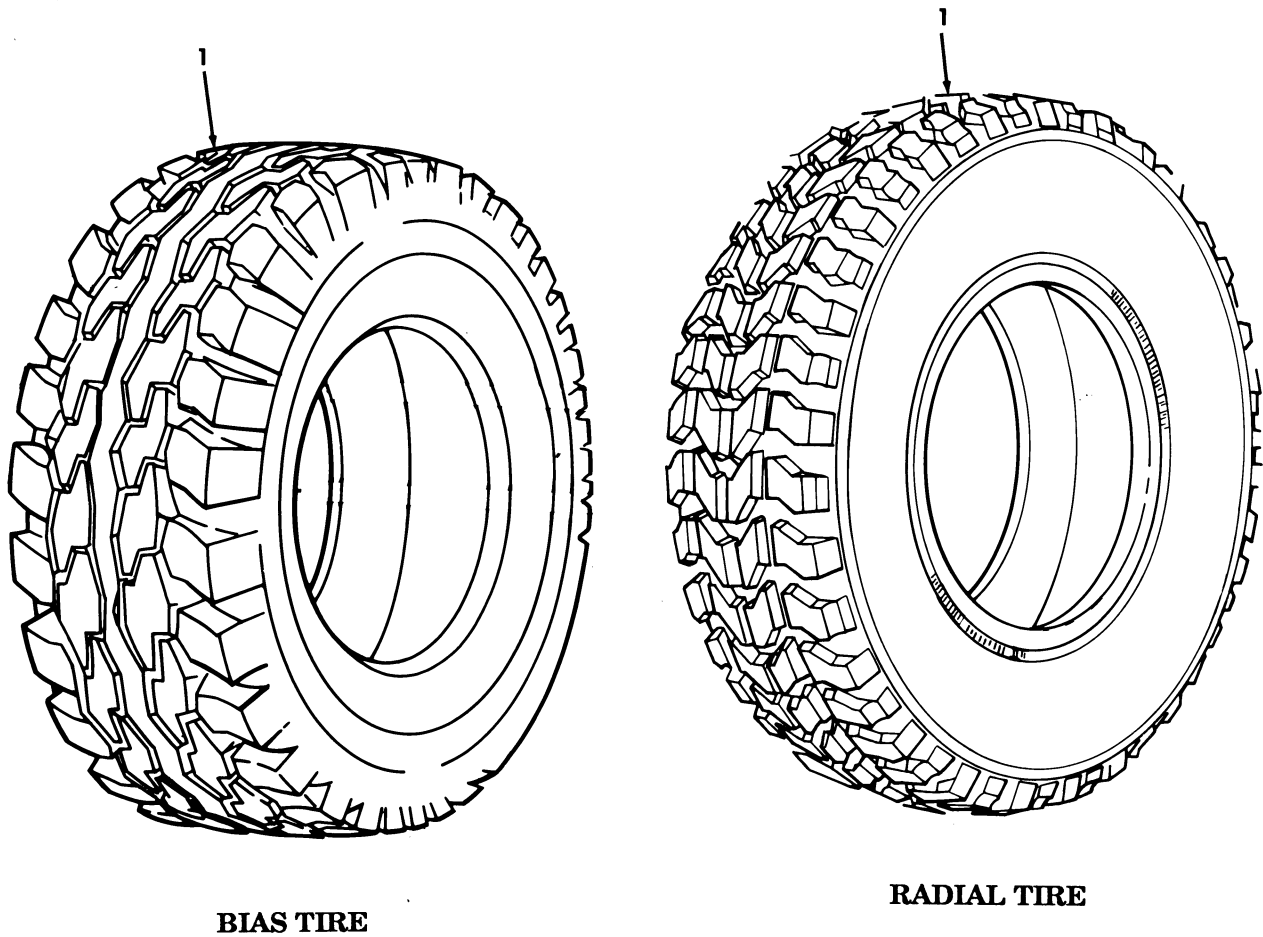

*Figure 168. Tires.*

SECTION II			TM9-2320-280-24P			
(1)	(2)	(3)	(4)	(5)	(6)	(7)
ITEM	SMR			PART		
NO	CODE	NSN	CAGEC	NUMBER	DESCRIPTION AND USABLE ON CODES(UC)	QTY
					GROUP 1313 TIRES,TUBES,TIRE CHAINS	
					FIG. 168 TIRES	
1	PCOFH	2610011714746	81348	ZZ-T-381/36-1250 -16.5/C/G2A/LTTR	TIRE,PNEUMATIC BIAS,36 X 12.50 X 16.50..... UC:H11,H13,H14,H15,H16,H17,H18,H20, H21,H24,H25,H26,H27,H28,MMM	4
1	PCOFH	2610013337632	81348	GP3STYLXTYRACLO/ O/37-12.50R16.50	TIRE,PNEUMATIC RADIAL,37 X 12.50 X 16.50.....	4

END OF FIGURE

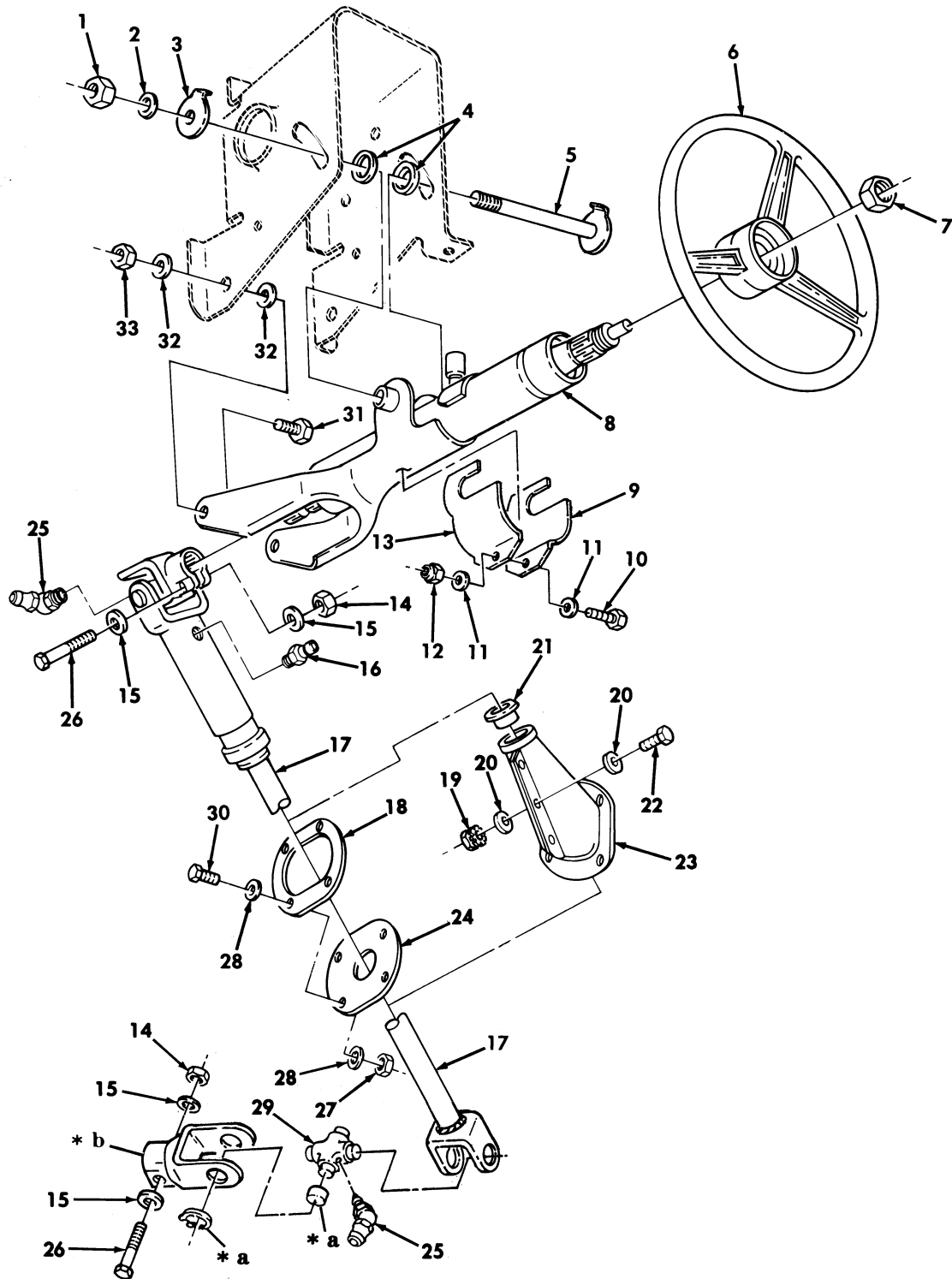

- \* a PART OF ITEM 29
- \* b PART OF ITEM 17

Figure 169. Steering Column, Wheel, and Intermediate Shaft.

SECTION II			TM9-2320-280-24P			
(1)	(2)	(3)	(4)	(5)	(6)	(7)
ITEM NO	SMR CODE	NSN	CAGEC	PART NUMBER	DESCRIPTION AND USABLE ON CODES(UOC)	QTY
GROUP 14 STEERING						
1401 MECHANICAL STEERING GEAR ASSEMBLY						
FIG. 169 STEERING COLUMN,WHEEL,AND INTERMEDIATE SHAFT						
1	PAOZZ	5310009359021	96906	MS51943-35	NUT,SELF-LOCKING,HE 3/8-16 PART OF KIT P/N 57K3205.....	1
2	PAOZZ	5310006379541	96906	MS35338-46	WASHER,LOCK 3/8.....	1
3	PAOZZ	5310011880745	34623	5585103	WASHER,KEY PART OF KIT P/N 57K3205..	1
4	PAOZZ	5310011881093	19207	12339308	WASHER,RECESSED USE WITH STEERING GEAR P/N 1419.....	2
5	PAOZZ	5315012013592	19207	12339310	PIN,STRAIGHT,THREAD PART OF KIT P/N 57K3205.....	1
6	PAOZZ	2530014112729	19207	12446803	STEERING WHEEL.....	1
7	PAOZZ	5310001263842	19207	7063812	NUT,PLAIN,HEXAGON 5/8-18.....	1
8	PAOZZ	2530014112735	34623	12446802	HOUSING,STEERING CO PART OF KIT P/N 57K3205.....	1
9	PAOZZ	2530013835740	34623	12342875	SUPPORT,STEERING CO USBL EFF 100, 000 AND ABOVE..... UOC:AVY,A11,A13,A14,A15,A20,A24,A25, A26,A27,BVY,B15,B16,B17,B18,B20,B24, B25,C17,HVY,NNN	1
10	PAOZZ	5305002253843	80204	B1821BH025C100N	SCREW,CAP,HEXAGON H 1/4-20 X 1.00, USBL EFF 100,000 AND ABOVE..... UOC:AVY,A11,A13,A14,A15,A20,A24,A25, A26,A27,BVY,B15,B16,B17,B18,B20,B24, B25,C17,HVY,NNN	1
11	PAOZZ	5310008094058	96906	MS27183-10	WASHER,FLAT USBL EFF 100,000 AND ABOVE..... UOC:AVY,A11,A13,A14,A15,A20,A24,A25, A26,A27,BVY,B15,B16,B17,B18,B20,B24, B25,C17,HVY,NNN	2
12	PAOZZ	5310000881251	81349	M45913/1-4CG5C	NUT,SELF-LOCKING,HE USBL EFF 100, 000 AND ABOVE..... UOC:AVY,A11,A13,A14,A15,A20,A24,A25, A26,A27,BVY,B15,B16,B17,B18,B20,B24, B25,C17,HVY,NNN	1
13	PAOZZ	2530013847154	19207	12342876	SUPPORT,STEERING CO USBL EFF 100, 000 AND ABOVE..... UOC:AVY,A11,A13,A14,A15,A20,A24,A25, A26,A27,BVY,B15,B16,B17,B18,B20,B24, B25,C17,HVY,NNN	1
14	PAOZZ	5310008406222	19207	8712289-4	NUT,SELF-LOCKING,HE 7/16-20.....	2
15	PAOZZ	5310008094085	96906	MS27183-16	WASHER,FLAT 7/16.....	4
16	PAOZZ	4730001720010	96906	MS15002-1	FITTING,LUBRICATION.....	1
17	PAOOO	2520012142565	78500	902-04-48-244	PROPELLER SHAFT WIT.....	1
18	PAOZZ	5365011932951	34623	5582851	SPACER,PLATE USBL EFF 1 THRU 46161. UOC:H11,H13,H14,H15,H16,H17,H18,H20, H21,H24,H25,H26,H27,H28,MMM	1
19	PAOZZ	5310009349764	96906	MS35649-205	NUT,PLAIN,HEXAGON #10-24, USBL EFF 46162 AND ABOVE.....	3

SECTION II			TM9-2320-280-24P			
(1)	(2)	(3)	(4)	(5)	(6)	(7)
ITEM	SMR			PART		
NO	CODE	NSN	CAGEC	NUMBER	DESCRIPTION AND USABLE ON CODES(UC)	QTY
20	PAOZZ	5310000145850	96906	MS27183-42	WASHER,FLAT #10, USBL EFF 46162 AND ABOVE.....	6
21	PAOZZ	2530007537285	96881	14L14-F	NYLINER USBL EFF 46162 AND ABOVE...	1
22	PAOZZ	5305002400194	96906	MS51849-76	SCREW,MACHINE #10-24 X 3/4, USBL EFF 46162 AND ABOVE.....	3
23	PCOZZ	2530012858381	34623	SF-5597695	BOOT,VEHICULAR COMP USBL EFF 46162 AND ABOVE.....	1
24	PAOZZ	5330012097723	34623	5584384	SEAL,PLAIN USBL EFF 1 THRU 46161... UOC:H11,H13,H14,H15,H16,H17,H18,H20,H21,H24,H25,H26,H27,H28,MMM	1
25	PAOZZ	4730005852653	36251	5311	FITTING,LUBRICATION.....	2
26	PAOZZ	5306011922207	7X677	454977	BOLT,MACHINE 7/16-20 X 2.00.....	2
27	PAOZZ	5310000614650	96906	MS51943-31	NUT,SELF-LOCKING,HE 1/4-20 PART OF KIT P/N 57K3205.....	6
28	PAOZZ	5310011023270	24617	2436161	WASHER,FLAT 1/4.....	8
29	PAOZZ	2520003522168	78500	CPL6N8	SPIDER,UNIVERSAL JO..... UOC:HVY,H11,H13,H14,H15,H16,H17,H18,H20,H21,H24,H25,H26,H27,H28,MMM	2
30	PAOZZ	5305002253843	80204	B1821BH025C100N	SCREW,CAP,HEXAGON H 1/4-20 X 1.00 PART OF KIT P/N 57K3205.....	4
31	PAOZZ		34623	12342440	BOLT,SHOULDER 1/4-20 X 7/8,USE WITH STEERING GEAR P/N 1493..... UOC:AVY,A11,A13,A14,A15,A20,A24,A25,A26,A27,B16,B17,B18,HVY,H11,H13,H14,H15,H16,H17,H18,H20,H21,H24,H25,H26,H27,H28,MMM	2
31	PAOZZ	5305014491983	19207	12447027	SCREW,CAP,SOCKET HE 5/16-18X.750, USE WITH STEERING GEAR P/N 12446802 PART OF KIT P/N 57K3205.....	2
32	PAOZZ	5310012577719	34623	5593235	WASHER,FLAT 5/16..... UOC:AVY,A11,A13,A14,A15,A20,A24,A25,A26,A27,B16,B17,B18,HVY,H11,H13,H14,H15,H16,H17,H18,H20,H21,H24,H25,H26,H27,H28,MMM	2
32	PAOZZ	5310011191024	24617	2436162	WASHER,FLAT 5/16,USE WITH STEERING GEAR P/N 12446802 PART OF KIT P/N 57K3205..... UOC:BVY,B15,B20,B24,B25,C17,NNN	4
33	PAOZZ	5310000614650	96906	MS51943-31	NUT,SELF-LOCKING,HE 1/4-20..... UOC:AVY,A11,A13,A14,A15,A20,A24,A25,A26,A27,B16,B17,B18,HVY,H11,H13,H14,H15,H16,H17,H18,H20,H21,H24,H25,H26,H27,H28,MMM	1
33	PAOZZ	5310008140673	96906	MS51943-33	NUT,SELF-LOCKING,HE 5/16-18,USE WITH STEERING GEAR P/N 12446802 PART OF KIT P/N 57K3205..... UOC:BVY,B15,B20,B24,B25,C17,NNN	2

END OF FIGURE

Section II.

TM 9-2320-280-24P-1

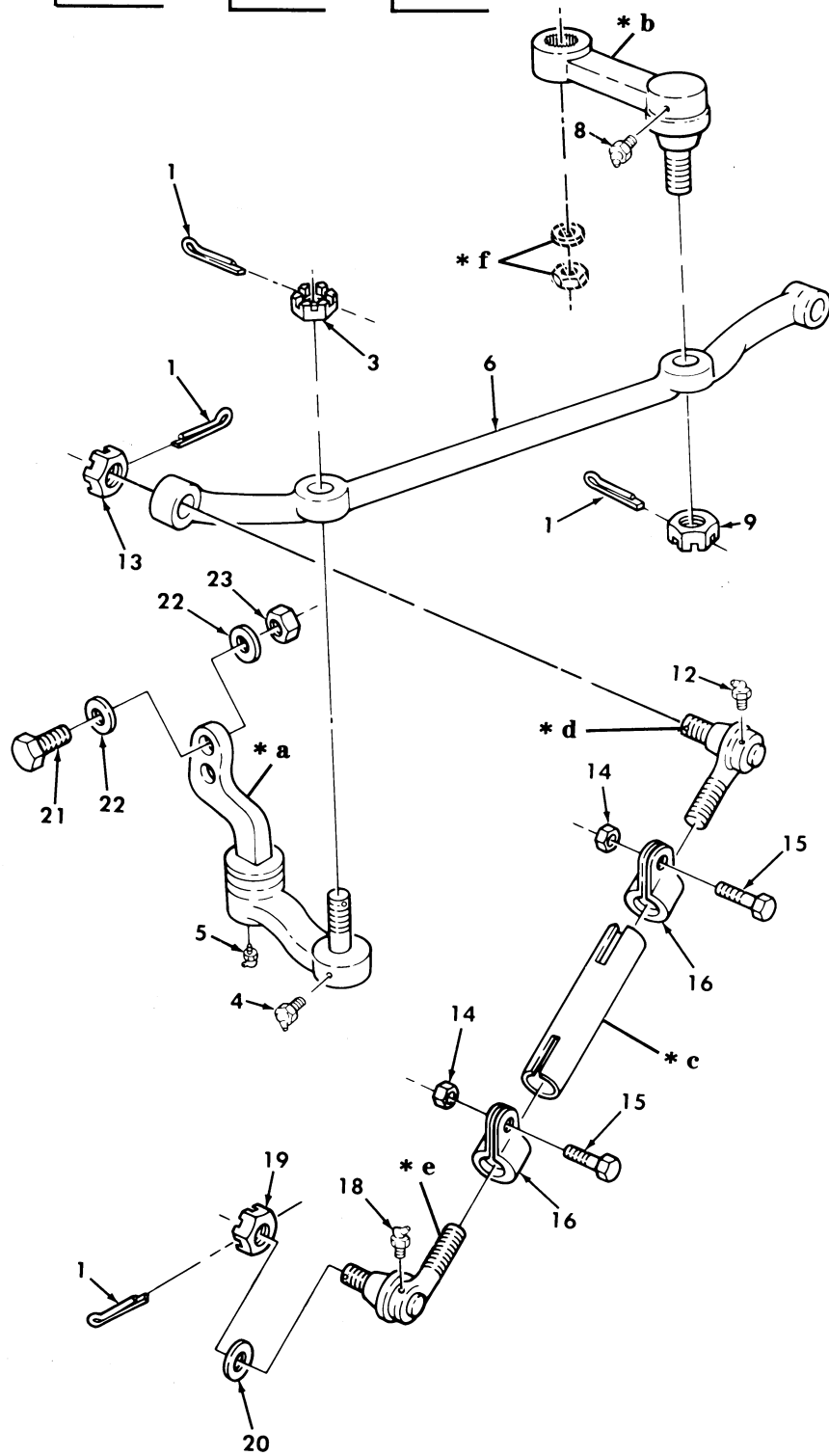
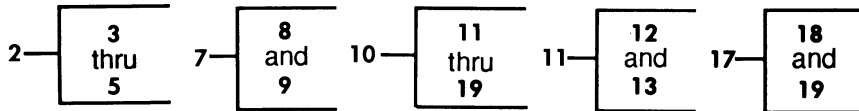

- \* a PART OF ITEM 2
- \* b PART OF ITEM 7
- \* c PART OF ITEM 10
- \* d PART OF ITEM 11
- \* e PART OF ITEM 17
- \* f SEE FIGURE 172, ITEMS 17,18

Figure 170. Steering Linkage.



SECTION II			TM9-2320-280-24P			
(1)	(2)	(3)	(4)	(5)	(6)	(7)
ITEM	SMR			PART		
NO	CODE	NSN	CAGEC	NUMBER	DESCRIPTION AND USABLE ON CODES(UOC)	QTY
GROUP 1401 MECHANICAL STEERING GEAR ASSEMBLY						
FIG. 170 STEERING LINKAGE						
1	PAOZZ	5315000120123	24617	137195	PIN,COTTER 1.8 X 1-1/4.....	6
2	PAOZZ	2530012491577	98349	L-20-MA-133-A-11	IDLER ARM,STEERING,.....	1
					UOC:AVY,A11,A13,A14,A15,A20,A24,A25,A26,A27,B16,B17,B18,HVY,H11,H13,H14,H15,H16,H17,H18,H20,H21,H24,H25,H26,H27,H28,MMM	
2	PAOZZ	2530014203839	34623	6004839	IDLER ARM,STEERING,.....	1
					UOC:BVY,B15,B20,B24,B25,C17,NNN	
3	PAOZZ	5310008507004	96906	MS35692-54	.NUT,PLAIN,SLOTTED,H 5/8-18.....	1
4	PAOZZ	4730000504203	24617	9417901	.FITTING,LUBRICATION.....	1
5	PAOZZ	4730000504205	7X677	9411030	.FITTING,LUBRICATION.....	1
6	PAOZZ	2530011859651	19207	12338622	DRAG LINK,STEERING.....	1
					UOC:AVY,A11,A13,A14,A15,A20,A24,A25,A26,A27,B16,B17,B18,HVY,H11,H13,H14,H15,H16,H17,H18,H20,H21,H24,H25,H26,H27,H28,MMM	
6	PAOZZ	2530014203837	34623	6003868	DRAG LINK,STEERING.....	1
					UOC:BVY,B15,B20,B24,B25,C17,NNN	
7	PAOZZ	2530012528362	98349	L-20-MA-132-A-11	ARM,STEERING GEAR.....	1
					UOC:AVY,A11,A13,A14,A15,A20,A24,A25,A26,A27,B16,B17,B18,HVY,H11,H13,H14,H15,H16,H17,H18,H20,H21,H24,H25,H26,H27,H28,MMM	
7	PAOZZ	2530014205180	34623	6004838	ARM,STEERING GEAR.....	1
					UOC:BVY,B15,B20,B24,B25,C17,NNN	
8	PAOZZ	4730000504203	96906	MS15001-1	.FITTING,LUBRICATION.....	1
9	PAOZZ	5310008507004	96906	MS35692-54	.NUT,PLAIN,SLOTTED,H 5/8-18.....	1
10	PAOZZ	2530011942049	98349	L-18-VT-5276-B-1	TIE ROD,STEERING L.H. AND R.H.....	2
				1	UOC:AVY,A11,A13,A14,A15,A20,A24,A25,A26,A27,B16,B17,B18,HVY,H11,H13,H14,H15,H16,H17,H18,H20,H21,H24,H25,H26,H27,H28,MMM	
10	PAOZZ	2530014212563	34623	06005119	TIE ROD,STEERING.....	2
					UOC:BVY,B15,B20,B24,B25,C17,NNN	
11	PAOZZ	2530011892195	98349	L-18-SV-5151-C-1	.TIE ROD END,STEERIN R.H.....	1
				2		
12	PAOZZ	4730000504205	96906	MS15001-3	..FITTING,LUBRICATION R.H.....	1
13	PAOZZ	5310008507004	96906	MS35692-54	..NUT,PLAIN,SLOTTED,H 5/8-18.....	1
14	PAOZZ	5310002416659	96906	MS51943-37	.NUT,SELF-LOCKING,HE 7/16-14.....	2
15	PAOZZ	5305012117478	7X677	9419079	.SCREW,CAP,HEXAGON H 7/16-14 X 1.75	2
16	PAOZZ	5340011918161	98349	L-18-CPS-5-A-10	.CLAMP,LOOP L.H.....	2
17	PAOZZ	2530011972160	98349	L-18-SV-5150-C-1	.TIE ROD END,STEERIN L.H.....	1
				2		
18	PAOZZ	4730000504205	96906	MS15001-3	..FITTING,LUBRICATION L.H.....	1
19	PAOZZ	5310008507004	96906	MS35692-54	..NUT,PLAIN,SLOTTED,H 5/8-18.....	1
20	PAOZZ	5310011517347	24617	2436167	WASHER,FLAT 5/8.....	2
21	PAOZZ	5305007813930	80204	B1821BH038C475N	SCREW,CAP,HEXAGON H 7/16-14 X 4.75.	2
22	PAOZZ	5310008094061	96906	MS27183-15	WASHER,FLAT 7/16.....	4

SECTION II			TM9-2320-280-24P			
(1)	(2)	(3)	(4)	(5)	(6)	(7)
ITEM	SMR			PART		
NO	CODE	NSN	CAGEC	NUMBER	DESCRIPTION AND USABLE ON CODES (UOC)	QTY
23	PAOZZ	5310008960903	96906	MS51967-12	NUT,PLAIN,HEXAGON 7/16-14.....	2

END OF FIGURE

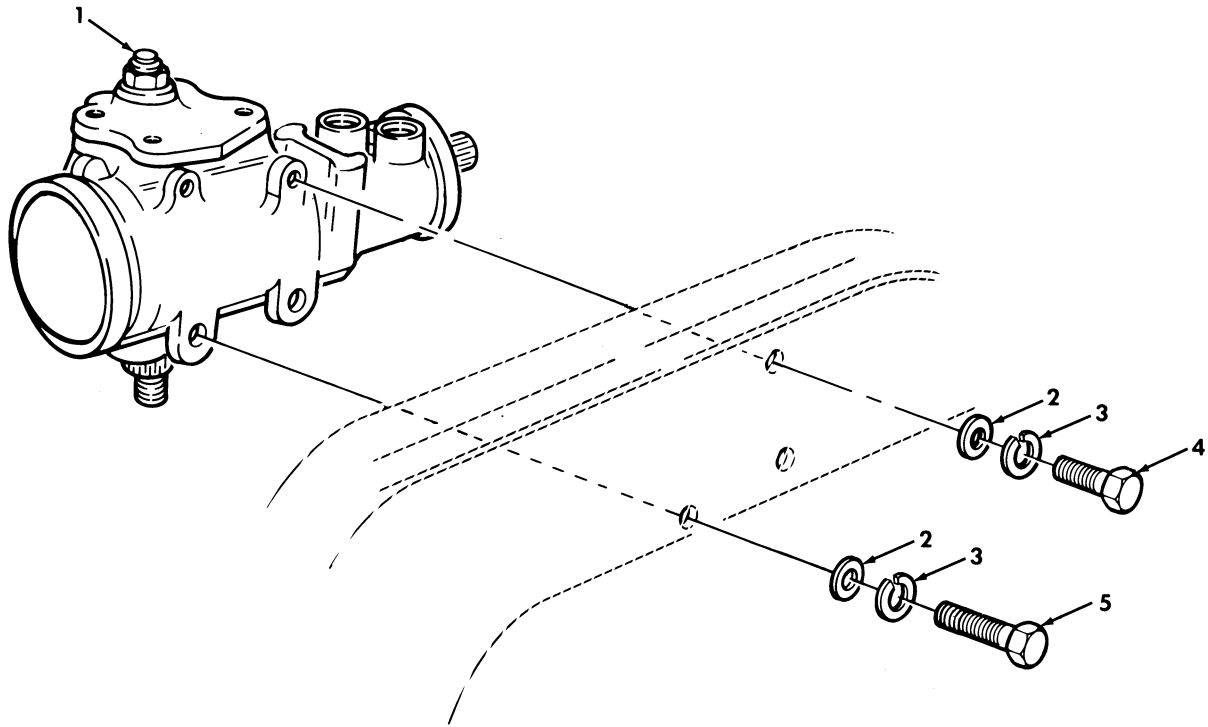
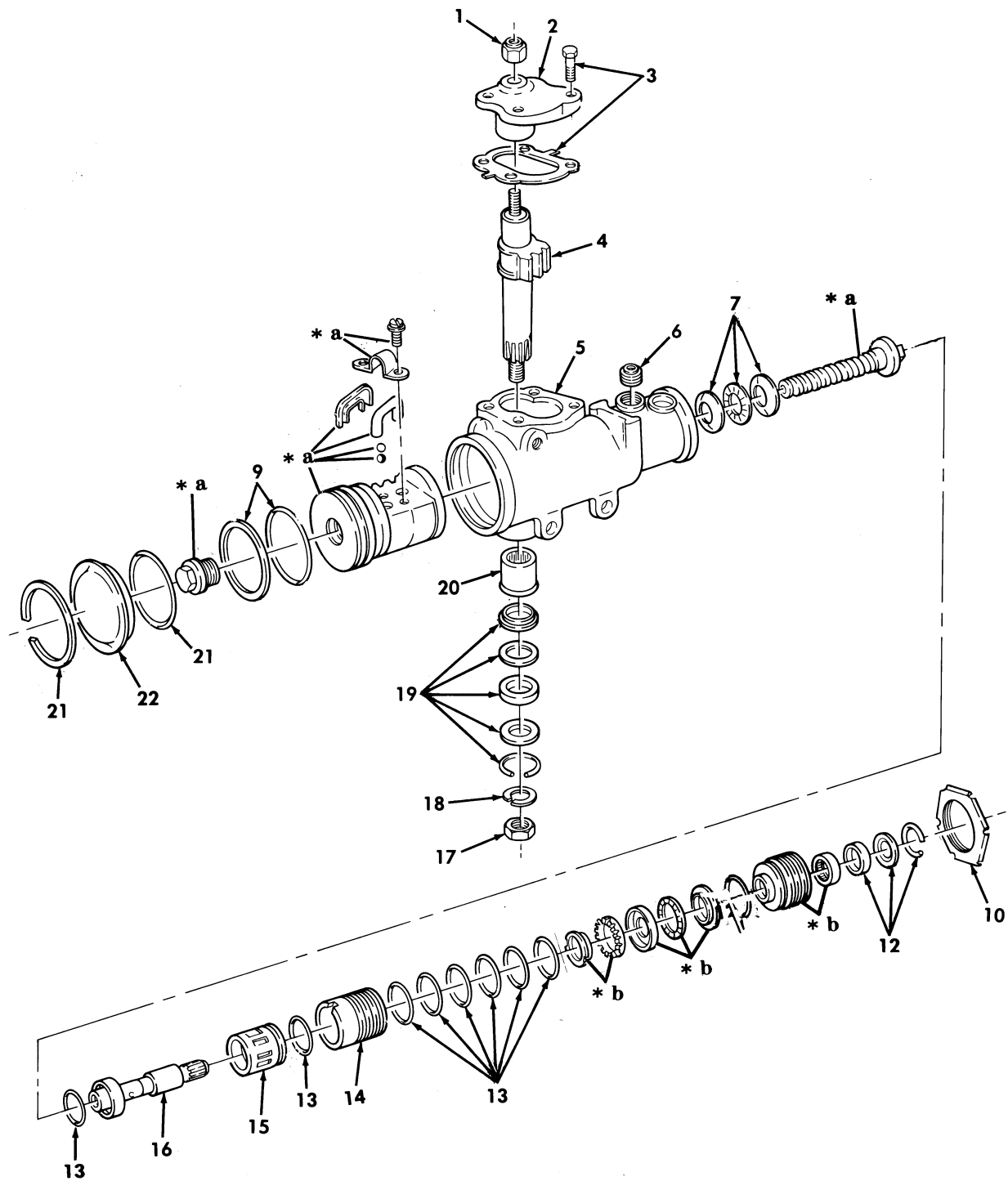

Figure 171. Power Steering Gear and Mounting Hardware.

SECTION II			TM9-2320-280-24P			
(1)	(2)	(3)	(4)	(5)	(6)	(7)
ITEM	SMR			PART		
NO	CODE	NSN	CAGEC	NUMBER	DESCRIPTION AND USABLE ON CODES(UC)	QTY
					GROUP 1407 POWER STEERING GEAR ASSEMBLY	
					FIG. 171 POWER STEERING GEAR AND MOUNTING HARDWARE	
1	PAOFF	2530014231796	34623	12460232	STEERING GEAR.....	1
2	PAOZZ	5310008094085	96906	MS27183-16	WASHER,FLAT 7/16.....	3
3	PAOZZ	5310002090965	96906	MS35338-47	WASHER,LOCK 7/16.....	3
4	PAOZZ	5306012546356	96906	MS35764-861	BOLT,SELF-LOCKING 7/16-14 X 4.00...	1
5	PAOZZ	5305012134149	7X677	9430761	SCREW,CAP,HEXAGON H 7/16-14 X 5.25.	2

END OF FIGURE

8— 9    11— 12



\* a PART OF ITEM 8  
 \* b PART OF ITEM 11

Figure 172. Power Steering Gear Assembly.

SECTION II			TM9-2320-280-24P			
(1)	(2)	(3)	(4)	(5)	(6)	(7)
ITEM NO	SMR CODE	NSN	CAGEC	PART NUMBER	DESCRIPTION AND USABLE ON CODES(UOC)	QTY
GROUP 1407 POWER STEERING GEAR ASSEMBLY						
FIG. 172 POWER STEERING GEAR ASSEMBLY						
1	PAFZZ	5310010388500	34623	5740444	NUT, SELF-LOCKING, SI.....	1
2	XAFZZ		34623	5740446	COVER, ASSEMBLY.....	1
3	PAFZZ	2530010977659	34623	5740448	SEAL KIT PART OF KIT P/N 57K0239	1
					PART OF KIT P/N 57K3489.....	
4	XDFZZ		34623	5740442	GEARSHAFT, SPUR.....	1
5	XAFZZ		34623	5740454	HOUSING, STEERING.....	1
					UOC:AVY, A11, A13, A14, A15, A20, A24, A25, A26, A27, B16, B17, B18, HVY, H11, H13, H14, H15, H16, H17, H18, H20, H21, H24, H25, H26, H27, H28, MMM	
5	XAFZZ		52788	26049931	HOUSING, STEERING.....	1
					UOC:BVY, B15, B20, B24, B25, C17, NNN	
6	PAFZZ	4820011914262	7X677	7834284	PARTS KIT, SAFETY RE PART OF KIT P/N 57K0242.....	1
7	PAFZZ	3110010406541	34623	5740476	BEARING ASSEMBLY PART OF KIT P/N 57K0242.....	1
8	PAFHH	3040011234942	34623	5740462	PARTS KIT, LINEAR AC PART OF KIT P/N 57K0242.....	1
9	PAFZZ	2530010331855	34623	5740465	.PARTS KIT, STEERING PART OF KIT P/N 57K0240.....	1
10	PAFZZ	5310010388501	34623	5741145	NUT, ADJUST PLUG LOC.....	1
11	PAFZZ	2530010334237	52788	7817725	PARTS KIT, STEERING PART OF KIT P/N 57K0242.....	1
12	PFFZZ	5330008439235	34623	5741892	.PARTS KIT, SEAL REPL PART OF KIT P/N 57K0241.....	1
13	PAFZZ	2530009609363	34623	5740499	PARTS KIT, STEERING PART OF KIT P/N 57K0241.....	1
14	KFFZZ		34623	5740495	BODY, VALVE PART OF KIT P/N 7846626..	1
15	KFFZZ		34623	5740497	VALVE, LINEAR, DIRECT PART OF KIT P/N 7846626.....	1
16	KFFZZ		34623	5740498	SHAFT, STEERING COLU PART OF KIT P/N 7846626.....	1
17	PAOZZ	5310001668567	7X677	5667628	NUT, PLAIN, HEXAGON.....	1
18	PAOZZ	5310011442779	34623	5550554	WASHER, LOCK 7/8.....	1
19	PAFZZ	5330010969650	34623	5740452	SEAL, PITMAN SHAFT PART OF KIT P/N 57K0239 USE WITH P/N 12339896.....	1
					UOC:AVY, A11, A13, A14, A15, A20, A24, A25, A26, A27, B16, B17, B18, HVY, H11, H13, H14, H15, H16, H17, H18, H20, H21, H24, H25, H26, H27, H28, MMM	
19	PAFZZ	5330013248260	7X677	26002516	SEAL, PLAIN ENCASED PART OF KIT P/N 57K3489 USE WITH P/N 12460232.....	1
20	PAFZZ	3110004031488	34623	5740453	BEARING, ROLLER, NEED.....	1
21	PAFZZ	2530010341715	34623	5740458	PARTS KIT, STEERING PART OF KIT P/N 57K0240.....	1
22	PAFZZ	5340009609340	34623	5740456	CAP-PLUG, PROTECTIVE.....	1

END OF FIGURE

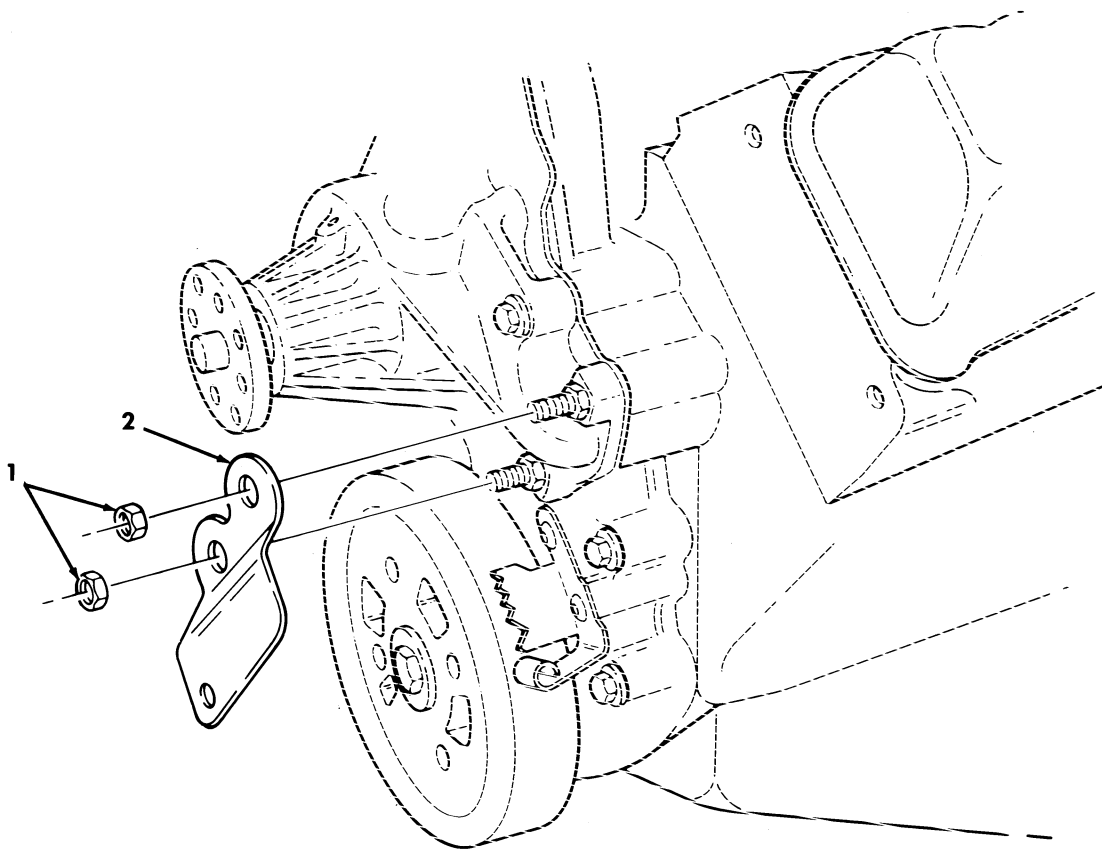

*Figure 173. Power Steering Pump Support Bracket.*

SECTION II			TM9-2320-280-24P			
(1)	(2)	(3)	(4)	(5)	(6)	(7)
ITEM	SMR			PART		
NO	CODE	NSN	CAGEC	NUMBER	DESCRIPTION AND USABLE ON CODES(UC)	QTY
					GROUP 1410 HYDRAULIC PUMP OR FLUID MOTOR ASSEMBLY	
					FIG. 173 POWER STEERING PUMP SUPPORT BRACKET	
1	PAOZZ	5310011272456	K1076	9145-105-00B	NUT,PLAIN,HEXAGON 10-1.5 MM.....	2
					UOC:AVY,A11,A13,A14,A15,A20,A24,A25,A26,A27,B16,B17,B18,HVY,H11,H13,H14,H15,H16,H17,H18,H20,H21,H24,H25,H26,H27,H28,MMM	
2	PAOZZ	2590012073696	19207	12338774	BRACKET,VEHICULAR C FRONT.....	1
					UOC:AVY,A11,A13,A14,A15,A20,A24,A25,A26,A27,B16,B17,B18,HVY,H11,H13,H14,H15,H16,H17,H18,H20,H21,H24,H25,H26,H27,H28,MMM	

END OF FIGURE



**USE WITH BASIC AND A1 VEHICLES**

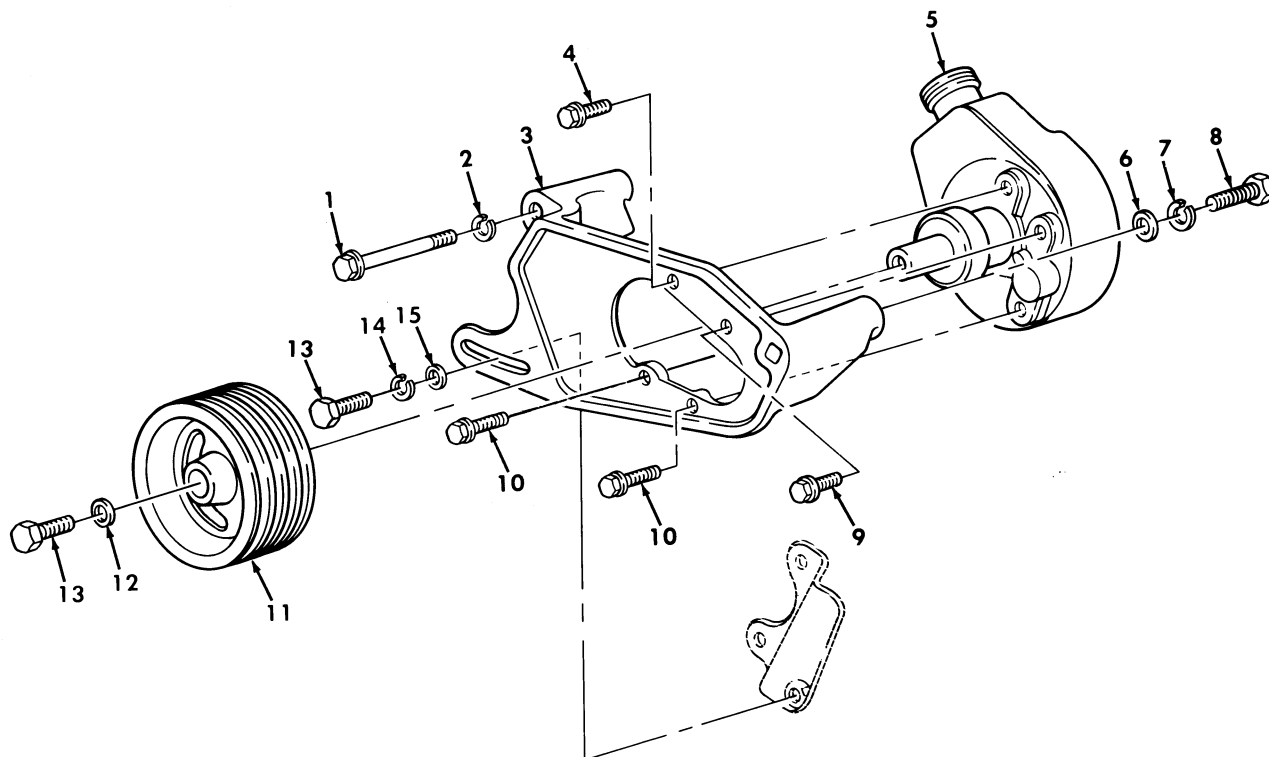

*Figure 174. Power Steering Pump, Pulley, and Mounting Hardware.*

SECTION II			TM9-2320-280-24P			
(1)	(2)	(3)	(4)	(5)	(6)	(7)
ITEM NO	SMR CODE	NSN	CAGEC	PART NUMBER	DESCRIPTION AND USABLE ON CODES(UOC)	QTY
					GROUP 1410 HYDRAULIC PUMP OR FLUID MOTOR ASSEMBLY	
					FIG. 174 POWER STEERING PUMP,PULLEY, AND MOUNTING HARDWARE	
1	PAOZZ	5306012643531	34623	5597252	BOLT,MACHINE 10-1.5 X 100MM..... UOC:AVY,A11,A13,A14,A15,A20,A24,A25,A26,A27,B16,B17,B18,HVY,H11,H13,H14,H15,H16,H17,H18,H20,H21,H24,H25,H26,H27,H28,MMM	1
2	PAOZZ	5310012067306	7X677	11500207	WASHER,LOCK 10MM..... UOC:AVY,A11,A13,A14,A15,A20,A24,A25,A26,A27,B16,B17,B18,HVY,H11,H13,H14,H15,H16,H17,H18,H20,H21,H24,H25,H26,H27,H28,MMM	1
3	PAOZZ	5342012035661	19207	12338775	BRACKET,ENGINE ACCE..... UOC:AVY,A11,A13,A14,A15,A20,A24,A25,A26,A27,B16,B17,B18,HVY,H11,H13,H14,H15,H16,H17,H18,H20,H21,H24,H25,H26,H27,H28,MMM	1
4	PAOZZ	5306012519190	34623	G-11501940	BOLT,MACHINE 10-1.5 X 20 MM..... UOC:AVY,A11,A13,A14,A15,A20,A24,A25,A26,A27,B16,B17,B18,HVY,H11,H13,H14,H15,H16,H17,H18,H20,H21,H24,H25,H26,H27,H28,MMM	1
5	PAOFF	2530011687876	19207	12339495	PUMP ASSEMBLY,POWER..... UOC:AVY,A11,A13,A14,A15,A20,A24,A25,A26,A27,B16,B17,B18,HVY,H11,H13,H14,H15,H16,H17,H18,H20,H21,H24,H25,H26,H27,H28,MMM	1
6	PAOZZ	5310011211703	06032	2310-0143-001	WASHER,FLAT 1/2..... UOC:AVY,A11,A13,A14,A15,A20,A24,A25,A26,A27,B16,B17,B18,HVY,H11,H13,H14,H15,H16,H17,H18,H20,H21,H24,H25,H26,H27,H28,MMM	1
7	PAOZZ	5310005845272	02978	ERNA245	WASHER,LOCK 1/2..... UOC:AVY,A11,A13,A14,A15,A20,A24,A25,A26,A27,B16,B17,B18,HVY,H11,H13,H14,H15,H16,H17,H18,H20,H21,H24,H25,H26,H27,H28,MMM	1
8	PAOZZ	5305000712069	80204	B1821BH050C150N	SCREW,CAP,HEXAGON H 1/2-13 X 1.50.. UOC:AVY,A11,A13,A14,A15,A20,A24,A25,A26,A27,B16,B17,B18,HVY,H11,H13,H14,H15,H16,H17,H18,H20,H21,H24,H25,H26,H27,H28,MMM	1
9	PAOZZ	5305012542521	7X677	11500827	SCREW,CAP,HEXAGON H 10-1.5 X 16 MM. UOC:AVY,A11,A13,A14,A15,A20,A24,A25,A26,A27,B16,B17,B18,HVY,H11,H13,H14,H15,H16,H17,H18,H20,H21,H24,H25,H26,H27,H28,MMM	1
10	PAOZZ	5306012542357	34623	G-11500829	BOLT,MACHINE 10-1.5 X 25 MM..... UOC:AVY,A11,A13,A14,A15,A20,A24,A25,	2

SECTION II			TM9-2320-280-24P			
(1)	(2)	(3)	(4)	(5)	(6)	(7)
ITEM	SMR			PART		
NO	CODE	NSN	CAGEC	NUMBER	DESCRIPTION AND USABLE ON CODES(UOC)	QTY
11	PAOZZ	3020012101391	19207	12338773	A26,A27,B16,B17,B18,HVY,H11,H13,H14, H15,H16,H17,H18,H20,H21,H24,H25,H26, H27,H28,MMM PULLEY,GROOVE.....	1
					UOC:AVY,A11,A13,A14,A15,A20,A24,A25, A26,A27,B16,B17,B18,HVY,H11,H13,H14, H15,H16,H17,H18,H20,H21,H24,H25,H26, H27,H28,MMM	
12	PAOZZ	5310012581536	OMAY0	5593221	WASHER,FLAT 3/8.....	1
					UOC:AVY,A11,A13,A14,A15,A20,A24,A25, A26,A27,B16,B17,B18,HVY,H11,H13,H14, H15,H16,H17,H18,H20,H21,H24,H25,H26, H27,H28,MMM	
13	PAOZZ	5305000680510	80204	B1821BH038C100N	SCREW,CAP,HEXAGON H 3/8-16 X 1.00..	2
					UOC:AVY,A11,A13,A14,A15,A20,A24,A25, A26,A27,B16,B17,B18,HVY,H11,H13,H14, H15,H16,H17,H18,H20,H21,H24,H25,H26, H27,H28,MMM	
14	PAOZZ	5310006379541	96906	MS35338-46	WASHER,LOCK 3/8.....	1
					UOC:AVY,A11,A13,A14,A15,A20,A24,A25, A26,A27,B16,B17,B18,HVY,H11,H13,H14, H15,H16,H17,H18,H20,H21,H24,H25,H26, H27,H28,MMM	
15	PAOZZ	5310000806004	96906	MS27183-14	WASHER,FLAT 3/8.....	1
					UOC:AVY,A11,A13,A14,A15,A20,A24,A25, A26,A27,B16,B17,B18,HVY,H11,H13,H14, H15,H16,H17,H18,H20,H21,H24,H25,H26, H27,H28,MMM	

END OF FIGURE

**USE WITH A2 VEHICLES**

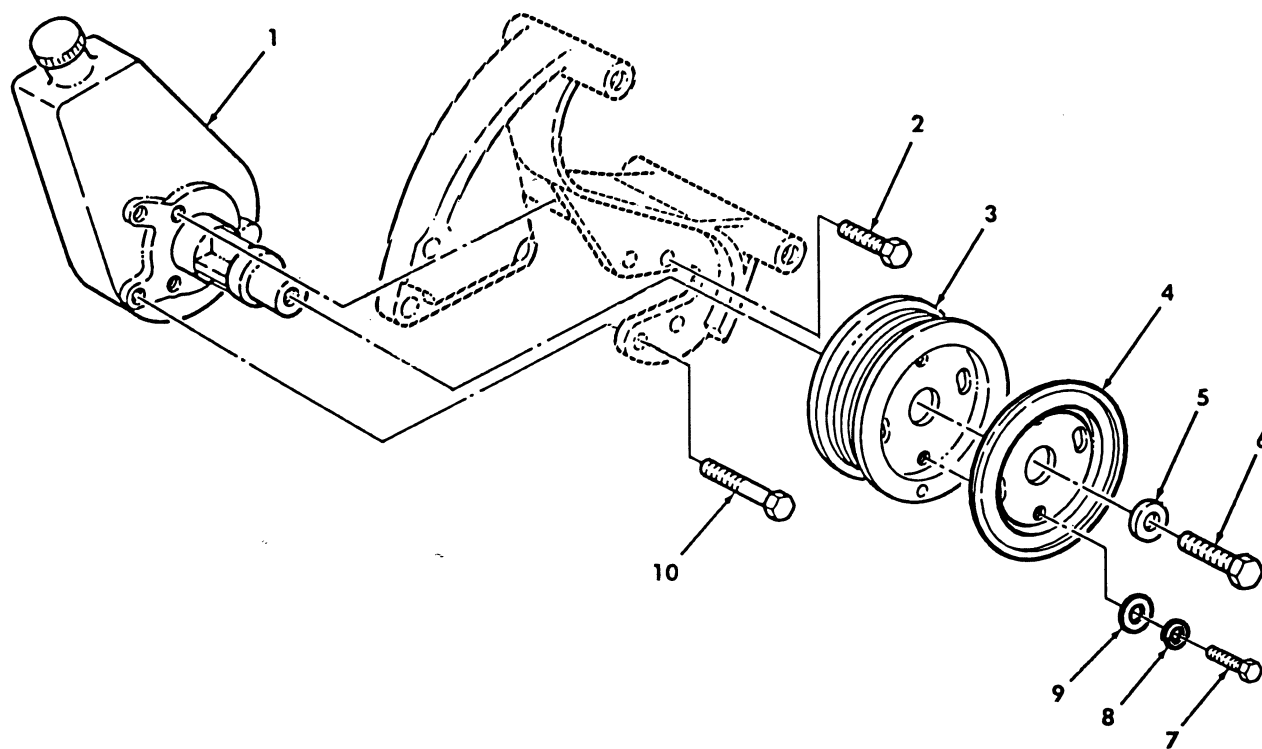
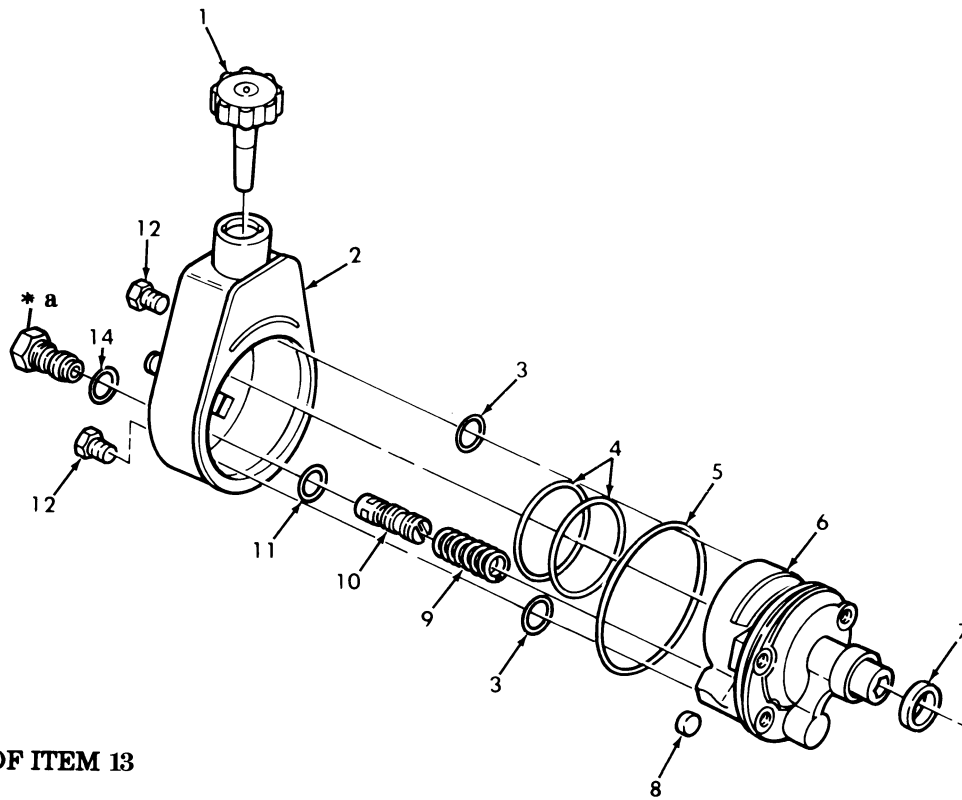

*Figure 175. Power Steering Pump, Pulley, and Mounting Hardware.*

SECTION II			TM9-2320-280-24P			
(1)	(2)	(3)	(4)	(5)	(6)	(7)
ITEM	SMR			PART		
NO	CODE	NSN	CAGEC	NUMBER	DESCRIPTION AND USABLE ON CODES(UC)	QTY
					GROUP 1410 HYDRAULIC PUMP OR FLUID MOTOR ASSEMBLY	
					FIG. 175 POWER STEERING PUMP,PULLEY, AND MOUNTING HARDWARE	
1	PAOFF	2530014602439	34623	RCSK18330	PUMP ASSEMBLY,POWER.....	1
					UOC:BVY,B15,B20,B24,B25,C17,NNN	
2	PAOZZ	5306012434650	7X677	11504596	BOLT,MACHINE.....	2
					UOC:BVY,B15,B20,B24,B25,C17,NNN	
3	PAOZZ	3020014442311	34623	RCSK18686	PULLEY,GROOVE.....	1
					UOC:BVY,B15,B20,B24,B25,C17,NNN	
4	PAOZZ	3020014766520	19207	12469106	FLANGE,PULLEY.....	1
					UOC:BVY,B15,B20,B24,B25,C17,NNN	
5	PAOZZ	5310012113811	7X677	9417793	WASHER,FLAT 3/8.....	1
					UOC:BVY,B15,B20,B24,B25,C17,NNN	
6	PAOZZ	5305000680510	80204	B1821BH038C100N	SCREW,CAP,HEXAGON H.....	1
					UOC:BVY,B15,B20,B24,B25,C17,NNN	
7	PAOZZ	5305011409118	80204	B1821BH038C088N	SCREW,CAP,HEXAGON H.....	2
					UOC:BVY,B15,B20,B24,B25,C17,NNN	
8	PAOZZ	5310006379541	96906	MS35338-46	WASHER,LOCK.....	2
					UOC:BVY,B15,B20,B24,B25,C17,NNN	
9	PAOZZ	5310000806004	96906	MS27183-14	WASHER,FLAT.....	2
					UOC:BVY,B15,B20,B24,B25,C17,NNN	
10	PAOZZ	5306011857048	7X677	11513606	BOLT,MACHINE.....	2
					UOC:BVY,B15,B20,B24,B25,C17,NNN	

END OF FIGURE

13-14



\* a PART OF ITEM 13

Figure 176. Power Steering Pump Assembly.

SECTION II			TM9-2320-280-24P			
(1)	(2)	(3)	(4)	(5)	(6)	(7)
ITEM NO	SMR CODE	NSN	CAGEC	PART NUMBER	DESCRIPTION AND USABLE ON CODES(UC)	QTY
					GROUP 1410 HYDRAULIC PUMP OR FLUID MOTOR ASSEMBLY	
					FIG. 176 POWER STEERING PUMP ASSEMBLY	
1	PAOZZ	6680011522845	7X677	7834183	GAGE ROD-CAP, LIQUID.....	1
2	XAFZZ		34623	5740430	RESERVOIR ASSEMBLY.....	1
3	KFFZZ		34623	5740429	SEAL PART OF KIT P/N 7848522.....	2
4	KFFZZ		34623	5740464	RING, SEAL PART OF KIT P/N 7848522...	2
5	KFFZZ		34623	5740431	SEAL PART OF KIT P/N 7848522.....	1
6	PAFZZ	4320011555145	34623	5740432	HOUSING, LIQUID PUMP.....	1
7	KFFZZ		34623	5741746	SEAL PART OF KIT P/N 7848522.....	1
8	KFFZZ		52788	5692682	MAGNET, PERMANENT PART OF KIT P/N 7848522.....	1
9	PAOZZ	5360011496308	7X677	5688037	SPRING, HELICAL, COMP.....	1
10	PAOZZ	4820010837993	34623	5740433	CARTRIDGE, RELIEF VA.....	1
11	PAOZZ	5330008484439	48018	5688049	GASKET PART OF KIT P/N 7848522.....	1
12	PAOZZ	5305011629713	7X677	7830239	SCREW, CAP, HEXAGON H.....	2
13	PAOZZ	4320011555153	7X677	7830913	CONNECTOR, FLUID, PUM.....	1
14	PAOZZ	5331011571884	34623	5740436	.O-RING PART OF KIT P/N 7848522.....	1

END OF FIGURE

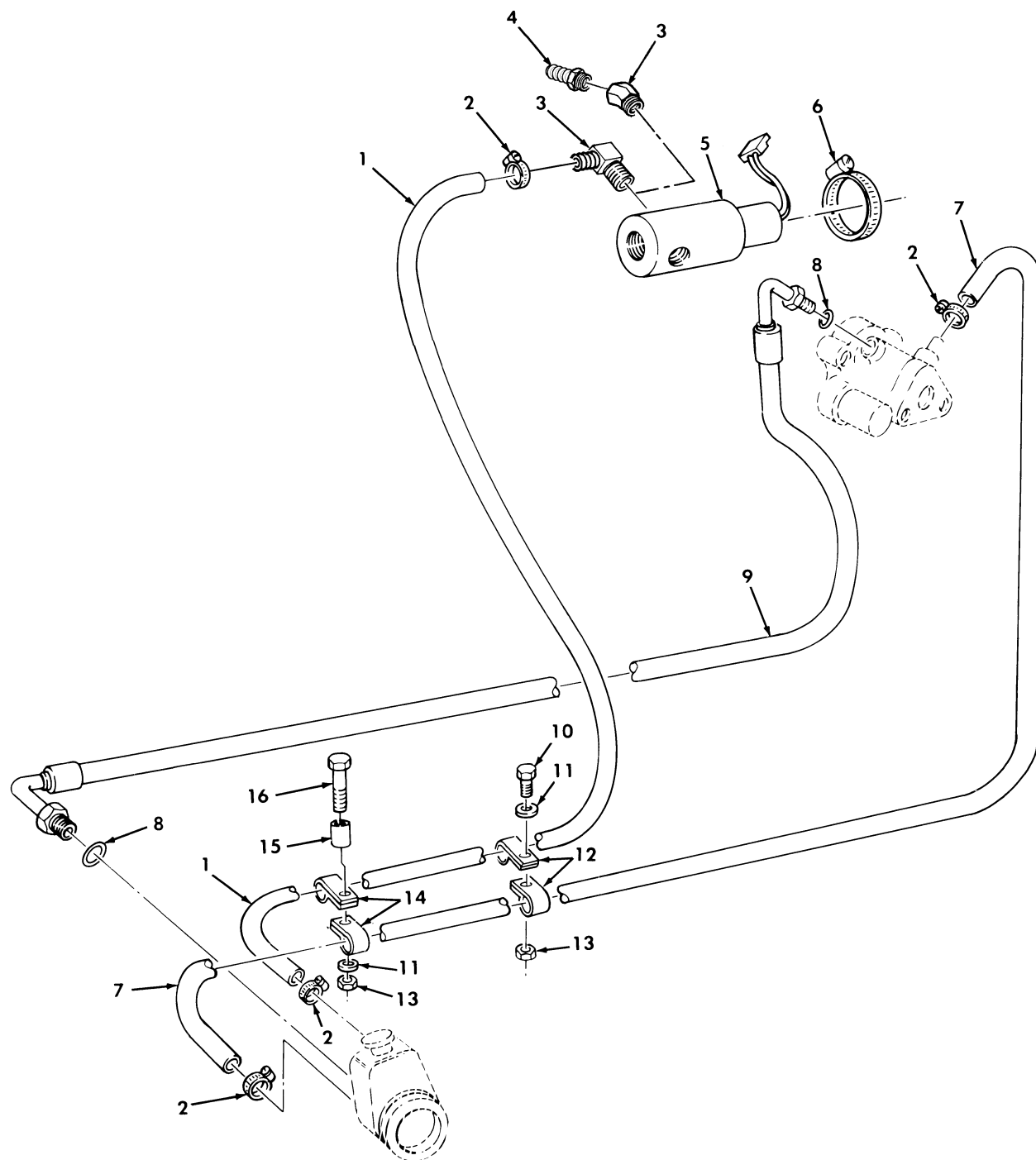

Figure 177. Power Steering and Hydro-Booster Hydraulic Lines and Fittings.



SECTION II			TM9-2320-280-24P			
(1)	(2)	(3)	(4)	(5)	(6)	(7)
ITEM	SMR			PART		
NO	CODE	NSN	CAGEC	NUMBER	DESCRIPTION AND USABLE ON CODES(UC)	QTY
GROUP 1411 HOSES,LINES,FITTINGS						
FIG. 177 POWER STEERING AND HYDRO-BOOSTER HYDRAULIC LINES AND FITTINGS						
1	MOZZ		34623	5590023	HOSE MAKE FROM HOSE,P/N 6490610019, 23 INCHES LONG.....	1
2	PAZZ	4730011188278	76599	MMF4-SS	CLAMP,HOSE.....	4
3	PAZZ	4730007890951	79470	110-03604	ELBOW,PIPE TO TUBE.....	1
					UC:AVY,A11,A13,A14,A20,A24,A25,A26, A27,B16,B17,B18,HVY,H11,H13,H14,H16, H17,H18,H20,H21,H24,H25,H26,H27,H28, MMM	
3	PAZZ	4730009115707	21450	454097	ELBOW,PIPE TO TUBE.....	1
					UC:A15,BVY,B15,B20,B24,B25,C17,H15, NNN	
4	PAZZ		19207	12460305	ADAPTER,STRAIGHT,P.....	1
					UC:A15,BVY,B15,B20,B24,B25,C17,H15, NNN	
5	PAZZ	4810011925817	51376	1059-06607-01	VALVE,SOLENOID.....	1
6	PAZZ	4730002043491	66295	C32P	CLAMP,HOSE.....	1
7	MOZZ		34623	5590024	HOSE,NONMETALLIC MAKE FROM HOSE,P/N 6490610019,41 INCHES LONG.....	1
8	PAZZ	5331005806586	02697	2-011N674-70	O-RING.....	2
9	PAZZ	4720012123531	19207	12338957	HOSE ASSEMBLY,NONME.....	1
10	PAZZ	5305000687837	80204	B1821BH025C063N	SCREW,CAP,HEXAGON H 1/4-20 X 5/8...	1
11	PAZZ	5310008094058	96906	MS27183-10	WASHER,FLAT 1/4.....	2
12	PAZZ	5340007255280	96906	MS21333-125	CLAMP,LOOP.....	2
13	PAZZ	5310000614650	96906	MS51943-31	NUT,SELF-LOCKING,HE 1/4-20.....	2
14	PAZZ	5340011539425	75272	COV-1109Z1	CLAMP,LOOP.....	2
15	PAZZ	5365012115094	19207	12340486	SPACER,SLEEVE.....	1
16	PAZZ	5306012542359	34623	5593024	BOLT,MACHINE 1/4-20 X 2.50.....	1

END OF FIGURE

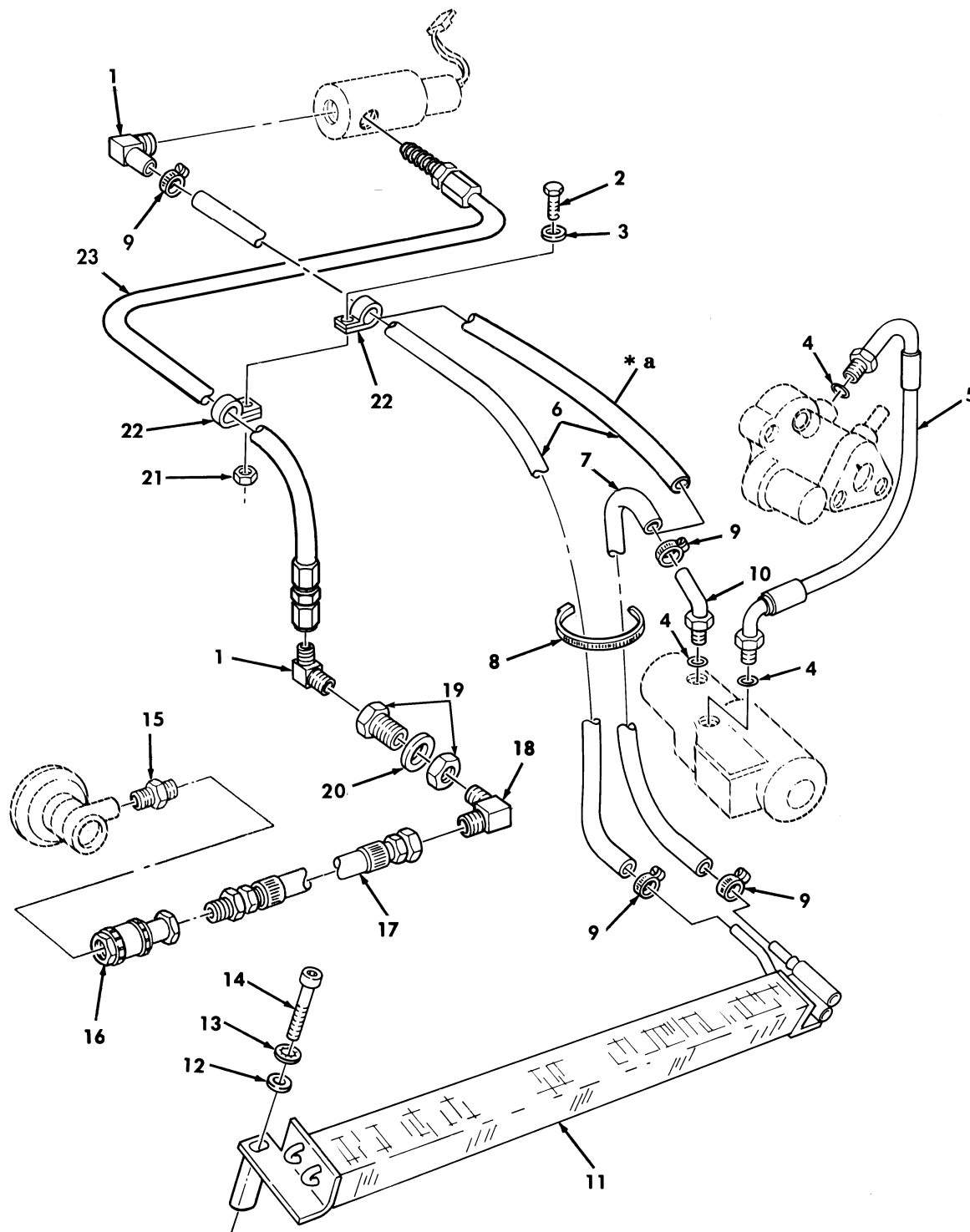

Figure 178. Power Steering Oil Cooler, Hydro-Booster, and Fan Clutch Hydraulic Lines and Fittings.

SECTION II			TM9-2320-280-24P			
(1)	(2)	(3)	(4)	(5)	(6)	(7)
ITEM NO	SMR CODE	NSN	CAGEC	PART NUMBER	DESCRIPTION AND USABLE ON CODES(UOC)	QTY
GROUP 1411 HOSES,LINES,FITTINGS						
FIG. 178 POWER STEERING OIL COOLER, HYDRO-BOOSTER,AND FAN CLUTCH HYDRAULIC LINES AND FITTINGS						
1	PAOZZ	4730007890951	79470	110-03604	ELBOW,PIPE TO HOSE.....	2
2	PAOZZ	5305000687837	80204	B1821BH025C063N	SCREW,CAP,HEXAGON H 1/4-20 X 5/8...	1
3	PAOZZ	5310008094058	96906	MS27183-10	WASHER,FLAT 1/4.....	1
4	PAOZZ	5331005806586	02697	2-011N674-70	O-RING.....	3
5	PAOZZ	4720012131574	16717	FB9778-01	HOSE ASSEMBLY,NONME.....	1
6	MOOZZ		34623	5590025	HOSE,NONMETALLIC MAKE FROM HOSE,P/N 6490610019,27 INCHES LONG, USBL EFF 1 THRU 99,999.....	1
6	MOOZZ		19207	12338330-7	HOSE,NONMETALLIC MAKE FROM HOSE,P/N 6490610019,45 INCHES LONG, USBL EFF 100,000 AND ABOVE.....	1
7	MOOZZ		19207	12338330-6	HOSE,NONMETALLIC MAKE FROM HOSE,P/N 6490610019,29 INCHES LONG, USBL EFF 100,000 AND ABOVE.....	1
8	PAOZZ	5975009856630	96906	MS3367-3-0	STRAP,TIEDOWN,ELECT USBL EFF 100, 000 AND ABOVE.....	1
9	PAOZZ	4730008776298	18876	8486066	CLAMP,HOSE.....	4
10	PAOZZ	4710012094628	34623	12338593	TUBE ASSEMBLY,METAL.....	1
11	PAOZZ	2520013162630	34623	12342142	COOLER,FLUID,TRANSM 100,000 AND ABOVE.....	1
12	PAOZZ	5310000814219	96906	MS27183-12	WASHER,FLAT 5/16,USBL EFF 100,000 AND ABOVE.....	2
13	PAOZZ	5310001670721	24617	138538	WASHER,LOCK 5/16, USBL EFF 100,000 AND ABOVE.....	2
14	PAOZZ	5305009926143	80205	MS16995-72	SCREW,CAP,SOCKET HE 5/16-18 X 2 1/ 2, USBL EFF 100,000 AND ABOVE.....	2
15	PAOZZ	4730009003296	72983	248X4	ADAPTER,STRAIGHT,PI.....	1
16	PAOZZ	4730013990241	19207	12342947	COUPLING HALF,QUICK USE WITH HOSE 12338591-1.....	1
17	PAOZZ	4720011890853	19207	12338591	HOSE ASSEMBLY,NONME.....	1
17	PAOZZ	4720013943747	19207	12338591-1	HOSE ASSEMBLY,NONME USE WITH COUPLING 12342947.....	1
18	PAOZZ	4730003663011	79470	49X4X4	ELBOW,PIPE TO TUBE.....	1
19	PAOZZ	4730008975497	79470	W21204	COUPLING,PIPE 3/4.....	1
20	PAOZZ	5310011264751	43689	123-4497645	PIEC WASHER,FLAT.....	1
				E 8		
21	PAOZZ	5310000614650	96906	MS51943-31	NUT,SELF-LOCKING,HE 1/4-20.....	1
22	PAOZZ	5340007255280	96906	MS21333-125	CLAMP,LOOP.....	2
23	PAOZZ	4720014703076	19207	12469061	HOSE ASSEMBLY,NONME.....	1

END OF FIGURE

1  
2  
thru  
18

*USE WITH BASIC AND A1 VEHICLES*

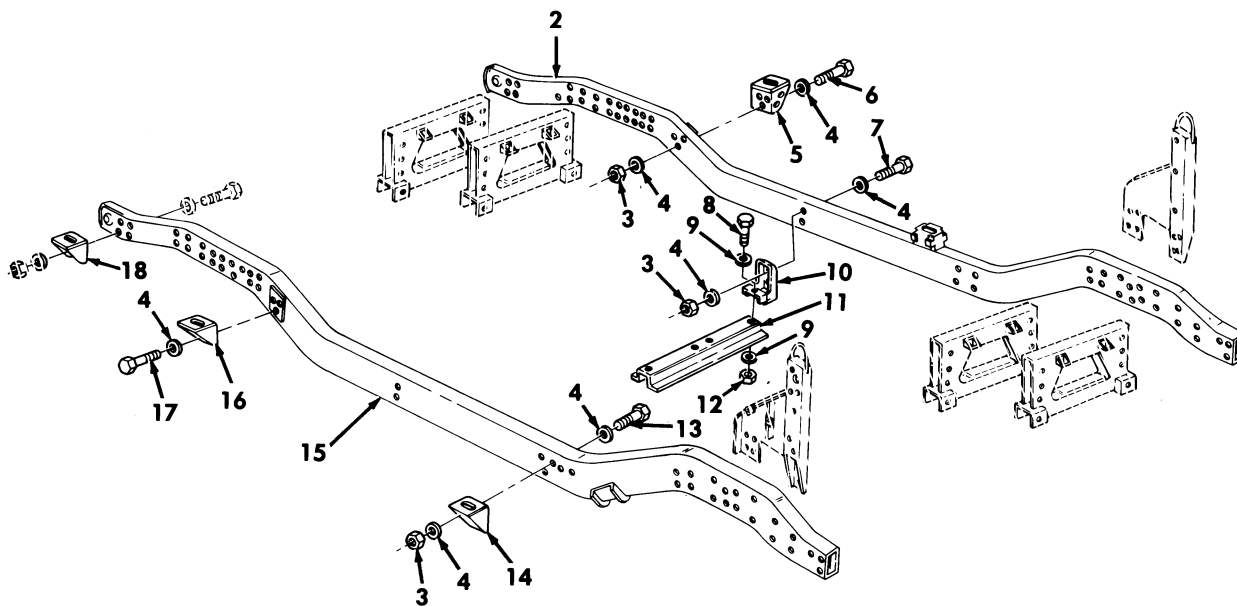
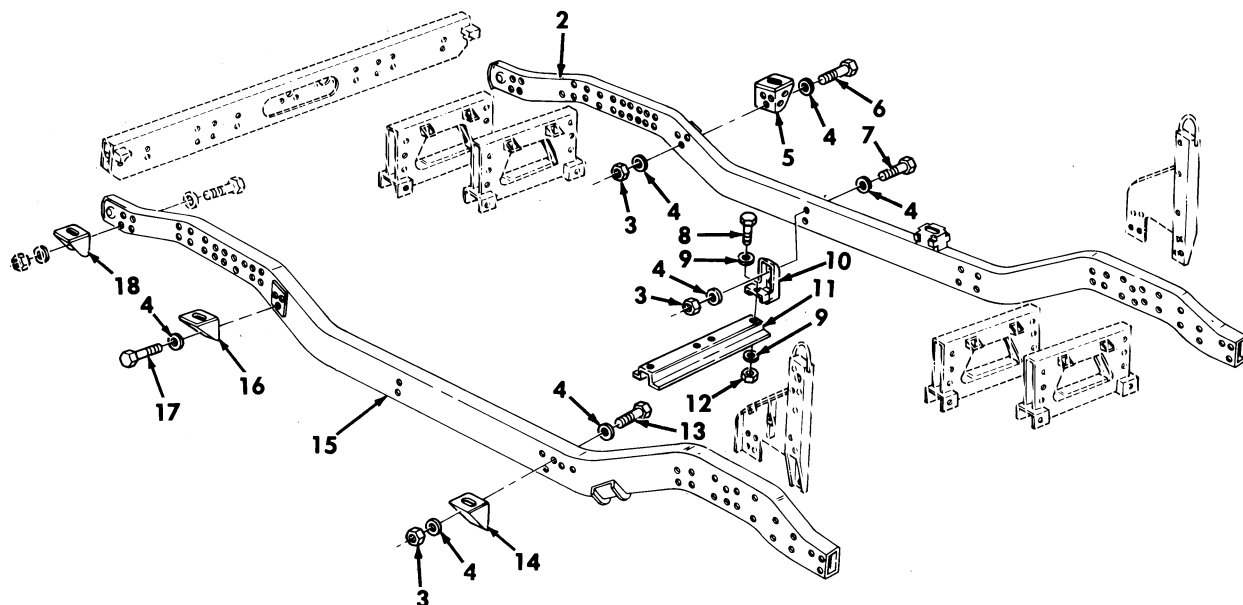

*Figure 179. Frame Assembly, Body Mount Brackets, and Transmission Crossmember.*

SECTION II			TM9-2320-280-24P			
(1)	(2)	(3)	(4)	(5)	(6)	(7)
ITEM	SMR			PART		
NO	CODE	NSN	CAGEC	NUMBER	DESCRIPTION AND USABLE ON CODES(UOC)	QTY
					GROUP 15 FRAME,TOWING ATTACHMENTS, DRAWBARS AND ARTICULATION SYSTEM 1501 FRAME ASSEMBLY	
					FIG. 179 FRAME ASSEMBLY,BODY MOUNT BRACKETS,AND TRANSMISSION CROSSMEMBER	
1	XDHHH		19207	12338234-1	FRAME ASSEMBLY.....	1
					UOC:H28	
1	XDHHH		19207	12338233-1	FRAME ASSEMBLY USBL EFF 1 THRU 99, 999.....	1
					UOC:H14,H18,H27	
1	XDHHH		19207	12338233-2	FRAME ASSEMBLY.....	1
					UOC:H11,H13,H17,H20,H24,H25,MMM	
1	XDHHH		19207	12338233-3	FRAME ASSEMBLY USBL EFF 1 THRU 99, 999.....	1
					UOC:H26	
1	XDHHH		19207	12338233-4	FRAME ASEMBLY.....	1
					UOC:H25	
1	XDHHH		19207	12338233-5	FRAME ASSEMBLY USBL EFF 100,000 AND ABOVE.....	1
					UOC:H14,H18,H26,H27	
1	XDHHH		19207	12338233-6	FRAME ASSEMBLY COMPLETE, USBL EFF 100,000 AND ABOVE.....	1
					UOC:H26	
1	XBHHH		19207	12338234	FRAME ASSEMBLY.....	1
					UOC:H15,H16,H21	
1	XDHHH		19207	12342972-1	FRAME ASSEMBLY COMP.....	1
					UOC:A11,A13,A20,A24,A25,B17	
1	XDHHH		19207	12342972-2	FRAME ASSEMBLY.....	1
					UOC:A14,A26,A27,B18	
1	XDHHH		19207	12446978-1	FRAME ASSEMBLY.....	1
					UOC:BVY,B15	
1	XBHHH		19207	12342503	FRAME ASSEMBLY.....	1
					UOC:AVY,A15,B16,HVY	
1	XDHHH		19207	12342972-1	FRAME ASSEMBLY COMP.....	1
					UOC:A11,A13,A20,A24,A25,B17	
2	PBZZZ	2510012491599	19207	12338246	.RAIL ASSEMBLY,FRAM L.H.....	1
					UOC:AVY,A11,A13,A14,A15,A20,A24,A25, A26,A27,B16,B17,B18,HVY,H11,H13,H14, H15,H16,H17,H18,H20,H21,H24,H25,H26, H27,H28,MMM	
3	PAFZZ	5310004883889	96906	MS51943-39	.NUT,SELF-LOCKING,HE 1/2-13.....	12
					UOC:AVY,A11,A13,A14,A15,A20,A24,A25, A26,A27,B16,B17,B18,HVY,H11,H13,H14, H15,H16,H17,H18,H20,H21,H24,H25,H26, H27,H28,MMM	
4	PAFZZ	5310012538948	34623	5593320	.WASHER,FLAT 1/2.....	27
					UOC:AVY,A11,A13,A14,A15,A20,A24,A25, A26,A27,B16,B17,B18,HVY,H11,H13,H14, H15,H16,H17,H18,H20,H21,H24,H25,H26, H27,H28,MMM	

SECTION II			TM9-2320-280-24P			
(1)	(2)	(3)	(4)	(5)	(6)	(7)
ITEM	SMR			PART		
NO	CODE	NSN	CAGEC	NUMBER	DESCRIPTION AND USABLE ON CODES(UOC)	QTY
5	PFHZZ	5340012491576	19207	12338187-1	.BRACKET,ANGLE L.H..... UOC:HVY,H11,H13,H14,H15,H16,H17,H18, H20,H21,H24,H25,H26,H27,H28,MMM	1
6	PAFZZ	5305000712082	80204	B1821BH050C475N	.SCREW,CAP,HEXAGON H 1/2-13 X 4.75. UOC:AVY,A11,A13,A14,A15,A20,A24,A25, A26,A27,B16,B17,B18,HVY,H11,H13,H14, H15,H16,H17,H18,H20,H21,H24,H25,H26, H27,H28,MMM	3
7	PAFZZ	5305011857122	34623	5591781	.SCREW,CAP,HEXAGON H 1/2-13 X 4.25. UOC:AVY,A11,A13,A14,A15,A20,A24,A25, A26,A27,B16,B17,B18,HVY,H11,H13,H14, H15,H16,H17,H18,H20,H21,H24,H25,H26, H27,H28,MMM	4
8	PAFZZ	5306012534426	96906	MS35764-887	.BOLT,SELF-LOCKING 9/16-12 X 1.50.. UOC:AVY,A11,A13,A14,A15,A20,A24,A25, A26,A27,B16,B17,B18,HVY,H11,H13,H14, H15,H16,H17,H18,H20,H21,H24,H25,H26, H27,H28,MMM	2
9	PAFZZ	5310000685285	96906	MS27183-20	.WASHER,FLAT 9/16..... UOC:AVY,A11,A13,A14,A15,A20,A24,A25, A26,A27,B16,B17,B18,H15,H16,H17,H18, H20,H21,H24,H25,H26,H27,H28,MMM,NNN	4
10	PFFZZ	2590011860863	19207	12338185	.BRACKET,VEHICULAR C..... UOC:AVY,A11,A13,A14,A15,A20,A24,A25, A26,A27,B16,B17,B18,HVY,H11,H13,H14, H15,H16,H17,H18,H20,H21,H24,H25,H26, H27,H28,MMM	2
11	PAFZZ	2510011757221	19207	12338147	.FRAME SECTION,STRUC..... UOC:AVY,A11,A13,A14,A15,A20,A24,A25, A26,A27,B16,B17,B18,HVY,H11,H13,H14, H15,H16,H17,H18,H20,H21,H24,H25,H26, H27,H28,MMM	1
12	PAFZZ	5310007638919	96906	MS51967-18	.NUT,PLAIN,HEXAGON 9/16-12..... UOC:AVY,A11,A13,A14,A15,A20,A24,A25, A26,A27,B16,B17,B18,HVY,H11,H13,H14, H15,H16,H17,H18,H20,H21,H24,H25,H26, H27,H28,MMM	2
13	PAFZZ	5305000712081	80204	B1821BH050C450N	.SCREW,CAP,HEXAGON H R.H. 1/2-13 X 4.50..... UOC:AVY,A11,A13,A14,A15,A20,A24,A25, A26,A27,B16,B17,B18,HVY,H11,H13,H14, H15,H16,H17,H18,H20,H21,H24,H25,H26, H27,H28,MMM	5
14	PFHZZ	5340011858620	19207	12338178	.BRACKET,ANGLE FRONT,R.H..... UOC:AVY,A11,A13,A14,A15,A20,A24,A25, A26,A27,B16,B17,B18,HVY,H11,H13,H14, H15,H16,H17,H18,H20,H21,H24,H25,H26, H27,H28,MMM	1
15	PBHZZ	2510012491600	19207	12338247	.FRAME,STRUCTURAL,VE R.H..... UOC:AVY,A11,A13,A14,A15,A20,A24,A25, A26,A27,B16,B17,B18,HVY,H11,H13,H14, H15,H16,H17,H18,H20,H21,H24,H25,H26, H27,H28,MMM	1

SECTION II		TM9-2320-280-24P				
(1)	(2)	(3)	(4)	(5)	(6)	(7)
ITEM	SMR			PART		
NO	CODE	NSN	CAGEC	NUMBER	DESCRIPTION AND USABLE ON CODES(UC)	QTY
16	PAHZZ	5340012491575	34623	5594572	.BRACKET,ANGLE R.H..... UOC:HVY,H11,H13,H14,H15,H16,H17,H18, H20,H21,H24,H25,H26,H27,H28,MMM	1
17	PAFZZ	5305000712067	80204	B1821BH050C125N	.SCREW,CAP,HEXAGON H 1/2-13 X 1.25. UOC:AVY,A11,A13,A14,A15,A20,A24,A25, A26,A27,B16,B17,B18,HVY,H11,H13,H14, H15,H16,H17,H18,H20,H21,H24,H25,H26, H27,H28,MMM	3
18	PAHZZ	5340011900333	34623	5582763	.BRACKET,ANGLE REAR..... UOC:AVY,A11,A13,A14,A15,A20,A24,A25, A26,A27,B16,B17,B18,HVY,H11,H13,H14, H15,H16,H17,H18,H20,H21,H24,H25,H26, H27,H28,MMM	2

END OF FIGURE

1 — 2 thru 28

USE WITH A2 VEHICLES

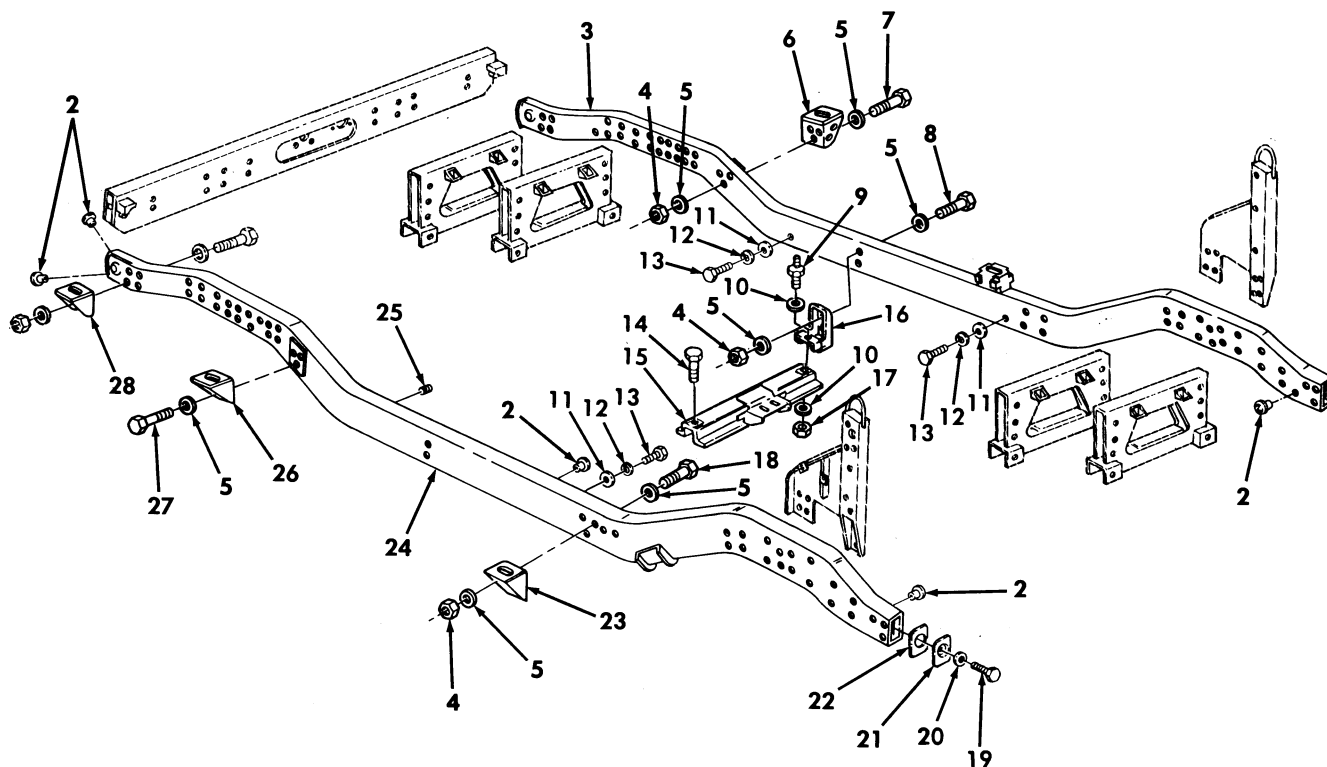

Figure 180. Frame Assembly, Body Mount Brackets, and Transmission Crossmember.



SECTION II			TM9-2320-280-24P			
(1)	(2)	(3)	(4)	(5)	(6)	(7)
ITEM	SMR			PART		
NO	CODE	NSN	CAGEC	NUMBER	DESCRIPTION AND USABLE ON CODES(UOC)	QTY
GROUP 1501 FRAME ASSEMBLY						
FIG. 180 FRAME ASSEMBLY,BODY MOUNT BRACKETS,AND TRANSMISSION CROSSMEMBER						
1	XDHHH		19207	EX5063	FRAME ASSEMBLY.....	2
2	PAOZZ	5340012445765	34623	5597286	UOC:BVY,B15,B20,B24,B25,C17,NNN .PLUG,PROTECTIVE,DUS.....	7
3	PBHZZ	2510014773949	34623	RCSK18810	UOC:BVY,B15,B20,B24,B25,C17,NNN .FRAME SECTION,STRUC L.H.....	1
4	PAFZZ	5310004883889	96906	MS51943-39	UOC:BVY,B15,B20,B24,B25,C17,NNN .NUT,SELF-LOCKING,HE 1/2-13.....	12
5	PAFZZ	5310012538948	34623	5593320	UOC:BVY,B15,B20,B24,B25,C17,NNN .WASHER,FLAT 1/2.....	27
6	PAHZZ	5340013585588	19207	12342509	UOC:BVY,B15,B20,B24,B25,C17,NNN .BRACKET,ANGLE L.H.....	1
7	PAFZZ	5305000712082	80204	B1821BH050C475N	UOC:BVY,B15,B20,B24,B25,C17,NNN .SCREW,CAP,HEXAGON H 1/2-13 X 4.75.	3
8	PAFZZ	5305011857122	34623	5591781	UOC:BVY,B15,B20,B24,B25,C17,NNN .SCREW,CAP,HEXAGON H 1/2-13 X 4.25.	3
9	PAFZZ	5307014503072	19207	12447177	UOC:BVY,B15,B20,B24,B25,C17,NNN .STUD,SHOULDERED.....	1
10	PAFZZ	5310000685285	96906	MS27183-20	UOC:BVY,B15,B20,B24,B25,C17,NNN .WASHER,FLAT 9/16.....	4
11	PAOZZ	5310000814219	96906	MS27183-12	UOC:BVY,B15,B20,B24,B25,C17,NNN .WASHER,FLAT.....	4
12	PAOZZ	5310004079566	96906	MS-35338-45	UOC:BVY,B15,B20,B24,B25,C17,NNN .WASHER,LOCK.....	4
13	PAOZZ	5306002258496	96906	MS90725-31	UOC:BVY,B15,B20,B24,B25,C17,NNN .BOLT,MACHINE.....	4
14	PAFZZ	5305007167680	80204	B1821BH056C150N	UOC:BVY,B15,B20,B24,B25,C17,NNN .SCREW,CAP,HEXAGON H 9/16-12 X 1.50	1
15	PAFZZ	2510014124969	34623	12447053	UOC:BVY,B15,B20,B24,B25,C17,NNN .FRAME SECTION,STRUC.....	1
16	PFFZZ	2590011860863	19207	12338185	UOC:BVY,B15,B20,B24,B25,C17,NNN .BRACKET,VEHICULAR C.....	2
17	PAFZZ	5310000443342	19204	8712289-5	UOC:BVY,B15,B20,B24,B25,C17,NNN .NUT,SELF-LOCKING,HE 9/16-12.....	2
18	PAFZZ	5305000712081	80204	B1821BH050C450N	UOC:BVY,B15,B20,B24,B25,C17,NNN .SCREW,CAP,HEXAGON H 1/2-13 X 4.50.	5
19	PAOZZ	5305000680502	96906	MS90725-6	UOC:BVY,B15,B20,B24,B25,C17,NNN .SCREW,CAP,HEXAGON H.....	2
20	PAFZZ	5310008093078	96906	MS27183-11	UOC:BVY,B15,B20,B24,B25,C17,NNN .WASHER,FLAT.....	2
21	PAFZZ	2510014774388	34623	RCSK18848	UOC:BVY,B15,B20,B24,B25,C17,NNN .PLATE,COVER,FRAME.....	2
22	PAFZZ	5330014769732	34623	RCSK18639	UOC:BVY,B15,B20,B24,B25,C17,NNN .GASKET.....	2
23	PAFZZ	5340011858620	19207	12338178	UOC:BVY,B15,B20,B24,B25,C17,NNN .BRACKET,ANGLE R.H.....	2
24	PAHZZ	2510014773968	34623	RCSK18809	UOC:BVY,B15,B20,B24,B25,C17,NNN .FRAME SECTION,STRUC R.H.....	1

SECTION II			TM9-2320-280-24P			
(1)	(2)	(3)	(4)	(5)	(6)	(7)
ITEM	SMR			PART		
NO	CODE	NSN	CAGEC	NUMBER	DESCRIPTION AND USABLE ON CODES(UC)	QTY
25	PBHZZ	5305014771867	34623	RCSK19027	UOC:BVY,B15,B20,B24,B25,C17,NNN .SETSCREW.....	7
26	PAHZZ	5340013587595	19207	12342510	UOC:BVY,B15,B20,B24,B25,C17,NNN .BRACKET,MOUNTING R.H.....	1
27	PAFZZ	5305000712067	80204	B1821BH050C125N	UOC:BVY,B15,B20,B24,B25,C17,NNN .SCREW,CAP,HEXAGON H 1/2-13 X 1.25.	27
28	PAHZZ	5340011900333	34623	5582763	UOC:BVY,B15,B20,B24,B25,C17,NNN .BRACKET,ANGLE L.H.....	1

END OF FIGURE

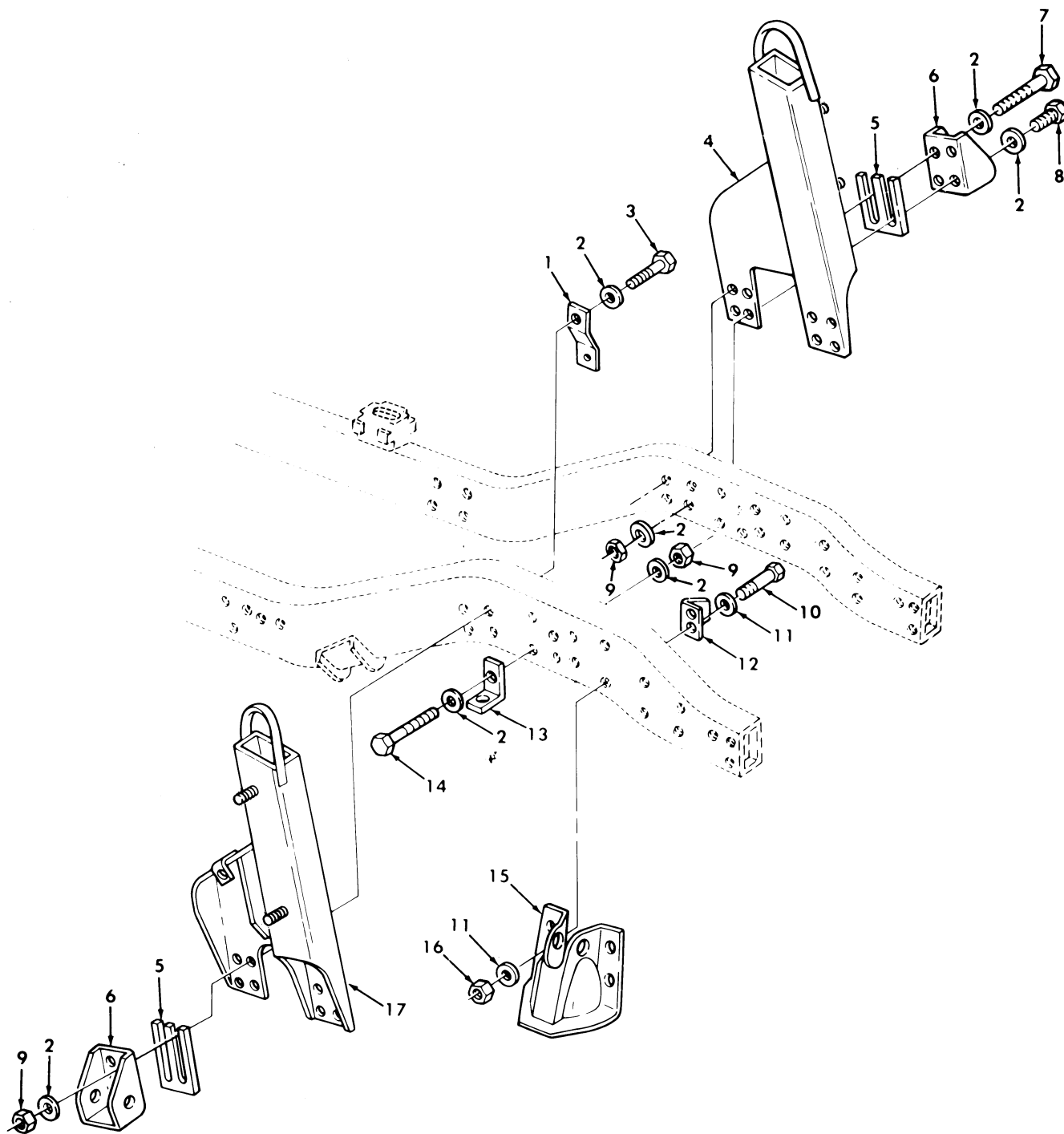

Figure 181. Air Lift Brackets, Front Upper Control Arm Brackets, Front Spring Seats, and Mounting Hardware.

SECTION II			TM9-2320-280-24P			
(1)	(2)	(3)	(4)	(5)	(6)	(7)
ITEM	SMR			PART		
NO	CODE	NSN	CAGEC	NUMBER	DESCRIPTION AND USABLE ON CODES(UC)	QTY
GROUP 1501 FRAME ASSEMBLY						
FIG. 181 AIR LIFT BRACKETS,FRONT UPPER CONTROL ARM BRACKETS,FRONT SPRING SEATS,AND MOUNTING HARDWARE						
1	PAFZZ	5340012142089	19207	12338159	BRACKET,MOUNTING.....	1
2	PAFZZ	5310012538948	34623	5593320	WASHER,FLAT 1/2.....	39
3	PAFZZ	5305000712079	80204	B1821BH050C400N	SCREW,CAP,HEXAGON H 1/2-13 X 4.00..	3
4	PAFZZ	5340013171470	19207	12342361	BRACKET,MOUNTING L.H.....	1
5	PAFZZ	5365012097831	34623	5583219	SPACER,PLATE .060 INCH.....	4
5	PAFZZ	5365012097832	19207	12338226-2	SPACER,PLATE .120 INCH.....	4
6	PAFZZ	2590012154325	19207	12338245	BRACKET,VEHICULAR C FRONT.....	4
7	PAFZZ	5305000712078	80204	B1821BH050C375N	SCREW,CAP,HEXAGON H 1/2-13 X 3.75..	12
8	PAFZZ	5305000712070	80204	B1821BH050C175N	SCREW,CAP,HEXAGON H 1/2-13 X 1.75..	1
9	PAFZZ	5310004883889	96906	MS51943-39	NUT,SELF-LOCKING,HE 1/2-13.....	19
10	PAFZZ	5305009474358	80204	B1821BH075C400N	SCREW,CAP,HEXAGON H 3/4-10 X 4.00..	8
11	PAFZZ	5310012604839	34623	5593312	WASHER,FLAT 3/4.....	16
12	PAFZZ	5340012107966	19207	12338173	BRACKET,ANGLE.....	1
13	PAFZZ	5340011902248	19207	12338170	BRACKET,ANGLE.....	2
14	PAFZZ	5306011867128	7X677	9427162	BOLT,MACHINE 1/2-13 X 3.75.....	4
15	PAFZZ	2540011877034	19207	12338191-1	SEAT SPRING,VEHICUL L.H. FRONT.....	1
15	PAFZZ	2540011883239	19207	12338191-2	SEAT SPRING,VEHICUL R.H.FRONT.....	1
16	PAFZZ	5310004093333	96906	MS51943-45	NUT,SELF-LOCKING,HE 3/4-10.....	8
17	PAFZZ	5340013170147	19207	12342362	BRACKET,MOUNTING R.H., USBL EFF 100,000 AND ABOVE..... UC:AVY,A11,A13,A14,A15,A20,A24,A25, A26,A27,B16,B17,B18,HVY,H11,H13,H14, H15,H16,H17,H18,H20,H21,H24,H25,H26, H27,H28,MMM	1
17	PAFZZ	2590014786799	19207	12447001	AIR LIFT MOUNT R.H..... UC:BVY,B15,B20,B24,B25,C17,NNN	1
17	PAFZZ	2510011757224	34623	5592737	AIR LIFT ASSEMBLY R.H..... UC:H11,H13,H14,H15,H16,H17,H18,H20, H21,H24,H25,H26,H27,H28,MMM	1

END OF FIGURE

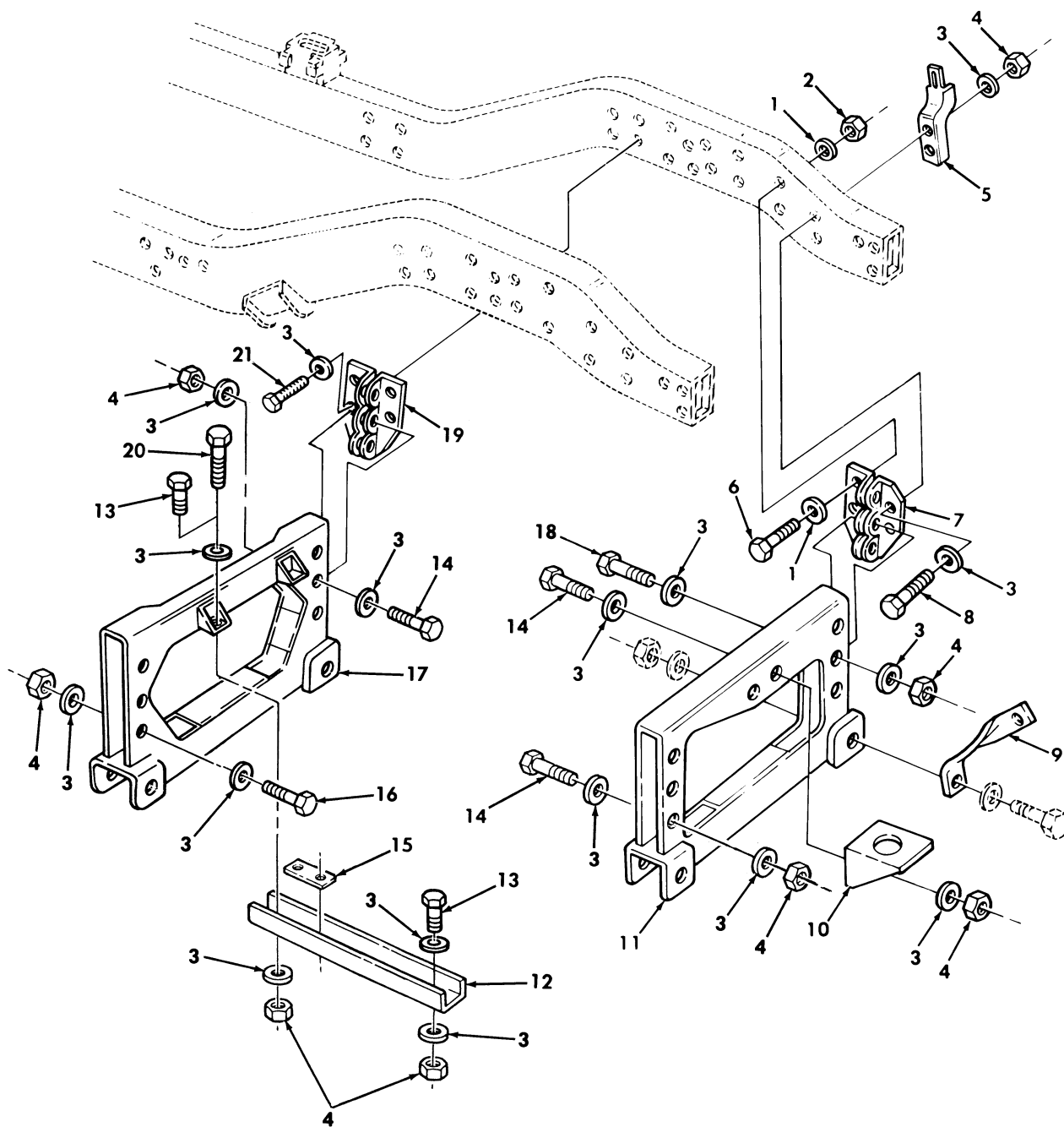

Figure 182. Front Suspension Crossmembers, Related Parts, and Mounting Hardware.

SECTION II			TM9-2320-280-24P			
(1)	(2)	(3)	(4)	(5)	(6)	(7)
ITEM	SMR			PART		
NO	CODE	NSN	CAGEC	NUMBER	DESCRIPTION AND USABLE ON CODES(UOC)	QTY
GROUP 1501 FRAME ASSEMBLY						
FIG. 182 FRONT SUSPENSION CROSS-MEMBERS,RELATED PARTS,AND MOUNTING HARDWARE						
1	PAFZZ	5310012604839	34623	5593312	WASHER,FLAT 3/4.....	8
2	PAFZZ	5310004093333	96906	MS51943-45	NUT,SELF-LOCKING,HE 3/4-10.....	4
3	PAFZZ	5310012538948	34623	5593320	WASHER,FLAT 1/2.....	45
4	PAFZZ	5310004883889	96906	MS51943-39	NUT,SELF-LOCKING,HE 1/2-13.....	22
5	PAFZZ	5340011923414	19207	12338166	BRACKET,MOUNTING.....	2
					UOC:AVY,A11,A13,A14,A15,A20,A24,A25,A26,A27,B16,B17,B18,HVY,H11,H13,H14,H15,H16,H17,H18,H20,H21,H24,H25,H26,H27,H28,MMM	
5	PAFZZ		19207	12447051	BRACKET,MOUNTING.....	2
					UOC:BVY,B15,B20,B24,B25,C17,NNN	
6	PAFZZ	5305009474358	80204	B1821BH075C400N	SCREW,CAP,HEXAGON H 3/4-10 X 4.00..	4
7	PFFZZ	2510011890891	34623	5579620	BRACKET,CROSSMEMBER L.H. FRONT.....	1
7	PFFZZ	2510011877031	34623	5579621	BRACKET,CROSSMEMBER R.H. FRONT.....	1
8	PAFZZ	5305000712076	80204	B1821BH050C325N	SCREW,CAP,HEXAGON H 1/2-13 X 3.25..	4
					UOC:AVY,A11,A13,A14,A15,A20,A24,A25,A26,A27,B16,B17,B18,HVY,H11,H13,H14,H15,H16,H17,H18,H20,H21,H24,H25,H26,H27,H28,MMM	
8	PAFZZ	5305000712079	80204	B1821BH050C400N	SCREW,CAP,HEXAGON H 1/2-13 X 4.00..	4
					UOC:BVY,B15,B20,B24,B25,C17,NNN	
9	PFFZZ	2530012103567	19207	12338165	BRACE,SUSPENSION.....	2
10	PFOZZ	5340012127711	19207	12338180	BRACKET,ANGLE LOWER RADIATOR MOUNT..	1
11	PFFZZ	2510011757216	19207	12338230	FRAME SECTION,STRUC FRONT FORWARD..	1
					UOC:AVY,A11,A13,A14,A15,A20,A24,A25,A26,A27,B16,B17,B18,HVY,H11,H13,H14,H15,H16,H17,H18,H20,H21,H24,H25,H26,H27,H28,MMM	
11	PAFZZ	2510014663752	34623	WA12338230	FRAME,STRUCTURAL,VE FRONT FORWARD..	1
					UOC:BVY,B15,B20,B24,B25,C17,NNN	
12	PFFZZ	2590011856711	19207	12338146	BRACKET,VEHICULAR C.....	2
					UOC:AVY,A11,A13,A14,A15,A20,A24,A25,A26,A27,B16,B17,B18,HVY,H11,H13,H14,H15,H16,H17,H18,H20,H21,H24,H25,H26,H27,H28,MMM	
12	PFFZZ	5340014324876	34623	6002224	BRACKET,AXLE LEFT FRONT.....	1
					UOC:BVY,B15,B20,B24,B25,C17,NNN	
12	PFFZZ	5340014378751	34623	6002225	BRACKET,AXLE RIGHT FRONT.....	1
					UOC:BVY,B15,B20,B24,B25,C17,NNN	
13	PAFZZ	5305000712066	80204	B1821BH050C100N	SCREW,CAP,HEXAGON H.....	4
					UOC:AVY,A11,A13,A14,A15,A20,A24,A25,A26,A27,B16,B17,B18,HVY,H11,H13,H14,H15,H16,H17,H18,H20,H21,H24,H25,H26,H27,H28,MMM	
13	PAFZZ	5305000712069	80204	B1821BH050C150N	SCREW,CAP,HEXAGON H FRONT	2
					CROSSMEMBER.....	
					UOC:BVY,B15,B20,B24,B25,C17,NNN	

SECTION II			TM9-2320-280-24P			
(1)	(2)	(3)	(4)	(5)	(6)	(7)
ITEM	SMR			PART		
NO	CODE	NSN	CAGEC	NUMBER	DESCRIPTION AND USABLE ON CODES(UOC)	QTY
14	PAFZZ	5305000712075	80204	B1821BH050C300N	SCREW,CAP,HEXAGON H.....	8
15	PAFZZ	5340014324877	34623	RCSK17122	PLATE,MOUNTING.....	2
					UOC:BVY,B15,B20,B24,B25,C17,NNN	
16	PAFZZ	5305000712076	80204	B1821BH050C325N	SCREW,CAP,HEXAGON H 1/2-13 X 3.25..	2
17	PAFZZ	2510011757219	19207	12338223	FRAME SECTION,STRUC FRONT REAR.....	1
					UOC:AVY,A11,A13,A14,A15,A20,A24,A25,A26,A27,B16,B17,B18,HVY,H11,H13,H14,H15,H16,H17,H18,H20,H21,H24,H25,H26,H27,H28,MMM	
17	PAFZZ	2510014138045	34623	WA12338223	FRAME SECTION,STRUC.....	1
					UOC:BVY,B15,B20,B24,B25,C17,NNN	
18	PAFZZ	5305000712074	80204	B1821BH050C275N	SCREW,CAP,HEXAGON H 1/2-13 X 2.75..	4
19	PFFZZ	2510011856647	34623	12338155-1	BRACKET,CROSSMEMBER L.H.REAR.....	1
19	PFFZZ	2510011856648	34623	12338155-2	BRACKET,CROSSMEMBER R.H.REAR.....	1
20	PAFZZ	5305000712067	80204	B1821BH050C125N	SCREW,CAP,HEXAGON H 1/2-13 X 1.25..	2
					UOC:BVY,B15,B20,B24,B25,C17,NNN	
21	PAFZZ	5305000712066	80204	B1821BH050C100N	SCREW,CAP,HEXAGON H.....	1

END OF FIGURE

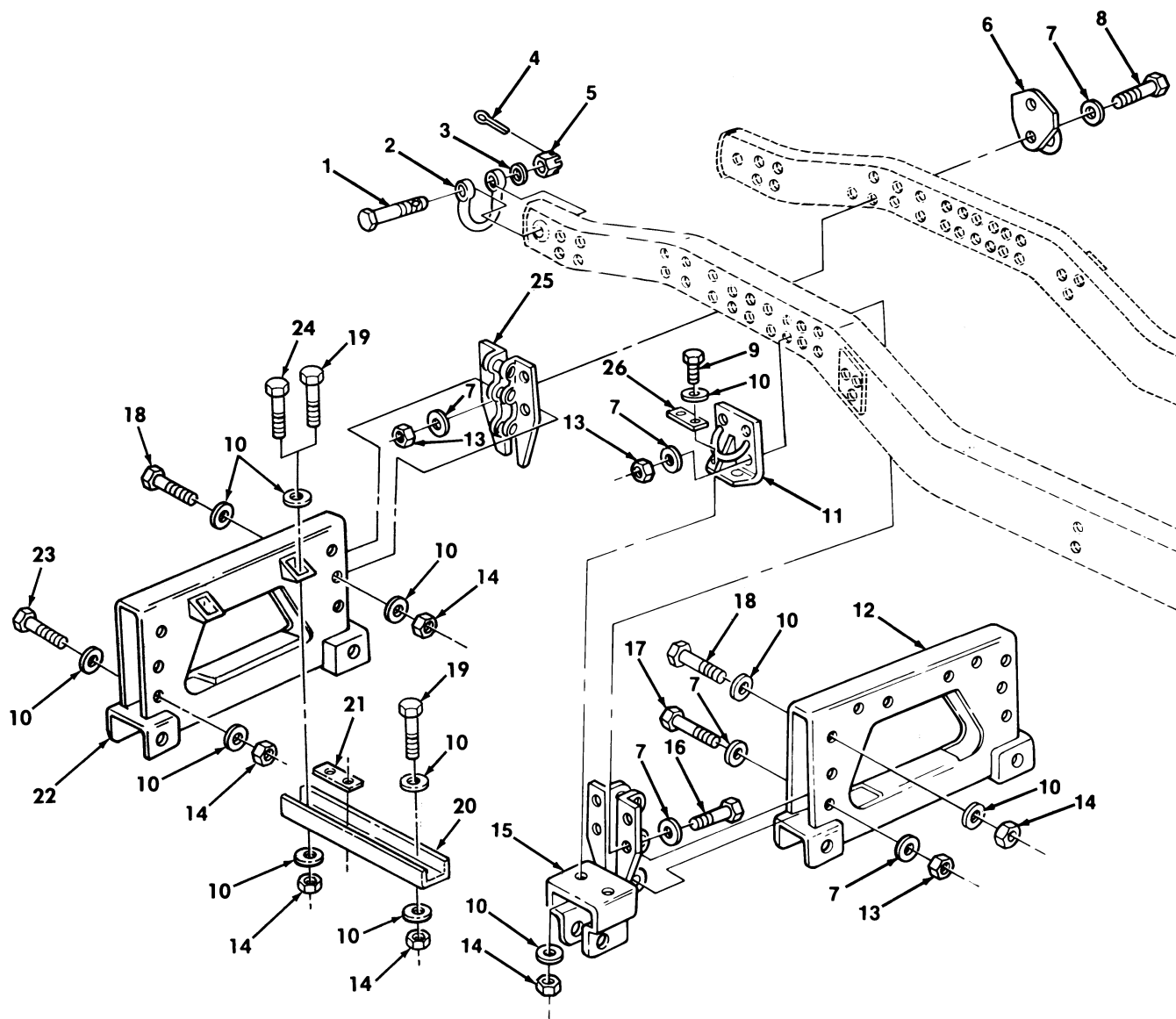

Figure 183. Rear Suspension Crossmembers, Related Parts, and Mounting Hardware.



SECTION II			TM9-2320-280-24P			
(1)	(2)	(3)	(4)	(5)	(6)	(7)
ITEM	SMR			PART		
NO	CODE	NSN	CAGEC	NUMBER	DESCRIPTION AND USABLE ON CODES(UOC)	QTY
GROUP 1501 FRAME ASSEMBLY						
FIG. 183 REAR SUSPENSION CROSS-MEMBERS,RELATED PARTS,AND MOUNTING HARDWARE						
1	PAOZZ	5305012643602	19207	12338225-1	SCREW,CAP,HEXAGON H REAR LIFTING SHACKLE,5/8-18 X 5.50.....	2
					UOC:A11,A13,A14,A20,A24,A25,A26,A27,B17,B20,B24,B25,C17,H11,H13,H14,H17,H18,H20,H24,H25,H26,H27,MMM	
2	PAOZZ	4030013161551	19207	12342354	SHACKLE REAR.....	2
					UOC:A11,A13,A14,A20,A24,A25,A26,A27,B17,B20,B24,B25,C17,H11,H13,H14,H17,H18,H20,H24,H25,H26,H27,MMM	
3	PAOZZ	5310005957486	77820	10-40704-22	WASHER,SPRING TENSI 5/8.....	2
					UOC:A11,A13,A14,A20,A24,A25,A26,A27,B17,B20,B24,B25,C17,H11,H13,H14,H17,H18,H20,H24,H25,H26,H27,MMM	
4	PAOZZ	5315000120123	96906	MS24665-355	PIN,COTTER 1/8 X 1.25.....	2
					UOC:A11,A13,A14,A20,A24,A25,A26,A27,B17,B20,B24,B25,C17,H11,H13,H14,H17,H18,H20,H24,H25,H26,H27,MMM	
5	PAOZZ	5310008507004	96906	MS35692-54	NUT,PLAIN,SLOTTED,H 5/8-18.....	2
					UOC:A11,A13,A14,A20,A24,A25,A26,A27,B17,B20,B24,B25,C17,H11,H13,H14,H17,H18,H20,H24,H25,H26,H27,MMM	
6	PPFZZ	5340011867664	19207	12338181	LOOP,STRAP FASTENER.....	2
7	PAFZZ	5310011474052	24617	2436168	WASHER,FLAT 3/4.....	24
8	PAFZZ	5305009474359	80204	B1821BH075C425N	SCREW,CAP,HEXAGON H 3/4-10 X 4.25..	4
9	PAFZZ	5305000712069	80204	B1821BH050C150N	SCREW,CAP,HEXAGON H 1/2-13 X 1.50..	4
10	PAFZZ	4030013161551	06032	32100143001	WASHER 1/2.....	30
11	PPFZZ	5340012042584	19207	12338197	BRACKET,MOUNTING.....	2
12	PBFZZ	2510011757217	19207	12338217	FRAME SECTION,STRUC REAR FRONT.....	1
					UOC:AVY,A11,A13,A14,A15,A20,A24,A25,A26,A27,B16,B17,B18,HVY,H11,H13,H14,H15,H16,H17,H18,H20,H21,H24,H25,H26,H27,H28,MMM	
12	PBFZZ	2510014334421	34623	RCSK17176	FRAME SECTION,STRUC REAR FRONT.....	1
					UOC:BVY,B15,B20,B24,B25,C17,NNN	
13	PAFZZ	5310004093333	96906	MS51943-45	NUT,SELF-LOCKING,HE 3/4-10.....	12
14	PAFZZ	5310004883889	96906	MS51943-39	NUT,SELF-LOCKING,HE 1/2-13.....	16
15	PPFZZ	2510012106941	19207	12338224	BRACKET,SUSPENSION, REAR.....	2
16	PAFZZ	5305009474360	80204	B1821BH075C450N	SCREW,CAP,HEXAGON H 3/4-10 X 4.50..	4
17	PAFZZ	5305009474355	80204	B1821BH075C325N	SCREW,CAP,HEXAGON H 3/4-10 X 3.25..	4
18	PAFZZ	5305000712074	80204	B1821BH050C275N	SCREW,CAP,HEXAGON H 1/2-13 X 2.75..	6
19	PAFZZ	5305000712066	80204	B1821BH050C100N	SCREW,CAP,HEXAGON H 1/2-13 X 1.00..	4
					UOC:AVY,A11,A13,A14,A15,A20,A24,A25,A26,A27,B16,B17,B18,HVY,H11,H13,H14,H15,H16,H17,H18,H20,H21,H24,H25,H26,H27,H28,MMM	
19	PAFZZ	5305000712067	80204	B1821BH050C125N	SCREW,CAP,HEXAGON H REAR FRONT CROSSMEMBER 1/3-13 X 1.25.....	2

SECTION II			TM9-2320-280-24P			
(1)	(2)	(3)	(4)	(5)	(6)	(7)
ITEM NO	SMR CODE	NSN	CAGEC	PART NUMBER	DESCRIPTION AND USABLE ON CODES(UOC)	QTY
20	PFFZZ	5340014328678	34623	6002226	UOC:BVY,B15,B20,B24,B25,C17,NNN BRACKET,VEHICULAR C LEFT REAR.....	1
20	PFFZZ	5340014378748	34623	6002227	UOC:BVY,B15,B20,B24,B25,C17,NNN BRACKET,VEHICULAR C RIGHT REAR.....	1
20	PFFZZ	2590011856711	19207	12338146	UOC:BVY,B15,B20,B24,B25,C17,NNN BRACKET,VEHICULAR C REAR.....	2
21	PAFZZ	5340014332743	34623	RCSK17123	UOC:AVY,A11,A13,A14,A15,A20,A24,A25, A26,A27,B16,B17,B18,HVY,H11,H13,H14, H15,H16,H17,H18,H20,H21,H24,H25,H26, H27,H28,MMM PLATE,MOUNTING.....	2
22	PFFZZ	2510011757218	19207	12338222	UOC:BVY,B15,B20,B24,B25,C17,NNN FRAME SECTION,STRUC REAR.....	1
22	PFFZZ	2510014570949	34623	RCSK17876	UOC:AVY,A11,A13,A14,A15,A20,A24,A25, A26,A27,B16,B17,B18,HVY,H11,H13,H14, H15,H16,H17,H18,H20,H21,H24,H25,H26, H27,H28,MMM FRAME SECTION,STRUC REAR.....	2
23	PAFZZ	5305000712075	80204	B1821BH050C300N	UOC:BVY,B15,B20,B24,B25,C17,NNN SCREW,CAP,HEXAGON H 1/2-13 X 3.00..	2
24	PAFZZ	5305000712069	80204	B1821BH050C150N	UOC:BVY,B15,B20,B24,B25,C17,NNN SCREW,CAP,HEXAGON H.....	2
25	PFFZZ	2510011877033	19207	12338148	UOC:BVY,B15,B20,B24,B25,C17,NNN FRAME SECTION,STRUC REAR.....	2
26	PFOZZ	5340012097767	19207	12338172	UOC:BVY,B15,B20,B24,B25,C17,NNN PLATE,MENDING.....	2

END OF FIGURE

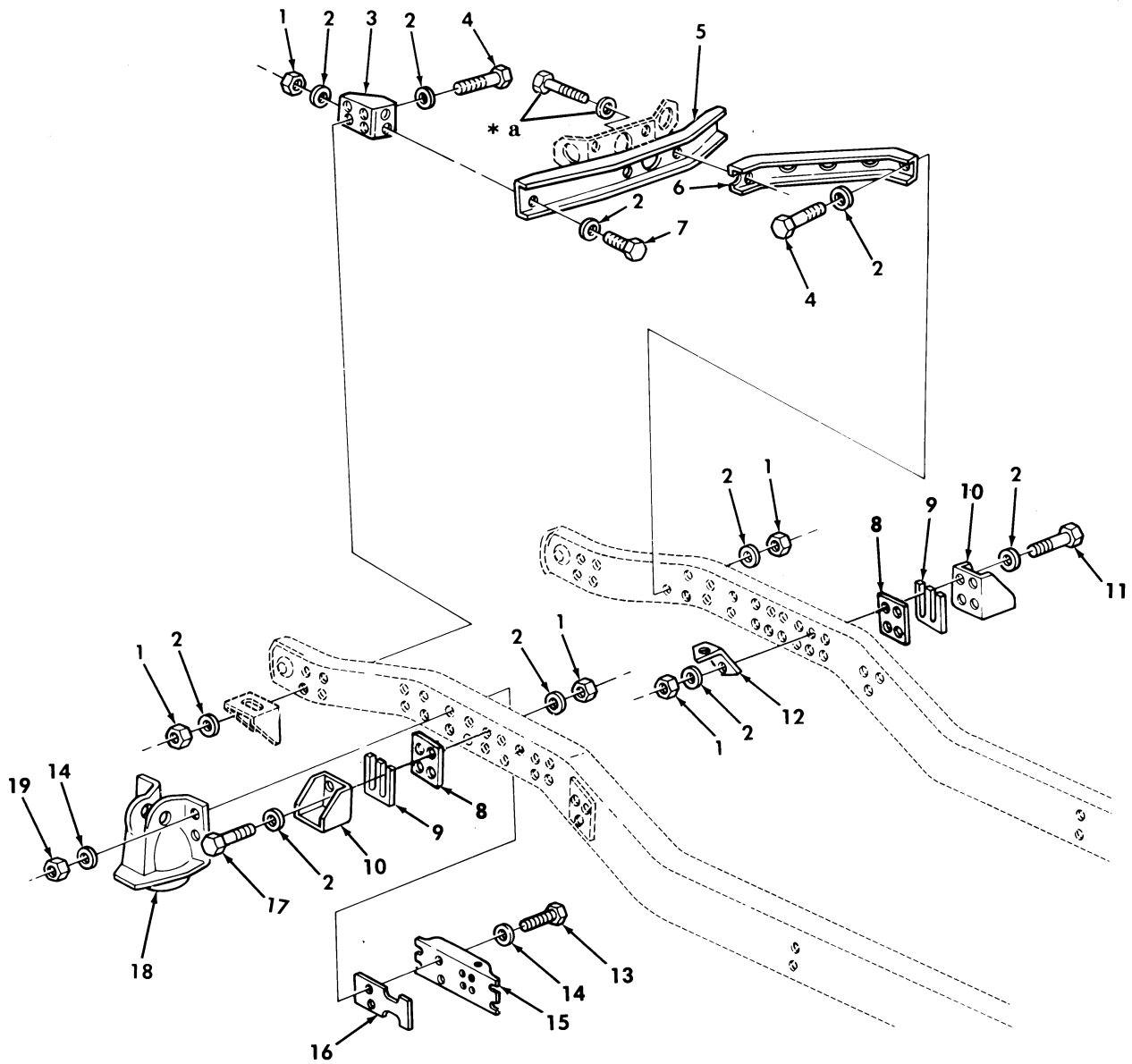

\* a FOR CALLOUT SEE FIGURE 191

Figure 184. Upper Control Arm Brackets, Spring Seats, Related Parts, and Mounting Hardware.

SECTION II			TM9-2320-280-24P			
(1)	(2)	(3)	(4)	(5)	(6)	(7)
ITEM	SMR			PART		
NO	CODE	NSN	CAGEC	NUMBER	DESCRIPTION AND USABLE ON CODES(UOC)	QTY
GROUP 1501 FRAME ASSEMBLY						
FIG. 184 UPPER CONTROL ARM BRACKETS, SPRING SEATS,RELATED PARTS,AND MOUNTING HARDWARE						
1	PAOZZ	5310004883889	96906	MS51943-39	NUT,SELF-LOCKING,HE 1/2-13.....	16
					UOC:AVY,A15,BVY,B15,B16,B20,B24,B25,C17,HVY,H15,H16,H21,H28,NNN	
1	PAOZZ	5310004883889	96906	MS51943-39	NUT,SELF-LOCKING,HE 1/2-13.....	30
					UOC:A11,A13,A14,A20,A24,A25,A26,A27,B17,B18,H11,H13,H14 H17,H18,H20,H24,H25,H26,H27,MMM	
2	PAOZZ	5310011211703	06032	2310-0143-001	WASHER,FLAT 1/2.....	60
					UOC:A11,A13,A14,A20,A24,A25,A26,A27,B17,B18,H11,H13,H14 H17,H18,H20,H24,H25,H26,H27,MMM	
2	PAOZZ	5310011211703	11862	2436165	WASHER,FLAT 1/2.....	32
					UOC:AVY,A15,BVY,B15,B16,B20,B24,B25,C17,HVY,H15,H16,H21,H28,NNN	
3	PFFZZ	2590011844475	19207	12338167-1	BRACKET,VEHICULAR C REAR BUMPER,LH.	1
					UOC:A11,A13,A14,A20,A24,A25,A26,A27,B17,B18,H11,H13,H14 H17,H18,H20,H24,H25,H26,H27,MMM	
3	PFFZZ	5340013616658	19207	12338167-2	BRACKET,MOUNTING R.H.....	1
					UOC:A11,A13,A14,A20,A24,A25,A26,A27,B17,B18,H11,H13,H14 H17,H18,H20,H24,H25,H26,H27,MMM	
4	PAOZZ	5305000712078	80204	B1821BH050C375N	SCREW,CAP,HEXAGON H 1/2-13 X 3.75..	10
					UOC:A11,A13,A14,A20,A24,A25,A26,A27,B17,B18,H11,H13,H14 H17,H18,H20,H24,H25,H26,H27,MMM	
5	PFOZZ	9520011757222	19207	12338193	CHANNEL,STRUCTURAL.....	1
					UOC:A11,A13,A14,A20,A24,A25,A26,A27,B17,B18,H11,H13,H14 H17,H18,H20,H24,H25,H26,H27,MMM	
6	PFOZZ	2510011890890	34623	5579538	FRAME SECTION,STRUC.....	2
					UOC:A11,A13,A14,A20,A24,A25,A26,A27,B17,B18,H11,H13,H14 H17,H18,H20,H24,H25,H26,H27,MMM	
7	PAOZZ	5305000712067	80204	B1821BH050C125N	SCREW,CAP,HEXAGON H 1/2-13 X 1.25..	4
					UOC:A11,A13,A14,A20,A24,A25,A26,A27,B17,B18,H11,H13,H14 H17,H18,H20,H24,H25,H26,H27,MMM	
8	PAFZZ	5365012101628	19207	12338171	SPACER,PLATE.....	4
9	PAFZZ	5365012097831	34623	5583219	SPACER,PLATE .060 INCH.....	4
9	PAFZZ	5365012097832	19207	12338226-2	SPACER,PLATE .120 INCH.....	4
10	PFFZZ	2530011891745	19207	12338240	ARM,CONTROL,VEHICUL UPPER CONTROL ARM.....	4
11	PAFZZ	5305011857122	34623	5591781	SCREW,CAP,HEXAGON H 1/2-13 X 4.25..	8
12	PFFZZ	5340012097767	19207	12338172	PLATE,MENDING.....	1
13	PAFZZ	5305009474360	80204	B1821BH075C450N	SCREW,CAP,HEXAGON H 3/4-10 X 4.50..	8

SECTION II			TM9-2320-280-24P			
(1)	(2)	(3)	(4)	(5)	(6)	(7)
ITEM	SMR			PART		
NO	CODE	NSN	CAGEC	NUMBER	DESCRIPTION AND USABLE ON CODES(UC)	QTY
14	PAFZZ	5310012604839	34623	5593312	WASHER,FLAT 3/4.....	16
15	PFFZZ	2510012039883	19207	12338152	FRAME,STRUCTURAL,VE.....	2
16	PFFZZ	2510012106942	34623	12338174	PLATE,REINFORCEMENT.....	2
17	PAFZZ	5305000712081	80204	B1821BH050C450N	SCREW,CAP,HEXAGON H 1/2-13 X 4.50..	8
18	PFFZZ	2540012035664	19207	12338190	SEAT,SPRING VEHICUL.....	2
					UOC:H11,H13,H14,H17,H18,H20,H24,H25, H26,H27,H28,MMM	
18	PFFZZ	2530012484873	19207	12338738	ARM,CONTROL,VEHICUL REAR,HEAVY DUTY	2
					UOC:AVY,A11,A13,A14,A15,A20,A24,A25, A26,A27,BVY,B15,B16,B17,B18,B20,B24, B25,C17,HVY,H15,H16,H21,H28,NNN	
19	PFFZZ	5310004093333	96906	MS51943-45	NUT,SELF-LOCKING,HE 3/4-10.....	8

END OF FIGURE

**USE WITH BASIC AND A1 VEHICLES**

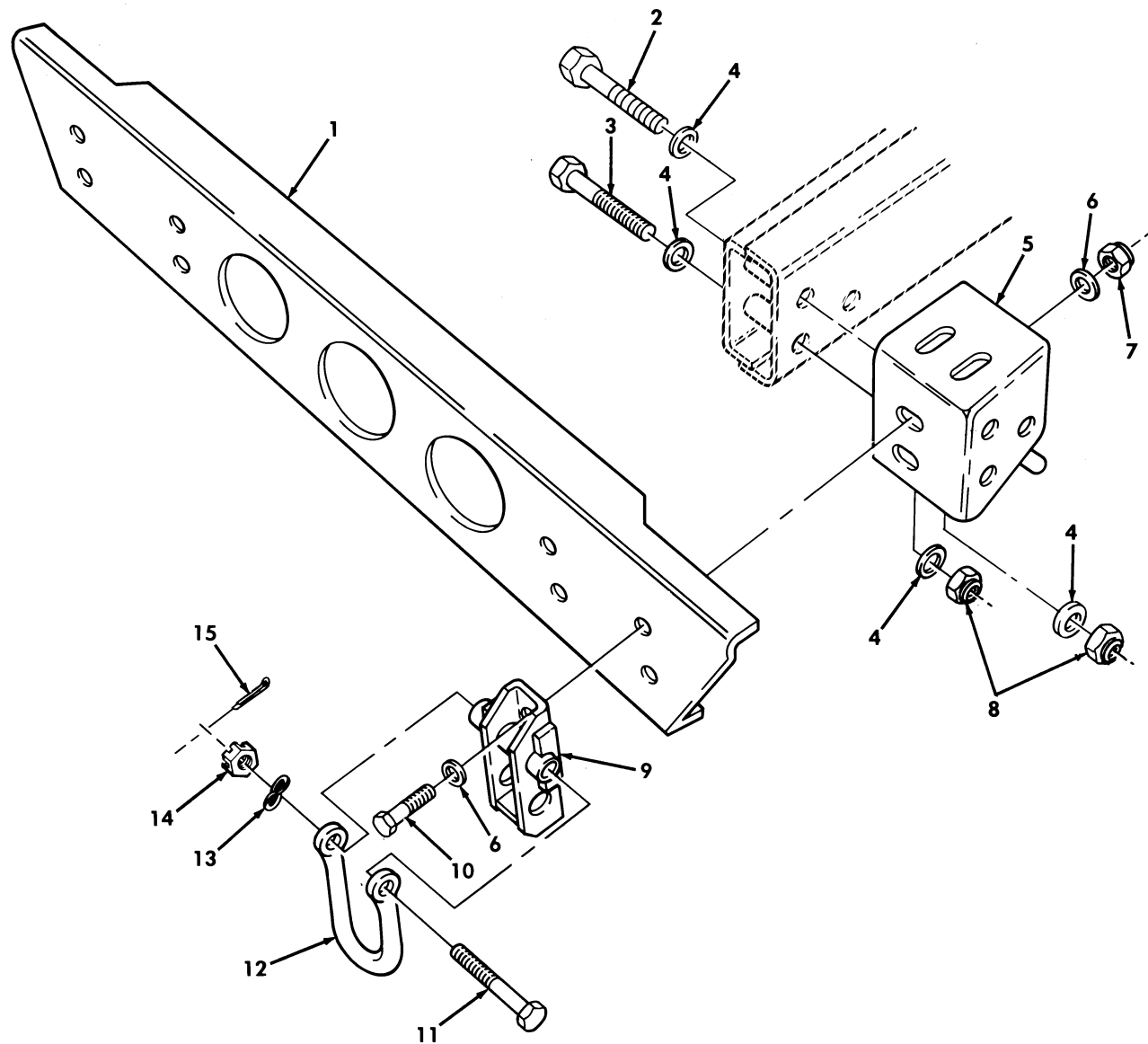

*Figure 185. Front Bumper and Lifting Shackle.*

SECTION II			TM9-2320-280-24P			
(1)	(2)	(3)	(4)	(5)	(6)	(7)
ITEM NO	SMR CODE	NSN	CAGEC	PART NUMBER	DESCRIPTION AND USABLE ON CODES(UC)	QTY
GROUP 1501 FRAME ASSEMBLY						
FIG. 185 FRONT BUMPER AND LIFTING SHACKLE						
1	PAOZZ	2540011891074	19207	12338426	BUMPER,VEHICULAR FRONT..... UOC:AVY,A11,A13,A15,A20,A24,A25,B16, B17,HVY,H11,H13,H15,H16,H17,H20,H21, H24,H25,MMM	1
2	PAOZZ	5305012550094	7X677	9427812	SCREW,CAP,HEXAGON H 5/8-11 X 3.25.. UOC:AVY,A11,A13,A15,A20,A24,A25,B16, B17,HVY,H11,H13,H15,H16,H17,H20,H21, H24,H25,MMM	2
3	PAOZZ	5305007247247	80204	B1821BH063C350N	SCREW,CAP,HEXAGON H 5/8-11 X 3.50.. UOC:AVY,A11,A13,A15,A20,A24,A25,B16, B17,HVY,H11,H13,H15,H16,H17,H20,H21, H24,H25,MMM	4
4	PAOZZ	5310011517347	24617	2436167	WASHER,FLAT 5/8..... UOC:AVY,A11,A13,A15,A20,A24,A25,B16, B17,HVY,H11,H13,H15,H16,H17,H20,H21, H24,H25,MMM	12
5	PAOZZ	2540011860501	19207	12338199	BRACKET,BUMPER MOUN FRONT..... UOC:AVY,A11,A13,A15,A20,A24,A25,B16, B17,HVY,H11,H13,H15,H16,H17,H20,H21, H24,H25,MMM	2
6	PAOZZ	5310011211703	7X677	2436165	WASHER,FLAT 1/2..... UOC:AVY,A11,A13,A15,A20,A24,A25,B16, B17,HVY,H11,H13,H15,H16,H17,H20,H21, H24,H25,MMM	8
7	PAOZZ	5310004883889	96906	MS51943-39	NUT,SELF-LOCKING,HE 1/2-13..... UOC:AVY,A11,A13,A15,A20,A24,A25,B16, B17,HVY,H11,H13,H15,H16,H17,H20,H21, H24,H25,MMM	4
8	PAOZZ	5310000614651	96906	MS51943-43	NUT,SELF-LOCKING,HE 5/8-11..... UOC:AVY,A11,A13,A15,A20,A24,A25,B16, B17,HVY,H11,H13,H15,H16,H17,H20,H21, H24,H25,MMM	6
9	PAOZZ	2540011856710	19207	12338425	BRACKET WELDMENT,TO USBL EFF 1 THRU 99,999..... UOC:H11,H13,H15,H16,H17,H20,H21,H24, H25,MMM	2
9	PAOZZ	2590013160084	19207	12342404	BRACKET,VEHICULAR C USBL EFF 100, 000 AND ABOVE..... UOC:AVY,A13,A14,A15,A20,A24,A25,B16, B17	2
10	PAOZZ	5305000712071	80204	B1821BH050C200N	SCREW,CAP,HEXAGON H FRONT 1/2-13 X 200..... UOC:AVY,A11,A13,A15,A20,A24,A25,B16, B17,HVY,H11,H13,H15,H16,H17,H20,H21, H24,H25,MMM	4
11	PAOZZ	5305012643602	19207	12338225-1	SCREW,CAP,HEXAGON H 5/8-18 X 5.50.. UOC:AVY,A11,A13,A15,A20,A24,A25,B16, B17,HVY,H11,H13,H15,H16,H17,H20,H21,	2

SECTION II			TM9-2320-280-24P			
(1)	(2)	(3)	(4)	(5)	(6)	(7)
ITEM	SMR			PART		
NO	CODE	NSN	CAGEC	NUMBER	DESCRIPTION AND USABLE ON CODES(UC)	QTY
12	PAOZZ	4030013161551	19207	12342354	H24, H25, MMM SHACKLE.....	2
					UOC:AVY, A11, A13, A15, A20, A24, A25, B16, B17, HVY, H11, H13, H15, H16, H17, H20, H21, H24, H25, MMM	
13	PAOZZ	5310005957486	77820	10-40704-22	WASHER, SPRING TENS I 49/64 I.D.....	2
					UOC:AVY, A11, A13, A15, A20, A24, A25, B16, B17, HVY, H11, H13, H15, H16, H17, H20, H21, H24, H25, MMM	
14	PAOZZ	5310008507004	96906	MS35692-54	NUT, PLAIN, SLOTTED, H 5/8-18.....	2
					UOC:AVY, A11, A13, A15, A20, A24, A25, B16, B17, HVY, H11, H13, H15, H16, H17, H20, H21, H24, H25, MMM	
15	PAOZZ	5315000120123	96906	MS24665-355	PIN, COTTER 1/8 X 1.25.....	2
					UOC:AVY, A11, A13, A15, A20, A24, A25, B16, B17, HVY, H11, H13, H15, H16, H17, H20, H21, H24, H25, MMM	

END OF FIGURE



**USE WITH A2 VEHICLES**

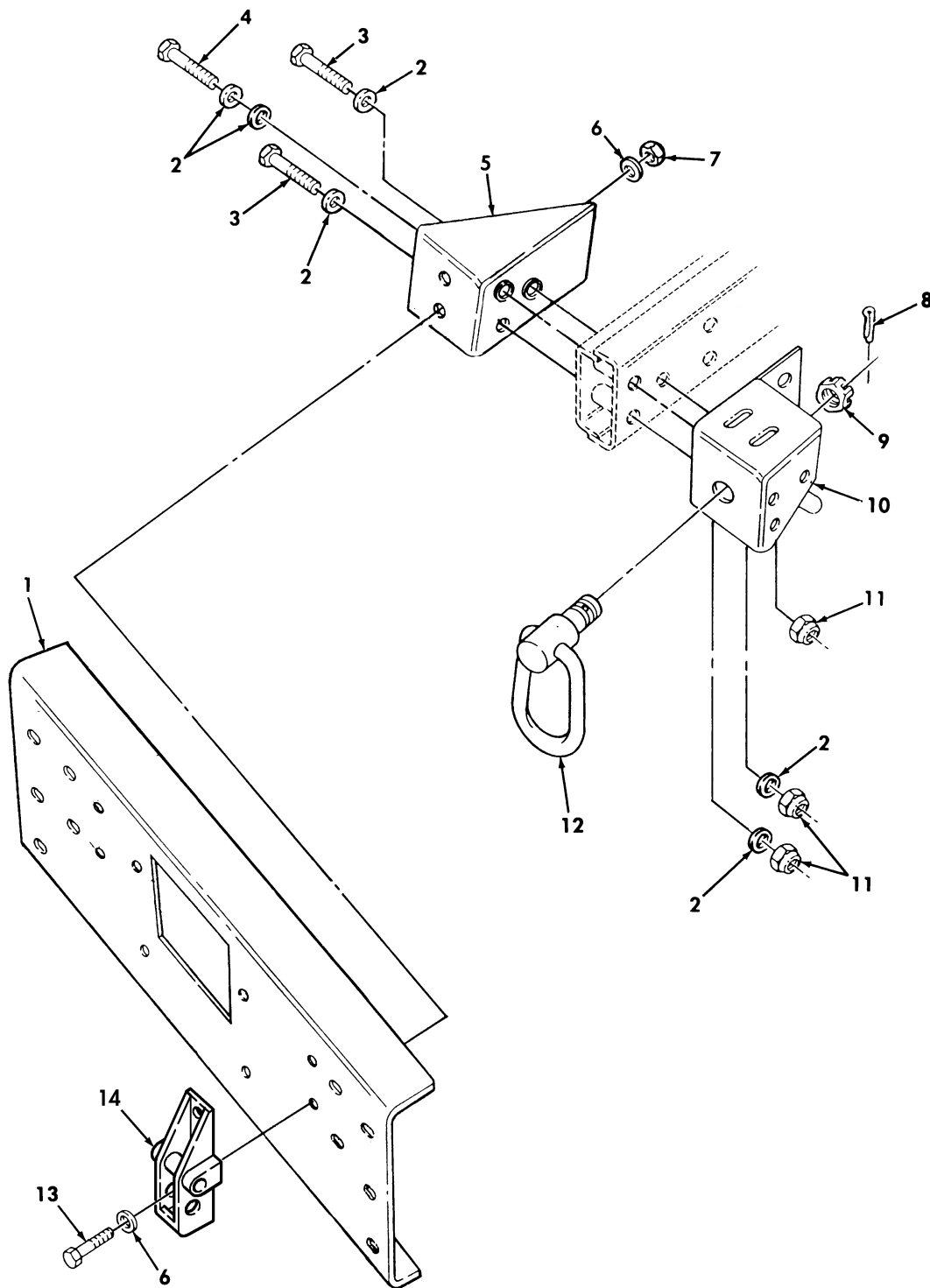

*Figure 186. Front Bumper and Lifting Shackle.*

SECTION II			TM9-2320-280-24P			
(1)	(2)	(3)	(4)	(5)	(6)	(7)
ITEM	SMR			PART		
NO	CODE	NSN	CAGEC	NUMBER	DESCRIPTION AND USABLE ON CODES(UOC)	QTY
GROUP 1501 FRAME ASSEMBLY						
FIG. 186 FRONT BUMPER AND LIFTING SHACKLE						
1	PAOZZ	2540014128610	19207	12447091	BUMPER,VEHICULAR FRONT.....	1
					UOC:BVY,B15,B20,B24,B25,C17,NNN	
2	PAOZZ	5310011211703	24617	2436165	WASHER,FLAT.....	12
					UOC:BVY,B15,B20,B24,B25,C17,NNN	
3	PAOZZ	5305007247254	80204	B1821BH063C400N	SCREW,CAP,HEXAGON H.....	6
					UOC:BVY,B15,B20,B24,B25,C17,NNN	
4	PAOZZ	5305007247248	80204	B1821BH063C375N	SCREW,CAP,HEXAGON H 5/8-11 X 3.75..	2
					UOC:BVY,B15,B20,B24,B25,C17,NNN	
5	PAOZZ	2590014129570	19207	12447100	BRACKET,VEHICULAR C FRONT,R.H.....	1
					UOC:BVY,B15,B20,B24,B25,C17,NNN	
5	PAOZZ	2590014123862	19207	12447101	BRACKET,VEHICULAR C FRONT,L.H.....	1
					UOC:BVY,B15,B20,B24,B25,C17,NNN	
6	PAOZZ	5310011211703	06032	23100143-001	WASHER,FLAT 1/2.....	8
					UOC:BVY,B15,B20,B24,B25,C17,NNN	
7	PAOZZ	5310004883889	96906	MS51943-39	NUT,SELF-LOCKING,HE 1/2-13.....	4
					UOC:BVY,B15,B20,B24,B25,C17,NNN	
8	PAOZZ	5315002398032	80205	MS24665-513	PIN,COTTER FRONT,1/8 X 1.25.....	2
					UOC:BVY,B15,B20,B24,B25,C17,NNN	
9	PAOZZ		24617	9429395	NUT,PLAIN,CASTELLAT 5/8-18.....	2
					UOC:BVY,B15,B20,B24,B25,C17,NNN	
10	PAOZZ	2590014129560	34623	12447093	BRACKET,VEHICULAR C OUTER FRONT,	1
					L.H.....	
					UOC:BVY,B15,B20,B24,B25,C17,NNN	
10	PAOZZ	2590014127564	19207	12447092	BRACKET,VEHICULAR C OUTER FRONT,	1
					R.H.....	
					UOC:BVY,B15,B20,B24,B25,C17,NNN	
11	PAOZZ	5310000614651	96906	MS51943-43	NUT,SELF-LOCKING,HE 5/8-11.....	6
					UOC:BVY,B15,B20,B24,B25,C17,NNN	
12	PAOZZ	5340014130282	19207	12447089-1	CONNECTOR,ROD END FRONT.....	2
					UOC:BVY,B15,B20,B24,B25,C17,NNN	
13	PAOZZ	5305000712070	80204	B1821BH050C175N	SCREW,CAP,HEXAGON H 1/2-13 X 1.75..	4
					UOC:BVY,B15,B20,B24,B25,C17,NNN	
14	PAOZZ	2590013160084	34623	12342404	BRACKET,VEHICULAR C.....	2
					UOC:BVY,B15,B20,B24,B25,C17,NNN	

END OF FIGURE

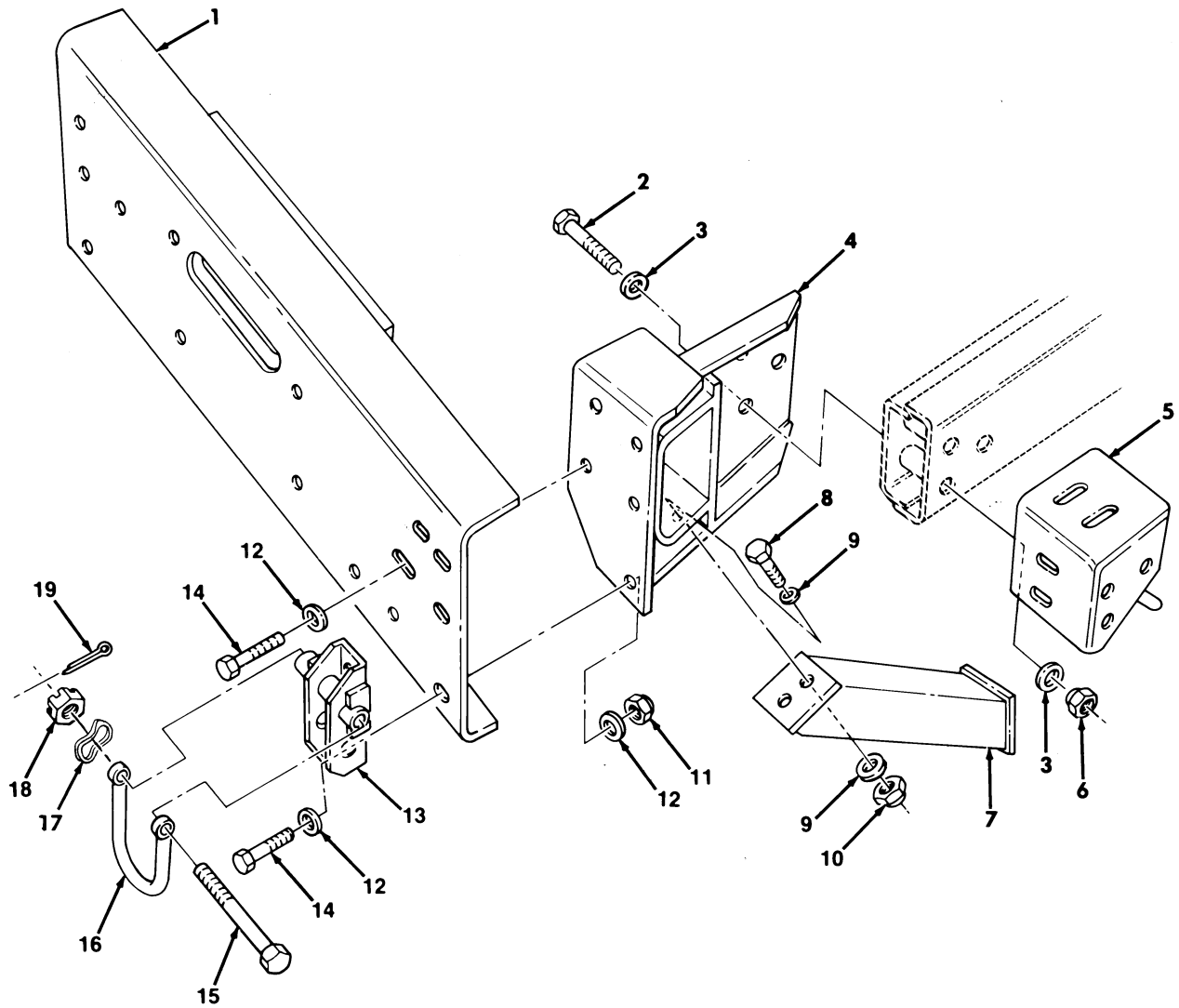

Figure 187. Front Bumper and Lifting Shackle, Winch.

SECTION II			TM9-2320-280-24P			
(1)	(2)	(3)	(4)	(5)	(6)	(7)
ITEM	SMR			PART		
NO	CODE	NSN	CAGEC	NUMBER	DESCRIPTION AND USABLE ON CODES(UOC)	QTY
GROUP 1501 FRAME ASSEMBLY						
FIG. 187 FRONT BUMPER AND LIFTING SHACKLE,WINCH						
1	PAOZZ	2540013618206	19207	12342395	BUMPER,VEHICULAR USBL EFF 100,000 AND ABOVE.....	1
					UOC:A14,A26,A27,B18,H14,H18,H26,H27,H28	
1	PAOZZ	2540011853197	19207	12338482	BUMPER,VEHICULAR USBL EFF 1 THRU 99,999.....	1
					UOC:H14,H18,H26,H27,H28,MMM	
2	PAOZZ	5305011112774	24617	9428039	SCREW,CAP,HEXAGON H 5/8-11 X 3.75..	6
					UOC:A14,A26,A27,B18,H14,H18,H26,H27,H28	
3	PAOZZ	5310011517347	24617	2436167	WASHER,FLAT 5/8.....	12
					UOC:A14,A26,A27,B18,H14,H18,H26,H27,H28	
4	PFOZZ	2510013578789	19207	12342388	FRAME SECTION,STRUC R.H.....	1
					UOC:A14,A26,A27,B18,H14,H18,H26,H27,H28	
4	PFOZZ	2510013581178	19207	12342387	FRAME SECTION,STRUC L.H.....	1
					UOC:A14,A26,A27,B18,H14,H18,H26,H27,H28	
5	PFOZZ	2540011860501	19207	12338199	BRACKET,BUMPER MOUN FRONT.....	2
					UOC:A14,A26,A27,B18,H14,H18,H26,H27,H28	
6	PAOZZ	5310000614651	96906	MS51943-43	NUT,SELF-LOCKING,HE 5/8-11.....	6
					UOC:A14,A26,A27,B18,H14,H18,H26,H27,H28	
7	PFFZZ	2510013581176	19207	12342389	FRAME SECTION,STRUC L.H.,USBL EFF 100,000 AND ABOVE.....	1
					UOC:A14,A26,A27,B18,H14,H18,H26,H27,H28	
7	PFFZZ	2510013581177	19207	12342390	FRAME SECTION,STRUC R.H.,USBL EFF 100,000 AND ABOVE.....	1
					UOC:A14,A26,A27,B18,H14,H18,H26,H27,H28	
8	PAFZZ	5305011044846	24617	9427321	SCREW,CAP,HEXAGON H 3/8-16 X 1.00 , USBL EFF 100,000 AND ABOVE.....	4
					UOC:A14,A26,A27,B18,H14,H18,H26,H27,H28	
9	PAFZZ	5310000806004	96906	MS27183-14	WASHER,FLAT 3/8, USBL EFF 100,000 AND ABOVE.....	8
					UOC:A14,A26,A27,B18,H14,H18,H26,H27,H28	
10	PAFZZ	5310009359021	96906	MS51943-35	NUT,SELF-LOCKING,HE 3/8-16, USBL EFF 100,000 AND ABOVE.....	4
					UOC:A14,A26,A27,B18,H14,H18,H26,H27,H28	
11	PAOZZ	5310004883889	96906	MS51943-39	NUT,SELF-LOCKING,HE 1/2-13, USBL EFF 100,000 AND ABOVE.....	10
					UOC:A14,A26,A27,B18,H14,H18,H26,H27,H28	

SECTION II			TM9-2320-280-24P			
(1)	(2)	(3)	(4)	(5)	(6)	(7)
ITEM	SMR			PART		
NO	CODE	NSN	CAGEC	NUMBER	DESCRIPTION AND USABLE ON CODES(UOC)	QTY
12	PAOZZ	5310011211703	24617	2436165	H28 WASHER,FLAT 1/2, USBL EFF 100,000 AND ABOVE..... UOC:A14,A26,A27,B18,H13,H18,H26,H27, H28	18
12	PAOZZ	5310012538948	34623	5593320	WASHER,FLAT 1/2, USBL EFF 1 THRU 99,999..... UOC:H14,H18,H26,H27,H28	16
13	PAOZZ	2590013160084	34623	12342404	BRACKET,VEHICULAR C..... UOC:A14,A26,A27,B18,H14,H18,H26,H27, H28	2
14	PAOZZ	5305000712069	80204	B1821BH050C150N	SCREW,CAP,HEXAGON H 1/2-13 X 1.50, USBL EFF 100,000 AND ABOVE..... UOC:A14,A26,A27,B18,H14,H18,H26,H27, H28	10
15	PAOZZ	5305012643602	19207	12338225-1	SCREW,CAP,HEXAGON H 5/8-18 X 5.50.. UOC:A14,A26,A27,B18,H14,H18,H26,H27, H28	2
16	PAOZZ	4030013161551	19207	12342354	SHACKLE..... UOC:A14,A26,A27,B18,H14,H18,H26,H27, H28	2
17	PAOZZ	5310005957486	77820	10-40704-22	WASHER,SPRING,TENSI 49/64 I.D..... UOC:A14,A26,A27,B18,H14,H18,H26,H27, H28	2
18	PAOZZ	5310008507004	96906	MS35692-54	NUT,PLAIN,SLOTTED,H 5/8-18..... UOC:A14,A26,A27,B18,H14,H18,H26,H27, H28	2
19	PAOZZ	5315000120123	96906	MS24665-355	PIN,COTTER 1/8 X 1.25..... UOC:A14,A26,A27,B18,H14,H18,H26,H27, H28	2

END OF FIGURE

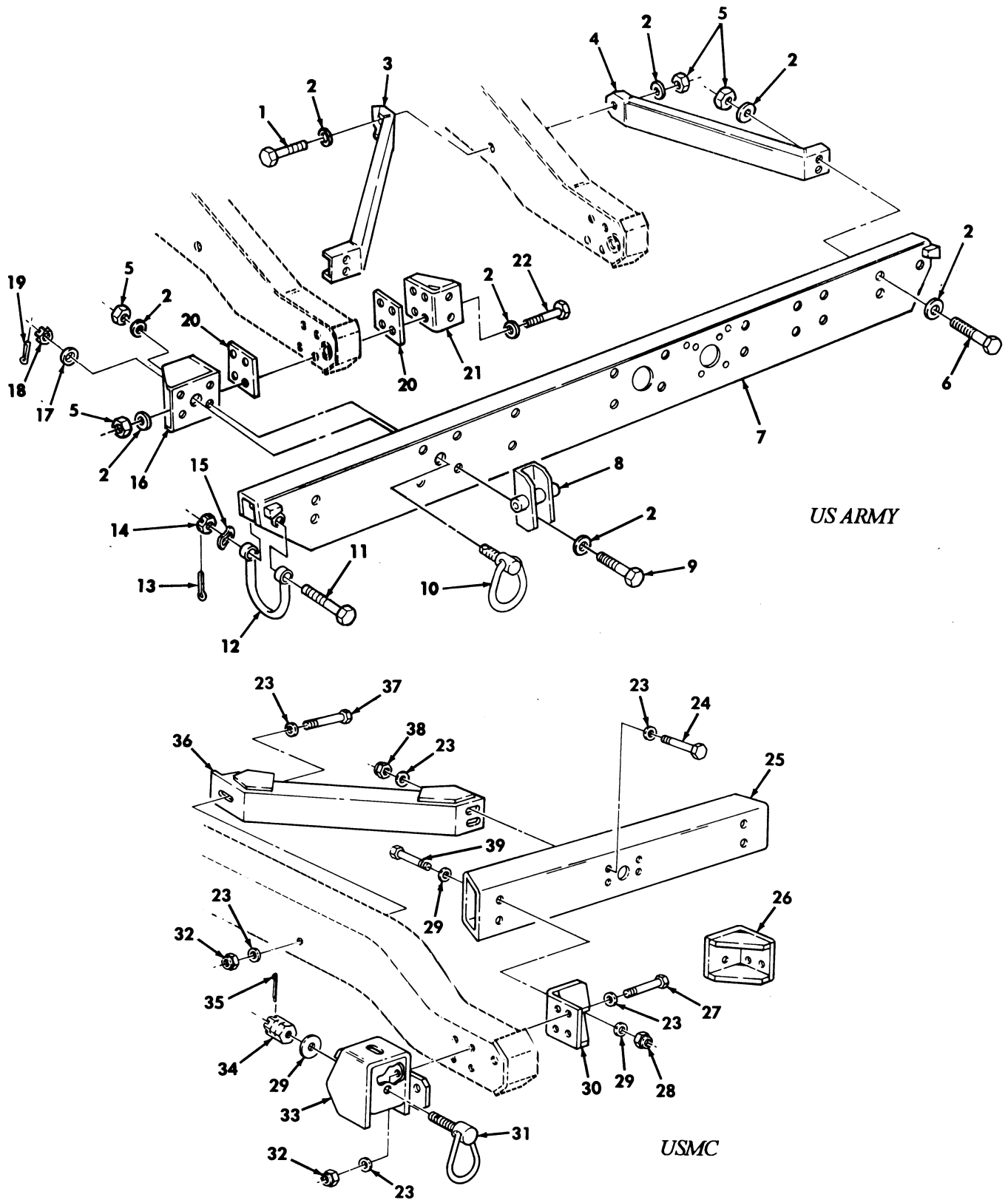

Figure 188. Rear Bumper and Lifting Shackle.

SECTION II			TM9-2320-280-24P			
(1)	(2)	(3)	(4)	(5)	(6)	(7)
ITEM	SMR			PART		
NO	CODE	NSN	CAGEC	NUMBER	DESCRIPTION AND USABLE ON CODES(UOC)	QTY
GROUP 1501 FRAME ASSEMBLY						
FIG. 188 REAR BUMPER AND LIFTING SHACKLE						
1	PAOZZ	5305000712078	80204	B1821BH050C375N	SCREW,CAP,HEXAGON H 1/2-13 X 3.75..	2
					UOC:AVY,A15,BVY,B15,B16,B20,B24,B25,C17,HVY,H15,H16,H21,H28,NNN	
2	PAOZZ	5310012538948	34623	5593320	WASHER,FLAT 1/2.....	52
					UOC:AVY,A15,BVY,B15,B16,B20,B24,B25,C17,HVY,H15,H16,H21,H28,NNN	
3	PAOZZ	2540012573877	19207	12339186	BRACE ASSEMBLY,BUMP INNER.....	2
					UOC:AVY,A15,BVY,B15,B16,B20,B24,B25,C17,HVY,H15,H16,H21,H28,NNN	
4	PFOZZ	5340011964720	19207	12340019	BRACKET,MOUNTING OUTER.....	2
					UOC:AVY,A15,BVY,B15,B16,B20,B24,B25,C17,HVY,H15,H16,H21,H28,NNN	
5	PAOZZ	5310004883889	96906	MS51943-39	NUT,SELF-LOCKING,HE 1/2-13.....	26
					UOC:AVY,A15,BVY,B15,B16,B20,B24,B25,C17,HVY,H15,H16,H21,H28,NNN	
6	PAOZZ	5305000712075	80204	B1821BH050C300N	SCREW,CAP,HEXAGON H 1/2-13 X 3.00..	12
					UOC:AVY,A15,BVY,B15,B16,B20,B24,B25,C17,HVY,H15,H16,H21,H28,NNN	
7	PAOZZ	2540011964920	19207	12338218	BUMPER,VEHICULAR.....	1
					UOC:AVY,A15,B16,HVY,H15,H16,H21,H28	
7	PAOZZ	2540014112733	19207	12446973	BUMPER,VEHICULAR.....	1
					UOC:BVY,B15,B20,B24,B25,C17,NNN	
8	PAOZZ	2590013159128	34623	12342373	BRACKET,VEHICULAR C.....	2
					UOC:AVY,A15,B16,HVY,H15,H16,H21,H28	
9	PAOZZ	5305000712076	80204	B1821BH050C325N	SCREW,CAP,HEXAGON H 1/2-13 X 3.25..	4
					UOC:AVY,A15,B16,HVY,H15,H16,H21,H28	
10	PAOZZ	5340014127514	19207	12447089-2	CONNECTOR,ROD END.....	2
					UOC:BVY,B15,B20,B24,B25,C17,NNN	
11	PAOZZ	5305012643602	19207	12338225-1	SCREW,CAP,HEXAGON H 5/8-18 X 5.50..	2
					UOC:AVY,A15,BVY,B15,B16,HVY,H15,H16,H21,H28,NNN	
12	PAOZZ	4030013161551	19207	12342354	SHACKLE.....	2
					UOC:AVY,A15,BVY,B15,B16,HVY,H15,H16,H21,H28,NNN	
13	PAOZZ	5315000120123	80205	MS24665-355	PIN,COTTER 1/8 X 1.25.....	2
					UOC:AVY,A15,BVY,B15,B16,HVY,H15,H16,H21,H28,NNN	
14	PAOZZ	5310008507004	96906	MS35692-54	NUT,PLAIN,SLOTTED,H 5/8-18.....	2
					UOC:AVY,A15,BVY,B15,B16,HVY,H15,H16,H21,H28,NNN	
15	PAOZZ	5310005957486	77820	10-40704-22	WASHER,SPRING TENSI 49/64 I.D.....	2
					UOC:AVY,A15,BVY,B15,B16,HVY,H15,H16,H21,H28,NNN	
16	PFOZZ	5340014088523	19207	12446989	BRACKET,MOUNTING OUTER,L.H.....	1
					UOC:BVY,B15,B20,B24,B25,C17,NNN	
16	PFOZZ	5340014088529	19207	12446990	BRACKET,MOUNTING OUTER,R.H.....	1
					UOC:BVY,B15,B20,B24,B25,C17,NNN	
16	PFOZZ	2540011964721	34623	5589028	SUPPORT,BUMPER OUTER, L.H.....	1

SECTION II			TM9-2320-280-24P			
(1)	(2)	(3)	(4)	(5)	(6)	(7)
ITEM	SMR			PART		
NO	CODE	NSN	CAGEC	NUMBER	DESCRIPTION AND USABLE ON CODES(UOC)	QTY
16	PFOZZ	2540011964722	34623	5589033	UOC:AVY,A15,B16,HVY,H15,H16,H21,H28 SUPPORT,BUMPER OUTER, R.H.....	1
17	PAOZZ	5310011474052	24617	2436168	UOC:AVY,A15,B16,HVY,H15,H16,H21,H28 WASHER,FLAT 3/4.....	2
18	PAOZZ		24617	9429395	UOC:BVY,B15,B20,B24,B25,C17,NNN NUT,PLAIN,CASTELLAT 3/4-20.....	2
19	PAOZZ	5315002398032	80205	MS24665-513	UOC:BVY,B15,B20,B24,B25,C17,NNN PIN,COTTER 3/32 X 1/2.....	2
20	PFOZZ	5340012055377	19207	12338164	UOC:BVY,B15,B20,B24,B25,C17,NNN SPACER,PLATE.....	4
21	PFOZZ	5340014766243	19207	12446991	UOC:AVY,A15,BVY,B15,B16,HVY,H15,H16, H21,H28,NNN BRACKET,MOUNTING INNER.....	2
21	PFOZZ	2540011964723	19207	12338194	UOC:BVY,B15,B20,B24,B25,C17,NNN SUPPORT,BUMPER INNER.....	2
22	PAOZZ	5305000711783	80204	B1821BH050C425N	UOC:AVY,A15,B16,HVY,H15,H16,H21,H28 SCREW,CAP,HEXAGON H 1/2-13 X 4.25..	8
23	PAOZZ	5310011211703	11862	2436165	UOC:AVY,A15,BVY,B15,B16,B20,B24,B25, C17,HVY,H15,H16,H21,H28,NNN WASHER,FLAT.....	24
24	PAOZZ	5305000712073	80204	B1821BH050C250N	UOC:NNN SCREW,CAP,HEXAGON H.....	4
25	PAOZZ	2540014766609	34623	RCSK18530	UOC:NNN PINTLE CHANNEL.....	1
26	PAOZZ	5340014762963	34623	RCSK18531	UOC:NNN BRACKET,MOUNTING R.H.....	1
27	PAOZZ	5306011865369	7X677	9415560	UOC:NNN BOLT,MACHINE.....	8
28	PAOZZ		24617	9419507	UOC:NNN NUT,PLAIN,HEXAGON.....	4
29	PAOZZ	5310011474052	24617	2436168	UOC:NNN WASHER,FLAT.....	10
30	PAOZZ	5340014765072	34623	RCSK18596	UOC:NNN BRACKET,MOUNTING L.H.....	1
31	PAOZZ	5340014130282	19207	12447089-1	UOC:NNN CONNECTOR,ROD END.....	2
32	PAOZZ	5310002256993	77445	PWA10132-3	UOC:NNN NUT,SELF-LOCKING,HE.....	10
33	PAOZZ	5340014762840	34623	RCSK18747-2	UOC:NNN BRACKET,MOUNTING.....	1
33	PAOZZ	5340014762845	34623	RCSK18747-1	UOC:NNN BRACKET,MOUNTING.....	1
34	PAOZZ		24617	9429395	UOC:NNN NUT,PLAIN,CASTELLAT.....	2
35	PAOZZ	5315002398032	80205	MS24665-513	UOC:NNN PIN,COTTER.....	2
36	PAOZZ	5340014762972	34623	RCSK18532	UOC:NNN BRACKET,MOUNTING.....	2
37	PAOZZ	5306013601128	24617	455006	UOC:NNN BOLT,MACHINE.....	2
38	PAOZZ	5310004883889	96906	MS51943-39	UOC:NNN NUT,SELF-LOCKING,HE.....	4



SECTION II			TM9-2320-280-24P			
(1)	(2)	(3)	(4)	(5)	(6)	(7)
ITEM	SMR			PART		
NO	CODE	NSN	CAGEC	NUMBER	DESCRIPTION AND USABLE ON CODES (UOC)	QTY
39	PAOZZ		24617	223533	BOLT, MACHINE.....	4
					UOC:NNN	

END OF FIGURE

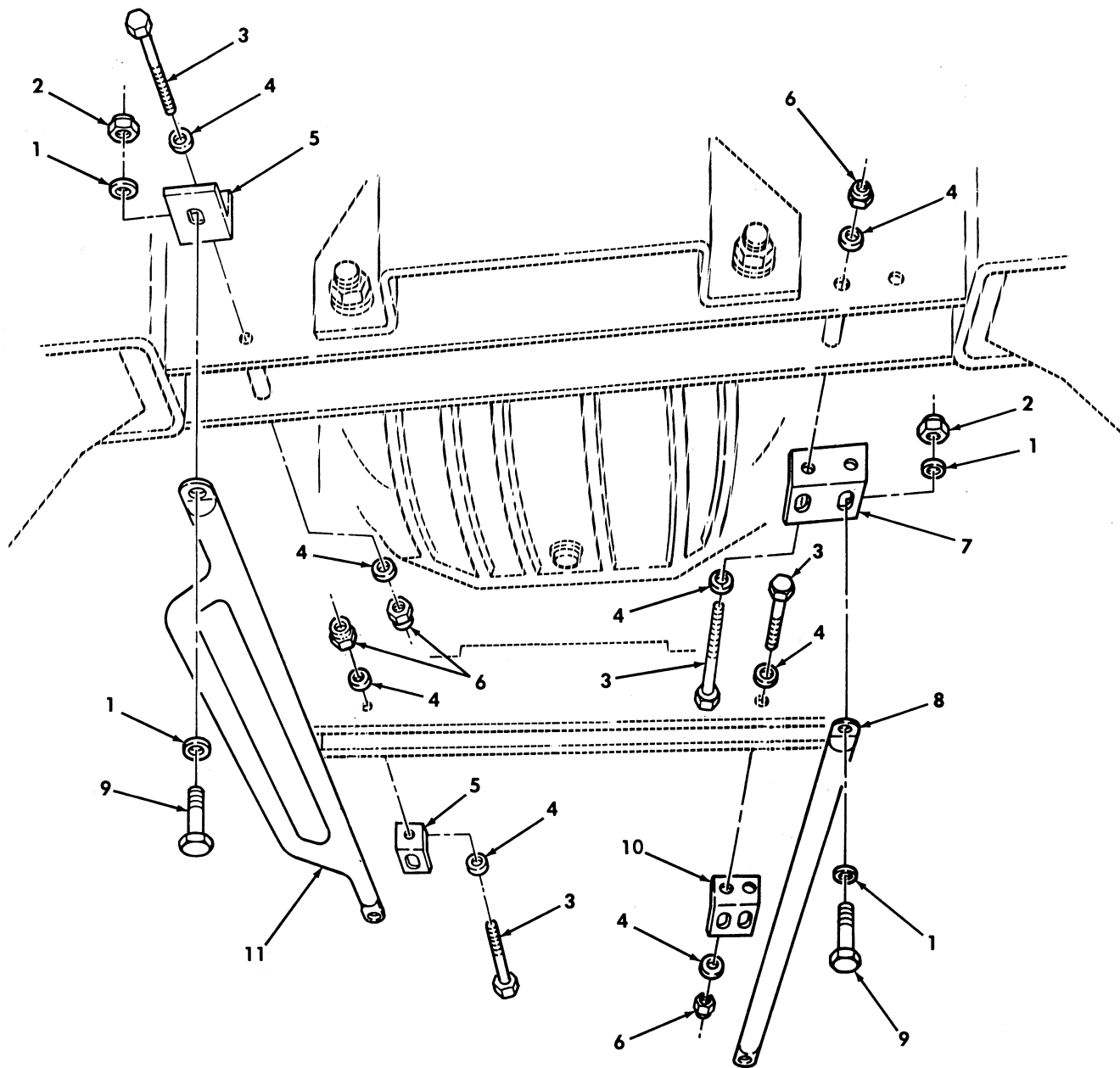

Figure 189. Brake Protection Guard (Front).

SECTION II			TM9-2320-280-24P			
(1)	(2)	(3)	(4)	(5)	(6)	(7)
ITEM NO	SMR CODE	NSN	CAGEC	PART NUMBER	DESCRIPTION AND USABLE ON CODES(UOC)	QTY
GROUP 1501 FRAME ASSEMBLY						
FIG. 189 BRAKE PROTECTION GUARD (FRONT)						
1	PAOZZ	5310000806004	96906	MS27183-14	WASHER,FLAT 3/8.....	12
					UOC:BVY,B15,B20,B24,B25,C17,NNN	
2	PAOZZ	5310009359021	96906	MS51943-35	NUT,SELF-LOCKING,HE 3/8-16.....	6
					UOC:BVY,B15,B20,B24,B25,C17,NNN	
3	PAOZZ	5306002264838	80204	B1821BH031C325N	BOLT,MACHINE 5/16-18 X 3.25.....	6
					UOC:BVY,B15,B20,B24,B25,C17,NNN	
4	PAOZZ	5310000814219	96906	MS27183-12	WASHER,FLAT 5/16.....	12
					UOC:BVY,B15,B20,B24,B25,C17,NNN	
5	PAOZZ	5340014324870	34623	6002345	BRACKET,ANGLE L.H. FRONT AND REAR..	2
					UOC:BVY,B15,B20,B24,B25,C17,NNN	
6	PAOZZ	5310008140673	96906	MS51943-33	NUT,SELF-LOCKING,HE 5/16-18.....	6
					UOC:BVY,B15,B20,B24,B25,C17,NNN	
7	PAOZZ	5340014342832	34623	6002344	BRACKET,ANGLE R.H. FRONT.....	1
					UOC:BVY,B15,B20,B24,B25,C17,NNN	
8	PAOZZ	2540014329894	34623	6002347	GUARD,BRUSH,VEHICUL R.H. FRONT.....	2
					UOC:BVY,B15,B20,B24,B25,C17,NNN	
9	PAOZZ	5305000680511	80204	B1821BH038C125N	SCREW,CAP,HEXAGON H 3/8-16 X 1.25..	6
					UOC:BVY,B15,B20,B24,B25,C17,NNN	
10	PAOZZ	5340014384497	34623	6002343	BRACKET,MULTIPLE R.H. FRONT.....	1
					UOC:BVY,B15,B20,B24,B25,C17,NNN	
11	PAOZZ	2540014329899	34623	6002348	GUARD,BRUSH,VEHICUL L.H. FRONT.....	1
					UOC:BVY,B15,B20,B24,B25,C17,NNN	

END OF FIGURE

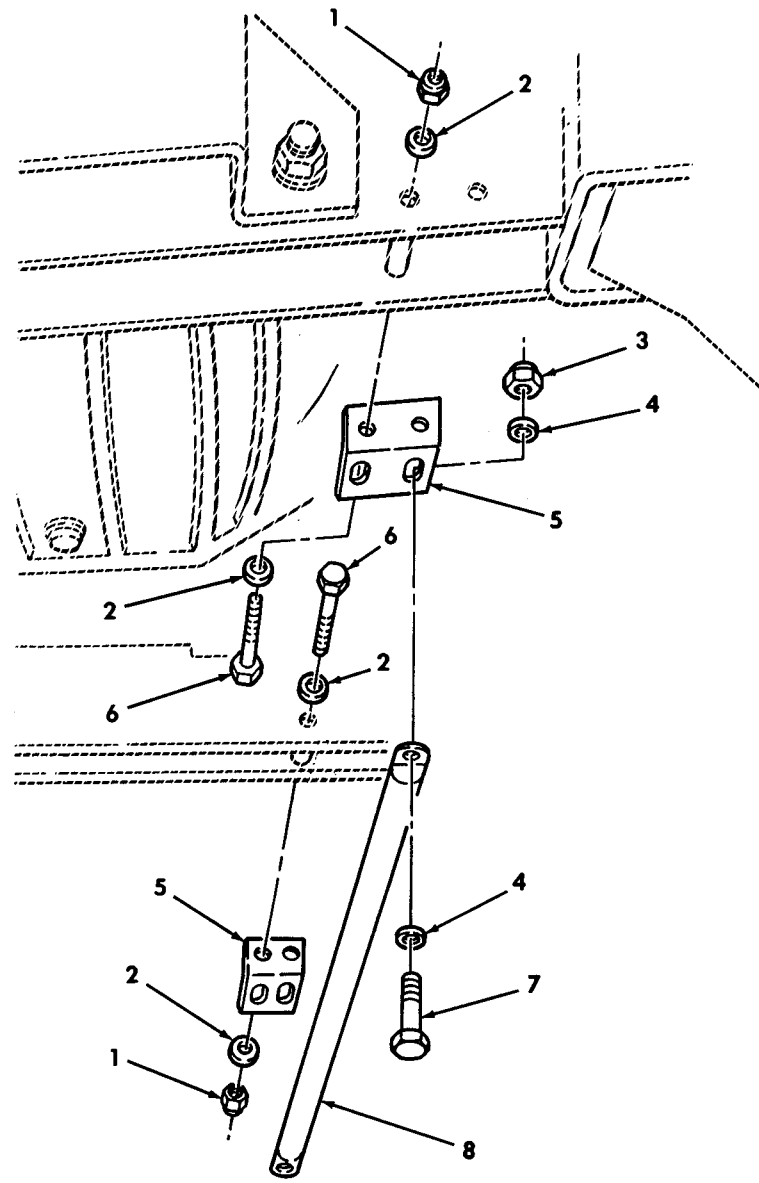

Figure 190. Brake Protection Guard (Rear).

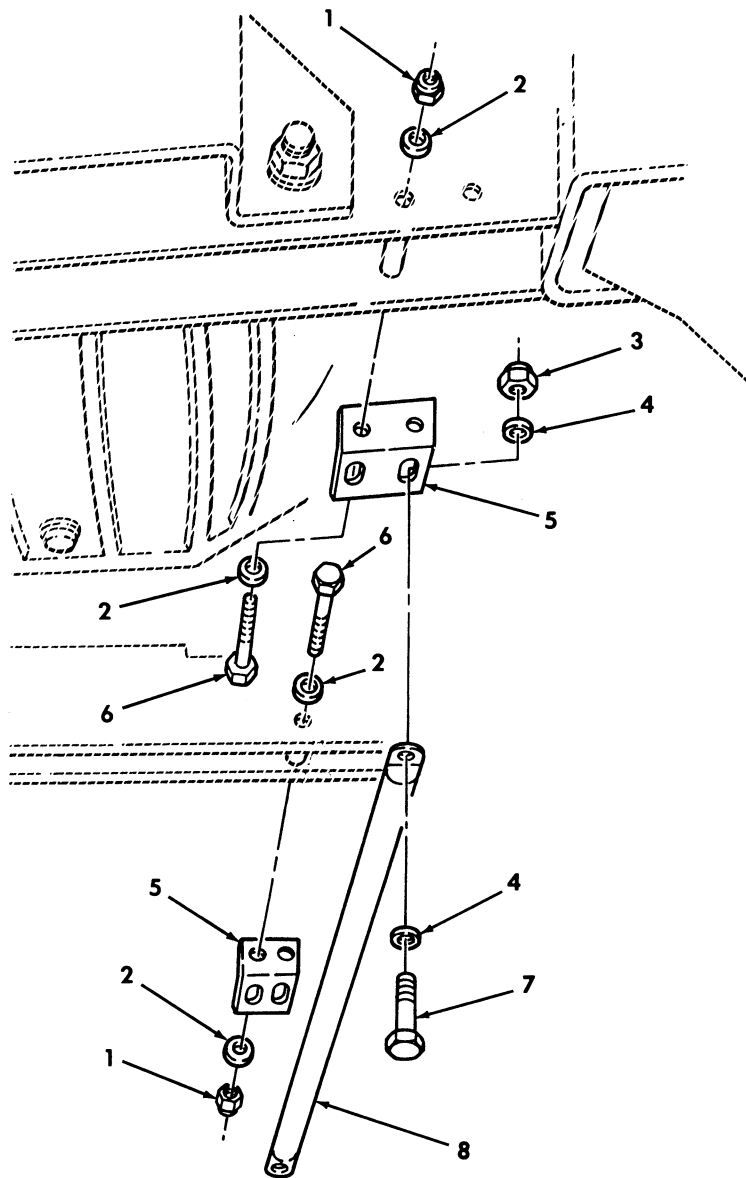

Figure 190. Brake Protection Guard (Rear).

SECTION II			TM9-2320-280-24P			
(1)	(2)	(3)	(4)	(5)	(6)	(7)
ITEM	SMR			PART		
NO	CODE	NSN	CAGEC	NUMBER	DESCRIPTION AND USABLE ON CODES(UOC)	QTY
GROUP 1501 FRAME ASSEMBLY						
FIG. 190 BRAKE PROTECTION GUARD (REAR)						
1	PAOZZ	5310008140673	96906	MS51943-33	NUT,SELF-LOCKING,HE 5/16-18.....	8
					UOC:BVY,B15,B20,B24,B25,C17,NNN	
2	PAOZZ	5310000814219	96906	MS27183-12	WASHER,FLAT 5/16.....	16
					UOC:BVY,B15,B20,B24,B25,C17,NNN	
3	PAOZZ	5310009359021	96906	MS51943-35	NUT,SELF-LOCKING,HE 3/8-16.....	8
					UOC:BVY,B15,B20,B24,B25,C17,NNN	
4	PAOZZ	5310000806004	96906	MS27183-14	WASHER,FLAT 3/8.....	16
					UOC:BVY,B15,B20,B24,B25,C17,NNN	
5	PAOZZ	5340014332721	34623	6002346	BRACKET,ANGLE REAR.....	4
					UOC:BVY,B15,B20,B24,B25,C17,NNN	
6	PAOZZ	5305014599564	24617	453039	SCREW,CAP,HEXAGON H 5/16-18 X 2.75..	8
					UOC:BVY,B15,B20,B24,B25,C17,NNN	
7	PAOZZ	5305000680511	80204	B1821BH038C125N	SCREW,CAP,HEXAGON H 3/8-16 X 1.25..	8
					UOC:BVY,B15,B20,B24,B25,C17,NNN	
8	PAOZZ	2540014329894	34623	6002347	GUARD,BRUSH,VEHICUL.....	4
					UOC:BVY,B15,B20,B24,B25,C17,NNN	

END OF FIGURE

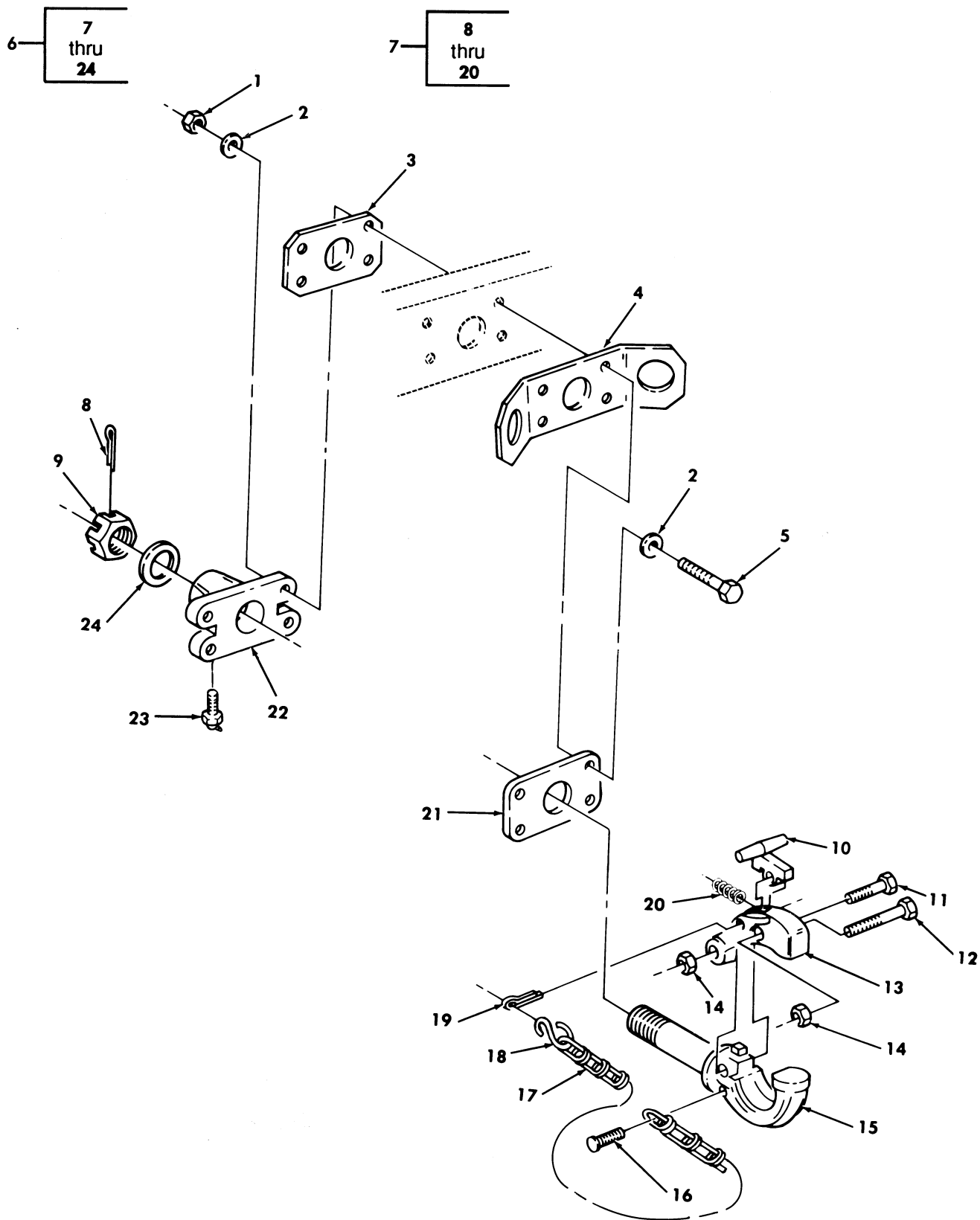

Figure 191. Towing Pintle Assembly.

SECTION II			TM9-2320-280-24P			
(1)	(2)	(3)	(4)	(5)	(6)	(7)
ITEM	SMR			PART		
NO	CODE	NSN	CAGEC	NUMBER	DESCRIPTION AND USABLE ON CODES(UC)	QTY
GROUP 1503 PINTLES AND TOWING ATTACHMENTS						
FIG. 191 TOWING PINTLE ASSEMBLY						
1	PAOZZ	5310004883889	96906	MS51943-39	NUT, SELF-LOCKING, HE 1/2-13.....	4
2	PAOZZ	5310012538948	34623	5593320	WASHER, FLAT 1/2.....	8
3	PFOZZ	5365012193528	19207	12338195	SPACER, PLATE.....	1
4	PFOZZ	2540011866039	19207	12338189	PLATE, MOUNTING, GROM.....	1
5	PAOZZ	5305000712073	80204	B1821BH050C250N	SCREW, CAP, HEXAGON H 1/2-13 X 2.50..	4
6	PFOO	2540011892193	20669	B-6	PINTLE ASSEMBLY, TOW.....	1
7	PAOZZ	2540000786633	96906	MS51335-1	.PINTLE ASSEMBLY, TOW.....	1
8	PAOZZ	5315008460126	96906	MS24665-628	..PIN, COTTER 1/4 X 3.00.....	1
9	PAOZZ	5310008496882	96906	MS35692-94	..NUT, PLAIN, SLOTTED, H 1.25-12.....	1
10	PFOZZ	2540010235116	19207	8380196	..LATCH, PINTLE HOOK.....	1
11	PAOZZ	5305012711806	19207	12296696-2	..SCREW, CAP, HEXAGON H 1/2-20 X 1.75	1
12	PAOZZ	5305007195240	39428	91248A721	..SCREW, CAP, HEXAGON H 1/2-20 X 2.50	1
13	PFOZZ	2540005257067	19207	7524314	..LATCH, PINTLE HOOK.....	1
14	PAOZZ	5310004492376	96906	MS21245-8	..NUT, SELF-LOCKING, HE 1/2-20.....	2
15	PAOZZ	2540000786633	96906	MS51335-1	..PINTLE ASSEMBLY, TOW TOWING.....	1
16	PFOZZ	5305002535626	80205	MS21318-47	..SCREW, DRIVE #10-8 X 1/2.....	1
17	MOOZZ		81348	RR-C-271-6	..CHAIN MAKE FROM CHAIN, P/N C43974, 6 LINKS.....	1
18	PAOZZ	4030009162141	96906	MS87006-53	..HOOK, CHAIN, S.....	1
19	PAOZZ	5315002431169	80020	36344N24	..PIN, COTTER 1/4 X 2.00.....	1
20	PAOZZ	5360007044253	19207	7044253	..SPRING, HELICAL, COMP.....	1
21	PFOZZ	3040001275322	19207	7355393	..PLATE, RETAINING, SHA.....	1
22	PFOZZ	5340004082432	19207	7355392	..BRACKET, MOUNTING.....	1
23	PAOZZ	4730000504207	96906	MS15001-4	..FITTING, LUBRICATION.....	1
24	PAOZZ	5310007355396	19207	7355396	..WASHER, FLAT 1.25.....	1

END OF FIGURE



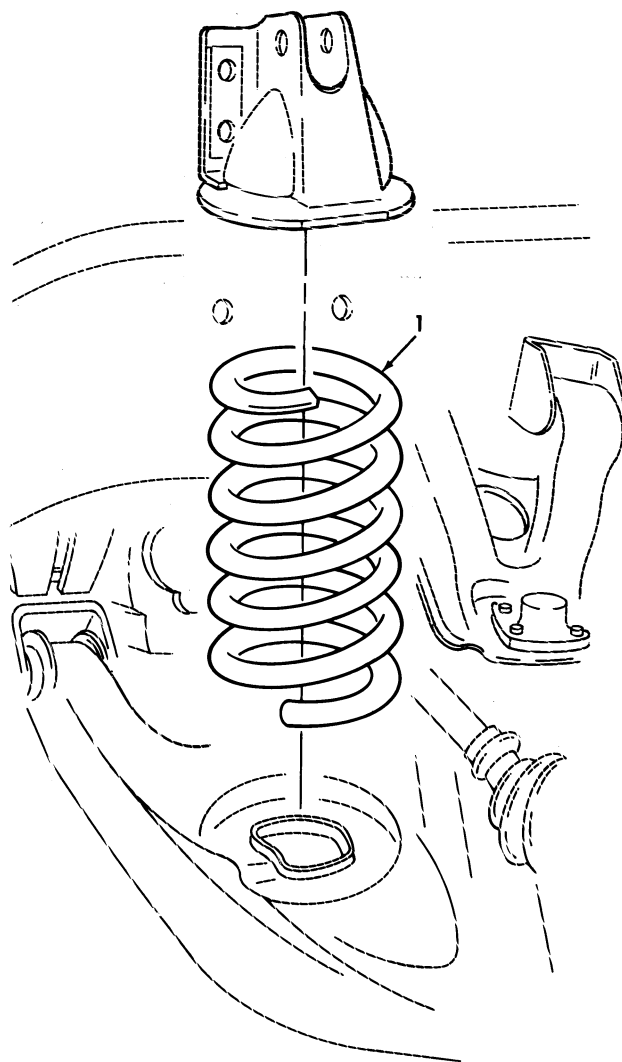

Figure 192. Springs, Front and Rear.

SECTION II			TM9-2320-280-24P			
(1)	(2)	(3)	(4)	(5)	(6)	(7)
ITEM	SMR			PART		
NO	CODE	NSN	CAGEC	NUMBER	DESCRIPTION AND USABLE ON CODES(UC)	QTY
					GROUP 16 SPRINGS AND SHOCK ABSORBERS	
					1601 SPRINGS	
					FIG. 192 SPRINGS,FRONT AND REAR	
1	PAOZZ	5360013572413	19207	12342616	SPRING,HELICAL,COMP REAR.....	2
					UOC:AVY,A11,A13,A14,A15,A20,A24,A25,	
					A26,A27,BVY,B15,B16,B17,B18,B20,B24,	
					B25,C17,HVY,NNN	
1	PAOZZ	5360012541492	34623	12338316-3	SPRING,HELICAL,COMP REAR.....	2
					UOC:H15,H16,H21,H28	
1	PAOZZ	5360011794106	34623	12338316-2	SPRING,HELICAL,COMP REAR.....	2
					UOC:H11,H13,H14,H17,H18,H20,H24,H25,	
					H26,H27,MMM	
1	PAOZZ	5360011794107	19207	12338316-1	SPRING,HELICAL,COMP FRONT.....	2

END OF FIGURE

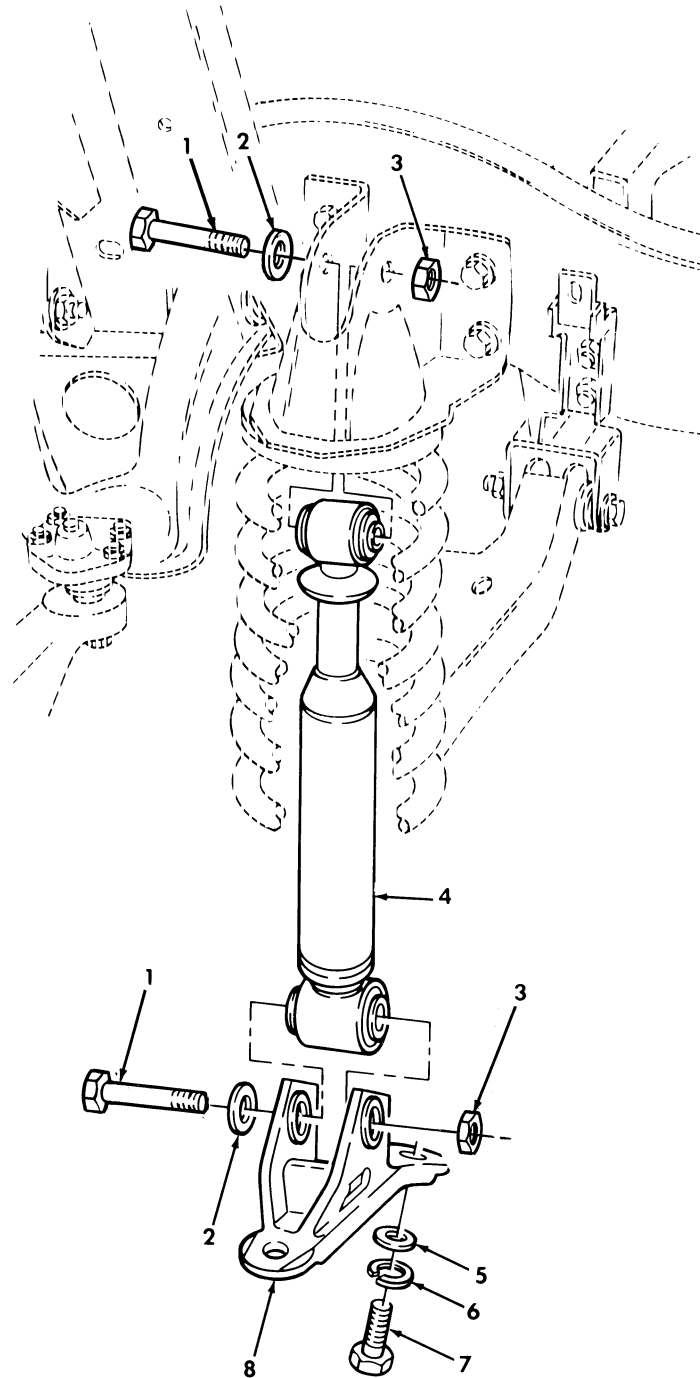

Figure 193. Shock Absorbers, Front and Rear.

SECTION II			TM9-2320-280-24P			
(1)	(2)	(3)	(4)	(5)	(6)	(7)
ITEM NO	SMR CODE	NSN	CAGEC	PART NUMBER	DESCRIPTION AND USABLE ON CODES(UC)	QTY
GROUP 1604 SHOCK ABSORBER EQUIPMENT						
FIG. 193 SHOCK ABSORBERS,FRONT AND REAR						
1	PAOZZ	5365011867764	34623	5595454	BUSHING,MACHINE THR FRONT AND REAR, 1.00-14 X 3.17.....	8
2	PAOZZ	5310011873485	7X677	2065616	WASHER,FLAT 1.00.....	8
3	PAOZZ	5310014391154	34623	12339206	NUT,SELF-LOCKING,HE 1.00-14.....	8
4	PAOZZ	2510011903862	76445	70113	SHOCK ABSORBER,DIRE FRONT SUSPENSION.....	2
4	PAOZZ	2510012515316	76445	70114	SHOCK ABSORBER,DIRE REAR H.D..... UOC:AVY,A11,A13,A14,A15,A20,A24,A25, A26,A27,BVY,B15,B16,B17,B18,B20,B24, B25,C17,HVY,H15,H16,H21,H28,NNN	2
4	PAOZZ	2510011891832	76445	70112	SHOCK ABSORBER,DIRE REAR..... UOC:H11,H13,H14,H17,H18,H20,H24,H25, H26,H27,MMM	2
5	PAOZZ	5310008238803	96906	MS27183-21	WASHER,FLAT 5/8.....	8
6	PAOZZ	5310008206653	96906	MS35338-50	WASHER,LOCK 5/8.....	8
7	PAOZZ	5306012552661	7X677	9424760	BOLT,MACHINE 5/8-11 X 2.00.....	8
8	PAOZZ	2510011877037	19207	12338315	BRACKET,SHOCK MOUNT.....	4

END OF FIGURE

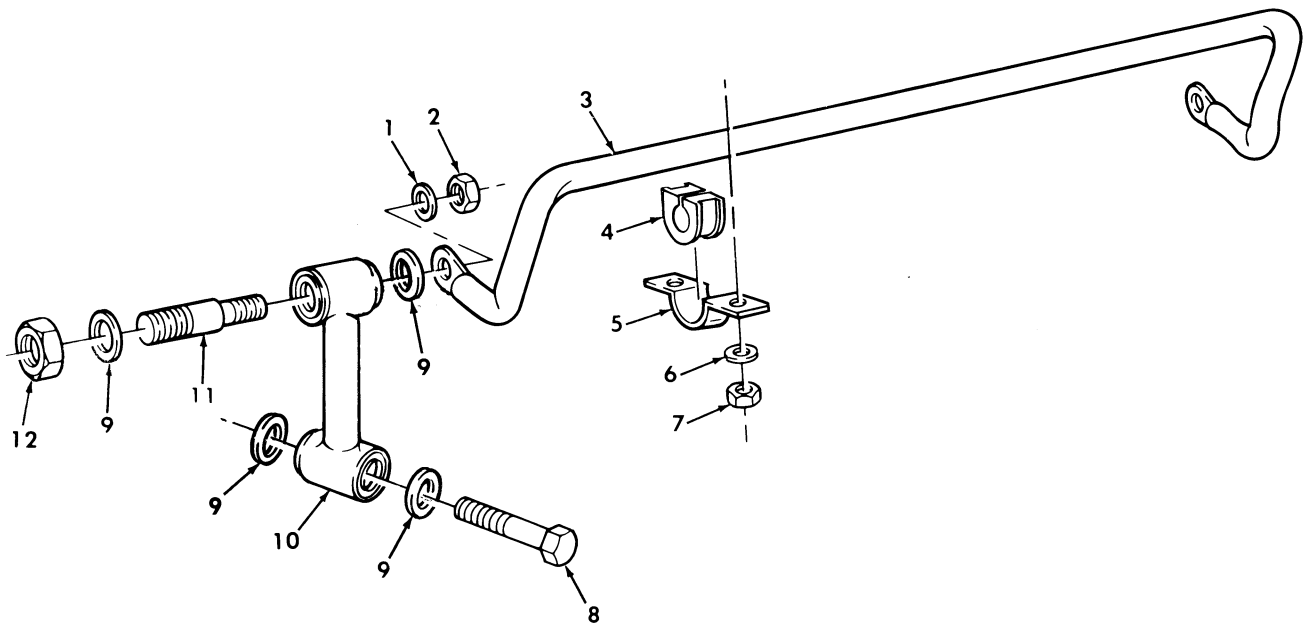
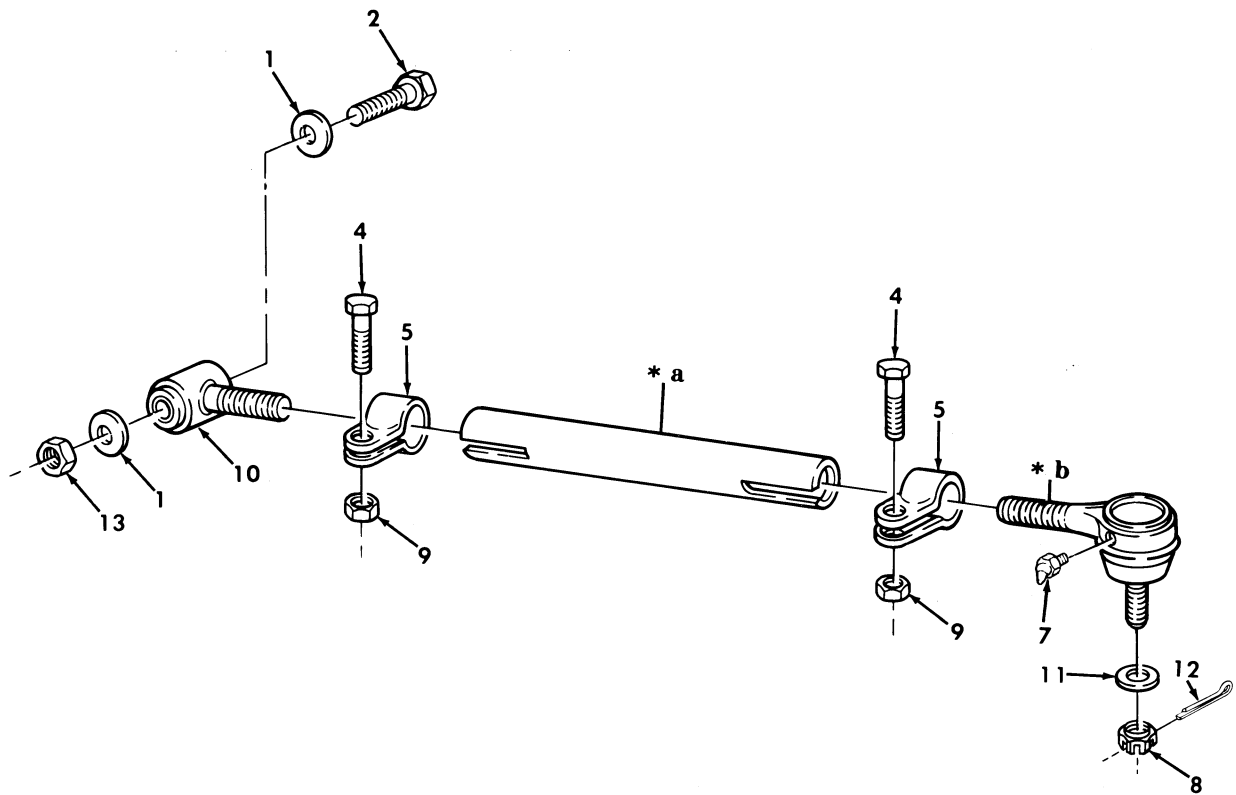
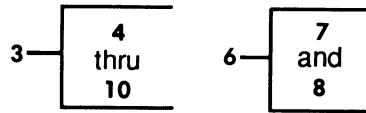

Figure 194. Stabilizer Bar and Connecting Links.

SECTION II			TM9-2320-280-24P			
(1)	(2)	(3)	(4)	(5)	(6)	(7)
ITEM NO	SMR CODE	NSN	CAGEC	PART NUMBER	DESCRIPTION AND USABLE ON CODES(UOC)	QTY
					GROUP 1605 TORQUE,RADIUS AND STABILIZER RODS	
					FIG. 194 STABILIZER BAR AND CONNECTING LINKS	
1	PAOZZ	5310012538948	34623	5593320	WASHER,FLAT 1/2.....	2
2	PAOZZ	5310011845784	7X677	9422302	NUT,PLAIN,HEXAGON 1/2-20.....	2
3	PAOZZ	2510011872239	19207	12338329	BAR,STABILIZER.....	1
					UOC:AVY,A11,A13,A14,A15,A20,A24,A25,A26,A27,B16,B17,B18,HVY,H11,H13,H14,H15,H16,H17,H18,H20,H21,H24,H25,H26,H27,H28,MMM	
3	PAOZZ	2510014562277	34623	6004872	BAR,STABILIZER.....	1
					UOC:BVY,B15,B20,B24,B25,C17,NNN	
4	PAOZZ	5325011910595	19207	12338317	GROMMET,NONMETALLIC STABILIZER BAR.	2
5	PAOZZ	5340011900810	19207	12338319	STRAP,RETAINING.....	2
6	PAOZZ	5310001670822	19207	7725882	WASHER,FLAT 7/16.....	4
7	PAOZZ	5310008960903	96906	MS51967-12	NUT,PLAIN,HEXAGON 7/16-14.....	4
8	PAOZZ	5305007247228	80204	B1821BH063C300N	SCREW,CAP,HEXAGON H 5/8-11 X 3.00..	2
9	PAOZZ	5310011858689	19207	12338322	WASHER,FLAT 5/8.....	8
10	PAOZZ	3040011863718	34623	12338323	CONNECTING LINK,RIG.....	2
11	PAOZZ	5307011881229	19207	12339207	STUD,RECESSED AND S.....	2
12	PAOZZ	5310000614651	19207	12387349-43	NUT,SELF-LOCKING,HE 5/8-11.....	2

END OF FIGURE



- \* a PART OF ITEM 3
- \* b PART OF ITEM 6

Figure 195. Rear Radius Rods.

SECTION II			TM9-2320-280-24P			
(1)	(2)	(3)	(4)	(5)	(6)	(7)
ITEM NO	SMR CODE	NSN	CAGEC	PART NUMBER	DESCRIPTION AND USABLE ON CODES(UOC)	QTY
					GROUP 1605 TORQUE,RADIUS AND STABILIZER RODS	
					FIG. 195 REAR RADIUS RODS	
1	PAOZZ	5310012604839	34623	5593312	WASHER,FLAT 3/4.....	4
2	PAOZZ	5305009474361	80204	B1821BH075C475N	SCREW,CAP,HEXAGON H 3/4-10 X 4.75..	2
3	PAOZZ	2510012056089	98349	L-18-VT-5277-B-1	BAR,STABILIZER REAR.....	2
				1		
4	PAOZZ	5305012117478	7X677	9419079	.SCREW,CAP,HEXAGON H 7/16-14 X 1-3/4	2
5	PAOZZ	5340011918161	98349	L-18-CPS-5-A-10	.CLAMP,LOOP.....	2
6	PAOZZ	2530011972160	98349	L-18-SV-5150-C-1	.TIE ROD END,STEERIN L.H.....	1
				2		
7	PAOZZ	4730000504205	96906	MS15001-3	..FITTING,LUBRICATION.....	1
8	PAOZZ	5310008507004	96906	MS35692-54	..NUT,PLAIN,SLOTTED,H 5/18-18.....	1
9	PAOZZ	5310008960903	96906	MS51967-12	.NUT,PLAIN,HEXAGON 7/16-14.....	2
10	PAOZZ	2530011863740	27387	941180	.TIE ROD END,STEERIN.....	1
11	PAOZZ	5310011517347	24617	2436167	WASHER,FLAT 5/8.....	2
12	PAOZZ	5315000120123	80205	MS24665-355	PIN,COTTER 1/8 X 1.25.....	2
13	PAOZZ	5310004093333	96906	MS51943-45	NUT,SELF-LOCKING,HE 3/4-10.....	2

END OF FIGURE



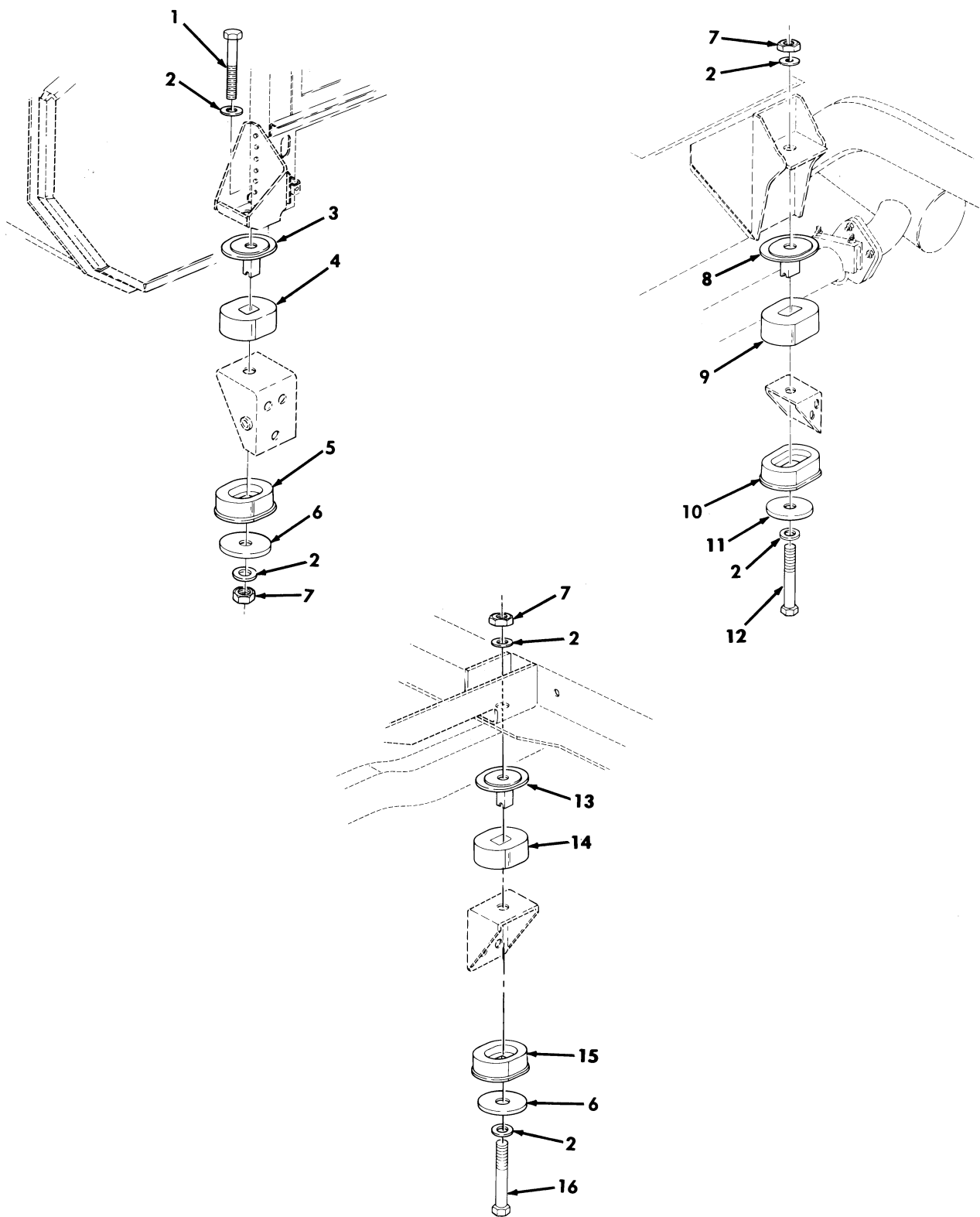

Figure 196. Body Mounting Components.

SECTION II			TM9-2320-280-24P			
(1)	(2)	(3)	(4)	(5)	(6)	(7)
ITEM NO	SMR CODE	NSN	CAGEC	PART NUMBER	DESCRIPTION AND USABLE ON CODES(UOC)	QTY
					GROUP 18 BODY,CAB,HOOD,AND HULL ASSEMBLY	
					1801 BODY,CAB,HOOD,AND HULL ASSEMBLY	
					FIG. 196 BODY MOUNTING COMPONENTS	
1	PAHZZ	5305007247254	80204	B1821BH063C400N	SCREW,CAP,HEXAGON H FRONT R.H.,5/8-11 X 4.00.....	1
1	PAHZZ	5305007247248	80204	B1821BH063C375N	SCREW,CAP,HEXAGON H FRONT L.H.,5/8-11 X 3.75.....	1
2	PAHZZ	5310011517347	24617	2436167	WASHER,FLAT 5/8.....	12
3	PAHZZ	5365011861294	34623	5569268	SPACER,SLEEVE FRONT.....	2
4	PAHZZ	5342011895452	34623	5569270	MOUNT,RESILIENT UPPER FRONT.....	2
5	PAHZZ	5342011867236	19207	12339247-1	MOUNT,RESILIENT LOWER FRONT.....	2
6	PAHZZ	5310014769321	19207	12339248-3	SPACER,RING L.H.,FRONT.....	1
6	PAHZZ	5310012527285	19207	12339248-2	WASHER,FLAT BODY MOUNT,RIGHT FRONT AND REAR.....	2
7	PAHZZ	5310011304274	24617	9422305	NUT,SELF-LOCKING,HE 5/8-11.....	6
8	PAHZZ	5365011861294	34623	5569268	SPACER,SLEEVE INTERMEDIATE.....	2
9	PAHZZ	5340012097802	19207	12339244-3	MOUNT,RESILIENT UPPER INTERMEDIATE.	2
10	PAHZZ	5342014066962	19207	12339247-3	MOUNT,RESILIENT LOWER INTERMEDIATE.	2
11	PAHZZ	5365012144987	34623	5583215	SPACER,RING INTERMEDIATE.....	2
12	PAHZZ	5305007247254	80204	B1821BH063C400N	SCREW,CAP,HEXAGON H INTERMEDIATE, R.H., 5/8-11 X 4.00.....	2
12	PAHZZ	5305007247264	80204	B1821BH063C450N	SCREW,CAP,HEXAGON H INTERMEDIATE, L.H.,5/8-11 X 4.50.....	2
13	PAHZZ	5365012644023	19207	12339249-1	SPACER,SLEEVE REAR.....	2
14	PAHZZ	5342011895452	34623	5569270	MOUNT,RESILIENT UPPER REAR.....	2
					UOC:A11,A13,A14,A20,A24,A25,A26,A27, B17,B18,B20,B24,B25,C17,H11,H13,H14, H17,H18,H20,H24,H25,H26,H27,MMM	
14	PAHZZ	5340012097802	19207	12339244-3	MOUNT,RESILIENT UPPER REAR.....	2
					UOC:AVY,A15,BVY,B15,B16,HVY,H15,H16, H21,H28,NNN	
15	PAHZZ	5342011867236	19207	12339247-1	MOUNT,RESILIENT LOWER REAR.....	2
					UOC:A11,A13,A14,A20,A24,A25,A26,A27, B17,B18,B20,B24,B25,C17,H11,H13,H14, H17,H18,H20,H24,H25,H26,H27,MMM	
15	PAHZZ	5342014066962	19207	12339247-3	MOUNT,RESILIENT LOWER REAR.....	2
					UOC:AVY,A15,BVY,B15,B16,HVY,H15,H16, H21,H28,NNN	
16	PAHZZ	5305007247263	80204	B1821BH063C425N	SCREW,CAP,HEXAGON H REAR,5/8-11 X 4.25.....	2
					UOC:A11,A13,A14,A20,A24,A25,A26,A27, B17,B18,B20,B24,B25,C17,H11,H13,H14, H17,H18,H20,H24,H25,H26,H27,MMM	
16	PAHZZ	5305007247264	80204	B1821BH063C450N	SCREW,CAP,HEXAGON H BODY MOUNT REAR,5/8-11 X 4.50.....	2
					UOC:AVY,A15,BVY,B15,B16,HVY,H15,H16, H21,H28,NNN	

END OF FIGURE

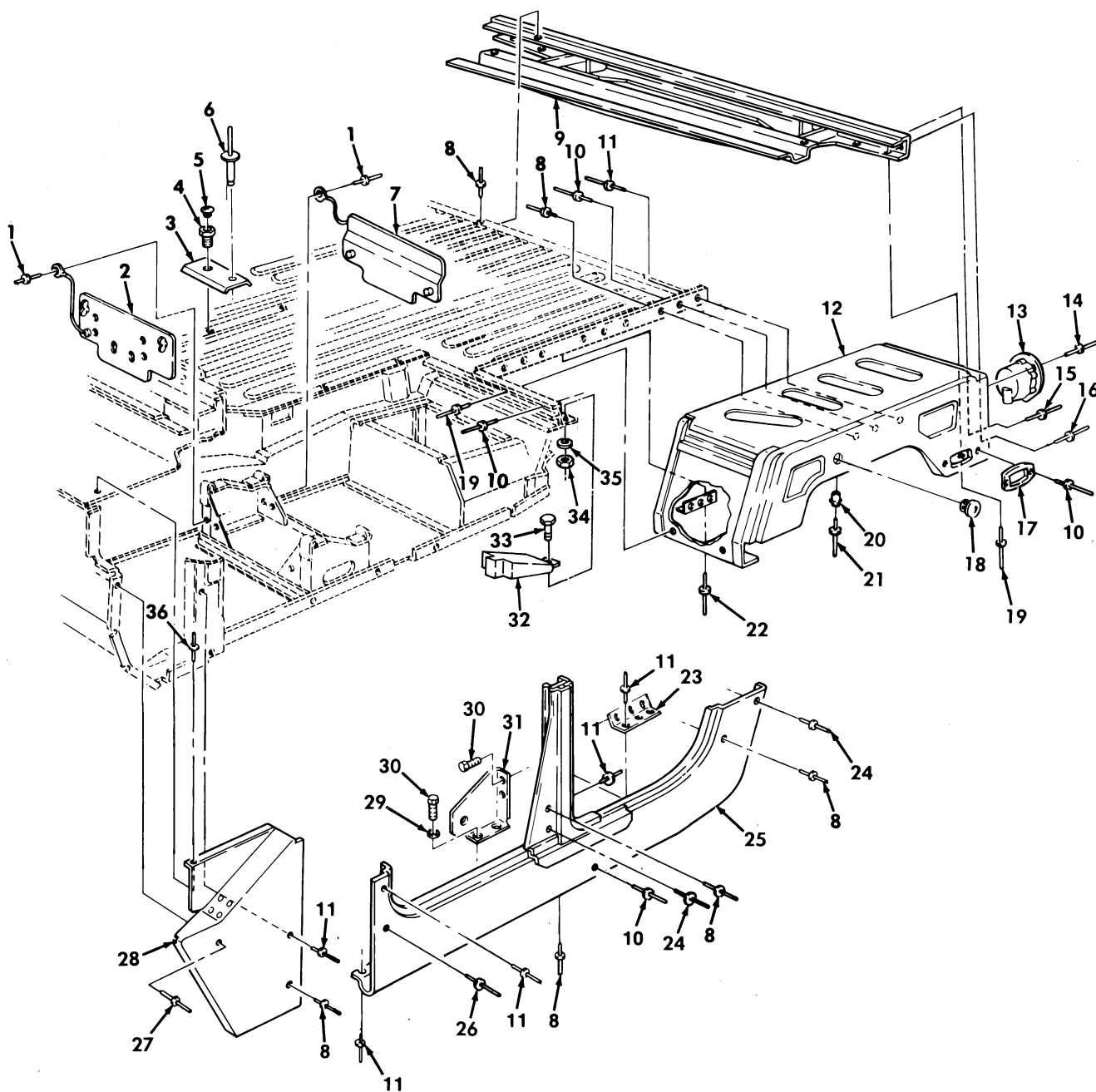

Figure 197. Body Assembly Components, Left Hand.

SECTION II		TM9-2320-280-24P			(6)	(7)
(1)	(2)	(3)	(4)	(5)		
ITEM	SMR			PART		
NO	CODE	NSN	CAGEC	NUMBER	DESCRIPTION AND USABLE ON CODES(UC)	QTY
GROUP 1801 BODY,CAB,HOOD,AND HULL ASSEMBLY						
FIG. 197 BODY ASSEMBLY COMPONENTS, LEFT HAND						
1	PAOZZ	5320000835009	11078	ADS43	RIVET,BLIND 1/8 DIA.....	2
2	PFOZZ	2540011975448	19207	12339026	SUPPORT,SEAT,VEHICU FRONT.....	1
3	PAOZZ	5340013336038	19207	12342295	BRACKET,DOUBLE ANGL RADIO RACK.....	4
4	PAOZZ	5310011981724	03481	S31P280	NUT,PLAIN,BLIND RIV RADIO RACK.....	4
5	PAOZZ	5340012646104	20768	207-180201-0101	BUTTON,PLUG.....	4
6	PAOZZ	5320012544251	34623	5593050	RIVET,BLIND.....	8
7	PFOZZ	2540011975447	19207	12339027	SUPPORT,SEAT,VEHICU REAR.....	1
8	PAFZZ	5320011361782	11815	CR3213-6-4	RIVET,BLIND 3/16 DIA.,USBL EFF 100, 000 AND ABOVE.....	21
8	PAFZZ	5320011361782	11815	CR3213-6-4	RIVET,BLIND 3/16 DIA.,USBL EFF 1 THRU 99,999.....	19
UC:H11,H13,H14,H15,H16,H17,H18,H20, H21,H24,H25,H26,H27,H28,MMM						
9	PFFZZ	2590014109968	34623	12446928	BRACKET,VEHICULAR C REAR,D-BEAM....	1
10	PAFZZ	5320010861143	11815	CR3213-6-9	RIVET,BLIND 3/16 DIA.....	52
11	PAFZZ	5320011357319	11815	CR3213-6-3	RIVET,BLIND 3/16 DIA.....	101
12	PFFFF	2510013354171	19207	12339701-1	FENDER,VEHICULAR LEFT SIDE REAR....	1
13	PFOZZ	5342011943128	34623	5575569	BRACKET TAILLAMP HOUSING.....	1
14	PAOZZ	5320012751998	11815	BAPKTR-64	RIVET,BLIND 3/16 DIA.....	8
15	PAFZZ	5320001176856	96906	MS20470AD6-12	RIVET,SOLID USE WITH ITEM 9,P/N 12446928.....	32
UC:AVY,A11,A13,A14,A20,A24,A25,A26, A27,BVY,B17,B18,B20,B24,B25,C17,HVY, H11,H13,H14,H17,H18,H20,H21,H24,H25, H26,H27,H28,MMM,NNN						
15	PAFZZ	5320001176856	96906	MS20470AD6-12	RIVET,SOLID USE WITH ITEM 9,P/N 12446928.....	24
UC:A15,B15,B16,H15,H16						
15	PAFZZ	5320001176853	96906	MS20470AD6-8	RIVET,SOLID USE WITH ITEM 9,P/N 12338758.....	36
UC:AVY,A11,A13,A14,A20,A24,A25,A26, A27,B17,B18,H11,H13,H14,H17,H18,H20, H21,H24,H25,H26,H27,H28,MMM						
15	PAFZZ	5320001176853	96906	MS20470AD6-8	RIVET,SOLID USE WITH ITEM 9,P/N 12338758.....	28
UC:A15,B16,H15,H16						
16	PAFZZ	5320014076239	80205	NAS9303B-6-06	RIVET,BLIND USE WITH ITEM 9,P/N 12446928.....	8
UC:A15,B15,B16,H15,H16						
16	PAFZZ	5320014076239	80205	NAS9303B-6-04	RIVET,BLIND USE WITH ITEM 9,P/N 12338758.....	8
UC:A15,B15,B16,H15,H16						
17	PFFZZ	6220012000897	19207	12338709	HOUSING,LIGHT MARKER.....	1
18	PAOZZ	5340012031980	28520	2683	CAP-PLUG,PROTECTIVE.....	2
19	PAFZZ	5320010859995	11815	CR3213-6-7	RIVET,BLIND 3/16 DIA.....	17
20	PAFZZ	5320010750367	80204	NAS1080R06	COLLAR,GROOVED PIN.....	2
21	PAFZZ	5320013335545	81349	M23469/2-50605	PIN-RIVET,GROOVED.....	2

SECTION II			TM9-2320-280-24P			
(1)	(2)	(3)	(4)	(5)	(6)	(7)
ITEM	SMR			PART		
NO	CODE	NSN	CAGEC	NUMBER	DESCRIPTION AND USABLE ON CODES(UC)	QTY
22	PAFZZ	5320007219062	96906	MS20470AD6-10	RIVET,SOLID 3/16 DIA.....	16
23	PFFZZ	5340012533757	19207	12338667	BRACKET,ANGLE.....	1
24	PAFZZ	5320010849235	11815	CR3213-6-5	RIVET,BLIND 3/16 DIA.....	7
25	PFFZZ	2510013357799	19207	12339698-3	PANEL,BODY,VEHICULA.....	1
26	PAFZZ	5320010846101	11815	CR3212-6-3	RIVET,BLIND 3/16 DIA.....	3
27	PAFZZ	5320011435075	11815	CR3213-6-2	RIVET,BLIND 3/16 DIA.....	21
28	PAFZZ	2510011863106	19207	12338734	COWL PANEL,VEHICULA.....	1
29	PAOZZ	5310008094058	96906	MS27183-10	WASHER,FLAT 1/4.....	2
30	PAOZZ	5305000687837	80204	B1821BH025C063N	SCREW,CAP,HEXAGON H 1/4-20 X 5/8...	4
31	PAOZZ	5340012468282	19207	12339988-1	BRACKET,MOUNTING L.H.....	1
32	PFFZZ	5330012525377	34623	5581162	SEAL ASSEMBLY.....	1
33	PAFZZ	5305002400194	96906	MS51849-76	SCREW,MACHINE #10-24 X 3/4.....	1
34	PAFZZ	5310011861245	7X677	9423869	NUT,SELF-LOCKING,HE #10-24.....	1
35	PAFZZ	5310000120391	24617	120391	WASHER,FLAT 5/16.....	1
36	PAFZZ	5320001176853	96906	MS20470AD6-8	RIVET,SOLID.....	4

UOC:BVY,B15,B20,B24,B25,C17,NNN

END OF FIGURE

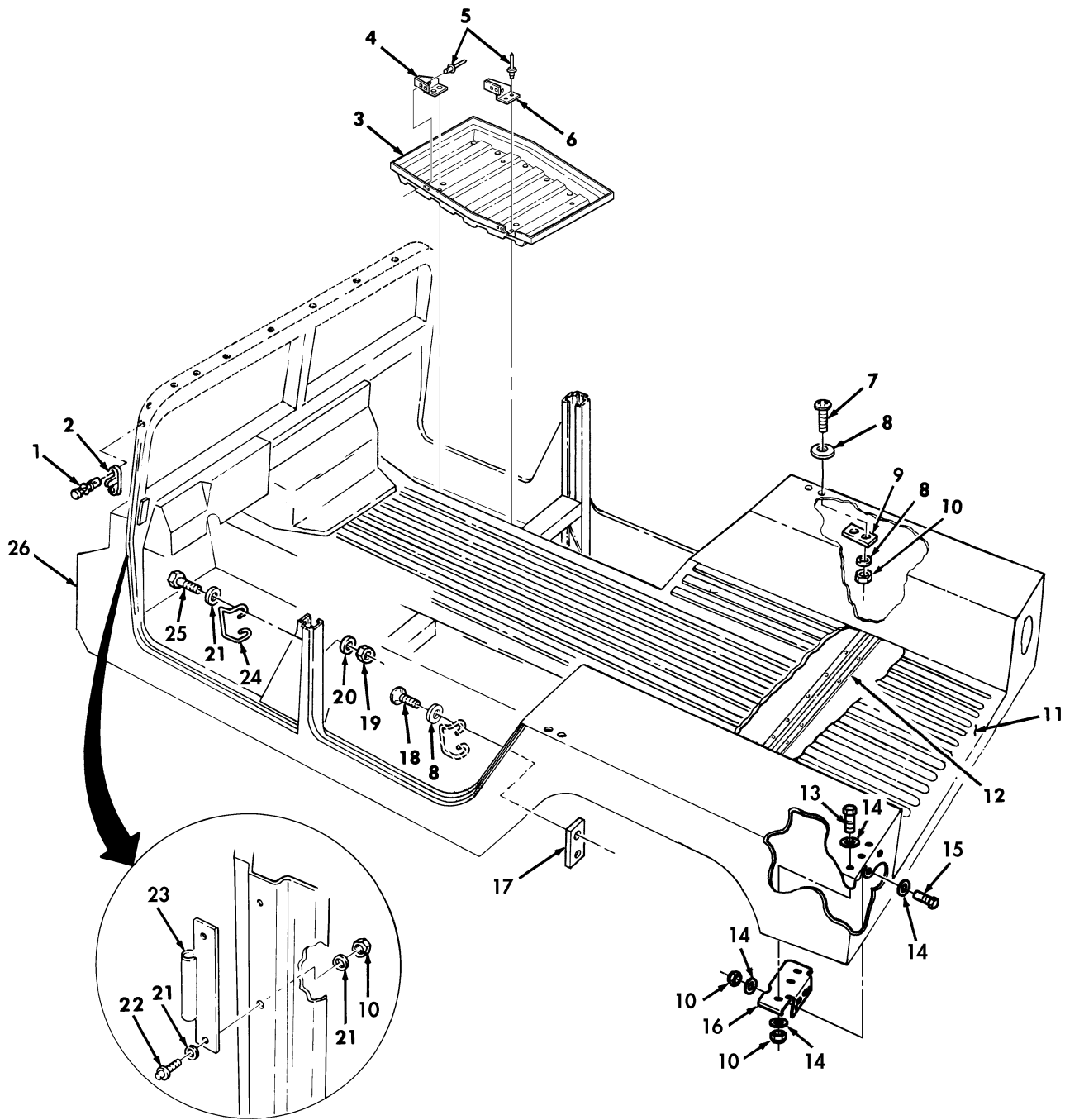

Figure 198. Body Assembly and Related Parts.

SECTION II			TM9-2320-280-24P			
(1)	(2)	(3)	(4)	(5)	(6)	(7)
ITEM NO	SMR CODE	NSN	CAGEC	PART NUMBER	DESCRIPTION AND USABLE ON CODES(UC)	QTY
GROUP 1801 BODY,CAB,HOOD,AND HULL ASSEMBLY						
FIG. 198 BODY ASSEMBLY AND RELATED PARTS						
1	PAOZZ	5320010232529	81349	M24243/1-A404	RIVET,BLIND 1/8 DIA.....	4
2	PAOZZ	5325008235999	13940	XB78323-05001	STUD,TURNBUTON FAS WINDSHIELD.....	2
3	PAOZZ	6160014704172	19207	12338765	TRAY,BATTERY FLOOR PLAN.....	1
4	PAOZZ	5340014707135	19207	12339904	BRACKET,BATTERY FRONT.....	1
5	PAOZZ	5320007540992	96906	MS20470AD6-7	RIVET,SOLID.....	8
6	PAOZZ	5340014707160	19207	12339905	BRACKET,BATTERY REAR.....	1
7	PAOZZ	5305000180024	24617	180024	SCREW,MACHINE 1/4-20 X .88.....	12
8	PAOZZ	5310001870146	24617	120392	WASHER,FLAT 1/4.....	24
9	PAOZZ	5340012559510	19207	12339009	PLATE,MENDING REINFORCEMENT,C-PILLAR.....	6
10	PAOZZ	5310014326727	24617	9419471	NUT,SELF-LOCKING,HE 1/4-20.....	16
11	PBFHH	2510012626010	34623	5588702	PANEL,BODY,VEHICULA CARGO FLOOR....	1
12	PFFHH	2510012626007	19207	12338740	PANEL REPAIR,24 X 24 INCHES FRAME SECTION,STRU CARGO FLOOR SUPPORT.....	3
13	PAOZZ	5305012114505	51387	180021	SCREW,CAP,HEXAGON H.....	6
14	PAOZZ	5310011036042	24617	120392	WASHER,FLAT.....	16
15	PAOZZ	5306013714685	29510	180022	BOLT,MACHINE.....	4
16	PAOZZ	5340014705892	19207	12339031-1	BRACKET,RETAINER L.H.....	1
16	PAOZZ	5340014336262	19207	12339031-2	BRACKET,RETAINER R.H.....	1
17	PAOZZ	5340011975477	34623	5584423	RETAINER,ASSEMBLED REAR DOOR STRIKER	2
18	PAOZZ	5305009881727	96906	MS35206-283	SCREW,MACHINE 1/4-20 X 3/4.....	4
19	PBHHH	5310002416658	96906	MS51942-34	NUT,SELF-LOCKING,HE 5/16-24.....	4
20	PAOZZ	5310000814219	96906	MS27183-12	WASHER,FLAT 5/16.....	8
21	PAOZZ	5310011023270	24617	2436161	WASHER,,FLAT.....	8
22	PAOZZ	5306013235534	19207	12340352-2	BOLT,MACHINE TOP FRONT HINGE,1/4-20 X 7/8 2-DOOR.....	8
22	PAOZZ	5306013235535	34623	5585259-B	BOLT MACHINE BOTTOM FRONT HINGE.... AND TOP AND BOTTOM REAR HINGE, 1/4-20 X 3/4 4-DOOR.....	12
23	PAOZZ	5342012032822	19207	13338650	MOUNT,RESILIENT.....	8
24	PAOZZ	5340012070717	34623	5581362	BUCKET FRONT.....	2
25	PAOZZ	5306001822027	88044	AN5H10A	BOLT,MACHINE 5/16-24 X 1.00.....	4
26	PBHHH	2510013592076	34623	12446861	FRAME,STRUCTURAL,VE COMPLETE.....	1
26	PBHHH	2510012626011	19207	12446868	UC:AVY,A11,A13,A14,A15,A20,A24,A25, A26,A27,BVY,B15,B16,B17,B18,B20,B24, B25,C17,HVY,NNN FRAME SECTION,STRU REPLACEMENT BODY ASSEMBLY..... UC:H11,H13,H14,H15,H16,H17,H18,H20, H21,H24,H25,H26,H27,H28,MMM	1

END OF FIGURE

3 — 

4 thru 14
-----------------

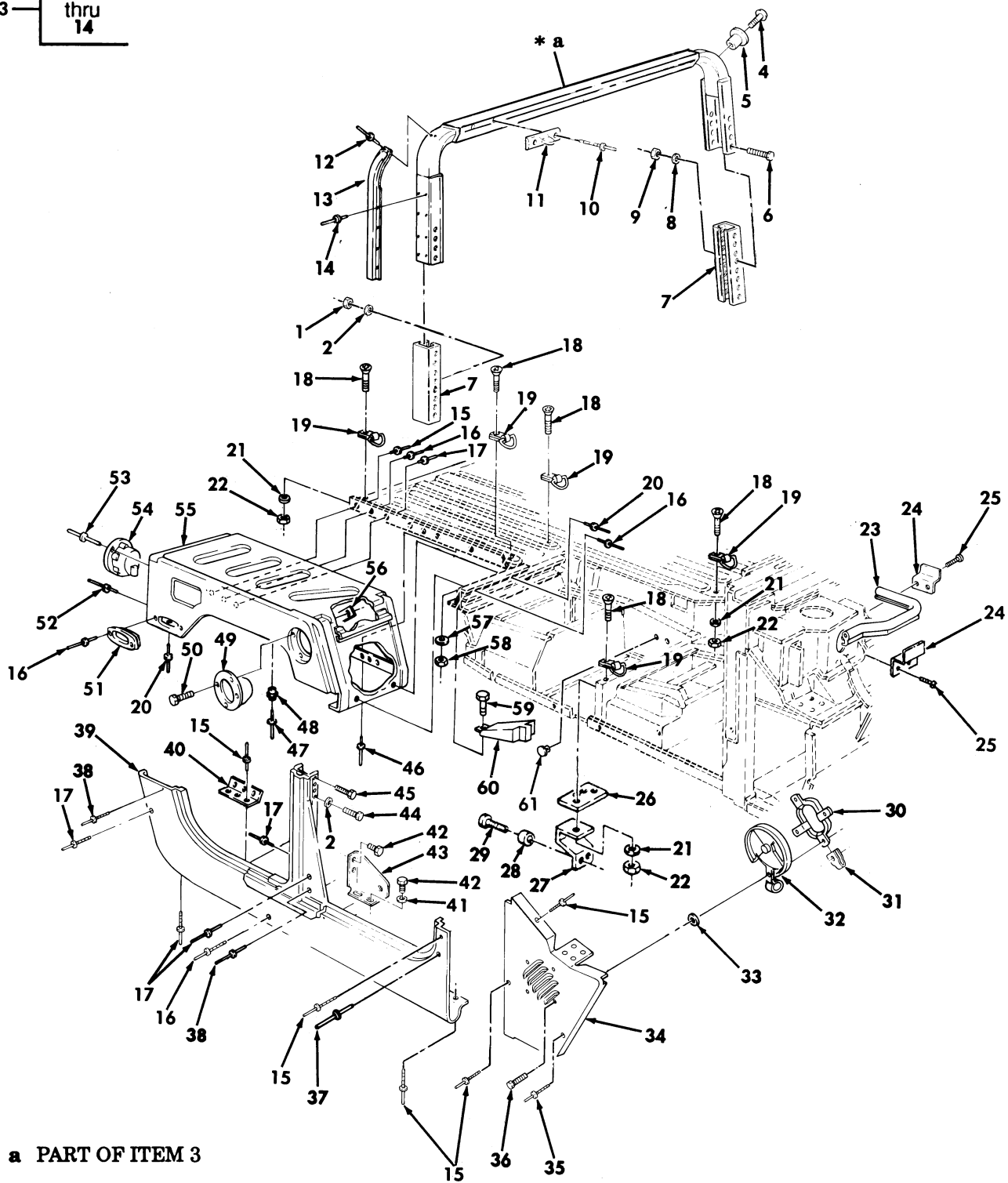

\* a PART OF ITEM 3

Figure 199. Body Assembly Components, Right Hand.



SECTION II			TM9-2320-280-24P			
(1)	(2)	(3)	(4)	(5)	(6)	(7)
ITEM NO	SMR CODE	NSN	CAGEC	PART NUMBER	DESCRIPTION AND USABLE ON CODES(UOC)	QTY
					GROUP 1801 BODY,CAB,HOOD,AND HULL ASSEMBLY	
					FIG. 199 BODY ASSEMBLY COMPONENTS, RIGHT HAND	
1	PAOZZ	5310002416658	96906	MS51943-34	NUT,SELF-LOCKING,HE 5/16-24.....	16
					UOC:AVY,A13,A14,A20,BVY,B20,HVY,H13,H14,H20,H21,H28,NNN	
2	PAOZZ	5310000814219	96906	MS27183-12	WASHER,FLAT 5/16.....	20
					UOC:AVY,A13,A14,A20,BVY,B20,HVY,H13,H14,H20,H21,H28,NNN	
3	PAOFF	2540013354482	19207	12339196-1	ROLL BAR,VEHICULAR.....	1
					UOC:AVY,A13,A14,A20,BVY,B20,HVY,H13,H14,H20,H21,H28,NNN	
4	PAOZZ	5305011858647	7X677	160057	.SCREW,MACHINE #10-32 X 3/4.....	2
					UOC:AVY,A13,A14,A20,BVY,B20,HVY,H13,H14,H20,H21,H28,NNN	
5	PAOZZ	5310007557283	19207	12339397-1	.NUT,SLEEVE #10-32.....	2
					UOC:AVY,A13,A14,A20,BVY,B20,HVY,H13,H14,H20,H21,H28,NNN	
6	PAOZZ	5305014079487	80204	B1821BH031F088N	.SCREW,CAP,HEXAGON H 5/16-24 X 27/32	16
					UOC:AVY,A13,A14,A20,BVY,B20,HVY,H13,H14,H20,H21,H28,NNN	
7	PAOZZ	2590012477910	19207	12339194	.BLOCK,CONNECTOR,ROL B-PILLAR.....	2
					UOC:AVY,A13,A14,A20,BVY,B20,HVY,H13,H14,H20,H21,H28,NNN	
8	PAOZZ	5310013080131	81306	120393	.WASHER,FLAT 5/16.....	16
					UOC:AVY,A13,A14,A20,BVY,B20,HVY,H13,H14,H20,H21,H28,NNN	
9	PAOZZ	5310009843807	24617	9419476	.NUT,SELF-LOCKING,HE 5/16-24.....	16
					UOC:AVY,A13,A14,A20,BVY,B20,HVY,H13,H14,H20,H21,H28,NNN	
10	PAOZZ	5320010232529	81349	M24243/1-A404	.RIVET,BLIND 1/8 DIA.....	46
					UOC:AVY,A13,A14,A20,BVY,B20,HVY,H13,H14,H20,H21,H28,NNN	
11	PAOZZ	5325008235999	13940	XB78323-05001	.STUD,TURNBUTTON FAS B-PILLAR.....	23
					UOC:AVY,A13,A14,A20,BVY,B20,HVY,H13,H14,H20,H21,H28,NNN	
12	PAOZZ	5320012716357	9K475	MGLP-B6-4	.RIVET,BLIND BAR,.062-.270 GRIP....	16
					UOC:AVY,A13,A14,A20,BVY,B20,HVY,H13,H14,H20,H21,H28,NNN	
13	XAOZZ		19207	12339188	.RABBET,"B" ROLL BAR.....	2
					UOC:AVY,A13,A14,A20,BVY,B20,HVY,H13,H14,H20,H21,H28,NNN	
14	PAOZZ	5320012645978	9K475	MGLP-B6-7	.RIVET,BLIND .214-.437 GRIP.....	4
					UOC:AVY,A13,A14,A20,BVY,B20,HVY,H13,H14,H20,H21,H28,NNN	
15	PAFZZ	5320011357319	11815	CR3213-6-3	RIVET,BLIND 3/16 DIA.....	130
16	PAFZZ	5320010861143	11815	CR3213-6-9	RIVET,BLIND 3/16 DIA.....	52
17	PAFZZ	5320011361782	11815	CR3213-6-4	RIVET,BLIND 3/16 DIA.,USBL EFF 100,	21
					000 AND ABOVE.....	
17	PAFZZ	5320011361782	11815	CR3213-6-4	RIVET,BLIND 3/16 DIA.,USBL EFF 1	19

SECTION II			TM9-2320-280-24P			
(1)	(2)	(3)	(4)	(5)	(6)	(7)
ITEM NO	SMR CODE	NSN	CAGEC	PART NUMBER	DESCRIPTION AND USABLE ON CODES(UOC)	QTY
18	PAOZZ	5305000522232	96906	MS24667-77	THRU 99,999..... SCREW,CAP,HEXAGON H 1/2-13 X 1.75..	8
					UOC:BVY,B15,B20,B24,NNN	
18	PAOZZ	5305000522232	96906	MS24667-77	SCREW,CAP,SOCKET HE 1/2-13 X 1.75..	8
					UOC:A13,A14,H13,H14	
18	PAOZZ	5305000522232	96906	MS24667-77	SCREW,CAP,SOCKET HE 1/2-13 X 1.75..	6
					UOC:A11,H11,MMM	
18	PAOZZ	5305000522232	96906	MS24667-77	SCREW,CAP,SOCKET HE 1/2-13 X 1.75..	9
					UOC:B17,B18,C17,H17,H18	
18	PAOZZ	5305000522232	96906	MS24667-77	SCREW,CAP,SOCKET HE 1/2-13 X 1.75..	7
					UOC:A25,A26,B25,C17,H25,H26	
19	PAOZZ	3990014325370	19207	12446987	TIE DOWN,CARGO,VEHI.....	8
					UOC:BVY,B15,B20,B24,NNN	
19	PAOZZ	3990013148393	19207	12342077	TIE DOWN,CARGO,VEHI CARGO TIEDOWN..	8
					UOC:A13,A14,H13,H14	
19	PAOZZ	3990013148393	19207	12342077	TIE DOWN,CARGO,VEHI CARGO TIEDOWN..	6
					UOC:A11,H11,MMM	
19	PAOZZ	3990013148393	19207	12342077	TIE DOWN,CARGO,VEHI CARGO TIEDOWN..	9
					UOC:B17,B18,H17,H18	
19	PAOZZ	3990013148393	19207	12342077	TIE DOWN,CARGO,VEHI CARGO TIEDOWN..	7
					UOC:A25,A26,B25,H25,H26	
20	PAFZZ	5320010859995	11815	CR3213-6-7	RIVET,BLIND 3/16 DIA.....	17
21	PAOZZ	5310001670823	88044	AN960-816	WASHER,FLAT 1/2.....	8
					UOC:A13,A14,BVY,B15,B20,B24,H13,H14, H20,H24,H27,NNN	
21	PAOZZ	5310001670823	88044	AN960-816	WASHER,FLAT 1/2.....	9
					UOC:B17,B18,C17,H17,H18	
21	PAOZZ	5310001670823	88044	AN960-816	WASHER,FLAT 1/2.....	7
					UOC:A25,A26,B25,H25,H26	
21	PAOZZ	5310001670823	88044	AN960-816	WASHER,FLAT 1/2.....	6
					UOC:A11,H11,MMM	
22	PAOZZ	5310004883889	96906	MS51943-39	NUT,SELF-LOCKING,HE 1/2-13.....	8
					UOC:BVY,B15,B20,B24,NNN	
22	PAOZZ	5310004883889	96906	MS51943-39	NUT,SELF-LOCKING,HE 1/2-13.....	6
					UOC:A11,H11,MMM	
22	PAOZZ	5310004883889	96906	MS51943-39	NUT,SELF-LOCKING,HE 1/2-13.....	9
					UOC:B17,B18,C17,H17,H18	
22	PAOZZ	5310004883889	96906	MS51943-39	NUT,SELF-LOCKING,HE 1/2-13.....	7
					UOC:A25,A26,BVY,B15,B20,B24,B25,H25, H26,NNN	
22	PAOZZ	5310004883889	96906	MS51943-39	NUT,SELF-LOCKING,HE 1/2-13.....	8
					UOC:A13,A14,BVY,B15,B20,B24,H13,H14, H17,H18,H24,H25,H26,H27,NNN	
23	MOOZZ		34623	5581213	SEAL,RUBBER UPPER HOOD,R.H. COWL, MAKE FROM SEAL,P/N 1403,17.25 INCHES LONG.....	1
24	PFOZZ	5340012070379	19207	12338814	BRACKET,DOUBLE ANGL INNER,HOOD SEAL	1
24	PAOZZ		19207	12340869	BRACKET,DOUBLE ANGL FRONT SIDE.....	1
25	PAOZZ	5305012542460	34623	5592840	SCREW,TAPPING,THREA #10-16 X 1/2...	4
26	PAFZZ	2510014112736	19207	12338670	FRAME SECTION,STRUC.....	3
					UOC:BVY,B15,B20,B24,B25,C17,NNN	
27	PAFZZ	2510014107169	19207	12446988	FRAME SECTION,STRUC.....	3
					UOC:BVY,B15,B20,B24,B25,C17,NNN	

SECTION II			TM9-2320-280-24P			
(1)	(2)	(3)	(4)	(5)	(6)	(7)
ITEM	SMR			PART		
NO	CODE	NSN	CAGEC	NUMBER	DESCRIPTION AND USABLE ON CODES(UOC)	QTY
28	PAFZZ	5320002057917	80205	NAS1080R08	COLLAR,GROOVED PIN.....	6
					UOC:BVY,B15,B20,B24,B25,C17,NNN	
29	PAFZZ	5320014124877	81349	M23469/2-50809	PIN-RIVET,GROOVED.....	6
					UOC:BVY,B15,B20,B24,B25,C17,NNN	
30	PFOZZ	2540011924500	19207	12338849	RETAINER,AIR DUCT OUTSIDE AIR.....	1
31	PAOZZ	5310012155356	78553	C8117-1024	NUT,SHEET SPRING #10-24.....	4
32	PFOZZ	2510011925947	19207	12339222	GRILLE,METAL OUTSIDE AIR.....	1
33	PAOZZ	5310000145850	96906	MS27183-42	WASHER,FLAT #10.....	4
34	PFFZZ	2510011863107	19207	12338716	COWL PANEL,VEHICULA OUTER,R.H.....	1
35	PAFZZ	5320011435075	11815	CR3213-6-2	RIVET,BLIND 3/16 DIA.....	5
36	PAOZZ	5305012529108	34623	5592994	SCREW,TAPPING #10-16 X 7/8.....	4
37	PAFZZ	5320010846101	11815	CR3212-6-3	RIVET,BLIND 3/16 DIA.....	3
38	PAFZZ	5320010849235	11815	CR3213-6-5	RIVET,BLIND 3/16 DIA.....	7
39	PFFZZ	2510011857958	34623	5575503	BODY PANEL,VEHICULA R.H.,USBL EFF	1
					1 THRU 99,999.....	
					UOC:H11,H13,H14,H15,H16,H17,H18,H20,	
					H21,H24,H25,H26,H27,H28,MMM	
39	PFFZZ	2510013618213	19207	12339698-4	PANEL,BODY,VEHICULA R.H.,USBL EFF	1
					100,000 AND ABOVE.....	
40	PFFZZ	5340012533757	34623	5575418	BRACKET,ANGLE SIDE PANEL.....	1
41	PAOZZ	5310008238803	96906	MS27183-21	WASHER,FLAT 1/4.....	2
42	PAOZZ	5305000687837	80204	B1821BH025C063N	SCREW,CAP,HEXAGON H 1/4-20 X 5/8...	4
43	PAOZZ	5340012487646	19207	12339988-2	BRACKET,MOUNTING R.H.....	1
44	PAOZZ	5306001822027	88044	AN5H10A	BOLT,MACHINE 5/16-24 X 1.25.....	4
					UOC:AVY,A13,A14,A20,BVY,B20,HVY,H13,	
					H14,H20,H21,H28,NNN	
45	PAOZZ	5306001822025	88044	AN5H6A	BOLT,MACHINE 5/16-24 X 27/32.....	12
46	PAFZZ	5320007219062	96906	MS20470AD6-10	RIVET,SOLID 3/16 DIA.....	16
47	PAFZZ	5320013335545	81349	M23469/2-30605	PIN-RIVET,GROOVED FENDER ASSEMBLY..	2
48	PAFZZ	5320008646203	17446	6LC-2R06	COLLAR,GROOVED PIN- .288 O.D.,.189	2
					I.D.....	
49	PFOZZ	2590011975446	19207	12339048	FILLER NECK.....	1
50	PAOZZ	5305012645874	19207	12340792	SCREW,TAPPING #10-12 X .75.....	6
51	PFOZZ	6220012000897	19207	12338709	HOUSING,LIGHT RIGHT SIDE,REAR.....	1
52	PAFZZ	5320001176853	96906	MS20470AD6-8	RIVET,SOLID 3/16 DIA.....	18
53	PAOZZ	5320012751998	11815	BAPKTR-64	RIVET,BLIND 3/16 DIA.....	8
54	PFOZZ	5342011943128	34623	5575569	BRACKET HOUSING.....	1
55	PFFZZ	2510013354170	19207	12339707-1	FENDER,VEHICULAR RIGHT REAR.....	1
56	PAOZZ	5310011947066	72800	C7685-10A	NUT,SHEET SPRING.....	6
57	PAFZZ	5310000145850	96906	MS27183-42	WASHER,FLAT #10.....	1
58	PAFZZ	5310012530058	34623	5592999	NUT,SELF-LOCKING,EX #10-24.....	1
59	PAFZZ	5305002400194	96906	MS51849-76	SCREW,MACHINE #10-24 X 3/4.....	1
60	PFFZZ	5330012525378	34623	5581163	SEAL ASSEMBLY RIGHT SIDE FRONT.....	1
61	PAOZZ	5340012031980	28520	2683	PLUG,PROTECTIVE BODY PANEL.....	2

END OF FIGURE

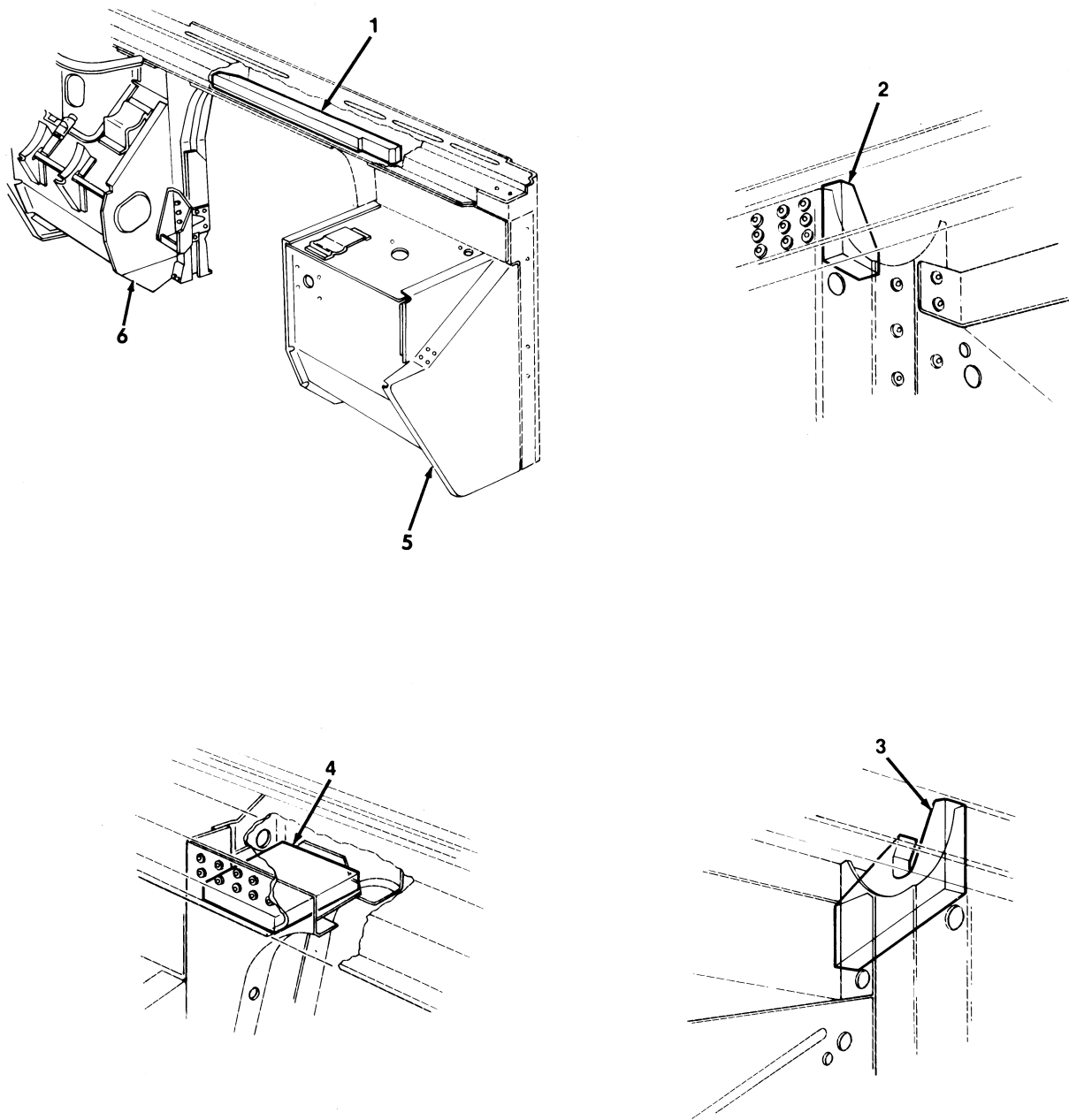
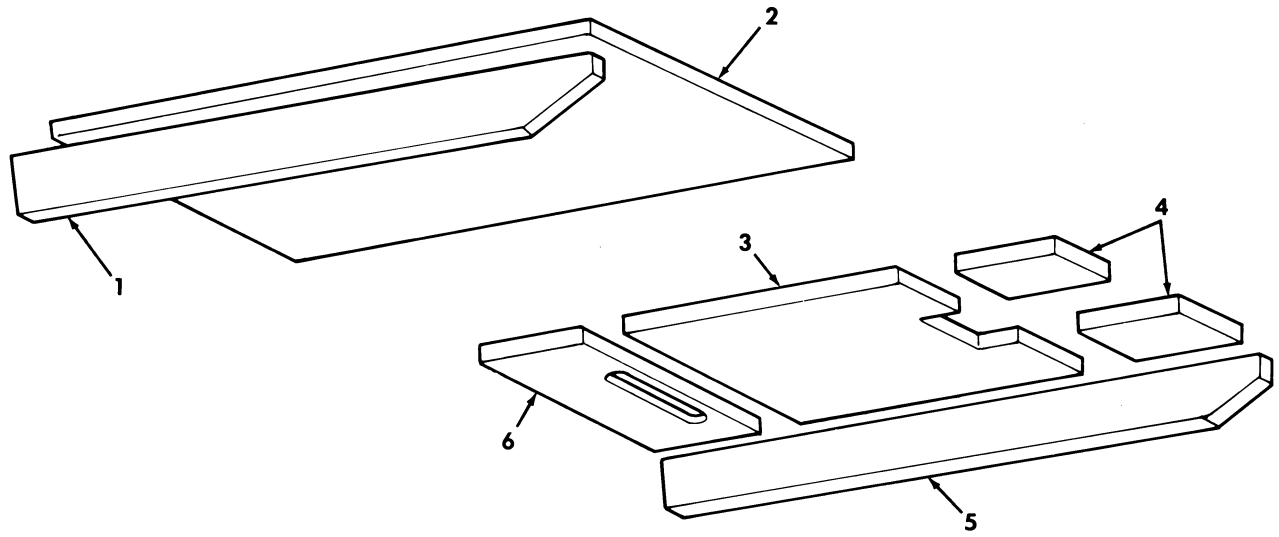

Figure 200. Body Insulation and Cowl Assemblies.

SECTION II			TM9-2320-280-24P			
(1)	(2)	(3)	(4)	(5)	(6)	(7)
ITEM	SMR			PART		
NO	CODE	NSN	CAGEC	NUMBER	DESCRIPTION AND USABLE ON CODES(UC)	QTY
					GROUP 1801 BODY,CAB,HOOD,AND HULL ASSEMBLY	
					FIG. 200 BODY INSULATION AND COWL ASSEMBLIES	
1	PAOZZ	5640013093867	34623	12341888	INSULATION,FILLER CENTER,USBL EFF 46162 AND ABOVE.....	1
2	PAOZZ	5640013093868	34623	12341889	INSULATION,PANEL USBL EFF 46162 AND ABOVE.....	1
3	PAOZZ	5640013093870	34623	SF-5597693	INSULATION,CLOSEOUT L.H.,USBL EFF 46162 AND ABOVE.....	1
4	PAOZZ	5640013093866	34623	SF-5597692	INSULATION,NOZZLE R.H.,USBL EFF 46162 AND ABOVE.....	1
5	PFFHH	2510012626008	19207	12338736	COWL ASSEMBLY,L.H.....	1
6	PFFHH	2510012626009	19207	12338719	COWL ASSEMBLY,R.H.....	1

END OF FIGURE



*Figure 201. Body Insulation.*

SECTION II			TM9-2320-280-24P			
(1)	(2)	(3)	(4)	(5)	(6)	(7)
ITEM	SMR	NSN	CAGEC	PART	DESCRIPTION AND USABLE ON CODES(UOC)	QTY
NO	CODE			NUMBER		
					GROUP 1801 BODY,CAB,HOOD,AND HULL ASSEMBLY	
					FIG. 201 BODY INSULATION	
1	MOOZZ		19207	12342312	INSULATION,PANEL R.H. MAKE FROM PAD,P/N CF40BH52..... UOC:B16,H16	1
2	MOOZZ		19207	12342313	INSULATION,PANEL R.H. MAKE FROM PAD,P/N CF40BH52..... UOC:B16,H16	1
3	MOOZZ		19207	12342309	INSULATION,PANEL L.H. MAKE FROM PAD,P/N CF40BH52..... UOC:B16,H16	1
4	MOOZZ		19207	12342310	INSULATION,PANEL L.H. MAKE FROM PAD,P/N CF40BH52..... UOC:B16,H16	2
5	MOOZZ		19207	12342311	INSULATION,PANEL L.H.,MAKE FROM PAD,P/N CF40BH52..... UOC:B16,H16	1
6	MOOZZ		19207	12342308	INSULATION,PANEL REAR,L.H.,MAKE FROM PAD,P/N CF40BH52..... UOC:B16,H16	1

END OF FIGURE

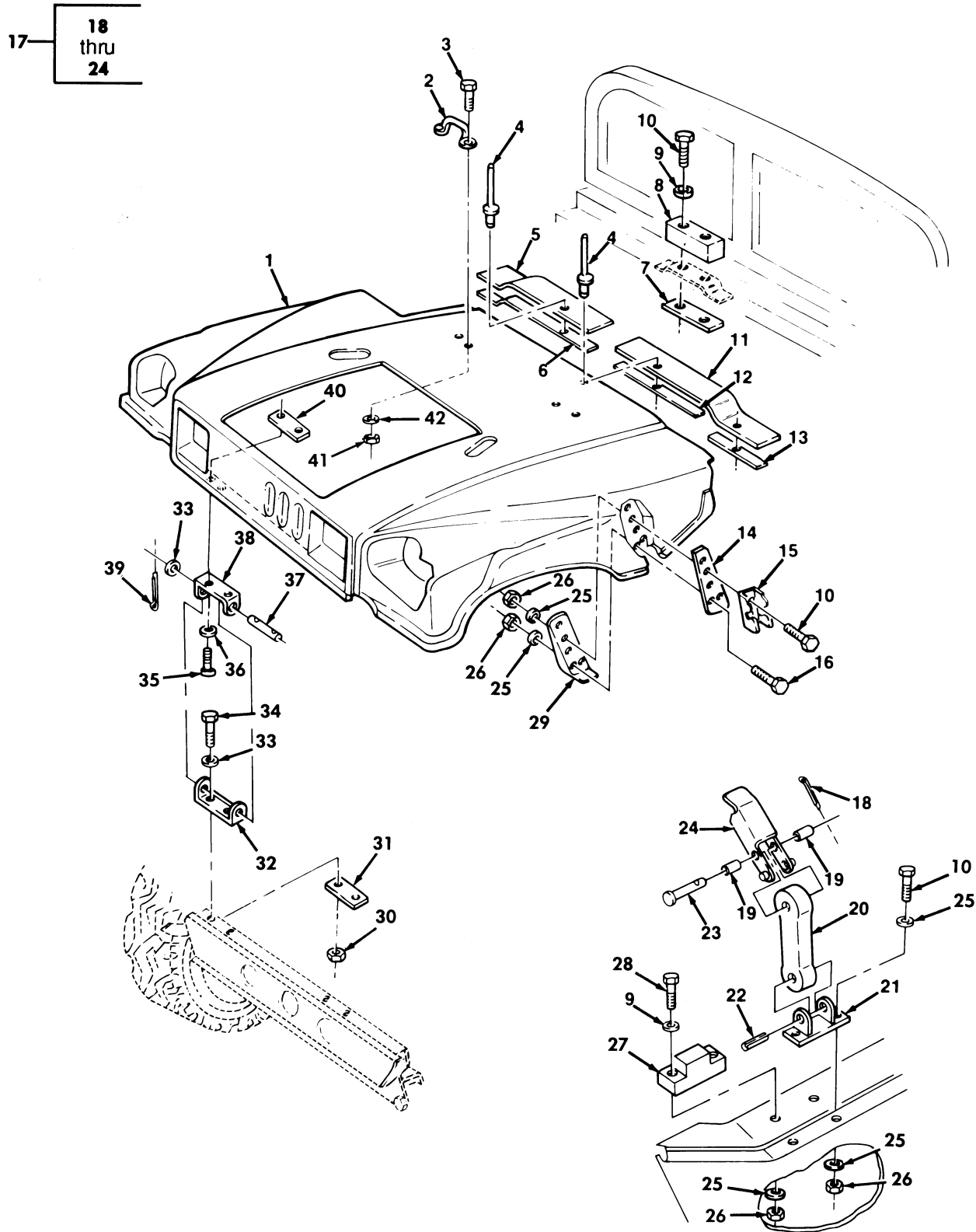

Figure 202. Hood Assembly and Mounting Hardware.



SECTION II			TM9-2320-280-24P			
(1)	(2)	(3)	(4)	(5)	(6)	(7)
ITEM NO	SMR CODE	NSN	CAGEC	PART NUMBER	DESCRIPTION AND USABLE ON CODES(UOC)	QTY
					GROUP 1801 BODY,CAB,HOOD,AND HULL ASSEMBLY	
					FIG. 202 HOOD ASSEMBLY AND MOUNTING HARDWARE	
1	PAOFF	2510014732309	19207	12338940-1	HOOD,ENGINE COMPART COMES WITH GROMMETS AND WELDNUTS.....	1
1	PAOFF	2510011739347	19207	12338940	HOOD,ENGINE COMPART.....	1
2	PAOZZ	5340012135735	34623	5591648	LOOP,STRAP FASTENER.....	2
					UOC:AVY,A13,A14,A20,BVY,B20,HVY,H13,H14,H20,H21,H28,NNN	
3	PAOZZ	5305009846212	96906	MS35206-265	SCREW,MACHINE #10-24 X 3/4.....	4
					UOC:AVY,A13,A14,A20,BVY,B20,HVY,H13,H14,H20,H21,H28,NNN	
4	PAOZZ	5320012556608	11815	SSLQ-68"Q"	RIVET,BLIND 3/16 DIA.....	15
5	PAOZZ	5330012550207	34623	5591313	SEAL,NONMETALLIC ST REAR,R.H.....	1
6	PFOZZ	2590012612636	19207	12338904	BEZEL,AUTOMOTIVE TR REAR,R.H.....	1
7	PAOZZ	5340012662995	34623	5590550	PLATE,MENDING CENTER.....	1
8	PAOZZ	5340011867658	34623	5588172	BUMPER,NONMETALLIC CENTER.....	1
9	PAOZZ	5310012183190	19207	12339433	WASHER,FLAT 9/32.....	6
10	PAOZZ	5305002253842	80204	B1821BH025C113N	SCREW,CAP,HEXAGON H 1/4-20 X 1.125.	6
11	PAOZZ	5330012550208	34623	5591315	SEAL,NONMETALLIC ST REAR,L.H.....	1
12	PFOZZ	2590012612637	19207	12338907	MOLDING,METAL REAR,L.H.....	1
13	PFOZZ	2590012615484	19207	12338902	MOLDING,METAL REAR,L.H.....	1
14	PFOZZ	5340012113132	34623	5584963	PLATE,MENDING.....	2
15	PAOZZ	5340011899979	34623	5588179	STRIKE,CATCH.....	2
16	PAOZZ	5305000712505	80204	B1821BH025C088N	SCREW,CAP,HEXAGON H 1/4-20 X 7/8...	6
17	PAOOO	2540011859530	19207	12338909	LATCH,HOOD,VEHICULA.....	2
18	PAOZZ	5315008395820	80205	MS24665-134	.PIN,COTTER 1/16 X 3/4.....	1
19	PAOZZ	5365012124736	19207	12338886	.SPACER,SLEEVE.....	2
20	PAOZZ	2540012125814	19207	12338889	.LATCH,HOOD,VEHICULA.....	1
21	PAOZZ	2510012090502	19207	12338880	.BASE,HOOD LATCH.....	1
22	PAOZZ	5315007533895	80205	MS16562-256	.PIN,SPRING.....	1
23	PAOZZ	5315012135545	19207	12338894	.PIN,STRAIGHT,HEADED.....	1
24	PAOZZ	2540012094590	19207	12338891	.LATCH,HOOD,VEHICULA.....	1
25	PAOZZ	5310011023270	24617	2436161	WASHER,FLAT 1/4.....	22
26	PAOZZ	5310000614650	96906	MS51943-31	NUT,SELF-LOCKING,HE.....	18
27	PAOZZ	5340011858821	34623	5588167	BUMPER,NONMETALLIC.....	2
28	PAOZZ	5306012668274	34623	9419011	BOLT,MACHINE.....	4
29	PFOZZ	2510011856715	19207	12338905	BRACKET,HOOD VEHICU.....	2
30	PAOZZ	5310008960903	96906	MS51967-12	NUT,PLAIN,HEXAGON.....	4
31	PAOZZ	5365012122325	19207	12338879	SPACER,PLATE.....	1
32	PAOZZ	5340011861388	19207	12338900	LEAF,BUTT HINGE.....	1
33	PAOZZ	5310008094085	96906	MS27183-16	WASHER,FLAT 7/16.....	12
34	PAOZZ	5306012531612	96906	MS35764-850	BOLT,SELF-LOCKING 7/16-14 X 1.25...	4
35	PAOZZ	5305007829489	80204	B1821BH038C200N	SCREW,CAP,HEXAGON H 3/8-16 X 2.00..	4
36	PAOZZ	5310012507836	34623	5593285	WASHER,FLAT 3/8.....	4
37	PAOZZ	5315011865633	19207	12338893	PIN,STRAIGHT,HEADLE.....	2
38	PAOZZ	5340011869496	34623	5578522	LEAF,BUTT HINGE.....	2
39	PAOZZ	5315008423044	14351	X601	PIN,COTTER 3/32 X 3/4.....	4
40	PFOZZ	5310012107938	34623	5582677	NUT STRIP.....	2
41	PAOZZ	5310002081918	88044	AN365-1024A	NUT,SELF-LOCKING,HE #10-24.....	4

SECTION II			TM9-2320-280-24P			
(1)	(2)	(3)	(4)	(5)	(6)	(7)
ITEM	SMR			PART		
NO	CODE	NSN	CAGEC	NUMBER	DESCRIPTION AND USABLE ON CODES(UC)	QTY
42	PAOZZ	5310000145850	96906	MS27183-42	UC:AVY,A13,A14,A20,BVY,B20,HVY,H13, H14,H20,H21,H28,NNN WASHER,FLAT..... UC:AVY,A13,A14,A20,BVY,B20,HVY,H13, H14,H20,H21,H28,NNN	4

END OF FIGURE

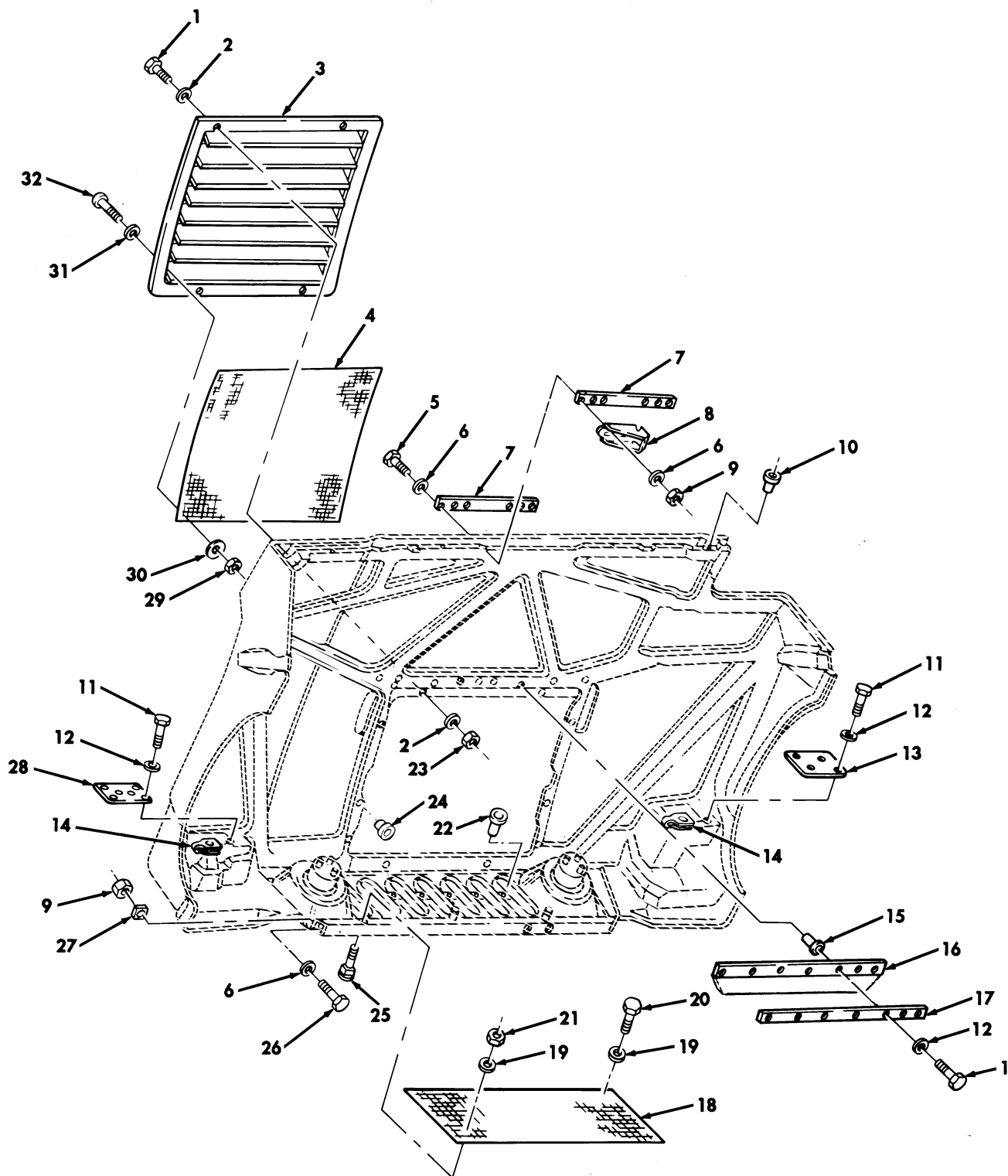

Figure 203. Hood Assembly Grille and Related Parts.

SECTION II			TM9-2320-280-24P			
(1)	(2)	(3)	(4)	(5)	(6)	(7)
ITEM NO	SMR CODE	NSN	CAGEC	PART NUMBER	DESCRIPTION AND USABLE ON CODES(UOC)	QTY
					GROUP 1801 BODY,CAB,HOOD,AND HULL ASSEMBLY	
					FIG. 203 HOOD ASSEMBLY,GRILLE,AND RELATED PARTS	
1	PAOZZ	5305002253843	80204	B1821BH025C100N	SCREW,CAP,HEXAGON H 1/4-20 X 1.00..	15
					UOC:AVY,A13,A14,A20,BVY,B20,HVY,H13,H14,H20,H21,H28,NNN	
2	PAOZZ	5310008093078	96906	MS27183-11	WASHER,FLAT 1/4.....	12
					UOC:AVY,A13,A14,A20,BVY,B20,HVY,H13,H14,H20,H21,H28,NNN	
3	PAOZZ	2510013504949	34623	12342408	GRILLE,RADIATOR,VEH.....	1
					UOC:AVY,A13,A14,A20,BVY,B20,HVY,H13,H14,H20,H21,H28,NNN	
4	PAOZZ	2510011965311	34623	5578749	SCREEN,GRILLE TOP.....	1
					UOC:AVY,A13,A14,A20,BVY,B20,HVY,H13,H14,H20,H21,H28,NNN	
5	PAOZZ	5305002253842	80204	B1821BH025C113N	SCREW,CAP,HEXAGON H 1/4-20 X 1.125.	6
6	PAOZZ	5310011023270	24617	2436161	WASHER,FLAT 1/4.....	14
7	PAOZZ	5365012101629	19207	12338903	SPACER,PLATE.....	2
8	PFOZZ	5340011858619	19207	12338899	BRACKET,ANGLE.....	2
9	PAOZZ	5310000614650	96906	MS51943-31	NUT,SELF-LOCKING,HE 1/4-20.....	8
10	PAOZZ	5340010263250	81349	M5501/7-F2	CAP-PLUG,PROTECTIVE INNER.....	4
11	PAOZZ	5305000680502	96906	MS90725-6	SCREW,CAP,HEXAGON H 1/4-20 X 3/4...	7
12	PAOZZ	5310008094058	96906	MS27183-10	WASHER,FLAT 1/4.....	16
13	PFOZZ	5340012117436	19207	12338884	COVER,ACCESS R.H.....	1
14	PAOZZ	5310012536439	78563	C7740-1420	NUT,SHEET SPRING.....	7
15	PAOZZ	5340012134662	19207	12339397-4	SHIELD,EXPANSION 1/4-20.....	9
16	PAOZZ	5330011928916	19207	12338911	SEAL,NONMETALLIC SP CENTER.....	1
17	PAOZZ	5340011913222	19207	12338885	PLATE,MENDING.....	1
18	PAOZZ	2510011883228	34623	5579485	GUARD,HOOD AND GRIL FRONT.....	1
					UOC:AVY,A13,A14,A20,BVY,B20,HVY,H13,H14,H20,H21,H28,NNN	
19	PAOZZ	5310012507836	34623	5593285	WASHER,FLAT 3/8.....	6
					UOC:AVY,A13,A14,A20,BVY,B20,HVY,H13,H14,H20,H21,H28,NNN	
20	PAOZZ	5305007262525	96906	MS90727-158	SCREW,CAP,HEXAGON H 5/16-18 X 1.00.	3
					UOC:AVY,A13,A14,A20,BVY,B20,HVY,H13,H14,H20,H21,H28,NNN	
21	PAOZZ	5310009318167	96906	MS51967-6	NUT,PLAIN,HEXAGON 5/16-18.....	3
					UOC:AVY,A13,A14,A20,BVY,B20,HVY,H13,H14,H20,H21,H28,NNN	
22	PAOZZ	5310013124777	19207	12339397-5	NUT,PLAIN,BLIND RIV 5/16-18.....	3
					UOC:AVY,A13,A14,A20,BVY,B20,HVY,H13,H14,H20,H21,H28,NNN	
23	PAOZZ	5310000614650	96906	MS51943-31	NUT,SELF-LOCKING,HE 1/4-20.....	6
					UOC:AVY,A13,A14,A20,BVY,B20,HVY,H13,H14,H20,H21,H28,NNN	
24	PAOZZ	5340012551657	99017	W-5	CAP-PLUG,PROTECTIVE.....	6
					UOC:AVY,A13,A14,A20,BVY,B20,HVY,H13,H14,H20,H21,H28,NNN	
25	PAOZZ	5306012867182	34623	5588062	BOLT,SQUARE NECK 5/16-18 X 1.80....	3

SECTION II			TM9-2320-280-24P			
(1)	(2)	(3)	(4)	(5)	(6)	(7)
ITEM	SMR			PART		
NO	CODE	NSN	CAGEC	NUMBER	DESCRIPTION AND USABLE ON CODES(UC)	QTY
					UOC:AVY,A13,A14,A20,BVY,B20,HVY,H13, H14,H20,H21,H28,NNN	
26	PAOZZ	5305002253843	80204	B1821BH025C100N	SCREW,CAP,HEXAGON H 1/4-20 X 1.00..	2
27	PFOZZ	5365012101630	19207	12338892	SPACER,PLATE.....	2
28	PFOZZ	5340012097834	19207	12338906	COVER,ACCESS L.H.....	1
29	PAOZZ	5310002081918	24617	190254	NUT,SELF-LOCKING,HE.....	6
					UOC:AVY,A13,A14,A20,BVY,B20,HVY,H13, H14,H20,H21,H28,NNN	
30	PAOZZ	5310012175205	24617	9417714	WASHER,FLAT #10.....	6
					UOC:AVY,A13,A14,A20,BVY,B20,HVY,H13, H14,H20,H21,H28,NNN	
31	PAOZZ	5310000145850	96906	MS27183-42	WASHER,FLAT #10.....	6
					UOC:AVY,A13,A14,A20,BVY,B20,HVY,H13, H14,H20,H21,H28,NNN	
32	PAOZZ	5305009846213	96906	MS35206-266	SCREW,MACHINE #10-24 X 7/8.....	6
					UOC:AVY,A13,A14,A20,BVY,B20,HVY,H13, H14,H20,H21,H28,NNN	

END OF FIGURE

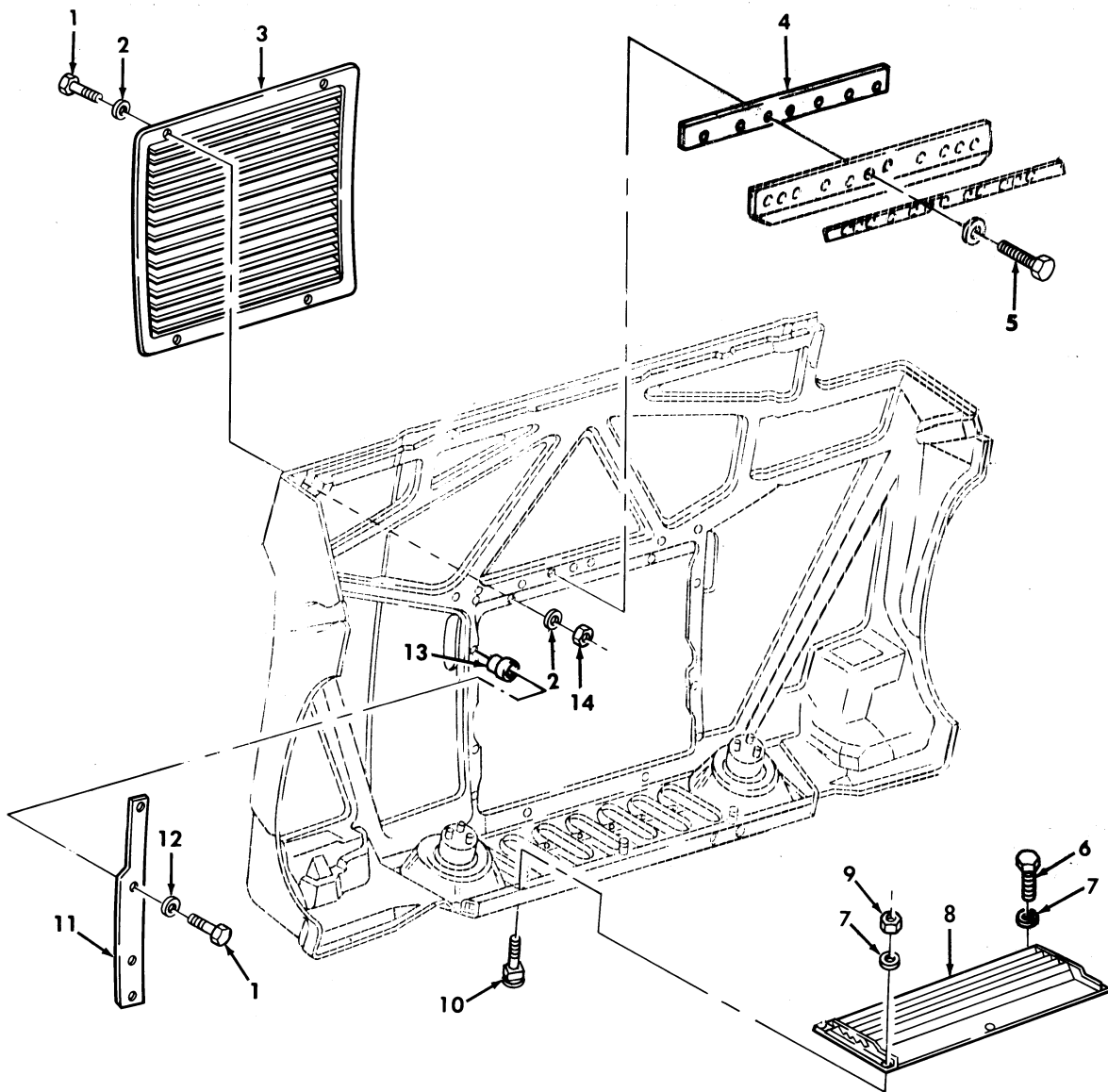

Figure 204. Hood Assembly Ballistic Grilles and Related Parts.

SECTION II			TM9-2320-280-24P			
(1)	(2)	(3)	(4)	(5)	(6)	(7)
ITEM	SMR			PART		
NO	CODE	NSN	CAGEC	NUMBER	DESCRIPTION AND USABLE ON CODES(UOC)	QTY
					GROUP 1801 BODY,CAB,HOOD,AND HULL ASSEMBLY	
					FIG. 204 HOOD ASSEMBLY BALLISTIC GRILLES AND RELATED PARTS	
1	PAOZZ	5305002253843	80204	B1821BH025C100N	SCREW,CAP,HEXAGON H 1/4-20 X 1.00.. UOC:A11,A15,A24,A25,A26,A27,B15,B16, B17,B18,B24,B25,C17,H11,H15,H16,H17, H18,H24,H25,H26,H27,MMM	4
2	PAOZZ	5310011023270	24617	2436161	WASHER,FLAT 1/4..... UOC:A11,A15,A24,A25,A26,A27,B15,B16, B17,B18,B24,B25,C17,H11,H15,H16,H17, H18,H24,H25,H26,H27,MMM	8
3	PAOZZ	2510011908458	19207	12338921	GRILLE,METAL BASIC ARMOR..... UOC:A11,A15,B15,B16,B17,B18,C17,H11, H15,H16,H17,H18,MMM	1
3	PAOZZ	2510011899730	19207	12338926	GRILLE,METAL HOOD,SUPPLEMENTAL ARMOR..... UOC:A24,A25,A26,A27,B24,B25,H24,H25, H26,H27	1
4	PAOZZ	5365011853108	19207	12338920-1	SPACER,PLATE CENTER,BASIC ARMOR.... UOC:A11,A15,B15,B16,B17,B18,C17,H11, H15,H16,H17,H18,MMM	4
4	PFOZZ	5365011899743	19207	12338920-2	SPACER,PLATE CENTER,SUPPLEMENTAL ARMOR..... UOC:A24,A25,A26,A27,B24,B25,H24,H25, H26,H27	1
5	PAOZZ	5305002253842	80204	B1821BH025C113N	SCREW,CAP,HEXAGON H 1/4-20 X 1.125. UOC:A11,A15,A24,A25,A26,A27,B15,B16, B17,B18,B24,B25,C17,H11,H15,H16,H17, H18,H24,H25,H26,H27,MMM	9
6	PAOZZ	5306002264827	80204	B1821BH031C100N	BOLT,MACHINE 5/16-18 X 1.00..... UOC:A11,A15,A24,A25,A26,A27,B15,B16, B17,B18,B24,B25,C17,H11,H15,H16,H17, H18,H24,H25,H26,H27,MMM	3
7	PAOZZ	5310000814219	96906	MS27183-12	WASHER,FLAT 3/8..... UOC:A11,A15,A24,A25,A26,A27,B15,B16, B17,B18,B24,B25,C17,H11,H15,H16,H17, H18,H24,H25,H26,H27,MMM	6
8	PFOZZ	2510011863311	19207	12338937	GRILLE,METAL FRONT,BASIC ARMOR..... UOC:A11,A15,B15,B16,B17,B18,C17,H11, H15,H16,H17,H18,MMM	1
8	PFOZZ	2510011910971	19207	12338936	GRILLE,RADIATOR,VEH FRONT, SUPPLEMENTAL ARMOR..... UOC:A24,A25,A26,A27,B24,B25,H24,H25, H26,H27	1
9	PAOZZ	5310009318167	96906	MS51967-6	NUT,PLAIN,HEXAGON 5/16-18..... UOC:A11,A15,A24,A25,A26,A27,B15,B16, B17,B18,B24,B25,C17,H11,H15,H16,H17, H18,H24,H25,H26,H27,MMM	3
10	PAOZZ	5306012867182	34623	5588062	BOLT,SQUARE NECK 5/16-18 X 1.8..... UOC:A11,A15,A24,A25,A26,A27,B15,B16,	3

SECTION II			TM9-2320-280-24P			
(1)	(2)	(3)	(4)	(5)	(6)	(7)
ITEM NO	SMR CODE	NSN	CAGEC	PART NUMBER	DESCRIPTION AND USABLE ON CODES(UC)	QTY
11	PFOZZ	2510011857945	34623	12338925-2	B17,B18,B24,B25,C17,H11,H15,H16,H17, H18,H24,H25,H26,H27,MMM SHIELD,HOOD,VEHICUL R.H.....	1
11	PFOZZ	2510011857950	34623	12338925-1	UOC:A11,A15,B15,B16,B17,B18,C17,H11, H15,H16,H17,H18,MMM SHIELD,HOOD,VEHICUL L.H.....	1
11	PAOZZ	2540011899729	34623	5579717	UOC:A11,A15,B15,B16,B17,B18,C17,H11, H15,H16,H17,H18,MMM ARMOR,SUPPLEMENTAL, HOOD,R.H., SUPPLEMENTAL ARMOR.....	1
11	PAOZZ	2510011899720	34623	5579716	UOC:A24,A25,A26,A27,B24,B25,H24,H25, H26,H27 SHIELD,BALLISTIC HO HOOD,L.H., SUPPLEMENTAL ARMOR.....	1
12	PAOZZ	5310008094058	96906	MS27183-10	UOC:A24,A25,A26,A27,B24,B25,H24,H25, H26,H27 WASHER,FLAT 1/4.....	6
13	PAOZZ	5340012134662	34623	5591957	UOC:A11,A15,A24,A25,A26,A27,B15,B16, B17,B18,B24,B25,C17,H11,H15,H16,H17, H18,H24,H25,H26,H27,MMM SHIELD,EXPANSION.....	6
14	PAOZZ	5310000614650	96906	MS51943-31	UOC:A11,A15,A24,A25,A26,A27,B15,B16, B17,B18,B24,B25,C17,H11,H15,H16,H17, H18,H24,H25,H26,H27,MMM NUT,SELF-LOCKING,HE 1/4-20.....	4

END OF FIGURE



12 — 13  
thru  
17

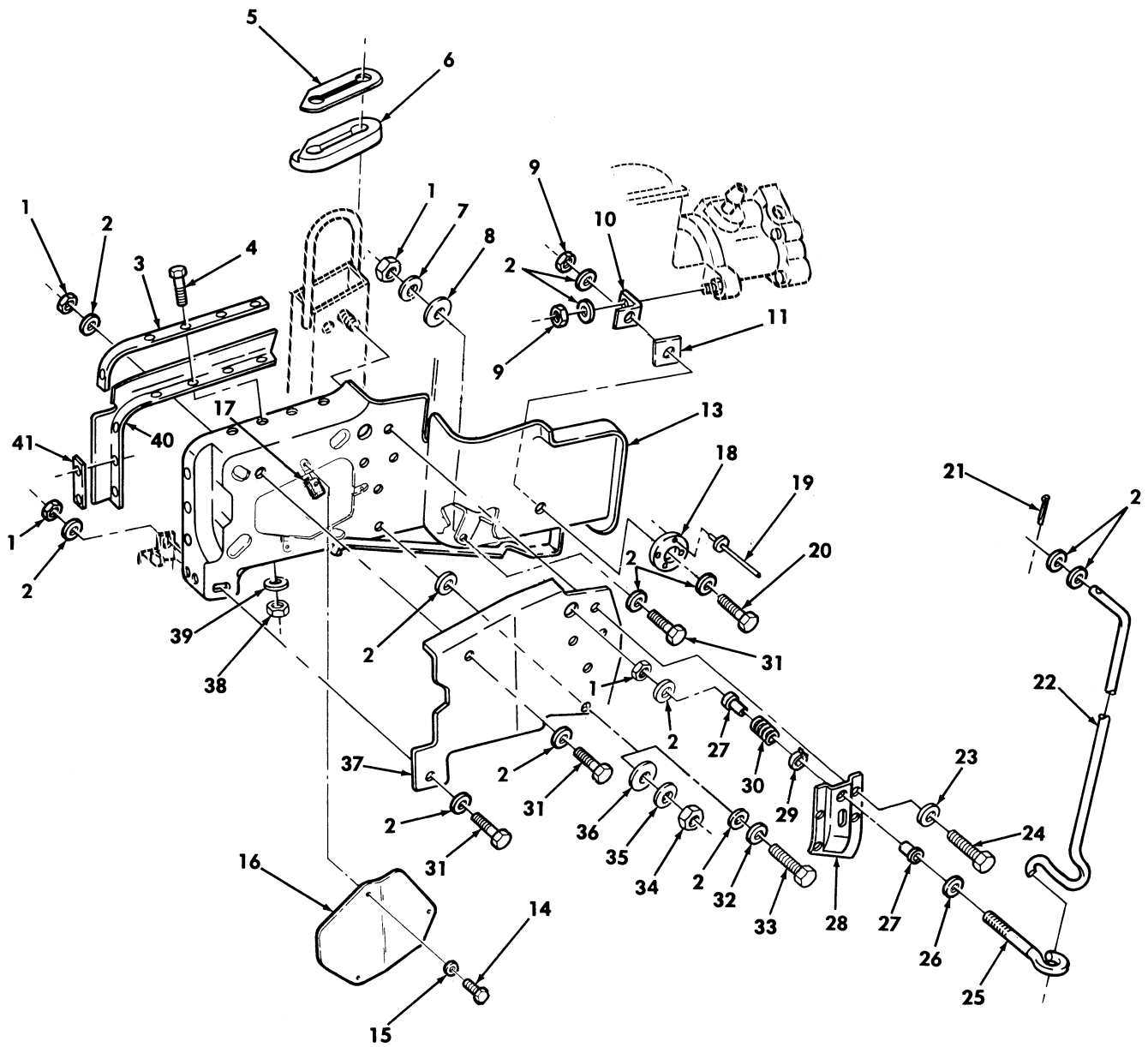

Figure 205. Left Hand Splash Shield, Radiator Side Armor, and Hood Prop Rod.

SECTION II			TM9-2320-280-24P			
(1)	(2)	(3)	(4)	(5)	(6)	(7)
ITEM NO	SMR CODE	NSN	CAGEC	PART NUMBER	DESCRIPTION AND USABLE ON CODES(UC)	QTY
					GROUP 1801 BODY,CAB,HOOD,AND HULL ASSEMBLY	
					FIG. 205 LEFT HAND SPLASH SHIELD, RADIATOR SIDE ARMOR,AND HOOD PROP ROD	
1	PAOZZ	5310008140673	96906	MS51943-33	NUT,SELF-LOCKING,HE 5/16-18.....	4
					UOC:A11,A15,A24,A25,A26,A27,B15,B16,B17,B18,B24,B25,C17,H11,H15,H16,H17,H18,H24,H25,H26,H27,MMM	
2	PAOZZ	5310000877493	96906	MS27183-13	WASHER,FLAT 3/8.....	13
					UOC:A11,A15,A24,A25,A26,A27,B16,B17,B18,H11,H15,H16,H17,H18,H24,H25,H26,H27,MMM	
2	PAOZZ	5310000877493	96906	MS27183-13	WASHER,FLAT 3/8.....	11
					UOC:BVY,B15,B20,B24,B25,C17,NNN	
3	PAOZZ	5340011850386	19207	12338630	STRAP,RETAINING UPPER.....	1
4	PAOZZ	5305002400194	96906	MS51849-76	SCREW,MACHINE #10-24 X 3/4.....	7
5	PAOZZ	5330013342834	19207	12342355	GASKET.....	1
6	PAOZZ	5330013405627	19207	12342357	SEAL,NONMETALLIC SP L.H.....	1
7	PAOZZ	5310012577719	34623	5593235	WASHER,FLAT 5/16.....	1
8	PAOZZ	5310012530060	34623	5593261	WASHER,FLAT 3/8.....	1
9	PAOZZ	5310009359021	96906	MS51943-35	NUT,SELF-LOCKING,HE 3/8-16.....	2
10	PFOZZ	5340012203084	19207	12338629	BRACKET,ANGLE.....	1
11	PAOZZ	5365012529214	34623	5591577-B	SPACER,PLATE.....	1
12	PAOZZ	2540011766521	34623	12446953	GUARD,SPLASH,VEHICU L.H.....	1
13	XAOZZ		19207	12446771	.GUARD,SPLASH,VEHICU.....	1
14	PAOZZ	5305001159934	96906	MS51849-55	.SCREW,MACHINE #8-32 X 5/8.....	3
15	PAOZZ	5310012134192	7X677	9423534	.WASHER,FLAT #8.....	3
16	PAOZZ	5340014570459	19207	12446770	.COVER,ACCESS.....	1
17	PAOZZ		24617	1494255	.RETAINER,ASSEMBLED #8-32.....	3
18	PAOZZ	5365012468281	19207	12338637	SUPPORT ASSEMBLY,B.....	1
19	PAOZZ	5320010338643	11815	CR3242-6-2	RIVET,BLIND 3/16 DIA.....	4
20	PAOZZ	5305007252317	80204	B1821BH038C150N	SCREW,CAP,HEXAGON H 3/8-16 X 1.50..	1
21	PAOZZ	5315008423044	14351	X601	PIN,COTTER 3/32 X 3/4.....	1
22	PFOZZ	2510011856118	19207	12338915	ROD,HOOD,VEHICULAR.....	1
23	PAOZZ	5310005825965	96906	MS35338-44	WASHER,LOCK 1/4.....	4
24	PAOZZ	5305005501537	34623	5593225	SCREW,TAPPING 1/4-28 X 1.00.....	4
25	PAOZZ	5306011867129	34623	5578418	BOLT,EYE.....	1
26	PAOZZ	5310012520512	34623	5592832	WASHER,FLAT 5/16.....	1
27	PAOZZ	3120011867715	19207	12338895	BUSHING,SLEEVE.....	2
28	PFOZZ	5340011867229	34623	5578414	STRAP,RETAINING.....	1
29	PAOZZ	5325002821830	96906	MS16624-1066	RING,RETAINING.....	1
30	PAOZZ	5360012559899	73821	C0850-081-2250-M	SPRING,HELICAL,COMP.....	1
31	PAOZZ	5306002258499	96906	MS90725-34	BOLT,MACHINE 5/16-18 X 1.00.....	3
32	PAOZZ	5310004079566	96906	MS35338-45	WASHER,LOCK 5/16.....	1
					UOC:AVY,A11,A13,A14,A15,A20,A24,A25,A26,A27,B15,B16,B17,B18,B20,B24,B25,C17,HVY,H11,H13,H14,H15,H16,H17,H18,H20,H24,MMM	
33	PAOZZ	5305012532993	34623	5593258	SCREW,TAPPING 5/16-18 X 1.00.....	1
					UOC:AVY,A11,A13,A14,A15,A20,A24,A25,	

SECTION II			TM9-2320-280-24P			
(1)	(2)	(3)	(4)	(5)	(6)	(7)
ITEM NO	SMR CODE	NSN	CAGEC	PART NUMBER	DESCRIPTION AND USABLE ON CODES(UC)	QTY
					A26,A27,B15,B16,B17,B18,B20,B24,B25,C17,HVY,H11,H13,H14,H15,H16,H17,H18,H20,H24,MMM	
34	PAOZZ	5310007610654	96906	MS51967-9	NUT,PLAIN,HEXAGON 3/8-16.....	2
					UOC:BVY,B15,B20,B24,B25,C17,NNN	
35	PAOZZ	5310006379541	96906	MS35338-46	WASHER,LOCK 3/8.....	2
					UOC:BVY,B15,B20,B24,B25,C17,NNN	
36	PAOZZ	5310000877493	96906	MS27183-13	WASHER,FLAT 3/8.....	2
					UOC:BVY,B15,B20,B24,B25,C17,NNN	
37	PFOZZ	2510011853107	34623	5578547	SHIELD,RADIATOR,VEH BASIC, L.H.....	1
					UOC:A11,A15,B15,B16,B17,B18,C17,H11,H15,H16,H17,H18,MMM	
37	PFOZZ	9515011899728	19207	12338640-2	ARMOR PLATE SUPPLEMENTAL, L.H.....	1
					UOC:A24,A25,A26,A27,B24,B25,H24,H25,H26,H27	
38	PAOZZ	5310002081918	88044	AN365-1024A	NUT,SELF-LOCKING,HE #10-24.....	7
39	PAOZZ	5310000145850	96906	MS27183-42	WASHER,FLAT #10.....	7
40	PAOZZ	5330011858715	34623	5593910	SEAL,NONMETALLIC SP L.H.....	1
41	PAOZZ	5340011865520	19207	12338634-1	PLATE,MENDING LOWER.....	1

END OF FIGURE

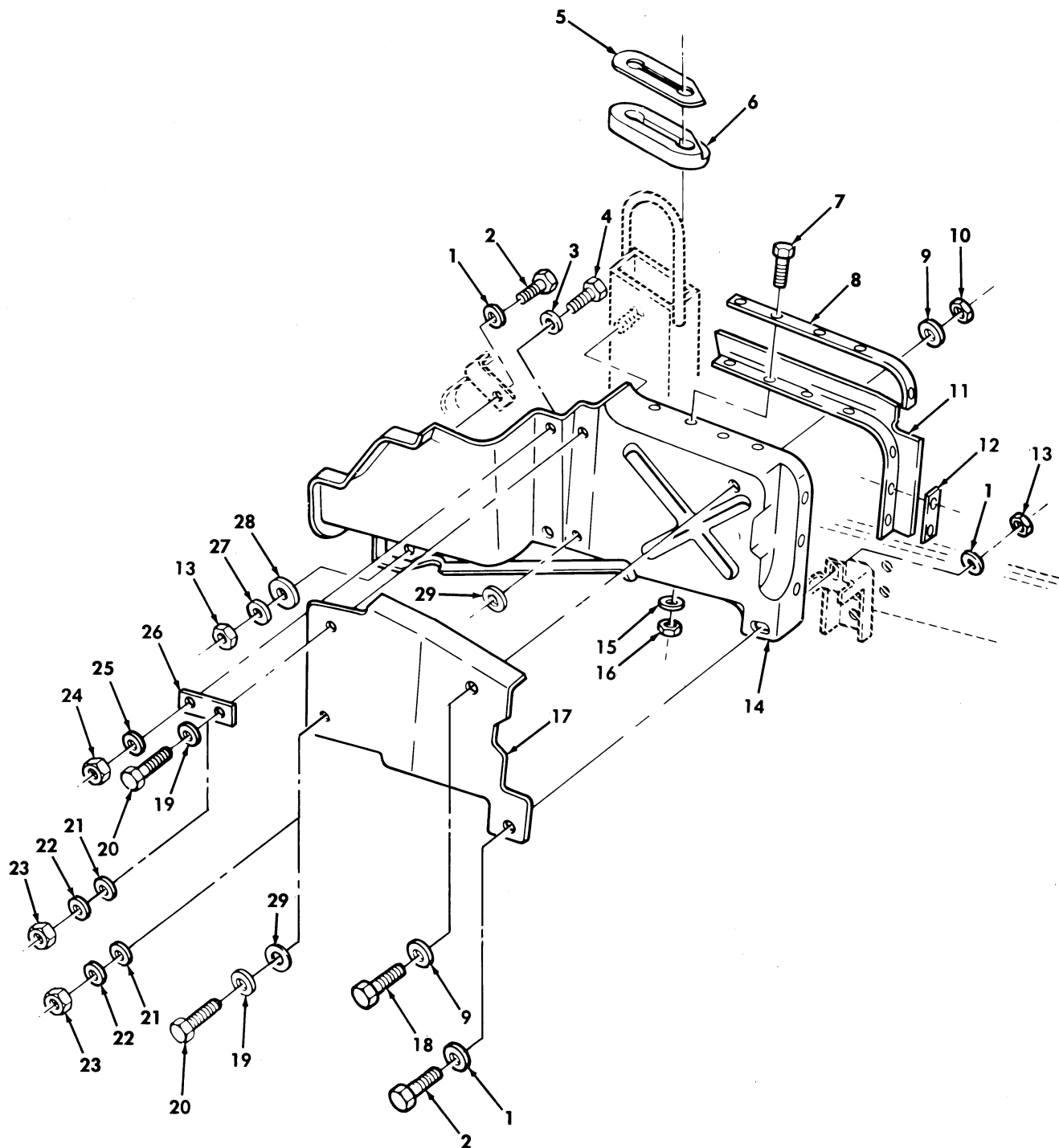
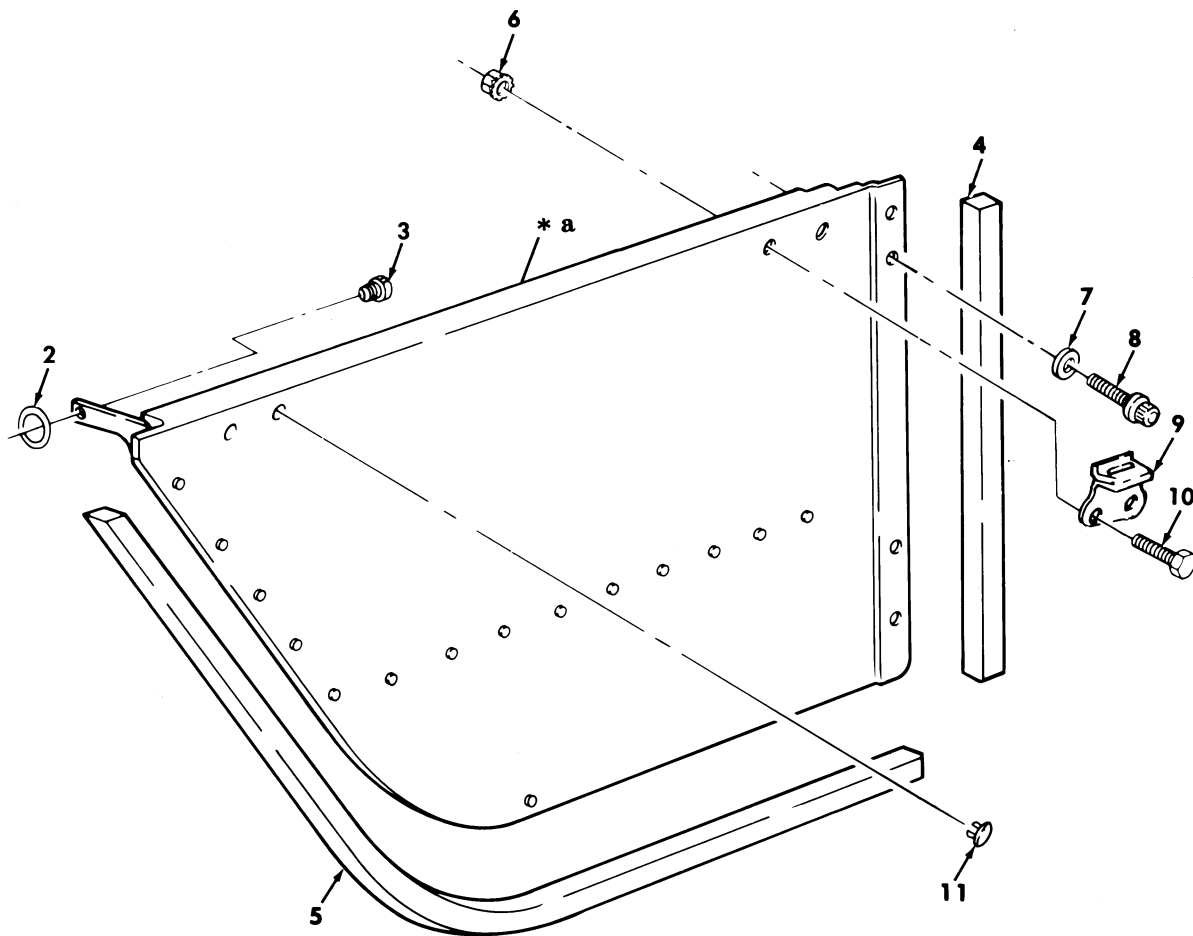
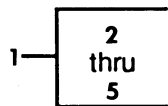

Figure 206. Right Hand Splash Shield and Radiator Side Armor.

SECTION II		TM9-2320-280-24P				
(1)	(2)	(3)	(4)	(5)	(6)	(7)
ITEM NO	SMR CODE	NSN	CAGEC	PART NUMBER	DESCRIPTION AND USABLE ON CODES(UC)	QTY
					GROUP 1801 BODY,CAB,HOOD,AND HULL ASSEMBLY	
					FIG. 206 RIGHT HAND SPLASH SHIELD AND RADIATOR SIDE ARMOR	
1	PAOZZ	5310000877493	96906	MS27183-13	WASHER,FLAT 3/8.....	3
2	PAOZZ	5306002258499	96906	MS90725-34	BOLT,MACHINE 5/16-18 X 1.00.....	2
3	PAOZZ	5310008093078	96906	MS27183-11	WASHER,FLAT 1/4.....	1
4	PAOZZ	5305000680502	96906	MS90725-6	SCREW,CAP,HEXAGON H 1/4-20 X 3/4...	1
5	PAOZZ	5330013342834	19207	12342355	GASKET.....	1
6	PAOZZ	5330013418963	19207	12342358	SEAL,NONMETALLIC SP R.H.....	1
7	PAOZZ	5305002400194	96906	MS51849-76	SCREW,MACHINE #10-24 X 3/4.....	7
8	PAOZZ	5340011850386	19207	12338630	STRAP,RETAINING.....	1
9	PAOZZ	5310000877493	96906	MS27183-13	WASHER,FLAT 3/8.....	2
					UOC:A11,A15,A24,A25,A26,A27,B15,B16,B17,B18,B24,B25,C17,H11,H15,H16,H17,H18,H24,H25,H26,H27,MMM	
10	PAOZZ	5310008140673	96906	MS51943-33	NUT,SELF-LOCKING,HE 5/16-18.....	1
					UOC:A11,A15,A24,A25,A26,A27,B15,B16,B17,B18,B24,B25,C17,H11,H15,H16,H17,H18,H24,H25,H26,H27,MMM	
11	PAOZZ	5330011858714	34623	5593912	SEAL,NONMETALLIC SP R.H.....	1
12	PAOZZ	5340011913359	34623	5582605	CLAMP,LOOP.....	1
13	PAOZZ	5310008140673	96906	MS51943-33	NUT,SELF-LOCKING,HE 5/16-18.....	2
14	PAOZZ	2540011747696	19207	12340360	GUARD,SPLASH,VEHICU R.H.....	1
15	PAOZZ	5310000145850	96906	MS27183-42	WASHER,FLAT #10.....	7
16	PAOZZ	5310002081918	88044	AN365-1024A	NUT,SELF-LOCKING,HE #10-24.....	7
17	PFOZZ	2510011857946	34623	12338639-1	SHIELD,RADIATOR,VEH BASIC,R.H.....	1
					UOC:A11,A15,B15,B16,B17,B18,C17,H11,H15,H16,H17,H18,MMM	
17	PBOZZ	2510011899744	34623	5578551	PLATE,ARMOR,RADIATO SUPPLEMENTAL,R.H.....	1
					UOC:A24,A25,A26,A27,B24,B25,H24,H25,H26,H27	
18	PAOZZ	5306002258499	96906	MS90725-34	BOLT,MACHINE 5/16-18 X 1.00.....	1
					UOC:A11,A15,A24,A25,A26,A27,B15,B16,B17,B18,B24,B25,C17,H11,H15,H16,H17,H18,H24,H25,H26,H27,MMM	
19	PAOZZ	5310004079566	96906	MS35338-45	WASHER,LOCK 5/16.....	2
					UOC:AVY,A11,A13,A14,A15,A20,A24,A25,A26,A27,B16,B17,B18,HVY,H11,H13,H14,H15,H16,H17,H18,H20,H21,H24,H25,H26,H27,H28,MMM	
20	PAOZZ	5305012532993	34623	5593258	SCREW,TAPPING 5/16-18 X 1.00.....	2
					UOC:AVY,A11,A13,A14,A15,A20,A24,A25,A26,A27,B16,B17,B18,HVY,H11,H13,H14,H15,H16,H17,H18,H20,H21,H24,H25,H26,H27,H28,MMM	
21	PAOZZ	5310000877493	81337	5-11-966-41	WASHER,FLAT 3/8.....	2
					UOC:BVY,B15,B20,B24,B25,C17,NNN	
22	PAOZZ	5310006379541	65035	P49866-11	WASHER,LOCK.....	2
					UOC:BVY,B15,B20,B24,B25,C17,NNN	

SECTION II			TM9-2320-280-24P			
(1)	(2)	(3)	(4)	(5)	(6)	(7)
ITEM	SMR			PART		
NO	CODE	NSN	CAGEC	NUMBER	DESCRIPTION AND USABLE ON CODES(UC)	QTY
23	PAOZZ	5310007610654	96906	MS51967-9	NUT,PLAIN,HEXAGON 3/8-16.....	2
					UOC:BVY,B15,B20,B24,B25,C17,NNN	
24	PAOZZ	5310000614650	96906	MS51943-31	NUT,SELF-LOCKING,HE 1/4-20.....	1
25	PAOZZ	5310008094058	96906	MS27183-10	WASHER,FLAT 1/4.....	1
26	PAOZZ	5365012101584	19207	12338635	SPACER,SLEEVE.....	1
27	PAOZZ	5310012577719	34623	5593235	WASHER,FLAT 5/16.....	1
28	PAOZZ	5310012530060	34623	5593261	WASHER,FLAT 3/8.....	1
29	PAOZZ	5310000877493	96906	MS27183-13	WASHER,FLAT 3/8.....	2
					UOC:A11,A15,A24,A25,A26,A27,B15,B16, B17,B18,B24,B25,C17,H11,H15,H16,H17, H18,H24,H25,H26,H27,MMM	

END OF FIGURE



\* a PART OF ITEM 1

Figure 207. Rear Fixed Doors and Mounting Hardware.

SECTION II			TM9-2320-280-24P			
(1)	(2)	(3)	(4)	(5)	(6)	(7)
ITEM NO	SMR CODE	NSN	CAGEC	PART NUMBER	DESCRIPTION AND USABLE ON CODES(UC)	QTY
					GROUP 1801 BODY,CAB,HOOD,AND HULL ASSEMBLY	
					FIG. 207 REAR FIXED DOORS AND MOUNTING HARDWARE	
1	PFOOO	2510011931807	34623	12340028-5	DOOR,METAL,SWINGING L.H..... UC:AVY,A13,A14,BVY,HVY,H13,H14,H21,H28,NNN	1
1	PAOOO	2510011899717	34623	12340028-2L	DOOR,METAL,SWINGING R.H..... UC:AVY,A13,A14,BVY,HVY,H13,H14,H21,H28,NNN	1
2	PAOZZ	5325012668414	72794	GH7	.EYELET,TURNLOCK FAS..... UC:AVY,A13,A14,BVY,HVY,H13,H14,H21,H28,NNN	1
3	PAOZZ	5325012641522	72794	AJ7-40-CBC	.STUD,TURNLOCK FASTE..... UC:AVY,A13,A14,BVY,HVY,H13,H14,H21,H28,NNN	1
4	MOOZZ		34623	5584836	.SEAL MAKE FROM GASKET,P/N R-451-N, 22 INCHES LONG..... UC:AVY,A13,A14,BVY,HVY,H13,H14,H21,H28,NNN	1
5	MOOZZ		34623	5584813	.SEAL MAKE FROM GASKET,P/N R-451-N, 50 INCHES LONG..... UC:AVY,A13,A14,BVY,HVY,H13,H14,H21,H28,NNN	1
6	PAOZZ	5310001249265	24617	271169	NUT,PLAIN,ASSEMBLED #10-32..... UC:A13,A14,H13,H14	8
7	PAOZZ	5310008094058	96906	MS27183-10	WASHER,FLAT 1/4..... UC:AVY,A13,A14,BVY,HVY,H13,H14,H21,H28,NNN	8
8	PAOZZ	5306013235535	19207	12340352-1	BOLT,MACHINE 1/4-20 X 3/4..... UC:AVY,A13,A14,BVY,HVY,H13,H14,H21,H28,NNN	8
9	PAOZZ	5340012609027	34623	5593625	LOOP,STRAP FASTENER..... UC:A13,A14,H13,H14	4
10	PAOZZ	5305009897435	96906	MS35207-264	SCREW,MACHINE #10-32 X .62..... UC:A13,A14,H13,H14	8
11	PAOZZ	5325001850961	19207	12340533-3	FASTENER..... UC:AVY,BVY,HVY,H21,H28,NNN	8

END OF FIGURE



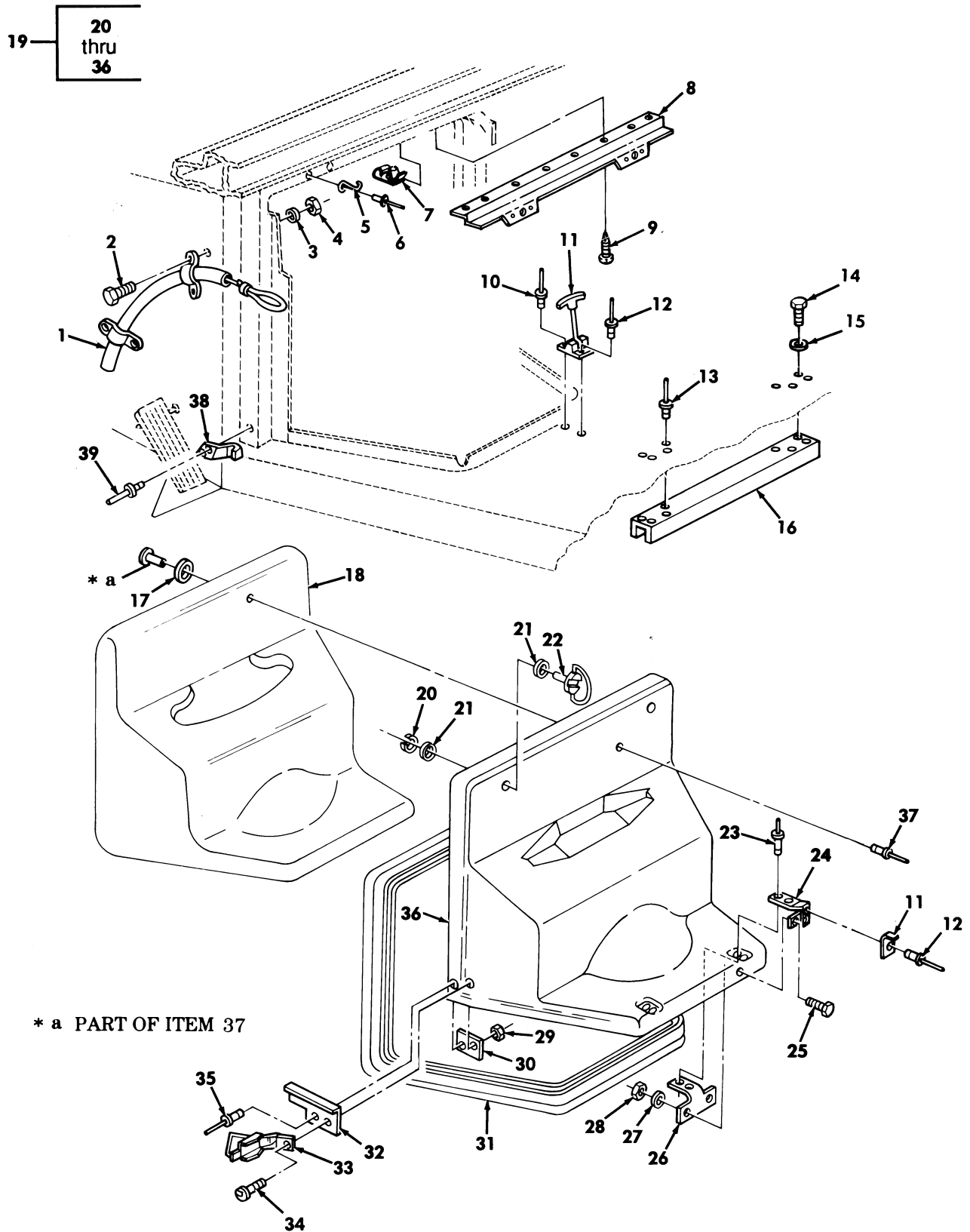

Figure 208. Engine Access Cover Assembly, "A" Pillar Insulation, and Steering Wheel Lock.

SECTION II			TM9-2320-280-24P			
(1)	(2)	(3)	(4)	(5)	(6)	(7)
ITEM NO	SMR CODE	NSN	CAGEC	PART NUMBER	DESCRIPTION AND USABLE ON CODES(UOC)	QTY
GROUP 1801 BODY,CAB,HOOD,AND HULL ASSEMBLY						
FIG. 208 ENGINE ACCESS COVER ASSEMBLY,"A" PILLAR INSULATION,AND STEERING WHEEL LOCK						
1	PFOZZ	2530011964724	19207	12340252	LOCK ASSEMBLY,STEER.....	1
2	PAOZZ	5305000680508	80204	B1821BH025C075N	SCREW,CAP,HEXAGON H 1/4-20 X .75...	4
3	PAOZZ	5310012545352	34623	5593308	WASHER,FLAT 1/4.....	4
4	PAOZZ	5310014326727	24617	9419471	NUT,SELF-LOCKING,HE 1/4-20.....	4
5	PAOZZ	5325004493001	72794	S7-250	LOCKSPRING,TURNLOCK.....	2
6	PAOZZ	5320000835009	11078	ADS43	RIVET,BLIND 1/8 DIA.....	4
7	PAOZZ	5310011947066	72800	C7685-10A	NUT,SHEET SPRING.....	8
8	PAOZZ	5340013327515	19207	12338853	BRACKET,MOUNTING.....	1
9	PAOZZ	5305004324205	96906	MS51861-49	SCREW,TAPPING 190-16 X 1.00.....	8
10	PAOZZ	5320012200596	11815	CR-213-4-4	RIVET,BLIND 1/8 DIA.....	2
11	PAOZZ	5340004922313	94222	37-10-071-10	CATCH,CLAMPING.....	2
12	PAOZZ	5320012582576	11815	CR-213-4-2	RIVET,BLIND 1/8 DIA.....	4
13	PAOZZ	5320011435075	80205	NAS9301BNS-6-02	RIVET,BLIND 3/16.....	2
14	PAOZZ	5305000680502	96906	MS90725-6	SCREW,CAP,HEXAGON H 1/4-20 X 3/4...	4
15	PAOZZ	5310012510748	34623	5593691	WASHER,FLAT 1/4.....	4
16	PFOZZ	2540012028547	19207	12340638	BRACE,RADIO RACK.....	1
17	PFOZZ	5310012605784	34623	5597048	WASHER,RECESSED.....	7
18	PAOZZ	2510012541484	34623	12340658	INSULATION,COVER,E.....	1
19	PAOZZ	2510012481340	19207	12339431	HOOD,ENGINE COMPART.....	1
20	PAOZZ	5325012668414	72794	GH7	.EYELET,TURNLOCK FAS.....	2
21	PAOZZ	5310012789555	34623	5593318	.WASHER,FLAT 7/16.....	4
22	PAOZZ	5325011917555	72794	BJR7-1.00	.STUD,TURNLOCK FASTE.....	2
23	PAOZZ	5320010338637	11815	CR3243-6-4	.RIVET,BLIND 3/16 DIA.....	4
24	PFOZZ	5340012528537	34623	5585132-C	.STRAP,RETAINING.....	2
25	PAOZZ	5305010062053	96906	MS51849-75	.SCREW,MACHINE #10-24 X 9/16.....	4
26	PFOZZ	5340012554655	34623	5585133	.BRACKET,ANGLE #10.....	2
27	PAOZZ	5310012531618	96906	MS51412-18	.WASHER,FLAT #10.....	4
28	PAOZZ	5310009349758	96906	MS35649-202	.NUT,PLAIN,HEXAGON #10-24.....	4
29	PAOZZ	5310008140673	96906	MS51943-33	.NUT,SELF-LOCKING,HE 5/16-18.....	2
30	PFOZZ	5365012528026	34623	5585143	.SPACER,PLATE.....	2
31	PAOZZ	5330011973620	34623	SF5575925	.SEAL ASSEMBLY.....	1
32	PFOZZ	5342012493502	34623	12338952-1	.BRACKET,ENGINE ACCE L.H.....	1
32	PFOZZ	5342012485389	34623	12338952-2	.BRACKET,ENGINE ACCE R.H.....	1
33	PAOZZ	2540012102787	19207	12338950	.LATCH,HOOD,VEHICULA.....	2
34	PAOZZ	5305012111470	19207	12339428	.SCREW,SHOULDER 5/16-18 X 1.00.....	2
35	PAOZZ	5320010339126	11815	CR3242-6-4	.RIVET,BLIND 3/16.....	2
36	XAOZZ		34623	5593982	.COVER.....	1
37	PAOZZ	5320012542283	11815	BALM-6BP-14	RIVET 3/16 DIA.....	7
38	PFOZZ	2540012477914	19207	12338945-2	STRIKE,ENGINE COVER R.H.....	1
38	PFOZZ	2540012477915	19207	12338945-1	STRIKE,ENGINE COVER L.H.....	1
39	PAOZZ	5320010338638	11815	CR3243-6-3	RIVET,BLIND 3/16 DIA.....	4

END OF FIGURE

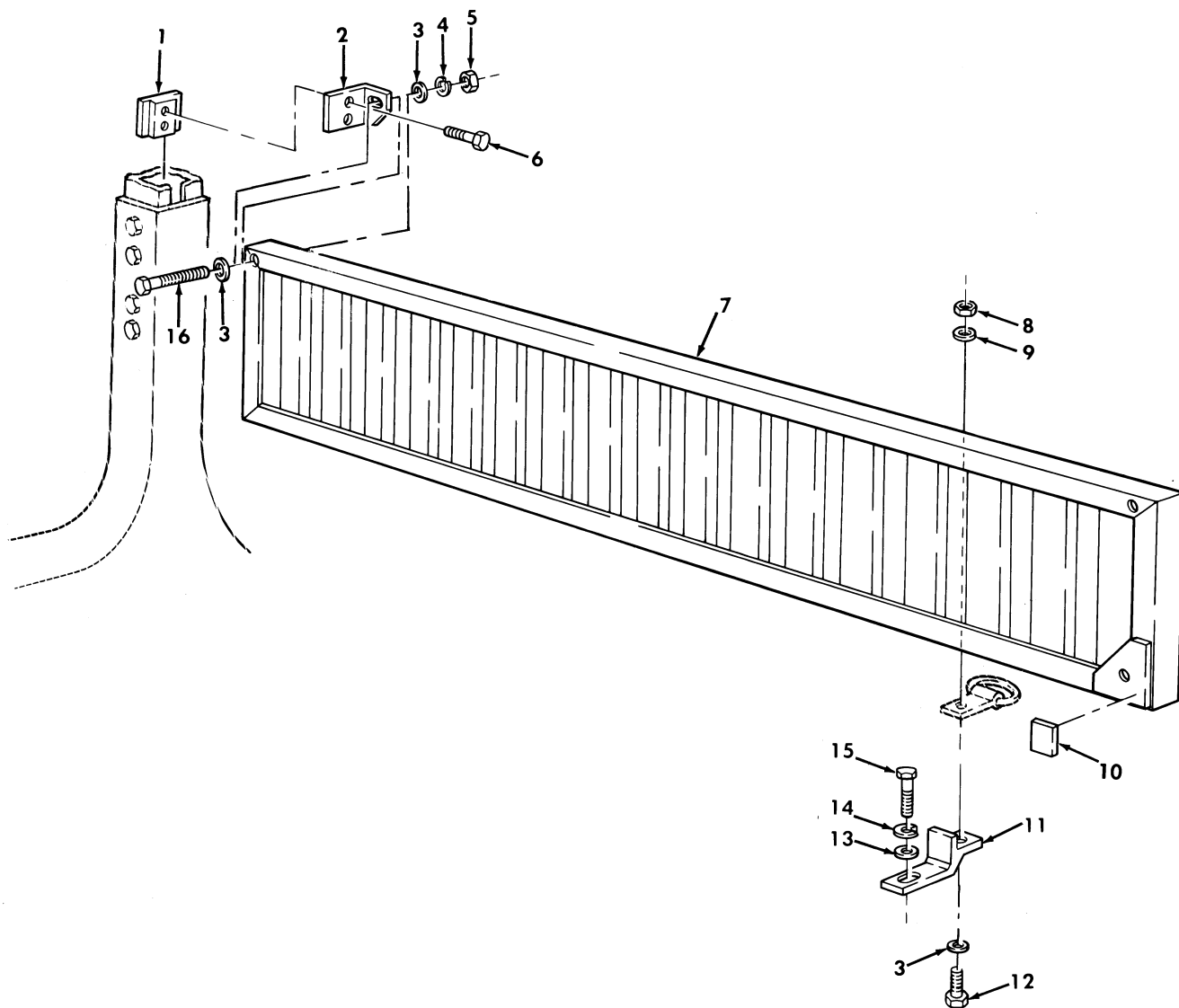

Figure 209. Cargo Bulkhead and Mounting Hardware.

SECTION II			TM9-2320-280-24P			
(1)	(2)	(3)	(4)	(5)	(6)	(7)
ITEM NO	SMR CODE	NSN	CAGEC	PART NUMBER	DESCRIPTION AND USABLE ON CODES(UC)	QTY
					GROUP 1801 BODY,CAB,HOOD,AND HULL ASSEMBLY	
					FIG. 209 CARGO BULKHEAD AND MOUNTING HARDWARE	
1	PAOZZ	5310011971161	34623	5575466	NUT,PLAIN,PLATE 1/4-20,GREEN, (PAINT TAN OR WHITE IF REQUIRED) PART OF KIT P/N 12338119 PART OF KIT P/N 57K0221 PART OF KIT P/N 57K0217 UC:AVY,A13,A14,BVY,HPM,HVY,H13,H14, KTV,NNN	2
2	PFOZZ	5340012033273	19207	12340709-1	BRACKET,ANGLE L.H.,GREEN,(PAINT TAN OR WHITE IF REQUIRED) PART OF KIT P/N 12338119 PART OF KIT P/N 57K0221 PART OF KIT P/N 57K0217..... UC:AVY,A13,A14,BVY,HPM,HVY,H13,H14, KTV,NNN	1
2	PFOZZ	5340012055118	19207	12340709-2	BRACKET,ANGLE R.H.,GREEN,(PAINT TAN OR WHITE IF REQUIRED) PART OF KIT P/N 12338119 PART OF KIT P/N 57K0221 PART OF KIT P/N 57K0217..... UC:AVY,A13,A14,BVY,HPM,HVY,H13,H14, KTV,NNN	1
3	PAOZZ	5310000814219	96906	MS27183-12	WASHER,FLAT 5/16,GREEN,(PAINT TAN OR WHITE IF REQUIRED) PART OF KIT P/N 12338119 PART OF KIT P/N 57K0221 PART OF KIT P/N 57K0217..... UC:AVY,A13,A14,BVY,HPM,HVY,H13,H14, KTV,NNN	6
4	PAOZZ	5310011993440	7X677	9424258	WASHER,LOCK 5/16,GREEN,(PAINT TAN OR WHITE IF REQUIRED) PART OF KIT P/N 12338119 PART OF KIT P/N 57K0221 PART OF KIT P/N 57K0217..... UC:AVY,A13,A14,BVY,HPM,HVY,H13,H14, KTV,NNN	2
5	PAOZZ	5310008807744	96906	MS51967-5	NUT,PLAIN,HEXAGON 5/16-18,GREEN, (PAINT TAN OR WHITE IF REQUIRED) PART OF KIT P/N 12338119 PART OF KIT P/N 57K0221 PART OF KIT P/N 57K0217 UC:AVY,A13,A14,BVY,HPM,HVY,H13,H14, KTV,NNN	2
6	PAOZZ	5305000712505	80204	B1821BH025C088N	SCREW,CAP,HEXAGON H 1/4-20 X 7/8, GREEN,(PAINT TAN OR WHITE IF REQUIRED) PART OF KIT P/N 12338119 PART OF KIT P/N 57K0221 PART OF KIT P/N 57K0217..... UC:AVY,A13,A14,BVY,HPM,HVY,H13,H14, KTV,NNN	4
7	PFOZZ	2510011893456	19207	12339697	CARGO BULKHEAD ASSE GREEN,(PAINT TAN OR WHITE IF REQUIRED) PART OF KIT P/N 12338119 PART OF KIT P/N 57K0221 PART OF KIT P/N 57K0217.....	1

SECTION II			TM9-2320-280-24P			
(1)	(2)	(3)	(4)	(5)	(6)	(7)
ITEM NO	SMR CODE	NSN	CAGEC	PART NUMBER	DESCRIPTION AND USABLE ON CODES(UOC)	QTY
8	PAOZZ	5310008140673	96906	MS51943-33	UOC:AVY,A13,A14,BVY,HPM,HVY,H13,H14, KTV,NNN NUT,SELF-LOCKING,HE 5/16-18,GREEN, (PAINT TAN OR WHITE IF REQUIRED) PART OF KIT P/N 12338119 PART OF KIT P/N 57K0221 PART OF KIT P/N 57K0217 UOC:AVY,A13,A14,BVY,HPM,HVY,H13,H14, KTV,NNN	2
9	PAOZZ	5310011191024	24617	2436162	WASHER,FLAT 5/16,GREEN,(PAINT TAN OR WHITE IF REQUIRED) PART OF KIT P/N 12338119 PART OF KIT P/N 57K0221 PART OF KIT P/N 57K0217..... UOC:AVY,A13,A14,BVY,HPM,HVY,H13,H14, KTV,NNN	2
10	MOOZZ		19207	12340721-1.25	RUBBER STRIP MAKE FROM RUBBER,P/N 12340721,1.25 INCHES LONG PART OF KIT P/N 12338119 PART OF KIT P/N 57K0221 PART OF KIT P/N 57K0217..... UOC:AVY,A13,A14,BVY,HPM,HVY,H13,H14, KTV,NNN	7
11	PFOZZ	5342011965312	19207	12340720	SUPPORT,PILLAR VEHI GREEN,(PAINT TAN OR WHITE IF REQUIRED) PART OF KIT P/N 12338119 PART OF KIT P/N 57K0221 PART OF KIT P/N 57K0217..... UOC:AVY,A13,A14,BVY,HPM,HVY,H13,H14, KTV,NNN	2
12	PAOZZ	5306010758519	96906	MS90725-36	BOLT,MACHINE 5/16-18 X 1.00,GREEN, (PAINT TAN OR WHITE IF REQUIRED) PART OF KIT P/N 12338119 PART OF KIT P/N 57K0221 PART OF KIT P/N 57K0217 UOC:AVY,A13,A14,BVY,HPM,HVY,H13,H14, KTV,NNN	2
13	PAOZZ	5310008095997	96906	MS27183-17	WASHER,FLAT 1/2,GREEN,(PAINT TAN OR WHITE IF REQUIRED) PART OF KIT P/N 12338119 PART OF KIT P/N 57K0221 PART OF KIT P/N 57K0217..... UOC:AVY,A13,A14,BVY,HPM,HVY,H13,H14, KTV,NNN	2
14	PAOZZ	5310012167390	96906	MS51415-9	WASHER,LOCK 1/2,GREEN,(PAINT TAN OR WHITE IF REQUIRED) PART OF KIT P/N 12338119 PART OF KIT P/N 57K0221 PART OF KIT P/N 57K0217..... UOC:AVY,A13,A14,BVY,HPM,HVY,H13,H14, KTV,NNN	2
15	PAOZZ	5305000712069	80204	B1821BH050C150N	SCREW,CAP,HEXAGON H 1/2-13 X 1.50, GREEN,(PAINT TAN OR WHITE IF REQUIRED) PART OF KIT P/N 12338119 PART OF KIT P/N 57K0221 PART OF KIT P/N 57K0217..... UOC:AVY,A13,A14,BVY,HPM,HVY,H13,H14, KTV,NNN	2
16	PAOZZ	5306002264835	80204	B1821BH031C250N	BOLT,MACHINE 5/16-18 X 2.50,GREEN, (PAINT TAN OR WHITE IF REQUIRED)....	2

SECTION II			TM9-2320-280-24P			
(1)	(2)	(3)	(4)	(5)	(6)	(7)
ITEM	SMR			PART		
NO	CODE	NSN	CAGEC	NUMBER	DESCRIPTION AND USABLE ON CODES(UOC)	QTY
KIT PDOZZ	2510012468287	19207	12338119		UOC:AVY,A13,A14,BVY,HPM,HVY,H13,H14, KTV,NNN PANEL,BODY,VEHICULA GREEN.....	1
					UOC:AVY,A13,A14,BVY,HPM,HVY,H13,H14, KTV,NNN	
					BOLT,MACHINE ( 2) 209-12	
					BRACKET,ANGLE ( 1) 209-2	
					BRACKET,ANGLE ( 1) 209-2	
					CARGO BULKHEAD ASSE( 1) 209-7	
					NUT,PLAIN,HEXAGON ( 2) 209-5	
					NUT,PLAIN,PLATE ( 2) 209-1	
					NUT,SELF-LOCKING,HE( 2) 209-8	
					RUBBER STRIP ( 7) 209-10	
					SCREW,CAP,HEXAGON H( 4) 209-6	
					SCREW,CAP,HEXAGON H( 2) 209-15	
					SUPPORT,PILLAR VEHI( 2) 209-11	
					WASHER,FLAT ( 6) 209-3	
					WASHER,FLAT ( 2) 209-9	
					WASHER,FLAT ( 2) 209-13	
					WASHER,LOCK ( 2) 209-4	
					WASHER,LOCK ( 2) 209-14	
KIT PAOZZ	2510013388087	19207	57K0217		PANEL,BODY,VEHICULA TAN.....	1
					UOC:AVY,A13,A14,BVY,HPM,HVY,H13,H14, KTV,NNN	
					BOLT,MACHINE ( 2) 209-12	
					BRACKET,ANGLE ( 1) 209-2	
					BRACKET,ANGLE ( 1) 209-2	
					CARGO BULKHEAD ASSE( 1) 209-7	
					NUT,PLAIN,HEXAGON ( 2) 209-5	
					NUT,PLAIN,PLATE ( 2) 209-1	
					NUT,SELF-LOCKING,HE( 2) 209-8	
					RUBBER STRIP ( 7) 209-10	
					SCREW,CAP,HEXAGON H( 4) 209-6	
					SCREW,CAP,HEXAGON H( 2) 209-15	
					SUPPORT,PILLAR VEHI( 2) 209-11	
					WASHER,FLAT ( 6) 209-3	
					WASHER,FLAT ( 2) 209-9	
					WASHER,FLAT ( 2) 209-13	
					WASHER,LOCK ( 2) 209-4	
					WASHER,LOCK ( 2) 209-14	
KIT PDOZZ	2540013917845	19207	57K0221		COVER,FITTED,VEHICU WHITE.....	1
					UOC:AVY,A13,A14,BVY,HPM,HVY,H13,H14, KTV,NNN	
					BOLT,MACHINE ( 2) 209-12	
					BRACKET,ANGLE ( 1) 209-2	
					BRACKET,ANGLE ( 1) 209-2	
					CARGO BULKHEAD ASSE( 1) 209-7	
					NUT,PLAIN,HEXAGON ( 2) 209-5	
					NUT,PLAIN,PLATE ( 2) 209-1	
					NUT,SELF-LOCKING,HE( 2) 209-8	
					RUBBER STRIP ( 7) 209-10	
					SCREW,CAP,HEXAGON H( 4) 209-6	
					SCREW,CAP,HEXAGON H( 2) 209-15	

SECTION II			TM9-2320-280-24P			
(1)	(2)	(3)	(4)	(5)	(6)	(7)
ITEM	SMR			PART		
NO	CODE	NSN	CAGEC	NUMBER	DESCRIPTION AND USABLE ON	CODES (UOC) QTY
					SUPPORT, PILLAR VEHI	( 2) 209-11
					WASHER, FLAT	( 6) 209-3
					WASHER, FLAT	( 2) 209-9
					WASHER, FLAT	( 2) 209-13
					WASHER, LOCK	( 2) 209-4
					WASHER, LOCK	( 2) 209-14

END OF FIGURE

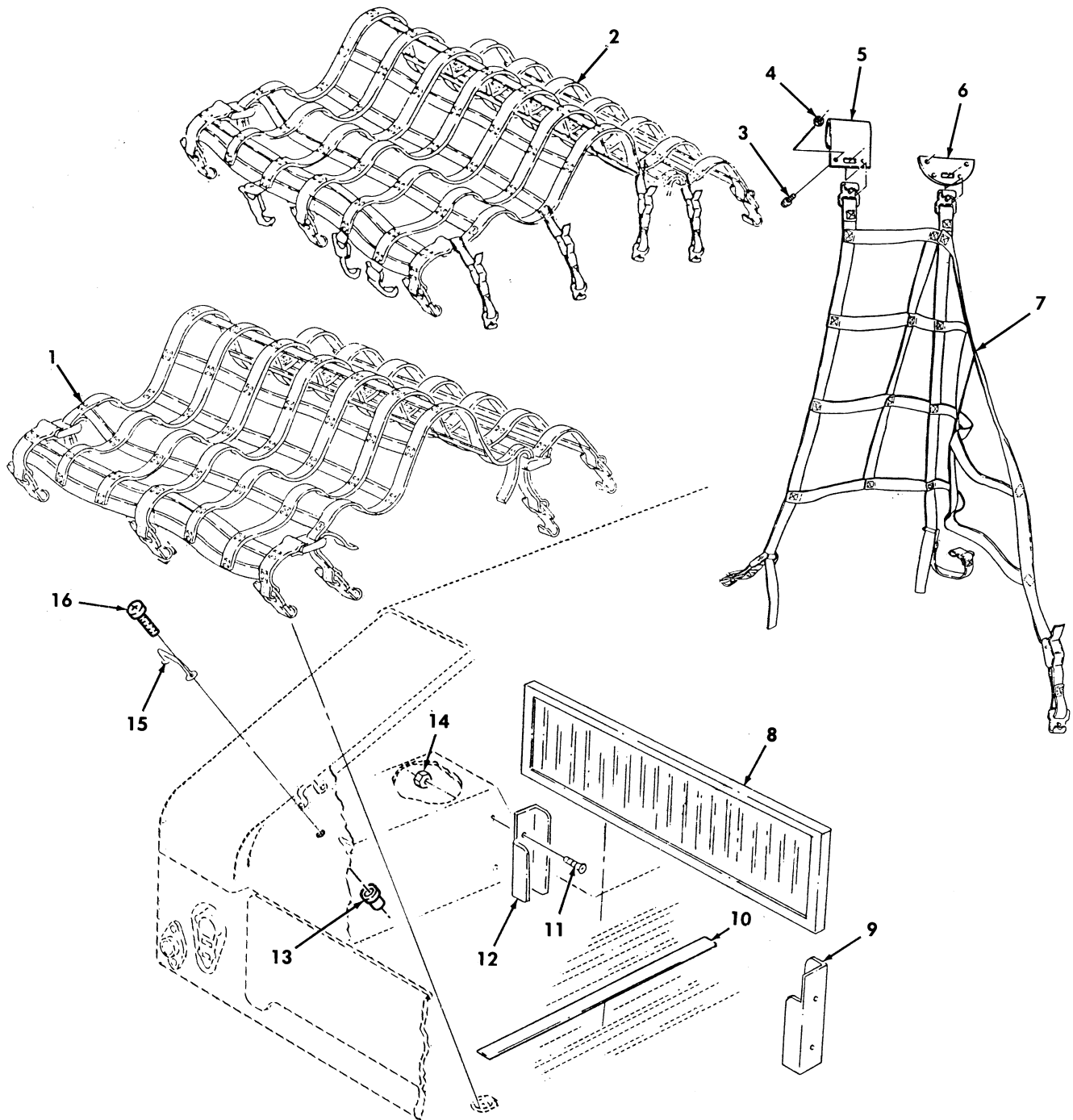
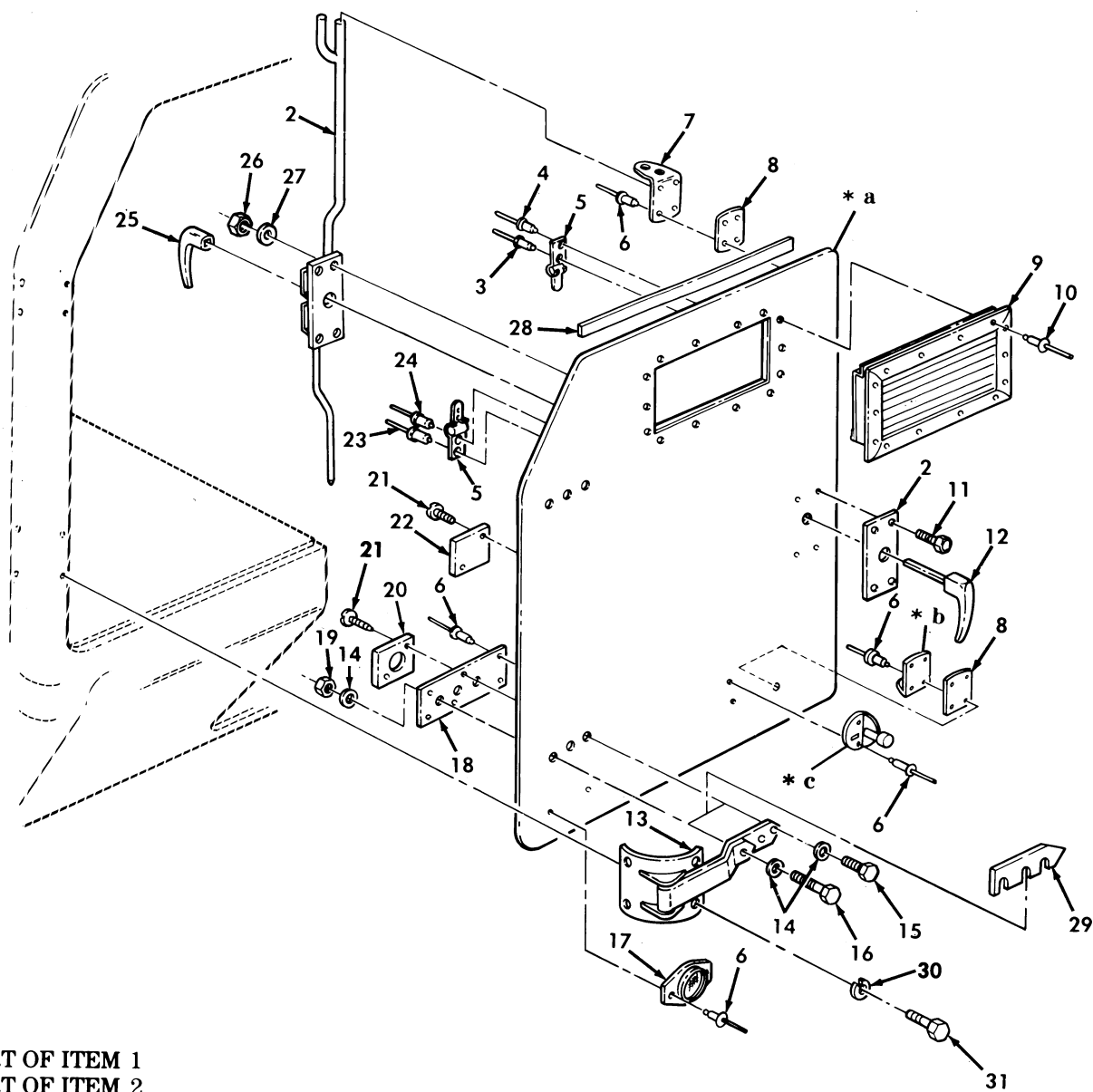
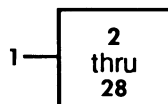

Figure 210. Interior Net Assemblies, Cargo Bulkhead, and Related Items.



SECTION II			TM9-2320-280-24P			
(1)	(2)	(3)	(4)	(5)	(6)	(7)
ITEM NO	SMR CODE	NSN	CAGEC	PART NUMBER	DESCRIPTION AND USABLE ON CODES(UCO)	QTY
					GROUP 1801 BODY,CAB,HOOD,AND HULL ASSEMBLY	
					FIG. 210 INTERIOR NET ASSEMBLIES, CARGO BULKHEAD,AND RELATED ITEMS	
1	PAOZZ	5340014299352	19207	12446813	BRACKET,MOUNTING.....	1
					UOC:B25,C17	
2	PAOZZ	5340014158672	19207	12446812	STRAP,WEBBING.....	1
					UOC:B25,C17	
3	PAOZZ	5305000687837	80204	B1821BH025C063N	SCREW,CAP,HEXAGON H 1/4-20 X 7/16..	4
					UOC:B25,C17	
4	PAOZZ	5310000614650	96906	MS51943-31	NUT,SELF-LOCKING,HE 1/4-20.....	4
					UOC:B25,C17	
5	PAOZZ	5340014086462	19207	12446899	CLAMP,LOOP L.H.....	4
					UOC:B25,C17	
6	PAOZZ	5340014086458	19207	12446900	BRACKET,MOUNTING R.H.....	1
					UOC:B25,C17	
7	PAOZZ	3990014116575	19207	12446811	TIE DOWN,CARGO,VEHI.....	1
					UOC:B25,C17	
8	PAOZZ	2510014114175	34623	12446814	FRAME,STRUCTURAL,VE.....	1
					UOC:B25,C17	
9	PAOZZ	2590014113958	34623	12446773	BRACKET,VEHICULAR C R.H.....	1
					UOC:B25,C17	
10	PAOZZ	7220014318340	19207	12446914	STRIP,ANTI-SKID.....	8
					UOC:B25,C17	
11	PAOZZ	5305013937801	96906	MS24667-52Z	SCREW,CAP,SOCKET HE 3/8-16 X 1.00..	4
					UOC:B25,C17	
12	PAOZZ	5340014086459	19207	12446774	BRACKET,DOUBLE ANGL L.H.....	1
					UOC:B25,C17	
13	PAOZZ	5325014110066	78276	ALS4-1024-130	INSERT,SCREW THREAD.....	40
					UOC:B25,C17	
14	PAOZZ	5310009359021	96906	MS51943-35	NUT,SELF-LOCKING,HE 3/8-16.....	4
					UOC:B25,C17	
15	PAOZZ	5340013145957	19207	12338839-1	LOOP,STRAP FASTENER.....	20
					UOC:B25,C17	
16	PAOZZ	5305014108386	24617	156966	SCREW,MACHINE.....	40
					UOC:B25,C17	

END OF FIGURE



- \* a PART OF ITEM 1
- \* b PART OF ITEM 2
- \* c PART OF ITEM 16 SEE FIGURE 296

Figure 211. Rear Doors, M996 and M996A1 Ambulance.

SECTION II			TM9-2320-280-24P			
(1)	(2)	(3)	(4)	(5)	(6)	(7)
ITEM	SMR			PART		
NO	CODE	NSN	CAGEC	NUMBER	DESCRIPTION AND USABLE ON CODES(UOC)	QTY
					GROUP 1801 BODY,CAB,HOOD,AND HULL ASSEMBLY	
					FIG. 211 REAR DOORS,M996 AND M996A1 AMBULANCE	
1	PAOOO	2510012651138	34623	5597579	DOOR,VEHICULAR L.H. REAR.....	1
					UOC:B16,H16	
1	PAOOO	2510012651139	34623	5597580	DOOR,VEHICULAR R.H. REAR.....	1
					UOC:B16,H16	
2	PAOZZ	5342012646532	27182	J105CCLXBZ02	.LATCH ASSEMBLY,DOOR L.H.,REAR.....	1
					UOC:B16,H16	
2	PFOZZ	5342012665689	27182	RD-860066	.LATCH ASSEMBLY REAR R.H.,DOOR.....	1
					UOC:B16,H16	
3	PAOZZ	5320011357319	11815	CR-213-6-3	.RIVET,BLIND 3/16.....	1
					UOC:B16,H16	
4	PAOZZ	5320000835009	11078	ADS43	.RIVET,BLIND 1/8.....	1
					UOC:B16,H16	
5	PAOZZ	5340012715866	19207	12341798	.CLIP,SPRING TENSION REAR DOOR, L.H.....	2
					UOC:B16,H16	
6	PAOZZ	5320012711834	34623	5575940	.RIVET,SOLID 3/16.....	30
					UOC:B16,H16	
7	PFOZZ		19207	12342296	.GUIDE,LATCHING ROD.....	2
					UOC:B16,H16	
8	PFOZZ	5365012698671	19207	12341407	.SHIM.....	2
					UOC:B16,H16	
9	PFOZZ	2510012758026	34623	5597870	.FRAME SECTION,STRUC REAR DOOR,L.H.	1
					UOC:B16,H16	
10	PAOZZ	5320012716357	9K475	MGLP-B6-4	.RIVET,BLIND 3/16.....	14
					UOC:B16,H16	
11	PAOZZ	5305000712510	80204	B1821BH025C175N	.SCREW,CAP,HEXAGON H 1/4-20 X 1.75.	4
					UOC:B16,H16	
12	PFOZZ	5340012766673	27182	J50062XXBZ01	.HANDLE,DOOR.....	1
					UOC:B16,H16	
13	PFOZZ	2510012646546	71843	R-2423-A	.HINGE,DOOR VEHICULA.....	2
					UOC:B16,H16	
14	PAOZZ	5310000814219	96906	MS27183-12	.WASHER,FLAT 5/16.....	12
					UOC:B16,H16	
15	PAOZZ	5306002264833	80204	B1821BH031C200N	.BOLT,MACHINE 5/16-18 X 2.00.....	4
					UOC:B16,H16	
16	PAOZZ	5306002264834	96906	MS35291-41	.BOLT,MACHINE 5/16-18 X 2.25.....	2
					UOC:B16,H16	
17	PAOZZ	9905002052795	16004	24338	.REFLECTOR,INDICATIN.....	1
					UOC:B16,H16	
18	PFOZZ	5340012708370	19207	12340968	.PLATE,MENDING.....	2
					UOC:B16,H16	
19	PAOZZ	5310008140673	96906	MS51943-33	.NUT,SELF-LOCKING,HE 5/16-18.....	6
					UOC:B16,H16	
20	PAOZZ	5340012708433	19207	12341500-2	.BUMPER,PLASTIC.....	1
					UOC:B16,H16	
21	PAOZZ	5305012705418	3M915	5593430	.SCREW,TAPPING,THREA #10-16 X 1.50.	4
					UOC:B16,H16	

SECTION II			TM9-2320-280-24P			
(1)	(2)	(3)	(4)	(5)	(6)	(7)
ITEM	SMR			PART		
NO	CODE	NSN	CAGEC	NUMBER	DESCRIPTION AND USABLE ON CODES(UOC)	QTY
22	PAOZZ	5340012711846	34623	SF5934196	.BUMPER, PLASTIC.....	1
					UOC: H16	
23	PAOZZ	5320010851755	11815	CR3213-6-1	.RIVET, BLIND 3/16.....	1
					UOC: B16, H16	
24	PAOZZ	5320010849234	11815	CR-3213-6-6	.RIVET, BLIND 3/16.....	1
					UOC: B16, H16	
25	PFOZZ	5340012658911	27182	J500IHXXBZ01	.HANDLE, DOOR.....	1
					UOC: B16, H16	
26	PAOZZ	5310000614650	96906	MS51943-31	.NUT, SELF-LOCKING, HE 1/4-20.....	4
					UOC: B16, H16	
27	PAOZZ	5310008094058	96906	MS27183-10	.WASHER, FLAT 1/4.....	4
					UOC: B16, H16	
28	PAOZZ	5330012984713	19207	12338807-6	.SEAL, PLAIN.....	2
					UOC: B16, H16	
29	PFOZZ	5365012698672	19207	12340984	SHIM.....	V
					UOC: B16, H16	
30	PAOZZ	5310004079566	96906	MS35338-45	WASHER, LOCK 5/16.....	16
					UOC: B16, H16	
31	PAOZZ	5306002264829	80204	B1821BH031C125N	BOLT, MACHINE 5/16-18 X 1.25.....	16
					UOC: B16, H16	

END OF FIGURE

1  
2  
thru  
28

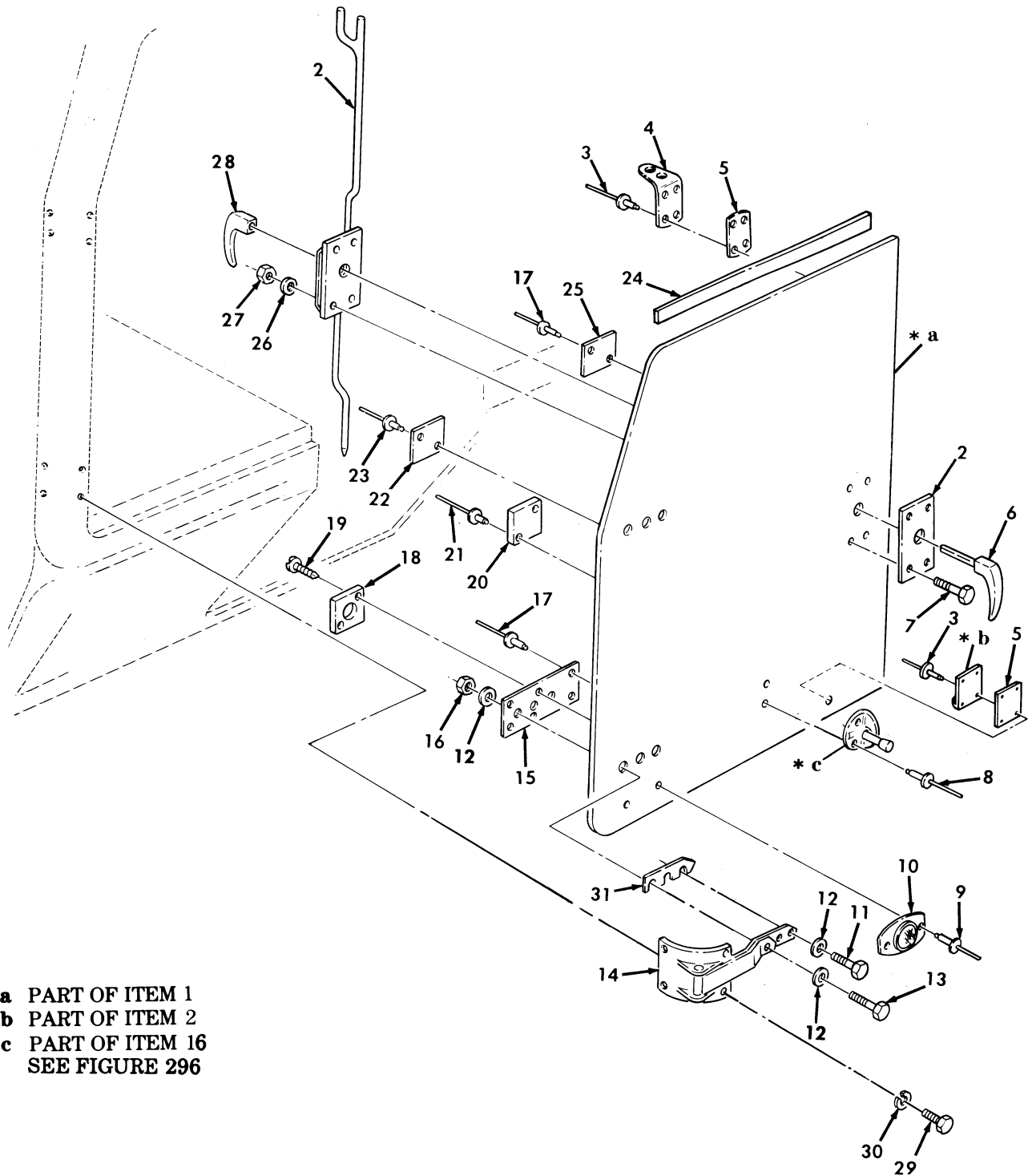

Figure 212. Rear Doors, M997, M997A1, and M997A2 Ambulance.

SECTION II			TM9-2320-280-24P			
(1)	(2)	(3)	(4)	(5)	(6)	(7)
ITEM	SMR			PART		
NO	CODE	NSN	CAGEC	NUMBER	DESCRIPTION AND USABLE ON CODES(UOC)	QTY
					GROUP 1801 BODY,CAB,HOOD,AND HULL ASSEMBLY	
					FIG. 212 REAR DOORS,M997,M997A1,AND M997A2 AMBULANCE	
1	PAOOO	2510012651140	19207	12341782-1	DOOR,VEHICULAR REAR,L.H.....	1
					UOC:A15,B15,H15	
1	PAOOO	2510012651141	19207	12341782-2	DOOR,VEHICULAR REAR,R.H.....	1
					UOC:A15,B15,H15	
2	PAOZZ	5342012653672	19207	12341711-2	.LATCH ASSEMBLY,DOOR REAR DOOR, L.H.....	1
					UOC:A15,B15,H15	
2	PFOZZ	5342012646533	19207	12341711-1	.LATCH ASSEMBLY,DOOR REAR DOOR, R.H.....	1
					UOC:A15,B15,H15	
3	PAOZZ	5320012711834	34623	5575940	.RIVET,SOLID 3/16.....	8
					UOC:A15,B15,H15	
4	PFOZZ		19207	12342296	.GUIDE,LATCHING ROD.....	1
					UOC:A15,B15,H15	
5	PFOZZ	5365012698671	19207	12341407	.SHIM.....	V
					UOC:A15,B15,H15	
6	PFOZZ	5340012766673	27182	J50062XXBZ01	.HANDLE,DOOR.....	1
					UOC:A15,B15,H15	
7	PAOZZ	5305000712510	80204	B1821BH025C175N	.SCREW,CAP,HEXAGON H 1/4-20 X 1.75.	4
					UOC:A15,B15,H15	
8	PAOZZ	5320010849235	11815	CR-3213-6-5	.RIVET,BLIND 3/16.....	2
					UOC:A15,B15,H15	
9	PAOZZ	5320011361782	11815	CR3213-6-4	.RIVET,BLIND 3/16.....	2
					UOC:A15,B15,H15	
10	PAOZZ	9905002052795	96906	MS35387-1	.REFLECTOR,INDICATIN.....	1
					UOC:A15,B15,H15	
11	PAOZZ	5306002264833	80204	B1821BH031C200N	.BOLT,MACHINE 5/16-18 X 2.00.....	4
					UOC:A15,B15,H15	
12	PAOZZ	5310000814219	96906	MS27183-12	.WASHER,FLAT 5/16.....	12
					UOC:A15,B15,H15	
13	PAOZZ	5306002264834	96906	MS35291-41	.BOLT,MACHINE 5/16-18 X 2.25.....	2
					UOC:A15,B15,H15	
14	PFOZZ	2510012646546	71843	R-2423-A	.HINGE,DOOR VEHICULA.....	2
					UOC:A15,B15,H15	
15	PFOZZ	5340012708370	19207	12340968	.PLATE,MENDING.....	2
					UOC:A15,B15,H15	
16	PAOZZ	5310008140673	96906	MS51943-33	.NUT,SELF-LOCKING,HE 5/16-18.....	6
					UOC:A15,B15,H15	
17	PAOZZ	5320007219062	80205	MS20470AD6-10	.RIVET,SOLID 3/16.....	12
					UOC:A15,B15,H15	
18	PAOZZ	5340012708433	19207	12341500-2	.BUMPER,PLASTIC.....	1
					UOC:A15,B15,H15	
19	PAOZZ	5305012705418	3M915	5593430	.SCREW,TAPPING,THREA #10-16 X 1.50.	2
					UOC:A15,B15,H15	
20	PAOZZ	5340012711846	34623	SF5934196	.BUMPER,PLASTIC.....	1
					UOC:A15,B15,H15	
21	PAOZZ	5320012751998	11815	BAPKTR-64	.RIVET,BLIND 3/16.....	2

SECTION II			TM9-2320-280-24P			
(1)	(2)	(3)	(4)	(5)	(6)	(7)
ITEM	SMR			PART		
NO	CODE	NSN	CAGEC	NUMBER	DESCRIPTION AND USABLE ON CODES(UOC)	QTY
22	PAOZZ	5340012708432	19207	12341500-1	UOC:A15,B15,H15 .BUMPER,PLASTIC.....	1
23	PAOZZ	5320010849234	11815	CR3213-6-06	UOC:A15,B15,H15 .RIVET,BLIND 3/16.....	4
24	PAOZZ	5330012984713	19207	12338807-6	UOC:A15,B15,H15 .SEAL,PLAIN.....	2
25	PAOZZ	5340012708431	19207	12341500-3	UOC:A15,B15,H15 .BUMPER,PLASTIC.....	1
26	PAOZZ	5310008094058	96906	MS27183-10	UOC:A15,B15,H15 .WASHER,FLAT 1/4.....	1
27	PAOZZ	5310000614650	96906	MS51943-31	UOC:A15,B15,H15 .NUT,SELF-LOCKING,HE 1/4-20.....	1
28	PFOZZ	5340012658911	27182	J500IHXXBZ01	UOC:A15,B15,H15 .HANDLE,DOOR.....	1
29	PAOZZ	5306002264829	80204	B1821BH031C125N	UOC:A15,B15,H15 BOLT,MACHINE 5/16-18 X 1.25.....	16
30	PAOZZ	5310004079566	96906	MS35338-45	UOC:A15,B15,H15 WASHER,LOCK 5/16.....	16
31	PFOZZ	5365012698672	19207	12340984	UOC:A15,B15,H15 SHIM.....	V

END OF FIGURE

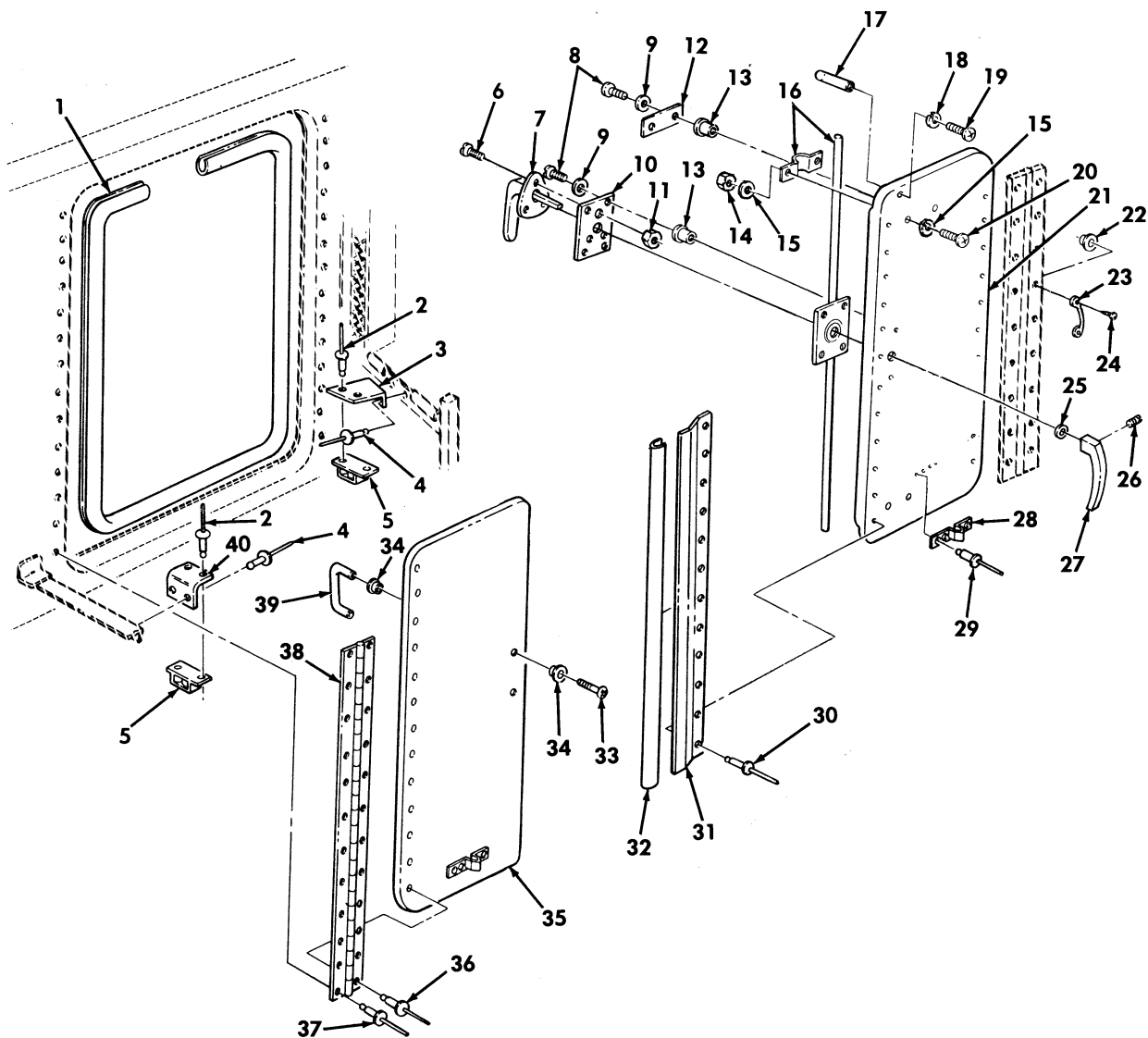

Figure 213. Bulkhead Doors and Related Parts, M996 and M996A1 Ambulance.



SECTION II			TM9-2320-280-24P			
(1)	(2)	(3)	(4)	(5)	(6)	(7)
ITEM	SMR			PART		
NO	CODE	NSN	CAGEC	NUMBER	DESCRIPTION AND USABLE ON CODES(UC)	QTY
					GROUP 1801 BODY,CAB,HOOD,AND HULL ASSEMBLY	
					FIG. 213 BULKHEAD DOORS AND RELATED PARTS,M996 AND M996A1 AMBULANCE	
1	PAOZZ	5330012658948	19207	12341625-2	SEAL, NONMETALLIC SP.....	1
					UOC: B16, H16	
2	PAOZZ	5320012716357	9K475	MGLP-B6-4	RIVET, BLIND 3/16.....	4
					UOC: B16, H16	
3	PAOZZ	5340012723353	19207	12341485	BRACKET, ANGLE.....	1
					UOC: B16, H16	
4	PAOZZ	5320001177291	96906	MS20426AD6-12	RIVET, SOLID 3/16.....	4
					UOC: B16, H16	
5	PAOZZ	2540012702250	19220	7-1910	LATCH, DOOR, VEHICULA.....	2
					UOC: B16, H16	
6	PAOZZ	5305009881725	96906	MS35206-281	SCREW, MACHINE 1/4-20 X 3/4.....	3
					UOC: B16, H16	
7	PAOZZ	5340012767415	34623	12341746	HANDLE, DOOR.....	1
					UOC: B16, H16	
8	PAOZZ	5305009881727	96906	MS35206-283	SCREW, MACHINE 1/4-20 X 1.00.....	8
					UOC: B16, H16	
9	PAOZZ	5306002258498	96906	MS90725-33	BOLT, MACHINE 1/4.....	8
					UOC: B16, H16	
10	PAOZZ	5340012732342	34623	5597096	COVER, ACCESS.....	1
					UOC: B16, H16	
11	PAOZZ	5310009050762	96906	MS51967-3	NUT, PLAIN, HEXAGON 1/4-20.....	3
					UOC: B16, H16	
12	PAOZZ	5340012708483	34623	5597090	COVER, ACCESS.....	2
					UOC: B16, H16	
13	PAOZZ	4931012028692	19207	12339998-13	PLUSNUT.....	4
					UOC: B16, H16	
14	PAOZZ	5310009349758	96906	MS35649-202	NUT, PLAIN, HEXAGON #10-24.....	4
					UOC: B16, H16	
15	PAOZZ	5310000145850	96906	MS27183-42	WASHER, FLAT.....	8
					UOC: B16, H16	
16	PAOZZ	5340013101189	27182	J95CCXXXBZ02	BOLT, EXIT.....	1
					UOC: B16, H16	
17	PAOZZ	5315012698504	19207	12341388	PIN, STRAIGHT, HEADLE.....	1
					UOC: B16, H16	
18	PAOZZ	5310000454007	96906	MS35338-41	WASHER, LOCK #6.....	1
					UOC: B16, H16	
19	PAOZZ	5305009844988	96906	MS35206-228	SCREW, MACHINE #6-32 X 3/8.....	1
					UOC: B16, H16	
20	PAOZZ	5305009846210	96906	MS35206-263	SCREW, MACHINE.....	4
					UOC: B16, H16	
21	PFOZZ	2510012651126	19207	12341778	DOOR, BULKHEAD ASSEM.....	1
					UOC: B16, H16	
22	PAOZZ	5310013953549	96906	MS27130-A28	NUT, PLAIN, BLIND RIV #10-32.....	2
					UOC: A15, B15, B16, H15, H16	
23	PAOZZ	5340013145957	19207	12338839-1	LOOP, STRAP FASTENER.....	1
					UOC: H15, H16	
24	PAOZZ	5305011850114	7X677	157166	SCREW #10-32 X 3/4.....	2

SECTION II			TM9-2320-280-24P			
(1)	(2)	(3)	(4)	(5)	(6)	(7)
ITEM	SMR			PART		
NO	CODE	NSN	CAGEC	NUMBER	DESCRIPTION AND USABLE ON CODES(UOC)	QTY
25	PAOZZ	5310012043344	76301	4M116-04004	UOC:H15,H16 WASHER,FLAT.....	1
26	PAOZZ	5305007286274	80205	MS51973-50	UOC:B16,H16 SETSCREW.....	1
27	PAOZZ	5340012658911	27182	J500IHXXBZ01	UOC:B16,H16 HANDLE,DOOR.....	1
28	PAOZZ	5340012708435	19220	7-2414	UOC:B16,H16 STRIKE,CATCH.....	2
29	PAOZZ	5320008990981	54402	AD42BS	UOC:B16,H16 RIVET,BLIND 3/16.....	8
30	PAOZZ	5320005262945	96906	MS20426AD6-4	UOC:B16,H16 RIVET,SOLID 3/16.....	12
31	MOOZZ		34623	12341109-2	UOC:B16,H16 RETAINER,BULKHEAD MAKE FROM SHEET METAL,P/N QQ-A-250/11, 45 INCHES LONG.....	1
32	PAOZZ	5330012658808	34623	SF5934182	UOC:B16,H16 SEAL,PLAIN.....	1
33	PAOZZ	5305009846199	96906	MS35206-251	UOC:B16,H16 SCREW,MACHINE #8-32 X 1.625.....	2
34	PAOZZ	5310012881257	87541	4487(US26D)	UOC:B16,H16 WASHER,RECESSED.....	4
35	PFOZZ	2510012738376	19207	12341418	UOC:B16,H16 DOOR,BULKHEAD ASSEM.....	1
36	PAOZZ	5320011435075	11815	CR-213-6-2	UOC:B16,H16 RIVET,BLIND 3/16.....	24
37	PAOZZ	5320011357319	11815	CR-213-6-3	UOC:B16,H16 RIVET,BLIND 3/16.....	24
38	PAOZZ	5340012725611	34623	5933947	UOC:B16,H16 HINGE,BUTT.....	2
39	PAOZZ	5340012788588	87541	4485(US 27)	UOC:B16,H16 HANDLE,BOW.....	1
40	PAOZZ	5340012778125	19207	12341486	UOC:B16,H16 BRACKET,ANGLE.....	1

END OF FIGURE

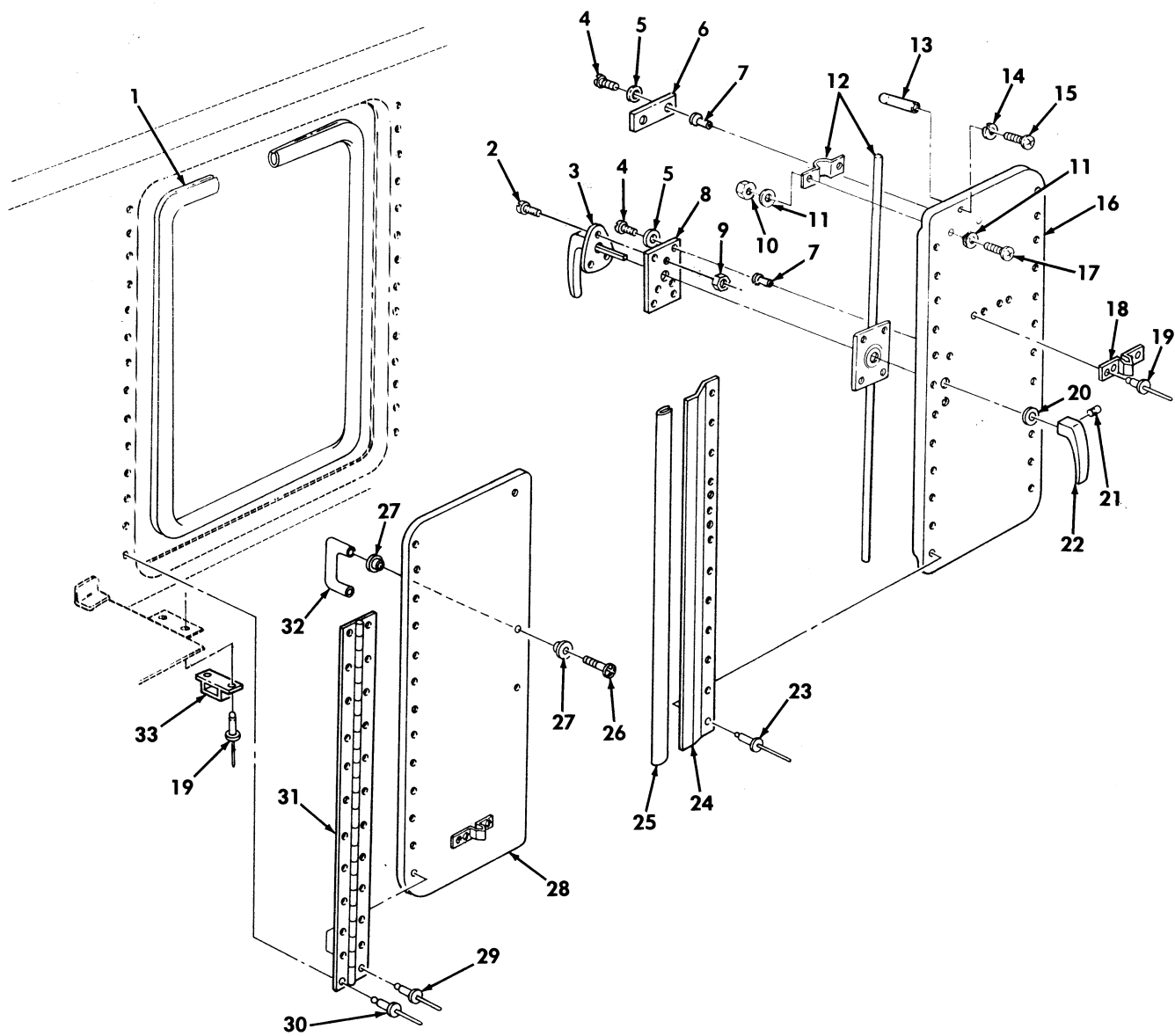

Figure 214. Bulkhead Doors and Related Parts, M997, M997A1, and M997A2 Ambulance.

SECTION II			TM9-2320-280-24P			
(1)	(2)	(3)	(4)	(5)	(6)	(7)
ITEM	SMR			PART		
NO	CODE	NSN	CAGEC	NUMBER	DESCRIPTION AND USABLE ON CODES(UOC)	QTY
					GROUP 1801 BODY,CAB,HOOD,AND HULL ASSEMBLY	
					FIG. 214 BULKHEAD DOORS AND RELATED PARTS,M997,M997A1,AND M997A2 AMBULANCE	
1	PAOZZ	5330012658804	34623	5934185	SEAL,PLAIN.....	1
					UOC:A15,B15,H15	
2	PAOZZ	5305009881725	96906	MS35206-281	SCREW,MACHINE 1/4-20 X 3/4.....	3
					UOC:A15,B15,H15	
3	PAOZZ	5340012767415	27182	J50062XXBZ02	HANDLE,DOOR.....	1
					UOC:A15,B15,H15	
4	PAOZZ	5305000711318	96906	MS51957-83	SCREW,MACHINE 1/4-20 X 1.00.....	8
					UOC:A15,B15,H15	
5	PAOZZ	5310008094058	96906	MS27183-10	WASHER,FLAT 1/4.....	8
					UOC:A15,B15,H15	
6	PAOZZ	5340012708483	19207	12340940	COVER,ACCESS.....	2
					UOC:A15,B15,H15	
7	PAOZZ	4931012028692	19207	12339998-13	PLUSNUT 1/4-20.....	8
					UOC:A15,B15,H15	
8	PAOZZ	5340012732342	19207	12341316	COVER,ACCESS.....	1
					UOC:A15,B15,H15	
9	PAOZZ	5310012538380	34623	5592818	NUT 1/4-20.....	3
					UOC:A15,B15,H15	
10	PAOZZ	5310009349758	96906	MS35649-202	NUT,PLAIN,HEXAGON.....	4
					UOC:A15,B15,H15	
11	PAOZZ	5310000145850	96906	MS27183-42	WASHER,FLAT.....	8
					UOC:A15,B15,H15	
12	PAOZZ	5340013101658	27182	J95CCXRXBZ01	BOLT,EXIT.....	1
					UOC:A15,B15,H15	
13	PAOZZ	5315012698504	19207	12341388	PIN,STRAIGHT,HEADLE.....	1
					UOC:A15,B15,H15	
14	PAOZZ	5310000454007	96906	MS35338-41	WASHER,LOCK #6.....	1
					UOC:A15,B15,H15	
15	PAOZZ	5305000546652	96906	MS51957-28	SCREW,MACHINE #6-32 X 3/8.....	1
					UOC:A15,B15,H15	
16	PAOZZ	2510012656953	19207	12341403	DOOR,VEHICULAR.....	1
					UOC:A15,B15,H15	
17	PAOZZ	5305009846210	96906	MS35206-263	SCREW,MACHINE.....	4
					UOC:A15,B15,H15	
18	PAOZZ	5340012708435	19220	7-2414	STRIKE,CATCH.....	2
					UOC:A15,B15,H15	
19	PAOZZ	5320008990981	54402	AD42BS	RIVET,BLIND 3/16.....	12
					UOC:A15,B15,H15	
20	PAOZZ	5310012043344	76301	4M116-04004	WASHER,FLAT.....	1
					UOC:A15,B15,H15	
21	PAOZZ	5305007286274	96906	MS51973-50	SETSCREW 1/4-20.....	1
					UOC:A15,B15,H15	
22	PAOZZ	5340012658911	27182	J500IHXXBZ01	HANDLE,DOOR.....	1
					UOC:A15,B15,H15	
23	PFOZZ	5320012716357	9K475	MGLP-B6-4	RIVET,BLIND 3/16.....	12
					UOC:A15,B15,H15	

SECTION II			TM9-2320-280-24P			
(1)	(2)	(3)	(4)	(5)	(6)	(7)
ITEM	SMR			PART		
NO	CODE	NSN	CAGEC	NUMBER	DESCRIPTION AND USABLE ON CODES(UOC)	QTY
24	MOOZZ		19207	12341109	BRACKET,DOUBLE ANGL MAKE FROM SHEET METAL,P/N QQ-A-250/11,60 INCHES LONG UOC:A15,B15,H15	1
25	PAOZZ	5330012658805	34623	5934184	SEAL,PLAIN..... UOC:A15,B15,H15	1
26	PAOZZ	5305009846199	96906	MS35206-251	SCREW,MACHINE #8-32 X 1-1/2..... UOC:A15,B15,H15	2
27	PAOZZ	5310012881257	87541	4487(US26D)	WASHER,RECESSED..... UOC:A15,B15,H15	4
28	PFOZZ	2510012651130	19207	12341779	DOOR,VEHICULAR..... UOC:A15,B15,H15	1
29	PAOZZ	5320011435075	11815	CR-213-6-2	RIVET,BLIND 3/16..... UOC:A15,B15,H15	24
30	PAOZZ	5320011357319	11815	CR-213-6-3	RIVET,BLIND 3/16..... UOC:A15,B15,H15	24
31	PAOZZ	5340012728410	34623	5589961	HINGE,BUTT..... UOC:A15,B15,H15	2
32	PAOZZ	5340012788588	87541	4485(US 27)	HANDLE,BOW..... UOC:A15,B15,H15	1
33	PAOZZ	2540012702250	19220	7-1910	LATCH,DOOR,VEHICULA..... UOC:A15,B15,H15	2

END OF FIGURE

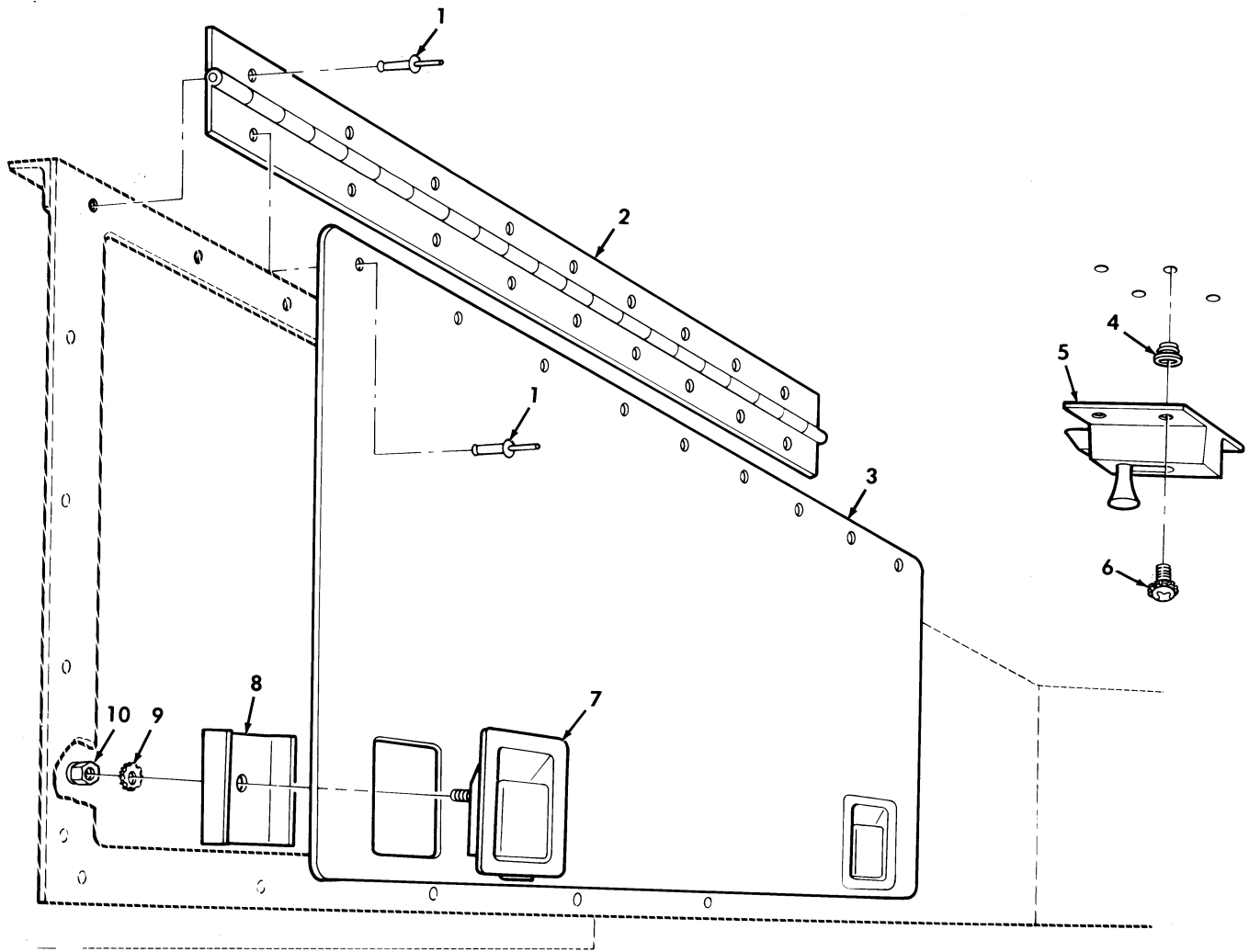

Figure 215. NBC Panel Door and Related Hardware, M997, M997A1, and M997A2 Ambulance.

SECTION II			TM9-2320-280-24P			
(1)	(2)	(3)	(4)	(5)	(6)	(7)
ITEM	SMR			PART		
NO	CODE	NSN	CAGEC	NUMBER	DESCRIPTION AND USABLE ON CODES(UCO)	QTY
					GROUP 1801 BODY,CAB,HOOD,AND HULL ASSEMBLY	
					FIG. 215 NBC PANEL DOOR AND RELATED HARDWARE,M997,M997A1,AND M997A2 AMBULANCE	
1	PAOZZ	5320012716357	9K475	MGLP-B6-4	RIVET,BLIND 3/16.....	18
					UCO:A15,B15,H15	
2	PAOZZ	5340012728409	19207	12341413	HINGE,BUTT.....	1
					UCO:A15,B15,H15	
3	PAOZZ	2510012664003	19207	12341217	PANEL,BODY,VEHICULA.....	1
					UCO:A15,B15,H15	
4	PAOZZ	5310009647092	03481	A10-116	NUT,PLAIN,BLIND RIV #10-32.....	4
					UCO:A15,B15,H15	
5	PAOZZ	5340012716361	27182	90-SN	BOLT,BARREL.....	1
					UCO:A15,B15,H15	
6	PAOZZ	5305012560406	34623	5593006	SCREW,ASSEMBLED WAS #10-32 X .75...	4
					UCO:A15,B15,H15	
7	PAOZZ	5340012774613	94222	64-10-201-90	LATCH SET,RIM.....	2
					UCO:A15,B15,H15	
8	PAOZZ	5340012732381	19207	12341491	STRAP,RETAINING.....	2
					UCO:A15,B15,H15	
9	PAOZZ	5310000809786	96906	MS45904-60	WASHER,LOCK #10.....	2
					UCO:A15,B15,H15	
10	PAOZZ	5310000131482	12204	131482	NUT,PLAIN,CAP #10-32.....	2
					UCO:A15,B15,H15	

END OF FIGURE

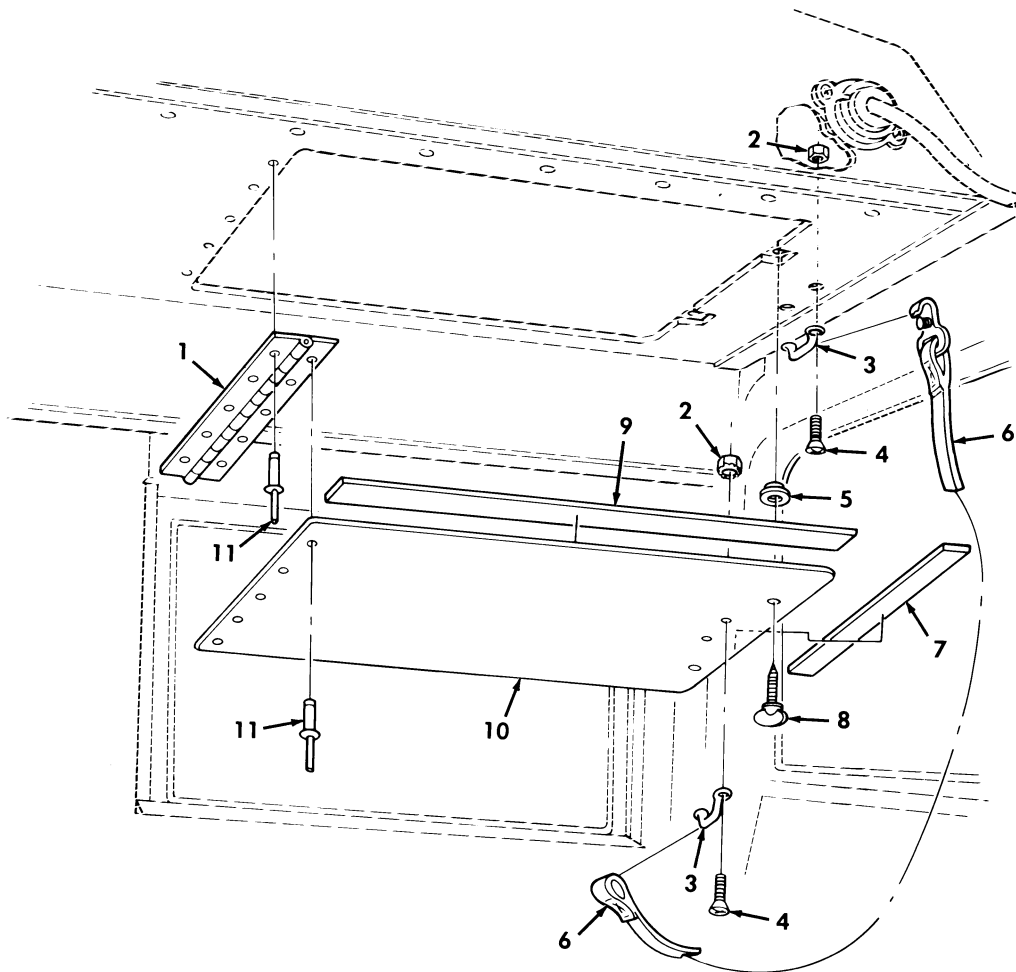
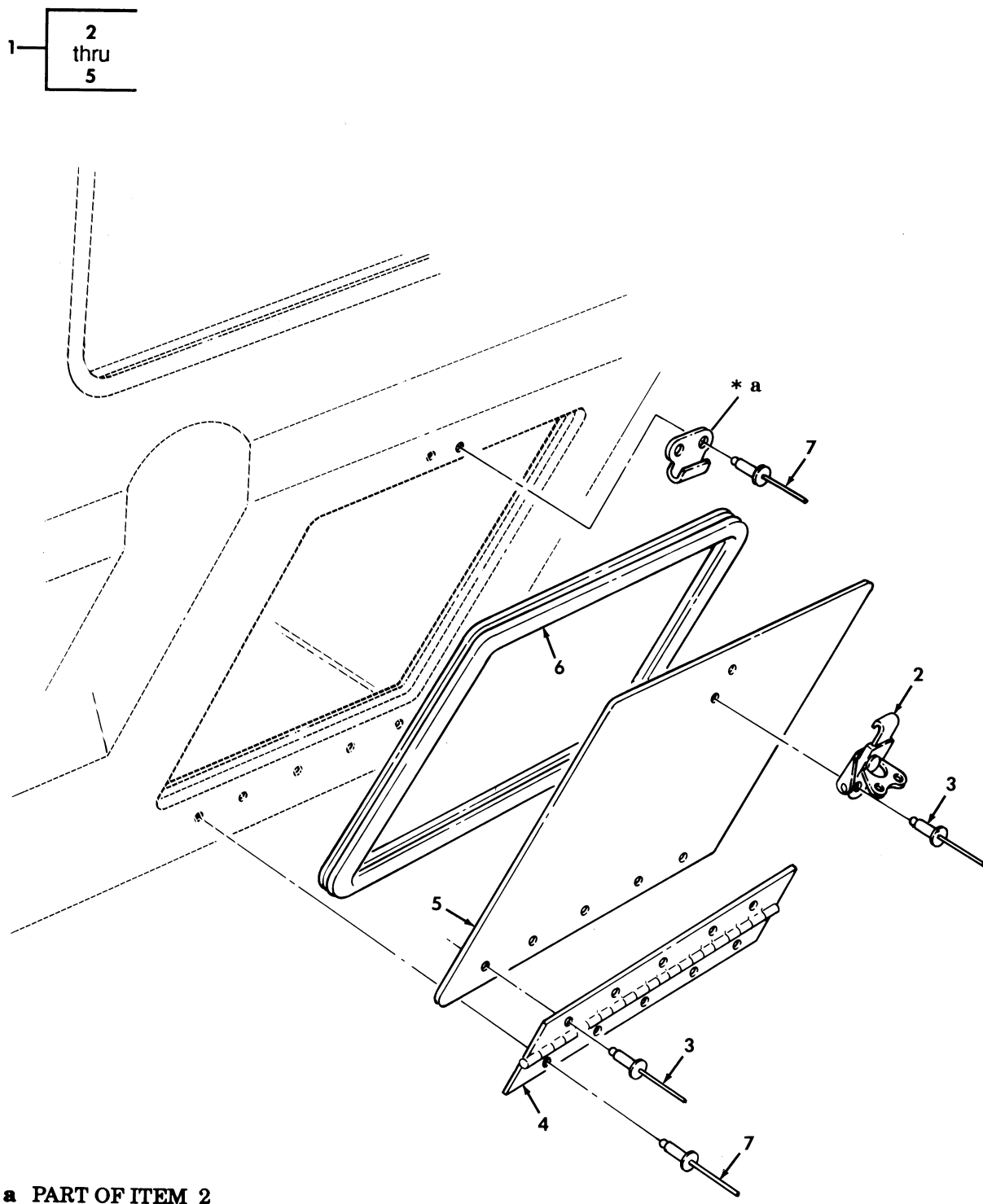

Figure 216. NBC Access Door and Related Hardware, M996 and M996A1 Ambulance.



SECTION II			TM9-2320-280-24P			
(1)	(2)	(3)	(4)	(5)	(6)	(7)
ITEM	SMR			PART		
NO	CODE	NSN	CAGEC	NUMBER	DESCRIPTION AND USABLE ON CODES(UOC)	QTY
					GROUP 1801 BODY,CAB,HOOD,AND HULL ASSEMBLY	
					FIG. 216 NBC ACCESS DOOR AND RELATED HARDWARE,M996 AND M996A1 AMBULANCE	
1	PAOZZ	5340012743498	34623	5597710	HINGE,BUTT.....	1
					UOC:B16,H16	
2	PAOZZ	5310012708189	34623	5593413	NUT #10-32.....	4
					UOC:B16,H16	
3	PAOZZ	5340011978673	34623	5581307	HANDLE,BOW.....	2
					UOC:B16,H16	
4	PAOZZ	5305005829501	82386	410-63	SCREW,CAP,HEXAGON H #10-32 X .50...	4
					UOC:B16,H16	
5	PAOZZ	5310008809344	94222	12-11014-12	WASHER,LOCK.....	2
					UOC:B16,H16	
6	PAOZZ	5340012658924	19207	12341637	STRAP,WEBBING.....	1
					UOC:B16,H16	
7	MOOZZ		34623	SF5597994	SEAL MAKE FROM SEAL, P/N R-495-T, 14.70 INCHES LONG.....	1
					UOC:B16,H16	
8	PAOZZ	5305011852211	94222	12-12-404-11	SCREW,PANEL FASTENE.....	2
					UOC:B16,H16	
9	MOOZZ		34623	SF5597995	SEAL MAKE FROM SEAL, P/N R-495-T, 17 INCHES LONG.....	2
					UOC:B16,H16	
10	PFOZZ	2510012665711	19207	12341536	PANEL,BODY,VEHICULA.....	1
					UOC:B16,H16	
11	PAOZZ	5320012716357	9K475	MGLP-B6-4	RIVET,BLIND 3/16.....	10
					UOC:B16,H16	

END OF FIGURE



**\* a PART OF ITEM 2**

*Figure 217. Litter Tray Stowage Door, M996, M996A1, M997, M997A1, and M997A2 Ambulance.*

SECTION II			TM9-2320-280-24P			
(1)	(2)	(3)	(4)	(5)	(6)	(7)
ITEM	SMR			PART		
NO	CODE	NSN	CAGEC	NUMBER	DESCRIPTION AND USABLE ON CODES(UC)	QTY
					GROUP 1801 BODY,CAB,HOOD,AND HULL ASSEMBLY	
					FIG. 217 LITTER TRAY STOWAGE DOOR, M996,M996A1,M997,M997A1,AND M997A2 AMBULANCE	
1	PFOOO	5342012665691	19207	12341111	DOOR,ACCESS.....	1
					UOC:A15,B15,B16,H15,H16	
2	PAOZZ	5340012609942	1E045	3-10	.CATCH,CLAMPING.....	1
					UOC:A15,B15,B16,H15,H16	
3	PAOZZ	5320012645978	9K475	MGLP-B6-7	.RIVET,BLIND 3/16.....	7
					UOC:A15,B15,B16,H15,H16	
4	PAOZZ	5340012724942	34623	5589357	.HINGE,BUTT.....	1
					UOC:A15,B15,B16,H15,H16	
5	PAOZZ	5342012750532	34623	5589336	.DOOR,ACCESS.....	1
					UOC:A15,B15,B16,H15,H16	
6	MOOZZ		34623	5592085	SEAL,NONMETALLIC SP MAKE FROM SEAL, P/N IC006197,34 INCHES LONG.....	1
					UOC:A15,B15,B16,H15,H16	
7	PAOZZ	5320012716357	9K475	MGLP-B6-4	RIVET,BLIND 3/16.....	7
					UOC:A15,B15,B16,H15,H16	

END OF FIGURE

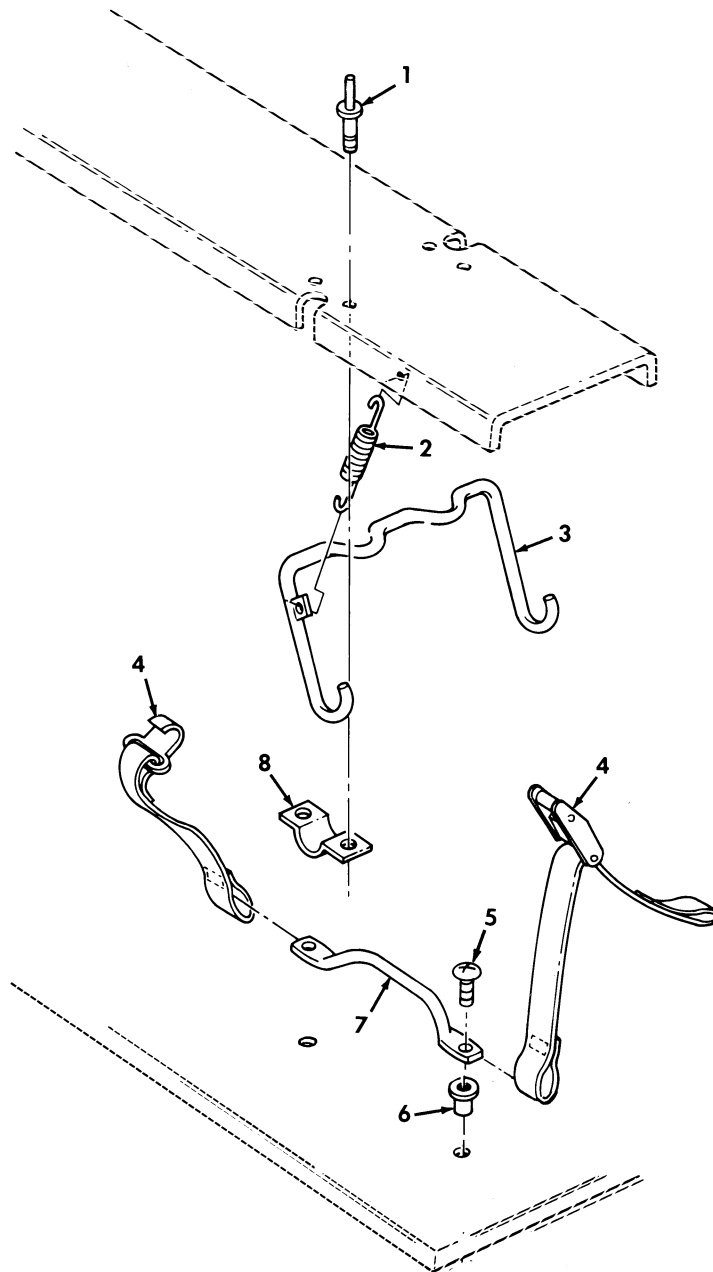

Figure 218. Litter Tray Stowage, M997, M997A1, and M997A2 Ambulance.

SECTION II			TM9-2320-280-24P			
(1)	(2)	(3)	(4)	(5)	(6)	(7)
ITEM	SMR			PART		
NO	CODE	NSN	CAGEC	NUMBER	DESCRIPTION AND USABLE ON CODES(UC)	QTY
					GROUP 1801 BODY,CAB,HOOD,AND HULL ASSEMBLY	
					FIG. 218 LITTER TRAY STOWAGE,M997, M997A1,AND M997A2 AMBULANCE	
1	PAOZZ	5320011357319	11815	CR-213-6-3	RIVET,BLIND 3/16.....	4
					UOC:A15,B15,H15	
2	PAOZZ	5360012753512	34623	5589505	SPRING,HELICAL,EXTE.....	1
					UOC:A15,B15,H15	
3	PAOZZ	2510012665690	19207	12341142	SUPPORT,LITTER STWG.....	1
					UOC:A15,B15,H15	
4	PAOZZ	5340012722801	31272	44647-21	STRAP,WEBBING.....	1
					UOC:A15,B15,H15	
5	PAOZZ	5305000593660	96906	MS51958-64	SCREW,MACHINE #10-32 X .62.....	2
					UOC:A15,B15,H15	
6	PAOZZ	5310004604490	96906	MS27130-S37	NUT,PLAIN,BLIND RIV #10-32.....	2
					UOC:A15,B15,H15	
7	PAOZZ	5340012135735	34623	5591648	LOOP,STRAP FASTENER.....	1
					UOC:A15,B15,H15	
8	PAOZZ	5340012727814	19207	12340935	STRAP,RETAINING.....	2
					UOC:A15,B15,H15	

END OF FIGURE

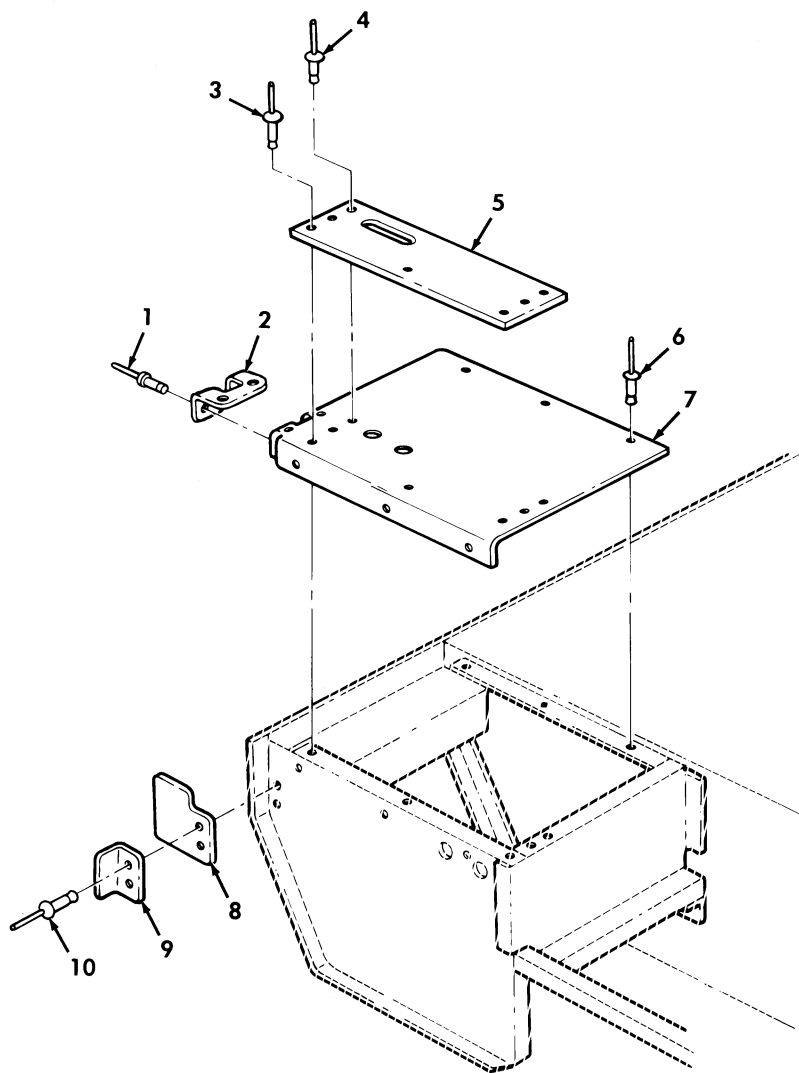

Figure 219. Rear Cover Assembly, Left and Right Hand, M996 and M996A1 Ambulance.

SECTION II			TM9-2320-280-24P			
(1)	(2)	(3)	(4)	(5)	(6)	(7)
ITEM	SMR			PART		
NO	CODE	NSN	CAGEC	NUMBER	DESCRIPTION AND USABLE ON CODES(UC)	QTY
					GROUP 1801 BODY,CAB,HOOD,AND HULL ASSEMBLY	
					FIG. 219 REAR COVER ASSEMBLY,LEFT AND RIGHT HAND,M996 AND M996A1 AMBULANCE	
1	PAOZZ	5320011357319	11815	CR-213-6-3	RIVET,BLIND 3/16.....	8
					UOC:B16,H16	
2	PAOZZ	5340012726578	19207	12340941	BRACKET,ANGLE.....	2
					UOC:B16,H16	
3	PAOZZ	5320010861148	81349	M7885/3-6-06	RIVET,BLIND 3/16.....	8
					UOC:B16,H16	
4	PAOZZ	5320011361785	11815	CR-212-6-4	RIVET,BLIND 3/16.....	4
					UOC:B16,H16	
5	PAOZZ	2540012706459	34623	SF5934158	SKID,COVER REAR.....	2
					UOC:B16,H16	
6	PAOZZ	5320012645978	19207	12339355-2	RIVET,BLIND 3/16.....	12
					UOC:B16,H16	
7	PAOZZ	5340012723361	19207	12341188	COVER,ACCESS L.H.....	1
					UOC:B16,H16	
7	PAOZZ	5340012725517	34623	5597397	COVER,ACCESS R.H.....	1
					UOC:B16,H16	
8	PAOZZ	5330012729995	19207	12341698	GASKET.....	2
					UOC:B16,H16	
9	PAOZZ	5340012774426	34623	5597754	BRACKET,ANGLE.....	2
					UOC:B16,H16	
10	PAOZZ	5320011384239	11815	CR3213-4-3	RIVET,BLIND 1/8.....	4
					UOC:B16,H16	

END OF FIGURE

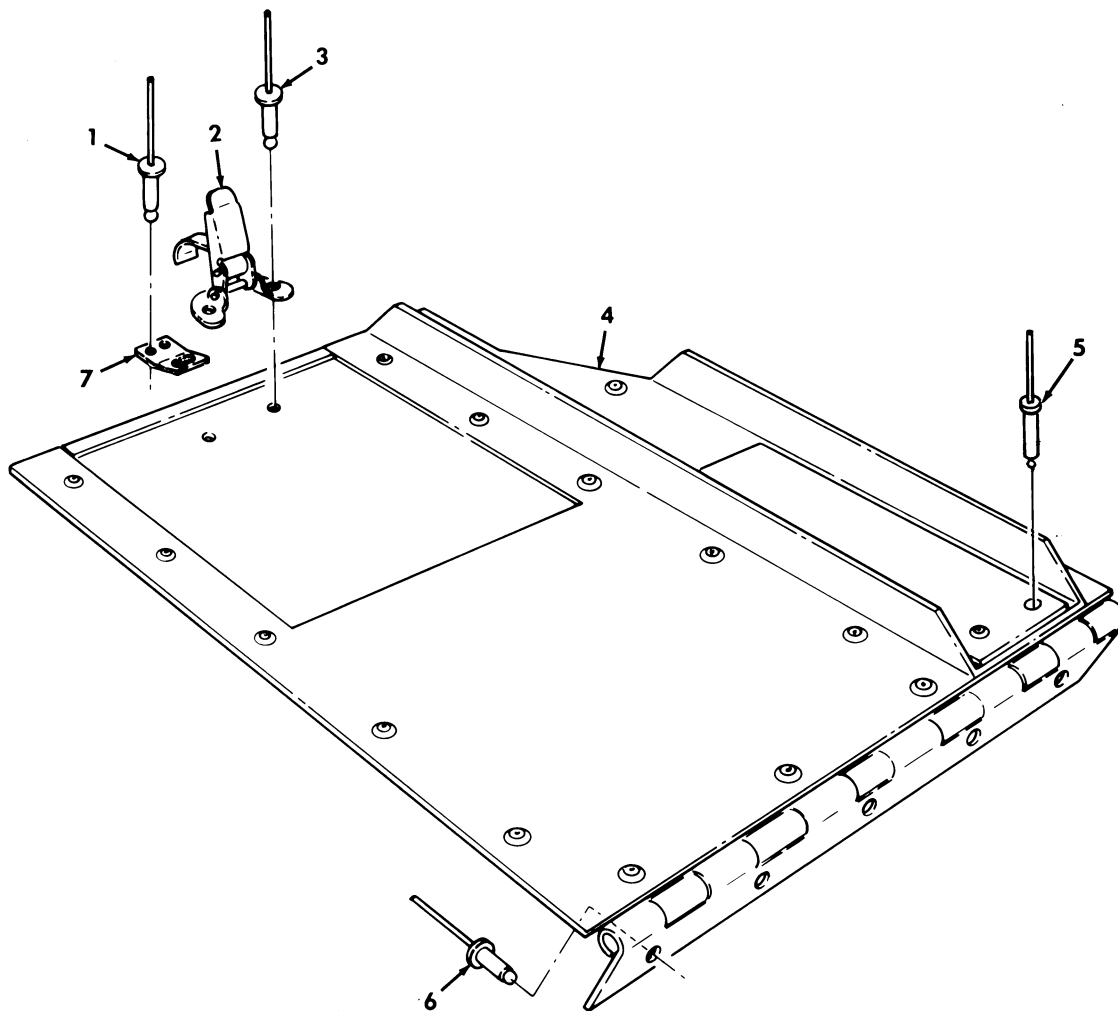

Figure 220. Cover Assembly, Medical Stowage, Left and Right Hand, M996 and M996A1 Ambulance.



SECTION II			TM9-2320-280-24P			
(1)	(2)	(3)	(4)	(5)	(6)	(7)
ITEM	SMR			PART		
NO	CODE	NSN	CAGEC	NUMBER	DESCRIPTION AND USABLE ON CODES(UC)	QTY
					GROUP 1801 BODY,CAB,HOOD,AND HULL ASSEMBLY	
					FIG. 220 COVER ASSEMBLY,MEDICAL STOWAGE,LEFT AND RIGHT HAND,M996 AND M996A1 AMBULANCE	
1	PAOZZ	5320012200596	11815	CR-213-4-4	RIVET,BLIND 1/8.....	8
					UOC:B16,H16	
2	PAOZZ	5340011971294	29372	20L01-1-1AF	CATCH,CLAMPING.....	2
					UOC:B16,H16	
3	PAOZZ	5320012716357	9K475	MGLP-B6-4	RIVET,BLIND 3/16.....	4
					UOC:B16,H16	
4	PAOZZ	5340012719573	34623	5597571	COVER,ACCESS L.H.....	1
					UOC:B16,H16	
4	PAOZZ	5340012719574	34623	5597572	COVER,ACCESS R.H.....	1
					UOC:B16,H16	
5	PAOZZ	5320013542547	80205	NAS9303B-6-03	RIVET,BLIND 3/16.....	2
					UOC:B16,H16	
6	PAOZZ	5320011435075	11815	CR3213-6-2	RIVET,BLIND 3/16.....	8
					UOC:B16,H16	
7	PAOZZ	5340012763615	34623	5993089	STRIKE,CATCH.....	2
					UOC:B16,H16	

END OF FIGURE

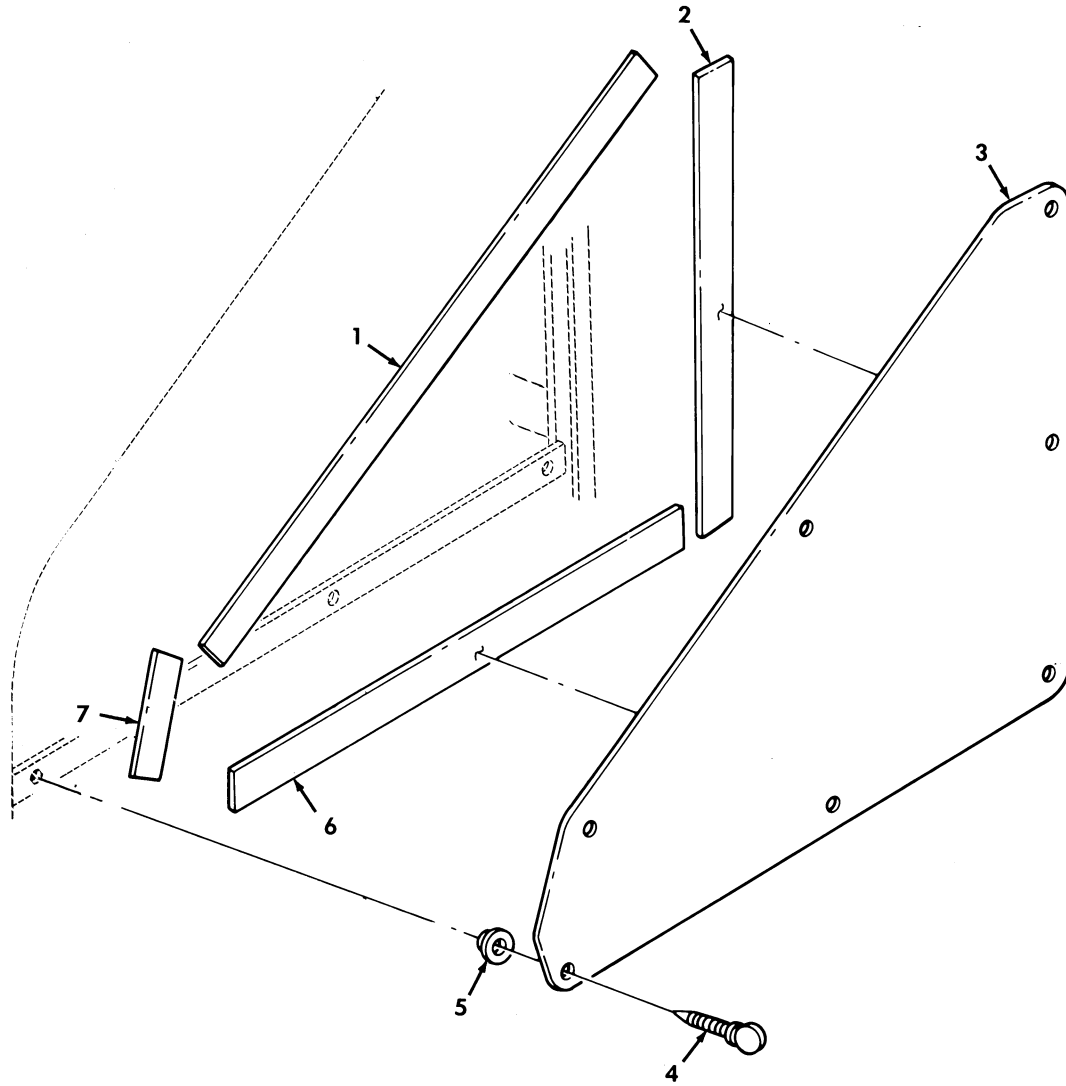

Figure 221. Heater Access Door and Related Hardware, M996 and M996A1 Ambulance.

SECTION II			TM9-2320-280-24P			
(1)	(2)	(3)	(4)	(5)	(6)	(7)
ITEM	SMR			PART		
NO	CODE	NSN	CAGEC	NUMBER	DESCRIPTION AND USABLE ON CODES(UC)	QTY
					GROUP 1801 BODY,CAB,HOOD,AND HULL ASSEMBLY	
					FIG. 221 HEATER ACCESS DOOR AND RELATED HARDWARE,M996 AND M996A1 AMBULANCE	
1	MOOZZ		34623	SF5597999	SEAL MAKE FROM SEAL, P/N R-495-T, 31.28 INCHES LONG.....	1
					UOC:B16,H16	
2	MOOZZ		34623	SF5598000	SEAL MAKE FROM SEAL, P/N R-495-T, 11.56 INCHES LONG.....	1
					UOC:B16,H16	
3	PAOZZ		34623	5935102	PANEL.....	1
					UOC:B16,H16	
4	PAOZZ	5305011852211	94222	12-12-404-11	SCREW,PANEL FASTENE.....	7
					UOC:B16,H16	
5	PAOZZ	5310008809344	94222	12-11014-12	WASHER,LOCK.....	7
					UOC:B16,H16	
6	MOOZZ		34623	SF5597997	SEAL MAKE FROM SEAL, P/N R-495-T, 33.56 INCHES LONG.....	1
					UOC:B16,H16	
7	MOOZZ		34623	SF5597998	SEAL MAKE FROM SEAL, P/N R-495-T, 4.72 INCHES LONG.....	1
					UOC:B16,H16	

END OF FIGURE

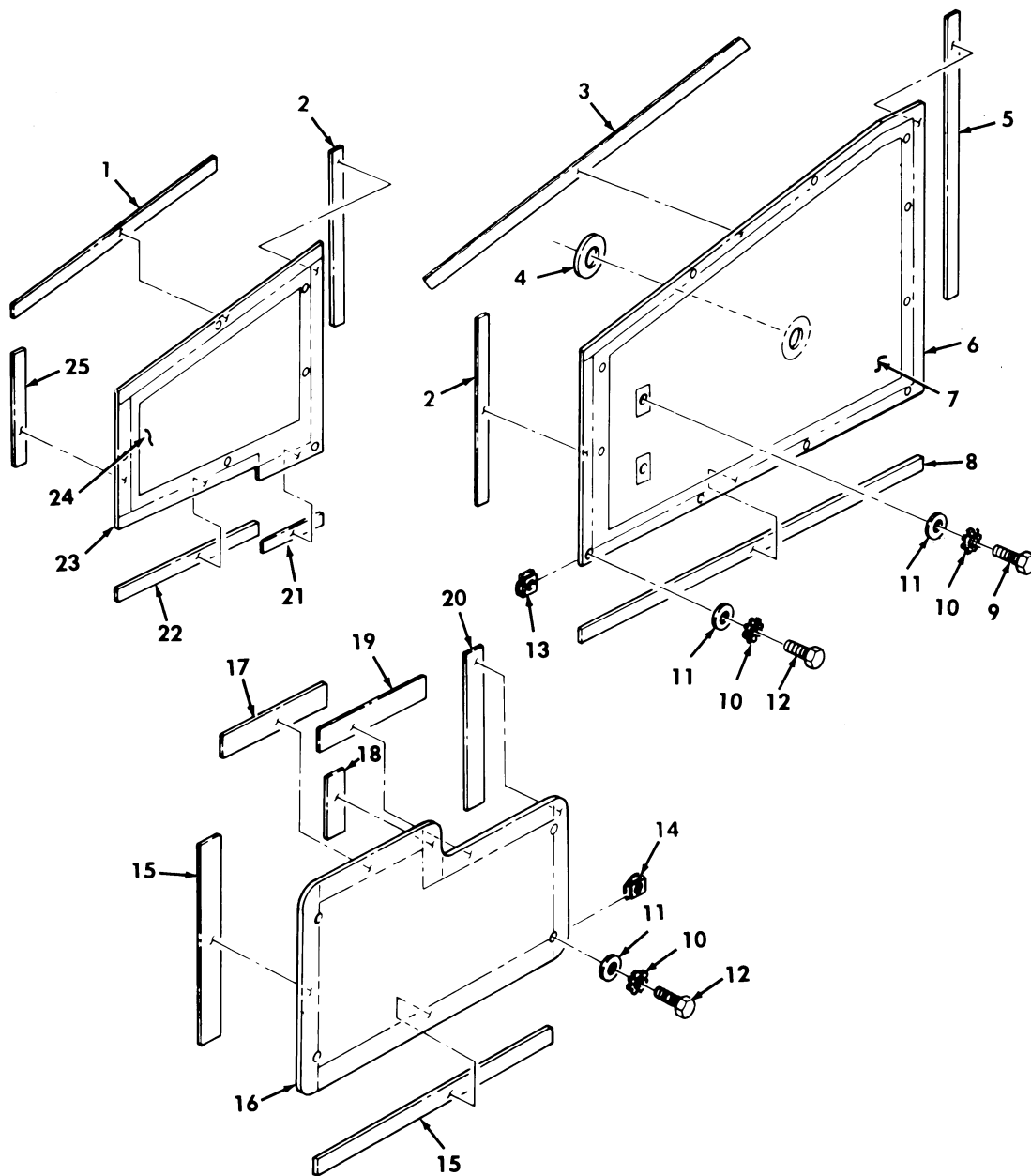

Figure 222. A/C and Heater Compartment Panels and Seals, M997, M997A1, and M997A2 Ambulance.

SECTION II			TM9-2320-280-24P			
(1)	(2)	(3)	(4)	(5)	(6)	(7)
ITEM	SMR			PART		
NO	CODE	NSN	CAGEC	NUMBER	DESCRIPTION AND USABLE ON CODES(UOC)	QTY
					GROUP 1801 BODY,CAB,HOOD,AND HULL ASSEMBLY	
					FIG. 222 A/C AND HEATER COMPARTMENT PANELS AND SEALS,M997,M997A1,AND M997A2 AMBULANCE	
1	MOOZZ		34623	SF5598030	SEAL MAKE FROM SEAL, P/N R-495-T, 18.92 INCHES LONG.....	1
					UOC:A15,B15,H15	
2	MOOZZ		34623	SF5598031	SEAL MAKE FROM SEAL, P/N R-495-T, 16.66 INCHES LONG.....	2
					UOC:A15,B15,H15	
3	MOOZZ		34623	SF5598034	SEAL MAKE FROM SEAL, P/N R-495-T, 29.86 INCHES LONG.....	1
					UOC:A15,B15,H15	
4	PAOZZ	5330012722601	19207	12341617	GASKET.....	1
					UOC:A15,B15,H15	
5	MOOZZ		34623	SF5598036	SEAL MAKE FROM SEAL, P/N R-495-T, 24.50 INCHES LONG.....	1
					UOC:A15,B15,H15	
6	PFOZZ	2510012720537	19207	12341219	PANEL,BODY,VEHICULA.....	1
					UOC:A15,B15,H15	
7	PAOZZ		19207	12341679	INSULATION BLANKET SIDE,R.H.....	1
					UOC:A15,B15,H15	
8	MOOZZ		34623	SF5598035	SEAL MAKE FROM SEAL,P/N R-495-T, 29.42 INCHES LONG.....	1
					UOC:A15,B15,H15	
9	PAOZZ	5305012554606	34623	5592900	SCREW,MACHINE #10-24 X 1/2.....	6
					UOC:A15,B15,H15	
10	PAOZZ	5310000809786	96906	MS45904-60	WASHER,LOCK #10.....	23
					UOC:A15,B15,H15	
11	PAOZZ	5310000145850	96906	MS27183-42	WASHER,FLAT #10.....	23
					UOC:A15,B15,H15	
12	PAOZZ	5305009846213	96906	MS35206-266	SCREW,MACHINE #10-24 X .88.....	17
					UOC:A15,B15,H15	
13	PAOZZ	5310011863483	78553	C46021-1024A-1	NUT,SHEET SPRING #10-24.....	8
					UOC:A15,B15,H15	
14	PAOZZ	5310012751189	78553	C596-1024-24	NUT,SHEET SPRING #10-24.....	4
					UOC:A15,B15,H15	
15	MOOZZ		34623	SF5598062	SEAL MAKE FROM SEAL,P/N R-495-T, 7.56 INCHES LONG.....	2
					UOC:A15,B15,H15	
16	PFOZZ	5340012729145	19207	12341281	COVER,ACCESS.....	1
					UOC:A15,B15,H15	
17	MOOZZ		34623	SF5598065	SEAL MAKE FROM SEAL, P/N R-495-T, 3.72 INCHES LONG.....	1
					UOC:A15,B15,H15	
18	MOOZZ		34623	SF5598064	SEAL MAKE FROM SEAL, P/N R-495-T, 2.50 INCHES LONG.....	1
					UOC:A15,B15,H15	
19	MOOZZ		34623	SF5598063	SEAL MAKE FROM SEAL, P/N R-495-T, 3.28 INCHES LONG.....	1

SECTION II			TM9-2320-280-24P			
(1)	(2)	(3)	(4)	(5)	(6)	(7)
ITEM	SMR			PART		
NO	CODE	NSN	CAGEC	NUMBER	DESCRIPTION AND USABLE ON CODES(UOC)	QTY
20	MOOZZ		34623	5598061	UOC:A15,B15,H15 SEAL MAKE FROM SEAL, P/N R-495-T, 5.56 INCHES LONG.....	1
21	MOOZZ		34623	SF5598033	UOC:A15,B15,H15 SEAL MAKE FROM SEAL, P/N R-495-T, 4.38 INCHES LONG.....	1
22	MOOZZ		34623	5598032	UOC:A15,B15,H15 SEAL MAKE FROM SEAL, P/N R-495-T, 13.76 INCHES LONG.....	1
23	PAOZZ	2510012707922	19207	12341218	UOC:A15,B15,H15 PANEL,BODY,VEHICULA SIDE FRONT.....	1
24	PAOZZ	2510012744901	19207	12341429	UOC:A15,B15,H15 INSULATION BLANKET, SIDE FRONT,R.H.	1
25	MOOZZ		34623	SF5598029	UOC:A15,B15,H15 SEAL MAKE FROM SEAL, P/N R-495-T, 10.62 INCHES LONG..... UOC:A15,B15,H15	1

END OF FIGURE

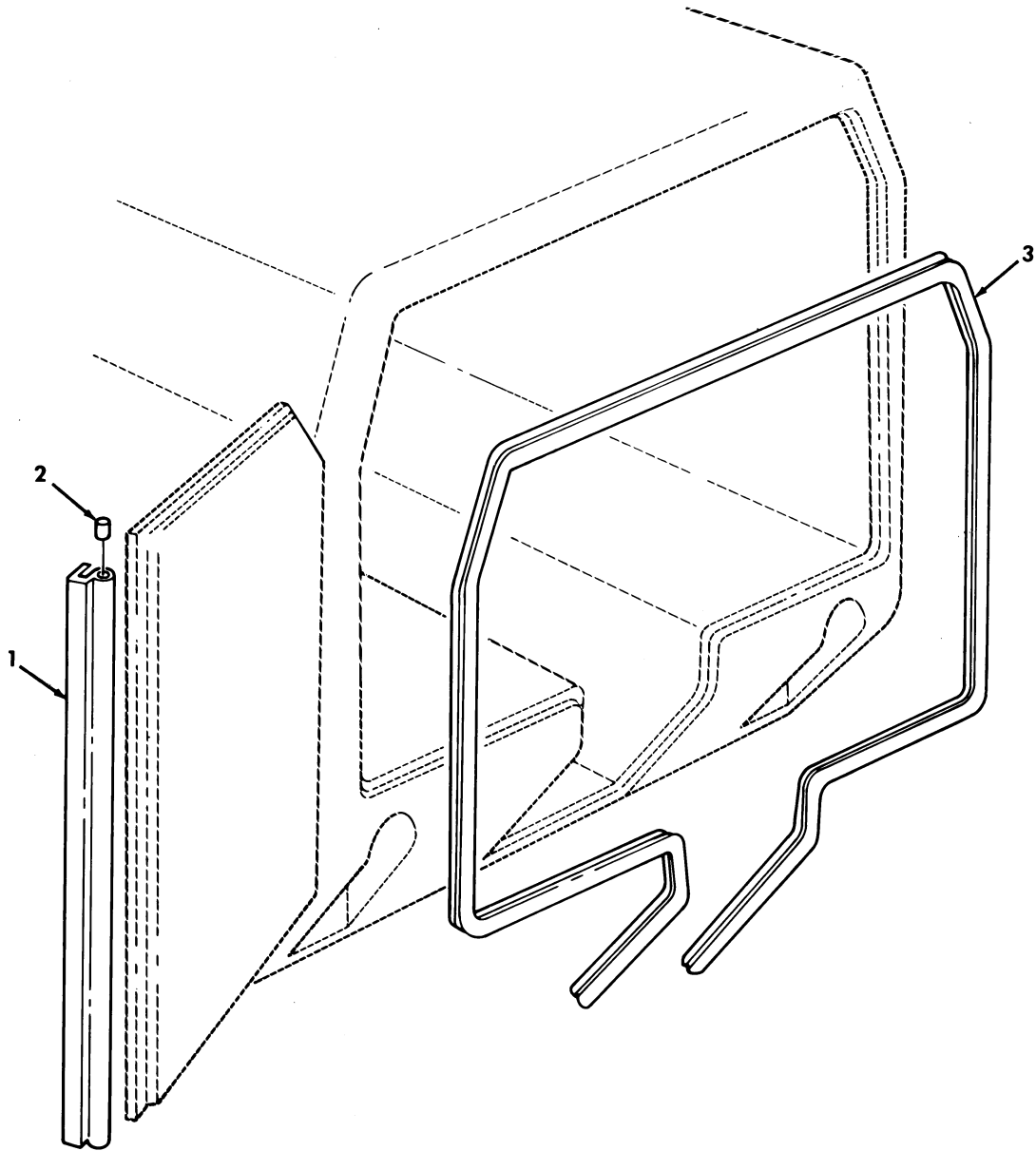

Figure 223. Rear Door Seals, M996, M996A1, M997, M997A1, and M997A2 Ambulance.

SECTION II			TM9-2320-280-24P			
(1)	(2)	(3)	(4)	(5)	(6)	(7)
ITEM	SMR			PART		
NO	CODE	NSN	CAGEC	NUMBER	DESCRIPTION AND USABLE ON CODES(UC)	QTY
					GROUP 1801 BODY,CAB,HOOD,AND HULL ASSEMBLY	
					FIG. 223 REAR DOOR SEALS,M996, M996A1,M997,M997A1,AND M997A2 AMBULANCE	
1	PAOZZ	5330012658947	19207	12341211-8	SEAL,NONMETALLIC SP 47 INCHES LONG.	1
					UC:A15,B15,H15	
1	PAOZZ	5330012658807	19207	12341211-2	SEAL,PLAIN 31.44 INCHES LONG.....	1
					UC:B16,H16	
2	PAOZZ	5330012727727	19207	12341796	RUBBER ROUND SECTIO TOP.....	1
					UC:A15,B15,B16,H15,H16	
3	PAOZZ	5330012658946	19207	12341211-9	SEAL,NONMETALLIC SP.....	1
					UC:A15,B15,H15	
3	PAOZZ	5330012658806	19207	12341211-3	SEAL,PLAIN 226.88 INCHES LONG.....	1
					UC:B16,H16	

END OF FIGURE



11—  
12  
and  
13

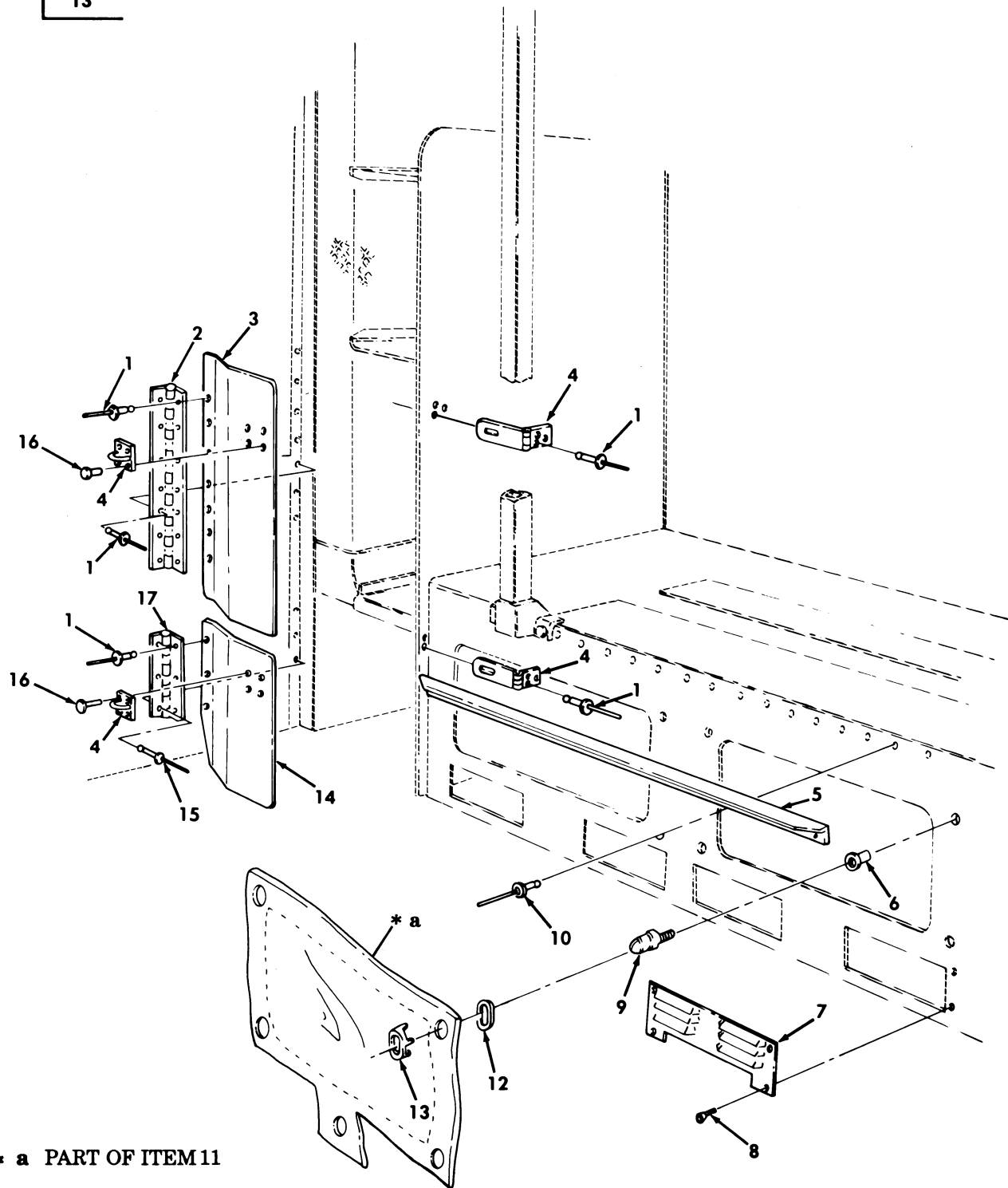

\* a PART OF ITEM 11

Figure 224. Medical Storage Doors, Lower Heater Louver, and Related Components, M997, M997A1, and M997A2 Ambulance.

SECTION II			TM9-2320-280-24P			
(1)	(2)	(3)	(4)	(5)	(6)	(7)
ITEM NO	SMR CODE	NSN	CAGEC	PART NUMBER	DESCRIPTION AND USABLE ON CODES(UC)	QTY
					GROUP 1801 BODY,CAB,HOOD,AND HULL ASSEMBLY	
					FIG. 224 MEDICAL STOWAGE DOORS,LOWER HEATER LOUVER,AND RELATED COMPONENTS ,M997,M997A1,AND M997A2 AMBULANCE	
1	PAOZZ	5320012596155	34623	5575936	RIVET,SOLID 3/16 X 7/16.....	16
					UOC:A15,B15,H15	
2	PFOZZ	5340010537128	96906	MS35823-7A	HINGE,BUTT UPPER,R.H.,14 INCHES LONG.....	1
					UOC:A15,B15,H15	
3	PFOZZ	2510012720536	19207	12341120	PANEL,BODY,VEHICULA UPPER,R.H.....	1
					UOC:A15,B15,H15	
4	PAOZZ	5340013105321	34623	5589918	HASP,HINGED.....	2
					UOC:A15,B15,H15	
5	PFOZZ	2540012761451	19207	12341113	SUPPORT,SEAT,VEHICU.....	2
					UOC:A15,B15,H15	
6	PAOZZ	5310012107935	03481	S10P196	NUT,PLAIN,BLIND RIV #10-32.....	10
					UOC:A15,B15,H15	
7	PFOZZ	2540012765935	21102	HV034186	VENTILATOR,AIR CIRC.....	4
					UOC:A15,B15,H15	
8	PAOZZ	5305000457603	96906	MS24625-42	SCREW,TAPPING #10-16 X 3/8.....	16
					UOC:A15,B15,H15	
9	PAOZZ	5305012823386	41024	12214139	SCREW ASSEMBLY,PANE #10-32.....	10
					UOC:A15,B15,H15	
10	PAOZZ	5320012734601	11815	CR-213-6-8	RIVET,BLIND 3/16 X 1/2.....	32
					UOC:A15,B15,H15	
11	PAOOO	2540012651137	17168	SF5592171	COVER,FITTED,VEHICU.....	2
					UOC:A15,B15,H15	
12	PAOZZ	5325003718108	13940	BS 78505	.CLINCH PLATE,TURNBU.....	5
					UOC:A15,B15,H15	
13	PAOZZ	5325002818643	61864	BS-78403	.SOCKET,TURNBUTTON F.....	5
					UOC:A15,B15,H15	
14	PFOZZ	5340012665708	19207	12341119	COVER,ACCESS LOWER,R.H.....	1
					UOC:A15,B15,H15	
15	PAOZZ	5320010849235	11815	CR-213-6-5	RIVET,BLIND 3/16.....	10
					UOC:A15,B15,H15	
16	PAOZZ	5320001177287	96906	MS20426AD6-7	RIVET,SOLID 3/16 X 7/16.....	8
					UOC:A15,B15,H15	
17	PAOZZ	5340012722732	34623	5589425	HINGE,BUTT 6 INCHES LONG.....	1
					UOC:A15,B15,H15	

END OF FIGURE

36 — 37

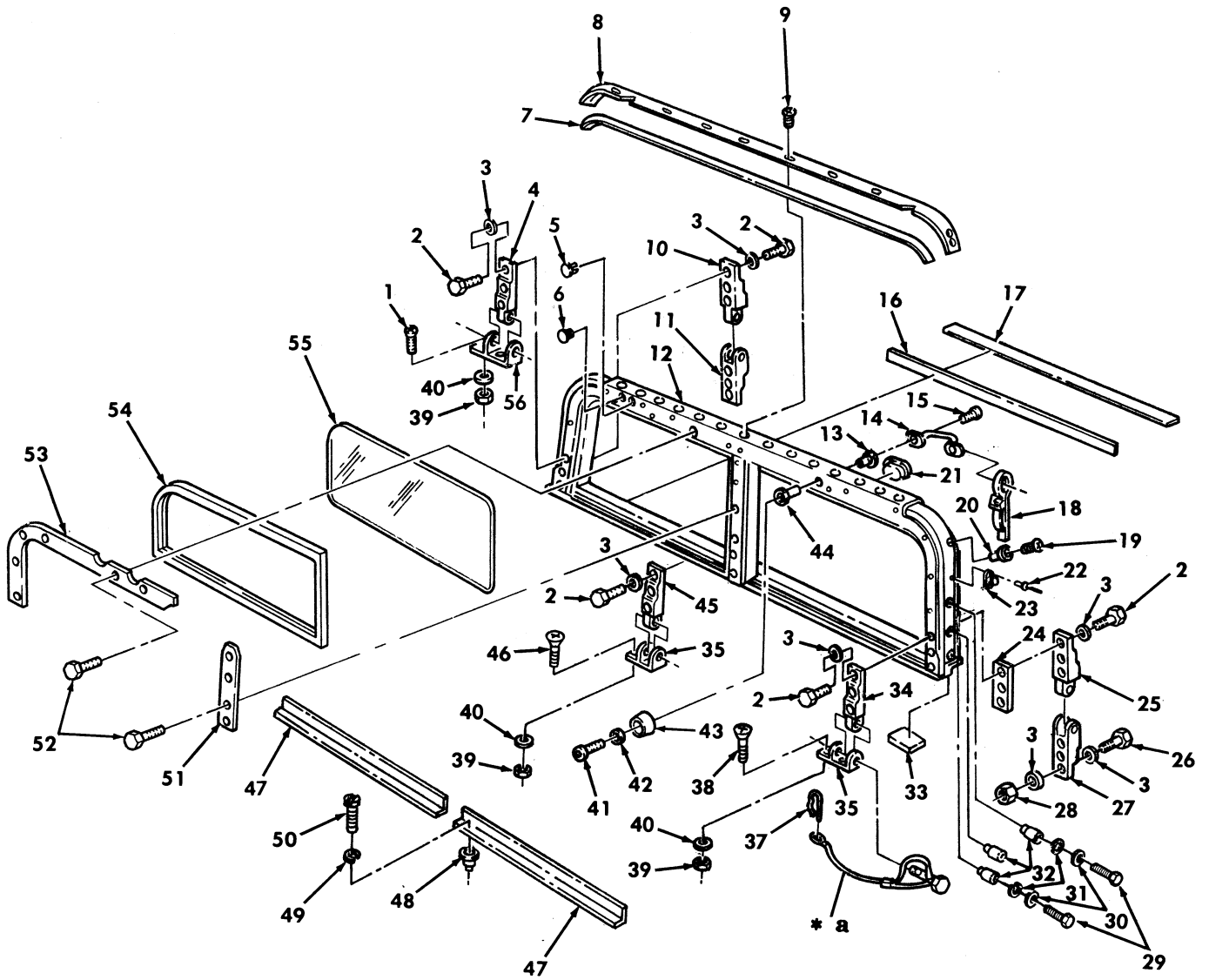

\* a PART OF ITEM 36

Figure 225. Windshield Assembly, Folddown.

SECTION II			TM9-2320-280-24P			
(1)	(2)	(3)	(4)	(5)	(6)	(7)
ITEM NO	SMR CODE	NSN	CAGEC	PART NUMBER	DESCRIPTION AND USABLE ON CODES(UC)	QTY
					GROUP 1802 FENDERS,RUNNING BOARDS WITH MOUNTING AND ATTACHING PARTS, OUTRIGGERS,WINDSHIELD,AND GLASS	
					FIG. 225 WINDSHIELD ASSEMBLY, FOLDDOWN	
1	PAOZZ	5305007637829	96906	MS51959-99	SCREW,MACHINE 5/16-18 X 1.25.....	4
					UOC:AVY,A13,A14,A20,BVY,B20,HVY,H13,H14,H20,H21,H28,NNN	
2	PAOZZ	5306002264828	80204	B1821BH031C113N	BOLT,MACHINE REAR,LOWER HINGE,5/16-18 X 1.125.....	15
					UOC:AVY,A13,A14,A20,BVY,B20,HVY,H13,H14,H20,H21,H28,NNN	
3	PAOZZ	5310011191024	24617	2436162	WASHER,FLAT REAR,LOWER HINGE,5/16..	27
					UOC:AVY,A13,A14,A20,BVY,B20,HVY,H13,H14,H20,H21,H28,NNN	
4	PAOZZ	5340012038608	34623	5585154	LEAF,BUTT HINGE FRONT R.H.....	1
					UOC:AVY,A13,A14,A20,BVY,B20,HVY,H13,H14,H20,H21,H28,NNN	
5	PAOZZ	5340011854959	52854	207-320401-00	BUTTON,PLUG.....	1
					UOC:AVY,A13,A14,A20,BVY,B20,HVY,H13,H14,H20,H21,H28,NNN	
6	PAOZZ	5340013327602	19207	12339661-1	BUTTON,PLUG.....	1
					UOC:AVY,A13,A14,A20,BVY,B20,HVY,H13,H14,H20,H21,H28,NNN	
7	MOOZZ		34623	5581366	SEAL MAKE FROM TAPE,P/N 4965,82 INCHES LONG.....	1
					UOC:AVY,A13,A14,A20,BVY,B20,HVY,H13,H14,H20,H21,H28,NNN	
8	PFOZZ	2540011965313	34623	5581367	FORMER,PILLAR FRONT.....	1
					UOC:AVY,A13,A14,A20,BVY,B20,HVY,H13,H14,H20,H21,H28,NNN	
9	PAOZZ	5305011394293	34623	G167084	SCREW,MACHINE..#10-24 X 1/2.....	13
					UOC:AVY,A13,A14,A20,BVY,B20,HVY,H13,H14,H20,H21,H28,NNN	
10	PAOZZ	5340011856997	19207	12338836-2	LEAF,BUTT HINGE R.H. FRONT.....	1
					UOC:AVY,A13,A14,A20,BVY,B20,HVY,H13,H14,H20,H21,H28,NNN	
11	PAOZZ	5340011867594	19207	12338834-2	LEAF,BUTT HINGE R.H.LOWER.....	1
					UOC:AVY,A13,A14,A20,BVY,B20,HVY,H13,H14,H20,H21,H28,NNN	
12	PFOZZ	2510014133360	19207	12446879	FRAME,WINDOW,VEHICU.....	1
					UOC:BVY,B20,NNN	
12	PFOZZ	2510012331141	19207	12339512	FRAME,WINDOW,VEHICU.....	1
					UOC:AVY,A13,A14,A20,HVY,H13,H14,H20,H21,H28	
13	PAOZZ	5310002693466	96906	MS27130-S26	NUT,PLAIN,BLIND RIV .190-32 X .641.	4
					UOC:AVY,A13,A14,A20,BVY,B20,HVY,H13,H14,H20,H21,H28,NNN	
14	PAOZZ	5340011918186	34623	5582608	HANDLE,BOW.....	2
					UOC:AVY,A13,A14,A20,BVY,B20,HVY,H13,H14,H20,H21,H28,NNN	

SECTION II			TM9-2320-280-24P			
(1)	(2)	(3)	(4)	(5)	(6)	(7)
ITEM NO	SMR CODE	NSN	CAGEC	PART NUMBER	DESCRIPTION AND USABLE ON CODES(UC)	QTY
15	PAOZZ	5305011850114	7X677	157166	SCREW #10-32 X 3/4..... UOC:AVY,A13,A14,A20,BVY,B20,HVY,H13, H14,H20,H21,H28,NNN	4
16	MOOZZ		34623	5596171	SEAL LOWER,MAKE FROM SEAL,P/N 68- 412121-1,81.50 INCHES LONG..... UOC:AVY,A13,A14,A20,BVY,B20,HVY,H13, H14,H20,H21,H28,NNN	1
17	MOOZZ		34623	SF5590706	SEAL LOWER,MAKE FROM SEAL,P/N 68- 412121-1,80.50 INCHES LONG..... UOC:AVY,A13,A14,A20,BVY,B20,HVY,H13, H14,H20,H21,H28,NNN	1
18	PAOZZ	5340011857024	19207	12338845	STRAP,WEBBING..... UOC:AVY,A13,A14,A20,BVY,B20,HVY,H13, H14,H20,H21,H28,NNN	2
19	PAOZZ	5305011858647	7X677	160057	SCREW,MACHINE #10-32 X 3/4..... UOC:AVY,A13,A14,A20,BVY,B20,HVY,H13, H14,H20,H21,H28,NNN	17
20	PFOZZ	5310011981723	19207	12339998-14	NUT,PLAIN,BLIND RIV #10-32..... UOC:AVY,A13,A14,A20,BVY,B20,HVY,H13, H14,H20,H21,H28,NNN	17
21	PAOZZ	5340011881018	19207	12338829	CAP-PLUG,PROTECTIVE..... UOC:AVY,A13,A14,A20,BVY,B20,HVY,H13, H14,H20,H21,H28,NNN	2
22	PFOZZ	5320010232529	81349	M24243/1-A404	RIVET,BLIND .125,.188,.250 GRIP.... UOC:AVY,A13,A14,A20,BVY,B20,HVY,H13, H14,H20,H21,H28,NNN	4
23	PFOZZ	5325008235999	13940	XB78323-05001	STUD,TURNBUTTON FAS..... UOC:AVY,A13,A14,A20,BVY,B20,HVY,H13, H14,H20,H21,H28,NNN	2
24	PAOZZ	5365012134239	34623	5585178	SPACER,PLATE..... UOC:AVY,A13,A14,A20,BVY,B20,HVY,H13, H14,H20,H21,H28,NNN	7
25	PAOZZ	5340011867593	19207	12338836-1	LEAF,BUTT HINGE L.H. FRONT AND R.H. REAR..... UOC:AVY,A13,A14,A20,BVY,B20,HVY,H13, H14,H20,H21,H28,NNN	1
26	PAOZZ	5306002264829	80204	B1821BH031C125N	BOLT,MACHINE REAR,LOWER HINGE,5/16- 18 X 1 1/4..... UOC:AVY,A13,A14,A20,BVY,B20,HVY,H13, H14,H20,H21,H28,NNN	6
27	PAOZZ	5340011856998	19207	12338834-1	LEAF,BUTT HINGE L.H.,LOWER..... UOC:AVY,A13,A14,A20,BVY,B20,HVY,H13, H14,H20,H21,H28,NNN	2
28	PAOZZ	5310008140673	96906	MS51943-33	NUT,SELF-LOCKING,HE REAR,LOWER,5/ 16-18..... UOC:AVY,A13,A14,A20,BVY,B20,HVY,H13, H14,H20,H21,H28,NNN	6
29	PAOZZ	5306002264827	80204	B1821BH031C100N	BOLT,MACHINE 5/16-18 X 1.00..... UOC:BVY,B20,NNN	2
30	PAOZZ	5310000814219	96906	MS27183-12	WASHER,FLAT 5/16..... UOC:BVY,B20,NNN	2
31	PAOZZ	5310004079566	96906	MS35338-45	WASHER,LOCK 5/16..... UOC:BVY,B20,NNN	2

SECTION II			TM9-2320-280-24P				(7)
(1)	(2)	(3)	(4)	(5)	(6)		(7)
ITEM	SMR			PART			
NO	CODE	NSN	CAGEC	NUMBER	DESCRIPTION AND USABLE ON CODES(UOC)	QTY	
32	PAOZZ	5310014133276	78276	ALS4-518-150	NUT,PLAIN,BLIND RIV.....	5	
					UOC:BVY,B20,NNN		
33	MOOZZ		34623	5596172	SEAL LOWER,MAKE FROM SEAL,P/N 68-412121-1,2.88 INCHES LONG.....	2	
					UOC:AVY,A13,A14,A20,BVY,B20,HVY,H13,H14,H20,H21,H28,NNN		
34	PAOZZ	2510011987413	19207	12338841-1	HINGE,WINDSHIELD UPPER,L.H.....	2	
					UOC:AVY,A13,A14,A20,BVY,B20,HVY,H13,H14,H20,H21,H28,NNN		
35	PAOZZ	5342011867382	19207	12338822-1	HINGE.....	2	
					UOC:AVY,A13,A14,A20,BVY,B20,HVY,H13,H14,H20,H21,H28,NNN		
36	PAOZZ	5315012052988	19207	12338813	PIN,STRAIGHT,HEADED.....	5	
					UOC:AVY,A13,A14,A20,BVY,B20,HVY,H13,H14,H20,H21,H28,NNN		
37	PAOZZ	5315011884490	46156	34403-35-1	.PIN.....	1	
					UOC:AVY,A13,A14,A20,BVY,B20,HVY,H13,H14,H20,H21,H28,NNN		
38	PAOZZ	5305014772824	24617	156471	SCREW,MACHINE.....	2	
					UOC:AVY,A13,A14,A20,BVY,B20,HVY,H13,H14,H20,H21,H28,NNN		
39	PAOZZ	5310012097702	7X677	9429048	NUT,PLAIN,HEXAGON.....	6	
					UOC:AVY,A13,A14,A20,BVY,B20,HVY,H13,H14,H20,H21,H28,NNN		
40	PAOZZ	5310011993440	7X677	9424258	WASHER,LOCK.....	6	
					UOC:AVY,A13,A14,A20,BVY,B20,HVY,H13,H14,H20,H21,H28,NNN		
41	PAOZZ	5305000712510	80204	B1821BH025C175N	SCREW,CAP,HEXAGON H 1/4-20 X 1-3/4.	2	
					UOC:AVY,A13,A14,A20,BVY,B20,HVY,H13,H14,H20,H21,H28,NNN		
42	PAOZZ	5310008094058	96906	MS27183-10	WASHER,FLAT.....	2	
					UOC:AVY,A13,A14,A20,BVY,B20,HVY,H13,H14,H20,H21,H28,NNN		
43	PAOZZ	5340011850404	19207	12338824	BUMPER,NONMETALLIC.....	2	
					UOC:AVY,A13,A14,A20,BVY,B20,HVY,H13,H14,H20,H21,H28,NNN		
44	PAOZZ	5310000068291	96906	MS27130-S32	NUT,PLAIN,BLIND RIV .3125-18 X .937	2	
					UOC:AVY,A13,A14,A20,BVY,B20,HVY,H13,H14,H20,H21,H28,NNN		
45	PAOZZ	5340011850401	19207	12338835	LEAF,BUTT HINGE.....	1	
					UOC:AVY,A13,A14,A20,BVY,B20,HVY,H13,H14,H20,H21,H28,NNN		
46	PAOZZ	5305009585253	80205	MS35190-306	SCREW,MACHINE 5/16-18 X 1.00.....	2	
					UOC:AVY,A13,A14,A20,BVY,B20,HVY,H13,H14,H20,NNN		
46	PAOZZ	5305009585469	80205	MS35190-305	SCREW,MACHINE.....	2	
					UOC:H21,H28		
47	PAOZZ	2510014110652	34623	12447029	FRAME,WINDOW,VEHICU.....	2	
					UOC:BVY,B20,NNN		
48	PAOZZ	5325014110066	78276	ALS4-1024-130	INSERT,SCREW THREAD.....	8	
					UOC:BVY,B20,NNN		
49	PAOZZ	5310009222017	72582	120217	WASHER,LOCK.....	8	
					UOC:BVY,B20,NNN		

SECTION II			TM9-2320-280-24P			
(1)	(2)	(3)	(4)	(5)	(6)	(7)
ITEM	SMR			PART		
NO	CODE	NSN	CAGEC	NUMBER	DESCRIPTION AND USABLE ON CODES(UC)	QTY
50	PAOZZ	5305002400194	96906	MS51849-76	SCREW,MACHINE #10-24 X 3/4.....	8
					UOC:BVY,B20,NNN	
51	PAOZZ	2590011883225	19207	12338843	MOLDING,METAL.....	1
					UOC:AVY,A13,A14,A20,BVY,B20,HVY,H13, H14,H20,H21,H28,NNN	
52	PAOZZ	5305013615353	24617	9414241	SCREW,TAPPING.....	16
					UOC:AVY,A13,A14,A20,BVY,B20,HVY,H13, H14,H20,H21,H28,NNN	
53	PAOZZ	2590011891067	19207	12338852	MOLDING,METAL.....	2
					UOC:AVY,A13,A14,A20,BVY,B20,HVY,H13, H14,H20,H21,H28,NNN	
54	PAOZZ	5330012095997	19207	12338860	SEAL,NONMETALLIC ST.....	2
					UOC:AVY,A13,A14,A20,BVY,B20,HVY,H13, H14,H20,H21,H28,NNN	
55	PAOZZ	9340011853757	19207	12339514	GLASS,LAMINATED.....	2
					UOC:AVY,A13,A14,A20,BVY,B20,HVY,H13, H14,H20,H21,H28,NNN	
56	PAOZZ	5342011850116	19207	12338822-2	HINGE,WIND SHIELD R.H.,LOWER.....	1
					UOC:AVY,A13,A14,A20,BVY,B20,HVY,H13, H14,H20,H21,H28,NNN	

END OF FIGURE

19-20

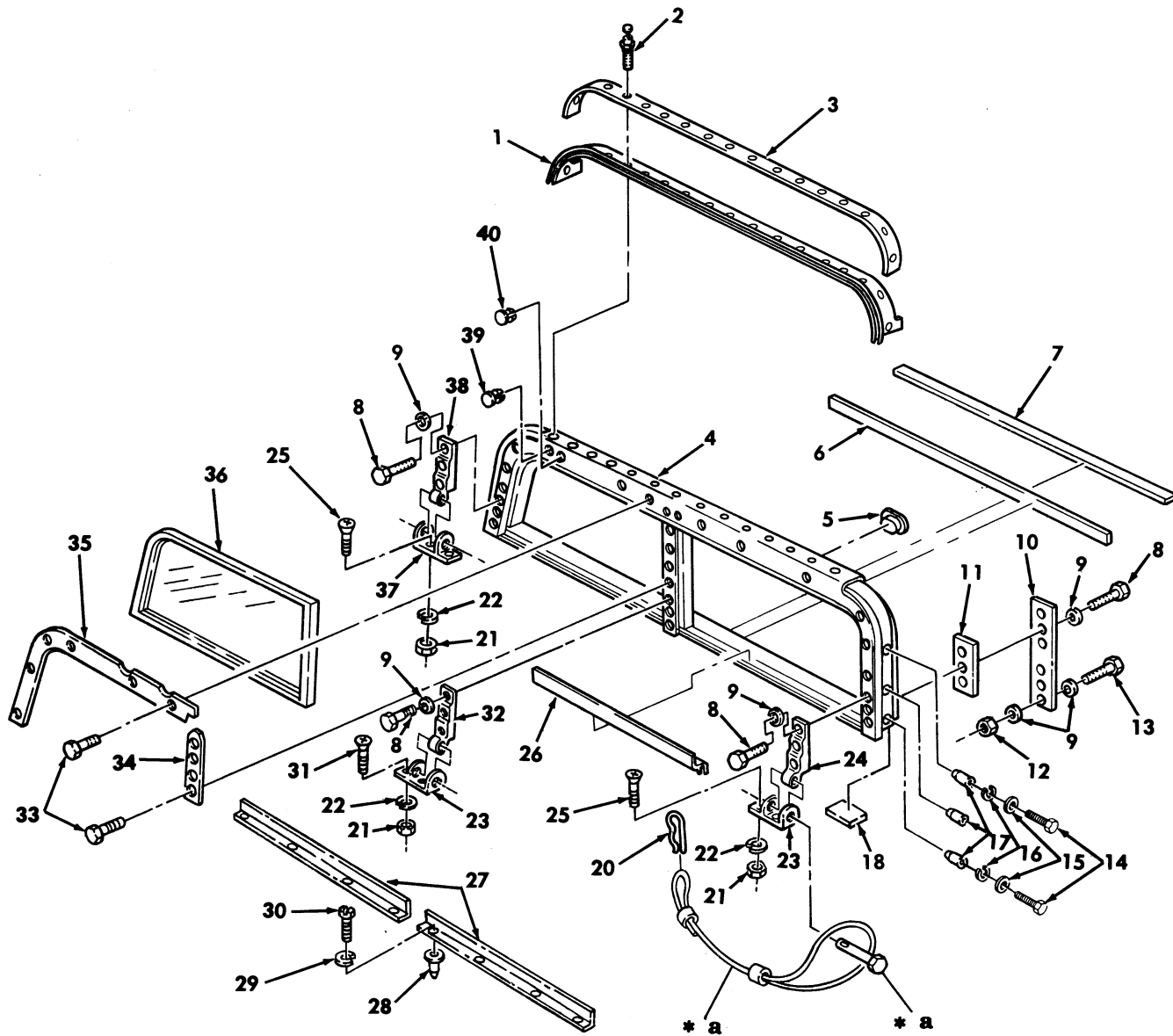

\* a PART OF ITEM 19

Figure 226. Windshield Assembly, Ballistic.



SECTION II			TM9-2320-280-24P			
(1)	(2)	(3)	(4)	(5)	(6)	(7)
ITEM	SMR			PART		
NO	CODE	NSN	CAGEC	NUMBER	DESCRIPTION AND USABLE ON CODES(UOC)	QTY
					GROUP 1802 FENDERS,RUNNING BOARDS WITH MOUNTING AND ATTACHING PARTS, OUTRIGGERS,WINDSHIELD,AND GLASS	
					FIG. 226 WINDSHIELD ASSEMBLY, BALLISTIC	
1	PAFZZ	2540012468289	19207	12338810	SEAL ASSEMBLY,WINSH UPPER.....	1
					UOC:A11,A24,A25,A26,B17,B18,B24,B25, C17,H11,H17,H18,H24,H25,H26,H27,MMM	
2	PAFZZ	5320012597423	11815	CR-213-4-5	RIVET,BLIND UPPER,1/8 DIA.....	27
					UOC:A11,A24,A25,A26,B17,B18,B24,B25, C17,H11,H17,H18,H24,H25,H26,H27,MMM	
3	PAFZZ	2590012468288	19207	12338818	BEZEL,AUTOMOTIVE TR UPPER.....	1
					UOC:A11,A24,A25,A26,B17,B18,B24,B25, C17,H11,H17,H18,H24,H25,H26,H27,MMM	
4	PFFZZ	2510012477968	19207	12340836	FRAME,WINDOW,VEHICU.....	1
					UOC:A15,H16	
4	PFFZZ	2510014147846	34623	12446878	FRAME,WINDOW,VEHICU.....	1
					UOC:B24,B25,C17	
4	PFFZZ	2510014133259	34623	12446880	FRAME,WINDOW,VEHICU.....	1
					UOC:B15,B16	
4	PFFZZ	2510012337767	19207	12339513	FRAME,WINDOW,VEHICU.....	1
					UOC:A11,A24,A25,A26,A27,B17,B18,H11, H17,H18,H24,H25,H26,H27,MMM	
5	PAOZZ	5340011881018	19207	12338829	CAP-PLUG,PROTECTIVE.....	2
					UOC:A11,A15,A24,A25,A26,A27,B15,B16, B17,B18,B24,B25,C17,H11,H15,H16,H17, H18,H24,H25,H26,H27,MMM	
6	MFOZZ		19207	12338807-4	SEAL LOWER,MAKE FROM SEAL,P/N 68- 412121-2,81.50 INCHES LONG.....	1
					UOC:A11,A15,A24,A25,A26,A27,B15,B16, B17,B18,B24,B25,C17,H11,H15,H16,H17, H18,H24,H25,H26,H27,MMM	
7	MFOZZ		34623	SF5590706	SEAL LOWER,MAKE FROM SEAL,P/N 68- 412121-1,80.5 INCHES LONG.....	1
					UOC:A11,A15,A24,A25,A26,A27,B15,B16, B17,B18,B24,B25,C17,H11,H15,H16,MMM	
8	PAFZZ	5306002264829	80204	B1821BH031C125N	BOLT,MACHINE 5/16-18 X 1.25.....	6
					UOC:A11,A15,A24,A25,A26,A27,B15,B16, B17,B18,B24,B25,C17,H11,H15,H16,H17, H18,H24,H25,H26,H27,MMM	
9	PAFZZ	5310011191024	24617	2436162	WASHER,FLAT 5/16.....	27
					UOC:A11,A15,A24,A25,A26,A27,B15,B16, B17,B18,B24,B25,C17,H11,H15,H16,H17, H18,H24,H25,H26,H27,MMM	
10	PFFZZ	5340012477912	19207	12338833	BRACKET,MOUNTING REAR.....	2
					UOC:A11,A15,A24,A25,A26,A27,B15,B16, B17,B18,B24,B25,C17,H11,H15,H16,H17, H18,H24,H25,H26,H27,MMM	
11	PFFZZ	5365012134239	34623	5585178	SPACER,PLATE.....	6
					UOC:A11,A15,A24,A25,A26,A27,B15,B16, B17,B18,B24,B25,C17,H11,H15,H16,H17,	

SECTION II			TM9-2320-280-24P			
(1)	(2)	(3)	(4)	(5)	(6)	(7)
ITEM NO	SMR CODE	NSN	CAGEC	PART NUMBER	DESCRIPTION AND USABLE ON CODES(UC)	QTY
12	PAFZZ	5310008140673	96906	MS51943-33	H18,H24,H25,H26,H27,MMM NUT,SELF-LOCKING,HE LOWER,5/16-18..	6
					UOC:A11,A15,A24,A25,A26,A27,B15,B16, B17,B18,B24,B25,C17,H11,H15,H16,H17, H18,H24,H25,H26,H27,MMM	
13	PAFZZ	5306002264828	80204	B1821BH031C113N	BOLT,MACHINE LOWER,5/16-18 X 1.125.	15
					UOC:A11,A15,A24,A25,A26,A27,B15,B16, B17,B18,B24,B25,C17,H11,H15,H16,H17, H18,H24,H25,H26,H27,MMM	
14	PAFZZ	5306002264827	80204	B1821BH031C100N	BOLT,MACHINE 5/16-18 X 1.00.....	2
					UOC:B15,B24,B25,C17	
15	PAFZZ	5310000814219	96906	MS27183-12	WASHER,FLAT 5/16.....	2
					UOC:B15,B24,B25,C17	
16	PAFZZ	5310004079566	96906	MS35338-45	WASHER,LOCK 5/16.....	2
					UOC:B15,B24,B25,C17	
17	PAFZZ	5310014133276	78276	ALS4-518-150	NUT,PLAIN,BLIND RIV.....	5
					UOC:A11,A15,A24,A25,A26,A27,B15,B16, B17,B18,B24,B25,C17,H11,H15,H16,H17, H18,H24,H25,H26,H27,MMM	
18	MFFZZ		34623	5596172	SEAL LOWER,MAKE FROM SEAL,P/N 68- 412121-2,2.88 INCHES LONG.....	2
					UOC:A11,A15,A24,A25,A26,A27,B15,B16, B17,B18,B24,B25,C17,H11,H15,H16,H17, H18,H24,H25,H26,H27,MMM	
19	PAOZZ	5315012052988	19207	12338813	PIN,STRAIGHT,HEADED.....	3
					UOC:A11,A15,A24,A25,A26,A27,B15,B16, B17,B18,B24,B25,C17,H11,H15,H16,H17, H18,H24,H25,H26,H27,MMM	
20	PAOZZ	5315011884490	19207	12339401	.PIN.....	1
					UOC:A11,A15,A24,A25,A26,A27,B15,B16, B17,B18,B24,B25,C17,H11,H15,H16,H17, H18,H24,H25,H26,H27,MMM	
21	PAFZZ	5310008807744	96906	MS51967-5	NUT,PLAIN,HEXAGON LOWER,5/16-18....	6
					UOC:A11,A15,A24,A25,A26,A27,B15,B16, B17,B18,B24,B25,C17,H11,H15,H16,H17, H18,H24,H25,H26,H27,MMM	
22	PAFZZ	5310012538957	34623	5592927	WASHER,LOCK LOWER,5/16.....	6
					UOC:A11,A15,A24,A25,A26,A27,B15,B16, B17,B18,B24,B25,C17,H11,H15,H16,H17, H18,H24,H25,H26,H27,MMM	
23	PFFZZ	5342011867382	19207	12338822-1	HINGE L.H. LOWER AND CENTER.....	2
					UOC:A11,A15,A24,A25,A26,A27,B15,B16, B17,B18,B24,B25,C17,H11,H15,H16,H17, H18,H24,H25,H26,H27,MMM	
24	PFFZZ	2510011987413	19207	12338841-1	HINGE,WINDSHIELD UPPER,L.H.....	1
					UOC:A11,A15,A24,A25,A26,A27,B15,B16, B17,B18,B24,B25,C17,H11,H15,H16,H17, H18,H24,H25,H26,H27,MMM	
25	PAFZZ	5305009585253	80205	MS35190-306	SCREW,MACHINE 5/16-18 X 1.00.....	4
					UOC:A15,B15,B16,H15,H16	
25	PAFZZ	5305009585254	80205	MS35190-307	SCREW,MACHINE 5/16-18 X 1-1/4.....	4
					UOC:A11,A24,A25,A26,A27,B17,B18,B24, B25,C17,H11,H17,H18,H24,H25,H26,H27,	

SECTION II			TM9-2320-280-24P			
(1)	(2)	(3)	(4)	(5)	(6)	(7)
ITEM	SMR			PART		
NO	CODE	NSN	CAGEC	NUMBER	DESCRIPTION AND USABLE ON CODES(UOC)	QTY
26	PFFZZ	2590012096043	19207	12338819	MMM BEZEL,AUTOMOTIVE TR LOWER.....	2
					UOC:A24,A25,A26,A27,B24,B25,H24,H25, H26,H27	
27	PAFZZ	2510014110652	34623	12447029	FRAME,WINDOW,VEHICU.....	2
					UOC:B15,B24,B25,C17	
28	PAFZZ	5325014110066	78276	ALS4-1024-130	INSERT,SCREW THREAD.....	8
					UOC:B15,B24,B25,C17	
29	PAFZZ	5310009222017	72582	120217	WASHER,LOCK #10.....	8
					UOC:B15,B24,B25,C17	
30	PAFZZ	5305002400194	96906	MS51849-76	SCREW,MACHINE.....	8
					UOC:B15,B24,B25,C17	
31	PAFZZ	5305009585469	80205	MS35190-305	SCREW,MACHINE 5/16-18 X 7/8.....	2
					UOC:A25,A26,B25,H25,H26	
31	PAFZZ	5305009585254	80205	MS35190-307	SCREW,MACHINE 5/16-18 X 1 1/4.....	2
					UOC:A15,B15,B16,H15,H16	
31	PAFZZ	5305009585253	80205	MS35190-306	SCREW,MACHINE 5/16-18 X 1.00.....	2
					UOC:A11,A24,A27,B17,B18,B24,C17,H11, H17,H18,H24,H27,MMM	
32	PFFZZ	5340011850401	19207	12338835	LEAF,BUTT HINGE CENTER,UPPER.....	1
					UOC:A11,A15,A24,A25,A26,A27,B15,B16, B17,B18,B24,B25,C17,H11,H15,H16,H17, H18,H24,H25,H26,H27,MMM	
33	PAOZZ	5305012645809	19207	12342499-2	SCREW,TAPPING THREA #10-32 X .62...	16
					UOC:A11,A15,A24,A25,A26,A27,B15,B16, B17,B18,B24,B25,C17,H11,H15,H16,H17, H18,H24,H25,H26,H27,MMM	
34	PFOZZ	2590011883225	34623	5581260	MOLDING,METAL CENTER,BASIC.....	1
					UOC:A11,A15,B15,B16,B17,B18,C17,H11, H15,H16,H17,H18,MMM	
34	PFOZZ	2590012096041	19207	12338862	BEZEL,AUTOMOTIVE TR CENTER, BALLISTIC.....	1
					UOC:A24,A25,A26,A27,B24,B25,H24,H25, H26,H27	
35	PFOZZ	2590011891067	19207	12338852	MOLDING,METAL UPPER,BASIC.....	2
					UOC:A11,A15,B15,B16,B17,B18,C17,H11, H15,H16,H17,H18,MMM	
35	PFOZZ	2540012166320	19207	12338851-1	MOLDING,METAL L.H.,SUPPLEMENTAL....	1
					UOC:A24,A25,A26,A27,B24,B25,H24,H25, H26,H27	
35	PFOZZ	2590012096042	19207	12338851-2	MOLDING,METAL R.H.,SUPPLEMENTAL....	1
					UOC:A24,A25,A26,A27,B24,B25,H24,H25, H26,H27	
36	PAOZZ	2510012892233	19207	12339509	WINDOW,VEHICULAR L.H.,BASIC.....	1
					UOC:A11,A15,B15,B16,B17,B18,C17,H11, H15,H16,H17,H18,MMM	
36	PAOZZ	2510012898258	19207	12339506	WINDOW,VEHICULAR R.H.,BASIC.....	1
					UOC:A11,A15,B15,B16,B17,B18,C17,H11, H15,H16,H17,H18,MMM	
36	PAOZZ	2510012898259	19207	12339508	WINDOW,VEHICULAR L.H.,SUPPLEMENTAL..	1
					UOC:A24,A25,A26,A27,B24,B25,H24,H25, H26,H27	
36	PAOZZ	2510012898260	19207	12339507	WINDOW,VEHICULAR R.H.,SUPPLEMENTAL..	1

SECTION II			TM9-2320-280-24P			
(1)	(2)	(3)	(4)	(5)	(6)	(7)
ITEM	SMR			PART		
NO	CODE	NSN	CAGEC	NUMBER	DESCRIPTION AND USABLE ON CODES(UC)	QTY
37	PFFZZ	5342011850116	19207	12338822-2	UOC:A24,A25,A26,A27,B24,B25,H24,H25, H26,H27 HINGE,WIND SHIELD LOWER,R.H.....	1
38	PAFZZ	5340012038608	34623	5585154	UOC:A11,A15,A24,A25,A26,A27,B15,B16, B17,B18,B24,B25,C17,H11,H15,H16,H17, H18,H24,H25,H26,H27,MMM LEAF,BUTT HINGE UPPER,R.H.....	1
39	PAOZZ	5340013327602	19207	12339661-1	UOC:A11,A15,A24,A25,A26,A27,B15,B16, B17,B18,B24,B25,C17,H11,H15,H16,H17, H18,H24,H25,H26,H27,MMM BUTTON,PLUG.....	1
40	PAOZZ	5340011854959	52854	207-320401-00	UOC:A11,A15,A24,A25,A26,A27,B15,B16, B17,B18,B24,B25,C17,H11,H15,H16,H17, H18,H24,H25,H26,H27,MMM BUTTON,PLUG.....	2

END OF FIGURE

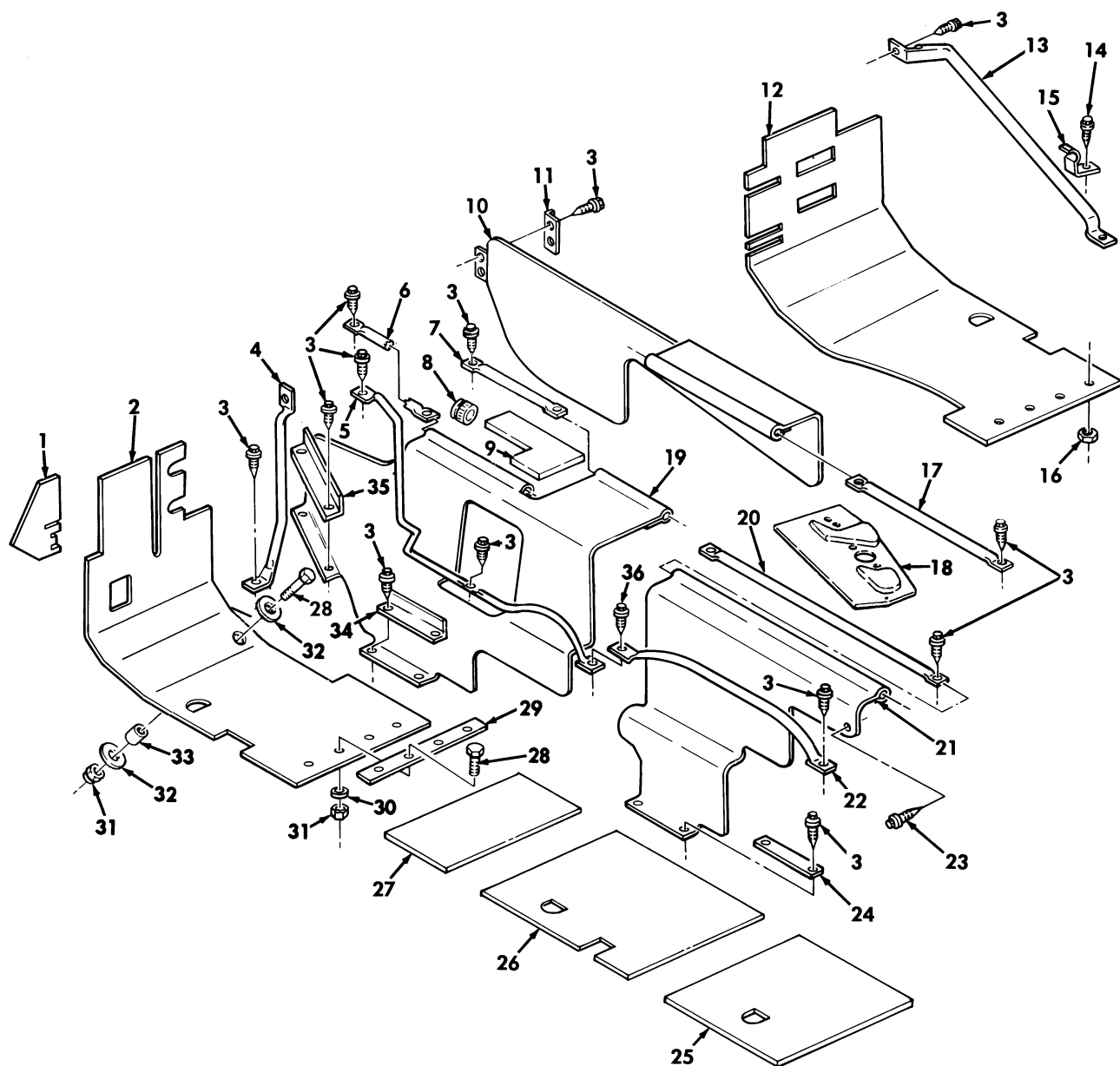

Figure 227. Interior Tunnel, Cowl, Floor Insulation, Mounting Components (Foam), and Exterior Insulation (Sheet 1 of 2).

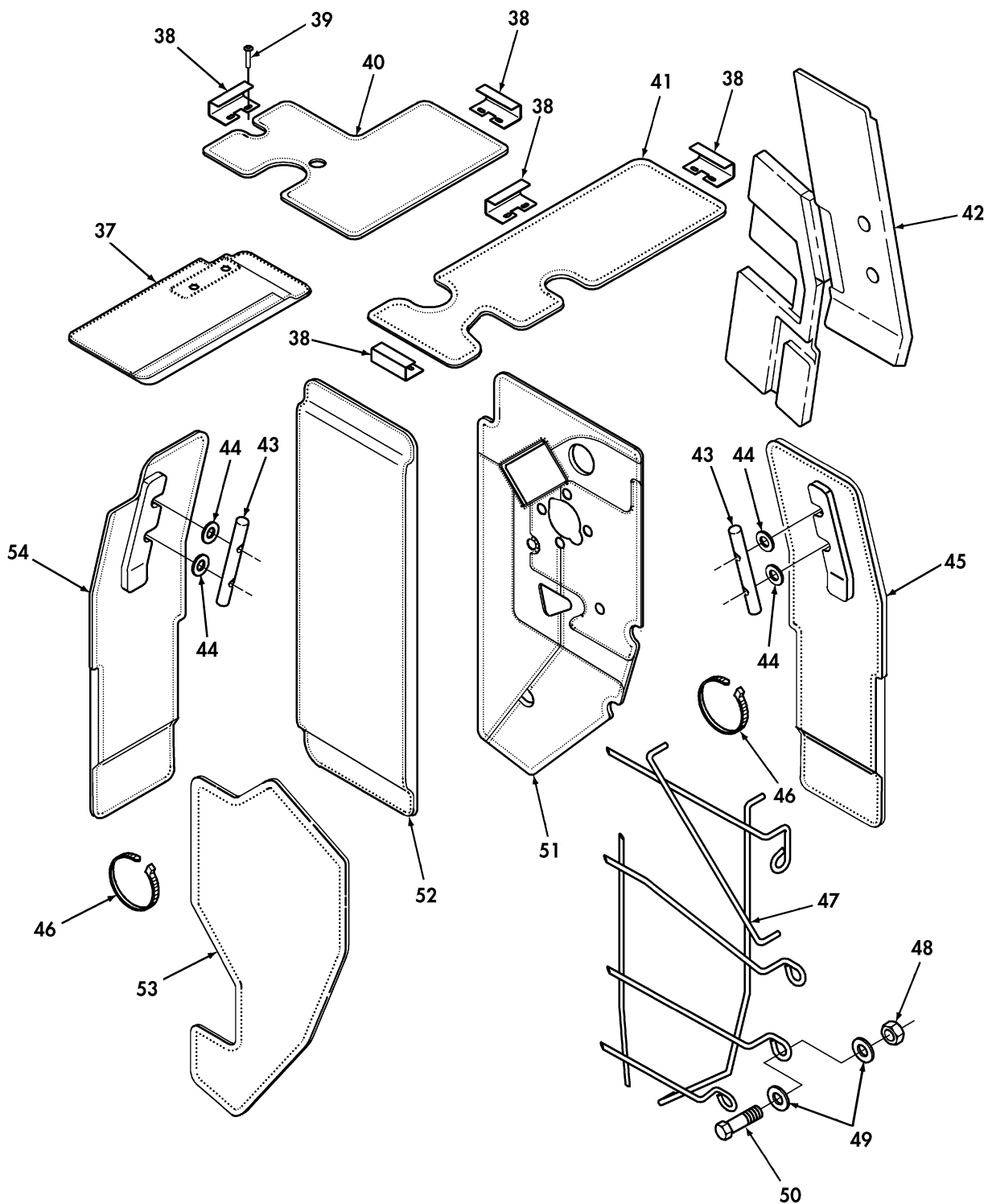

Figure 227. Interior Tunnel, Cowl, Floor Insulation, Mounting Components (Foam), and Exterior Insulation (Sheet 2 of 2).

SECTION II			TM9-2320-280-24P			
(1)	(2)	(3)	(4)	(5)	(6)	(7)
ITEM NO	SMR CODE	NSN	CAGEC	PART NUMBER	DESCRIPTION AND USABLE ON CODES(UOC)	QTY
GROUP 1805 FLOORS AND SUBFLOORS						
FIG. 227 INTERIOR TUNNEL,COWL,FLOOR INSULATION,MOUNTING COMPONENTS (FOAM),AND EXTERIOR INSULATION						
1	PAOZZ	2510012507597	19207	12338830	INSULATION PANEL,VE OUTER,UPPER,LH.	1
2	PAOZZ	2510012507596	19207	12339907	INSULATION PANEL,VE FRONT,FLOOR,LH.	1
UOC:HVY,H11,H13,H14,H15,H16,H17,H18,H20,H21,H24,H25,H26,H27,H28,MMM						
2	PAOZZ	2540013835232	9C234	12446700	INSULATION,THERMAL, FRONT,FLOOR,LH.	1
UOC:AVY,A11,A13,A14,A15,A20,A24,A25,A26,A27,BVY,B15,B16,B17,B18,B20,B24,B25,C17,NNN						
3	PAOZZ	5305012596322	34623	12342499-1	SCREW,MACHINE #10-32 X 1/2.....	25
UOC:AVY,A15,BVY,B15,B16,HVY,H15,H16,H21,H28,NNN						
3	PAOZZ	5305012596322	34623	12342499-1	SCREW,MACHINE #10-32 X 1/2.....	20
UOC:A11,A13,A14,A20,A24,A25,A26,A27,B17,B18,B20,B24,B25,C17,H11,H13,H14,H17,H18,H20,H24,H25,H26,H27,MMM						
4	PFOZZ	4710012516103	34623	5594002	TUBE,BENT,METALLIC FRONT,LH.....	1
5	PFOZZ	4710012513073	19207	12340828	TUBE,BENT,METALLIC INTERMEDIATE,LH.	1
6	PFOZZ	2590012513071	19207	12339015-2	RETAINER,INSULATION UPPER FRONT,LH.	1
7	PFOZZ	2590012513069	19207	12339015-3	RETAINER,INSULATION UPPER REAR,LH..	1
8	PAOZZ	5340012031980	28520	2683	CAP-PLUG,PROTECTIVE.....	2
9	PAOZZ	2590013065881	34623	12340824	PAD,CUSHIONING UPPER FRONT,L.H.....	1
10	PAOZZ	2510013357363	19207	12342455	INSULATION PANEL,VE SIDE,R.H.....	1
UOC:AVY,A11,A13,A14,A20,A24,A25,A26,A27,B16,B17,B18,B20,B24,B25,C17,H11,H13,H14,H16,H17,H18,H20,H24,H25,H26,H27,H28,MMM						
10	PAOZZ	2510012524466	34623	SF-5595841	INSULATION PANEL,VE SIDE,RH.....	1
UOC:A15,B15,H15						
11	PFOZZ	2590012627707	34623	5594076	MOLDING,METAL FRONT,RH.....	2
12	PAOZZ	2510012091881	34623	12339908	INSULATION BLANKET, FRONT FLOOR,RH.	1
13	PFOZZ	4710012547272	19207	12339018	TUBE,BENT,METALLIC.....	1
14	PAOZZ	5305000593659	96906	MS51958-63	SCREW,MACHINE #10-32 X 1/2.....	1
15	PAOZZ	5340012666398	19207	12339438	CLIP,RETAINING R.H.....	1
16	PAOZZ	5310001249265	24617	271169	NUT,PLAIN,ASSEMBLED #10-32.....	2
17	PFOZZ	2590012513069	19207	12339015-3	RETAINER,INSULATION UPPER,RH.....	1
UOC:A15,B15,H15						
17	PFOZZ	2590012513070	19207	12339015-1	RETAINER,INSULATION UPPER,RH.....	1
UOC:AVY,A11,A13,A14,A20,A24,A25,A26,A27,B16,B17,B18,HVY,H11,H13,H14,H16,H17,H18,H20,H21,H24,H25,H26,H27,H28,MMM						
18	PAOZZ	2510014218067	34623	12340823	INSULATION PANEL,VE FRONT,R.H.....	1
19	PAOZZ	2510012518548	19207	12339044	INSULATION BLANKET, FRONT,LH, USBL EFF 1 THRU 46161.....	1
UOC:H11,H13,H14,H15,H16,H17,H18,H20,H21,H24,H25,H26,H27,H28,MMM						
19	PAOZA	2540014611129	19207	12446961	INSULATION,THERMAL, USBL EFF 46162	1

SECTION II			TM9-2320-280-24P		(6)	(7)
(1)	(2)	(3)	(4)	(5)		
ITEM	SMR			PART		
NO	CODE	NSN	CAGEC	NUMBER	DESCRIPTION AND USABLE ON CODES(UC)	QTY
					AND ABOVE.....	
					UOC:AVY,A11,A13,A14,A20,A24,A25,A26,A27,BVY,B15,B16,B17,B18,B20,B24,B25,C17,HVY,H11,H13,H14,NNN	
20	PFOZZ	2590012513068	34623	12339015-4	RETAINER,INSULATION UPPER REAR,LH..	1
					UOC:AVY,A11,A13,A14,A20,A24,A25,A26,A27,B16,B17,B18,HVY,H11,H13,H14,H16,H17,H18,H20,H21,H24,H25,H26,H27,H28,MMM	
21	PAOZZ	2510012519995	19207	12339039	INSULATION PANEL,VE INTERMEDIATE REAR,LH.....	1
					UOC:AVY,A11,A13,A20,A24,A25,A26,A27,B17,B18,HVY,H11,H13,H17,H18,H20,H24,H25,H26,H27,H28,MMM	
22	PFOZZ	4710012513075	34623	5593947	TUBE,BENT,METALLIC INTERMEDIATE REAR,LH.....	1
					UOC:AVY,A11,A13,A14,A20,A24,A25,A26,A27,B17,B18,HVY,H11,H13,H14,H20,H21,H24,H25,H26,H27,H28,MMM	
23	PAOZZ	5305012707225	19207	12341822	SCREW,TAPPING THREA #10-16 X 1.00..	32
					UOC:AVY,A11,A13,A14,A20,A24,A25,A26,A27,B17,B18,HVY,H11,H13,H14,H17,H18,H20,H21,H24,H25,H26,H27,H28,MMM	
24	PFOZZ	2590012616851	34623	5594077	BEZEL,AUTOMOTIVE TR LOWER REAR,LH..	1
					UOC:A11,A13,A14,A15,A20,A24,A25,A26,A27,BVY,B15,B16,B17,B18,B20,B24,B25,C17,HVY,H11,H13,H14,H27,H28,MMM,NNN	
25	PAOZZ	2510012507595	24825	IF-3	INSULATION PANEL,VE L.H. AND R.H. REAR SEAT BASE.....	2
					UOC:AVY,A11,A13,A14,A20,A24,A25,A26,A27,B17,B18,H11,H13,H14,H17,H18,H20,H24,H25,H26,H27,MMM	
26	PAOZZ	2540013841012	19207	12446701	INSULATION,THERMAL, REAR,LH.....	1
					UOC:A11,A13,A14,A20,A24,A25,A26,A27,B17,B18,B20,B24,B25,C17	
26	PAOZZ	2510012507593	19207	12339019	INSULATION PANEL,VE REAR,RH.....	1
					UOC:A11,A13,A14,A20,A24,A25,A26,A27,B17,B18,B20,H11,H13,H17,H18,H20,H24,H25,H26,H27,MMM	
26	PAOZZ	2510012507594	24825	I F-5	INSULATION PANEL,VE REAR,LH.....	1
					UOC:H11,H13,H14,H17,H18,H20,H24,H25,H26,H27,MMM	
27	PAOZZ	2510013693230	19207	12339021	INSULATION PANEL,VE L.H.....	1
					UOC:HVY,H11,H13,H14,H15,H16,H17,H18,H20,H21,H24,H25,H26,H27,H28,MMM	
27	PAOZZ	2540013841028	19207	12446702	INSULATION,THERMAL, DRIVERS SEAT FLOOR.....	1
					UOC:AVY,A11,A13,A14,A15,A20,A24,A25,A26,A27,BVY,B15,B16,B17,B18,B20,B24,B25,C17,NNN	
28	PAOZZ	5305002253843	80204	B1821BH025C100N	SCREW,CAP,HEXAGON H 1/4-20 X 1.00..	9
29	PFOZZ	2590012633254	34623	5591713	BEZEL,AUTOMOTIVE TR COWL FLOOR,R.H.	1
29	PFOZZ	2590012627706	34623	5591712	MOLDING,METAL COWL FLOOR,L.H.....	1



SECTION II			TM9-2320-280-24P			
(1)	(2)	(3)	(4)	(5)	(6)	(7)
ITEM	SMR			PART		
NO	CODE	NSN	CAGEC	NUMBER	DESCRIPTION AND USABLE ON CODES(UC)	QTY
30	PAOZZ	5310008094058	96906	MS27183-10	WASHER, FLAT 1/4.....	8
31	PAOZZ	5310014326727	24617	9419471	NUT, SELF-LOCKING, HE 1/4-20.....	9
32	PAOZZ	5310011992293	7X677	9421394	WASHER, FLAT.....	2
33	PAOZZ	5365014772843	19207	12341640	SPACER, STRAIGHT.....	1
34	PAOZZ	5340012875825	19207	12341891	BRACKET, ANGLE.....	2
35	PFOZZ	5340012875825	34623	5598103	BRACKET, ANGLE L.H.....	1
36	PAOZZ	5305012645809	19207	12342499-2	SCREW, TAPPING THREA #10-32 X .62... UOC:AVY, A13, A14, A20, A24, A25, A26, A27, B17, B18, B20, B24, B25, C17, HVY, H11, H13, H14, H17, H18, H20, H24, H25, H26, H27, MMM	1
37	PAOZZ	2540014736304	19207	12446846	INSULATION, THERMAL, ..... UOC:H11, H13, H14, H17, H18, H20, H24, H25, H26, H27, MMM	1
38	PAOZZ	5340014790211	19207	12446858	BRACKET, MULTIPLE AN..... UOC:H11, H13, H14, H17, H18, H20, H24, H25, H26, H27, MMM	5
39	PAOZZ	5320011357319	11815	CR3213-6-3	RIVET, BLIND.....	10
40	PAOZZ	2540014738310	19207	12446853	INSULATION, THERMAL, ..... UOC:H11, H13, H14, H17, H18, H20, H24, H25, H26, H27, MMM	1
41	PAOZZ	2540014737107	19207	12446854	INSULATION, THERMAL, ..... UOC:H11, H13, H14, H17, H18, H20, H24, H25, H26, H27, MMM	1
42	PAOZZ	2540014737521	19207	12446847	INSULATION, THERMAL, ..... UOC:H11, H13, H14, H17, H18, H20, H24, H25, H26, H27, MMM	1
43	PAOZZ	5315014733682	19207	12446857	PIN, STRAIGHT, HEADLE..... UOC:H11, H13, H14, H17, H18, H20, H24, H25, H26, H27, MMM	2
44	PAOZZ		24617	9417497	WASHER, FLAT..... UOC:H11, H13, H14, H17, H18, H20, H24, H25, H26, H27, MMM	4
45	PAOZZ	2540014737544	19207	12446850	INSULATION, THERMAL, ..... UOC:H11, H13, H14, H17, H18, H20, H24, H25, H26, H27, MMM	1
46	PAOZZ	5975014753442	24617	11504726	STRAP, TIE-DOWN ELEC..... UOC:H11, H13, H14, H17, H18, H20, H24, H25, H26, H27, MMM	2
47	PAOZZ	2510014738204	19207	12446856	RETAINER ASSY, COWL..... UOC:H11, H13, H14, H17, H18, H20, H24, H25, H26, H27, MMM	1
48	PAOZZ	5310014618043	24617	9411807	NUT, SELF-LOCKING, EX..... UOC:H11, H13, H14, H17, H18, H20, H24, H25, H26, H27, MMM	4
49	PAOZZ	5310000145850	96906	MS27183-42	WASHER, FLAT..... UOC:H11, H13, H14, H17, H18, H20, H24, H25, H26, H27, MMM	4
50	PAOZZ	5305002406541	96906	MS51849-79	SCREW, MACHINE..... UOC:H11, H13, H14, H17, H18, H20, H24, H25, H26, H27, MMM	4
51	PAOZZ	2540014754708	19207	12446852	INSULATION, THERMAL, ..... UOC:H11, H13, H14, H17, H18, H20, H24, H25, H26, H27, MMM	1

SECTION II			TM9-2320-280-24P			
(1)	(2)	(3)	(4)	(5)	(6)	(7)
ITEM	SMR			PART		
NO	CODE	NSN	CAGEC	NUMBER	DESCRIPTION AND USABLE ON CODES(UC)	QTY
52	PAOZZ	2540014737553	19207	12446848	UOC:H11,H13,H14,H17,H18,H20,H24,H25, H26,H27,MMM INSULATION,THERMAL,.....	1
53	PAOZZ	2540014737959	19207	12446851	UOC:H11,H13,H14,H17,H18,H20,H24,H25, H26,H27,MMM INSULATION,THERMAL,.....	1
54	PAOZZ	2540014738050	19207	12446849	UOC:H11,H13,H14,H17,H18,H20,H24,H25, H26,H27,MMM INSULATION,THERMAL,.....	1

END OF FIGURE

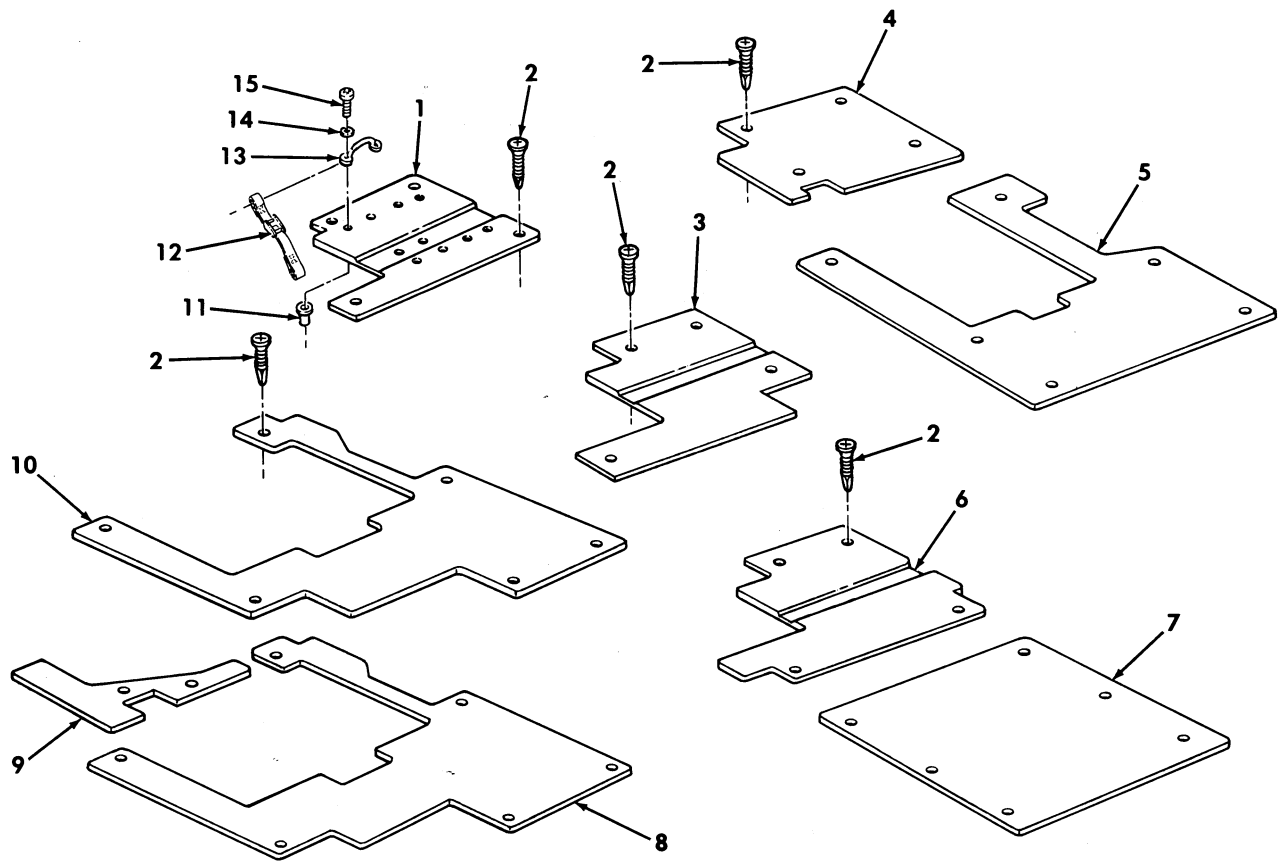
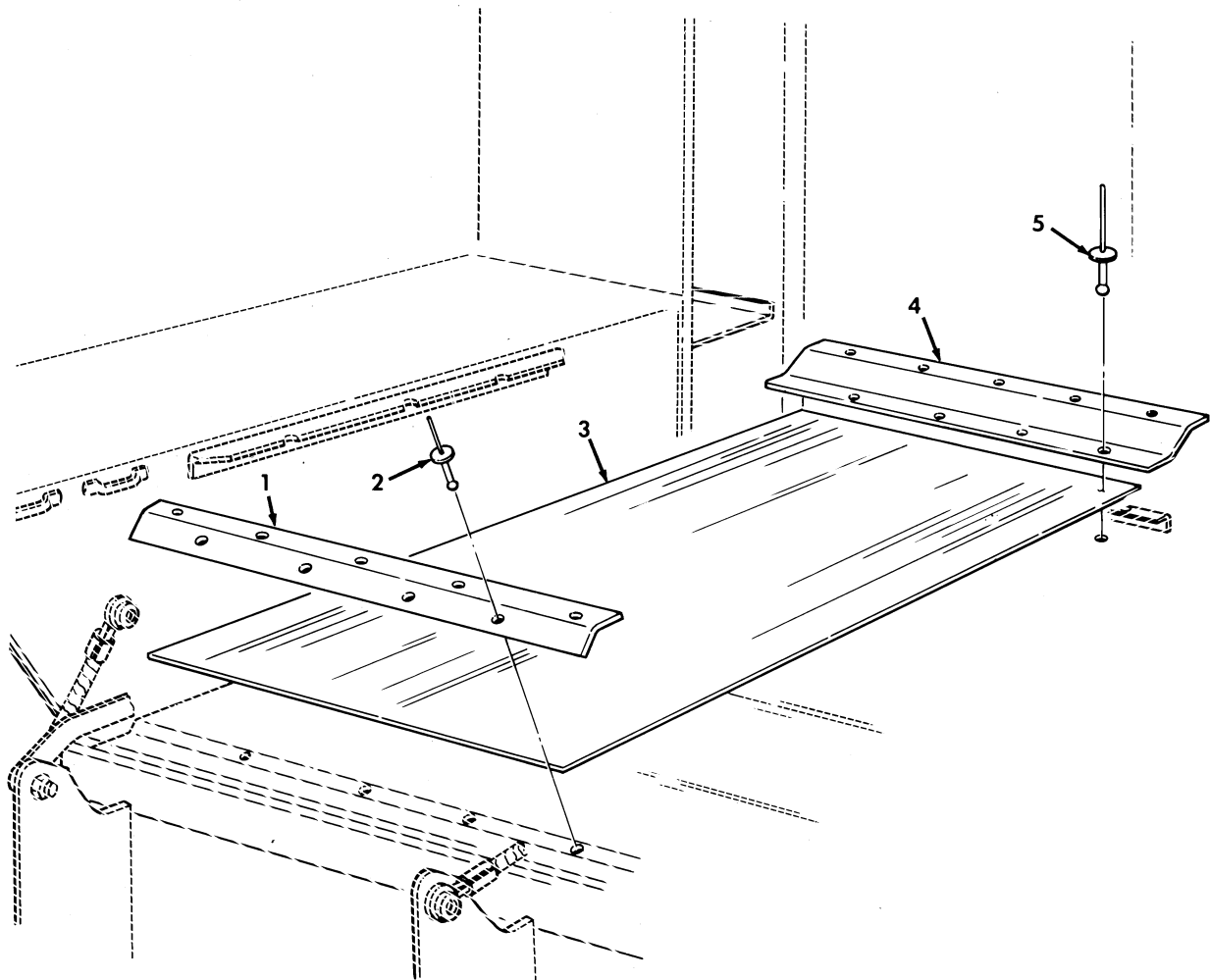

Figure 228. Insulation Floorboard, Front and Rear.

SECTION II			TM9-2320-280-24P			
(1)	(2)	(3)	(4)	(5)	(6)	(7)
ITEM NO	SMR CODE	NSN	CAGEC	PART NUMBER	DESCRIPTION AND USABLE ON CODES(UOC)	QTY
GROUP 1805 FLOORS AND SUBFLOORS						
FIG. 228 INSULATION FLOORBOARD, FRONT AND REAR						
1	PAOZZ	2510013732783	19207	12340872	INSULATION PANEL,VE TUNNEL,FRONT... UOC:AVY,BVY,HVY,H21,H28,NNN	1
2	PAOZZ	5305012707225	19207	12341822	SCREW,TAPPING THREA #10-16 X 1.00.. UOC:A25,B17,B18,B25,C17,H17,H18,H25, H26	8
2	PAOZZ	5305012707225	19207	12341822	SCREW,TAPPING THREA #10-16 X 1.00.. UOC:A13,A14,B24,H13,H14,H24,H27	10
2	PAOZZ	5305012707225	19207	12341822	SCREW,TAPPING THREA #10-16 X 1.00.. UOC:AVY,A15,A20,BVY,B15,B16,B20,HVY, H15,H16,H20,H21,H28,NNN	4
3	PAOZZ	2510013730131	19207	12340871	INSULATION PANEL,VE TUNNEL,FRONT... UOC:A20,B20,H20	1
4	PAOZZ	2510013729734	19207	12340874	INSULATION PANEL,VE TUNNEL,FRONT... UOC:A24,A27,B24,H24,H27	1
5	PAOZZ	2510013732784	19207	12340877	INSULATION PANEL,VE TUNNEL,REAR.... UOC:A24,A27,B24,H24,H27	1
6	PAOZZ	2510012811032	34623	SF5597161	INSULATION,PANEL FRONT..... UOC:A13,A14,A15,B15,B16,H13,H14,H15, H16	1
7	PAOZZ	2510013737877	34623	12340873	INSULATION PANEL,VE TUNNEL,REAR.... UOC:A13,A14,H13,H14	1
8	PAOZZ	2510013738445	19207	12340876	INSULATION PANEL,VE TUNNEL,REAR.... UOC:A25,A26,B25,H25,H26	1
9	PAOZZ	2510013740000	19207	12340875	INSULATION PANEL,VE TUNNEL,FRONT... UOC:A25,A26,B17,B18,B25,C17,H17,H18, H25,H26	1
10	PAOZZ	2510012717085	19207	12341689	PANEL,BODY,VEHICULA TUNNEL,REAR.... UOC:B17,B18,C17,H17,H18	1
11	PAOZZ	5310001265168	96906	MS27130-A37	NUT,PLAIN,BLIND,RIV 1/4..... UOC:BVY,B15,NNN	10
12	PAOZZ	5340014765616	19207	12340448-1	STRAP,RETAINING..... UOC:BVY,B15,NNN	2
13	PAOZZ	5340011978674	19207	12338839-6	LOOP,STRAP,FASTENER..... UOC:BVY,B15,NNN	5
14	PAOZZ	5310005432705	24617	120380	WASHER,LOCK 1/4..... UOC:BVY,B15,NNN	10
15	PAOZZ	5305002678954	80204	B1821BH025F125N	SCREW,CAP,HEXAGON H 1/4-20 X 1.25.. UOC:BVY,B15,NNN	10

END OF FIGURE



*Figure 229. Floor Mat Cover and Related Hardware, M996, M996A1, M997, M997A1, and M997A2 Ambulance.*

SECTION II			TM9-2320-280-24P			
(1)	(2)	(3)	(4)	(5)	(6)	(7)
ITEM	SMR			PART		
NO	CODE	NSN	CAGEC	NUMBER	DESCRIPTION AND USABLE ON CODES(UC)	QTY
GROUP 1805 FLOORS AND SUBFLOORS						
FIG. 229 FLOOR MAT COVER AND RELATED HARDWARE, M996, M996A1, M997, M997A1, AND M997A2 AMBULANCE						
1	PAOZZ	2540012709344	19207	12340979	MAT, FLOOR.....	1
					UOC:A15, B15, B16, H15, H16	
2	PAOZZ	5320010232529	81349	M24243/1-A404	RIVET, BLIND 1/8.....	9
					UOC:A15, B15, B16, H15, H16	
3	PAOZZ	2540012665702	19207	12341155	MAT, FLOOR.....	1
					UOC:A15, B15, B16, H15, H16	
4	PAOZZ	5975012752695	19207	12341492	PROTECTOR, ELECTRICA.....	1
					UOC:A15, B15, B16, H15, H16	
5	PAOZZ	5320011361782	81349	M7885/2-6-04	RIVET, BLIND 3/16.....	9
					UOC:A15, B15, B16, H15, H16	

END OF FIGURE

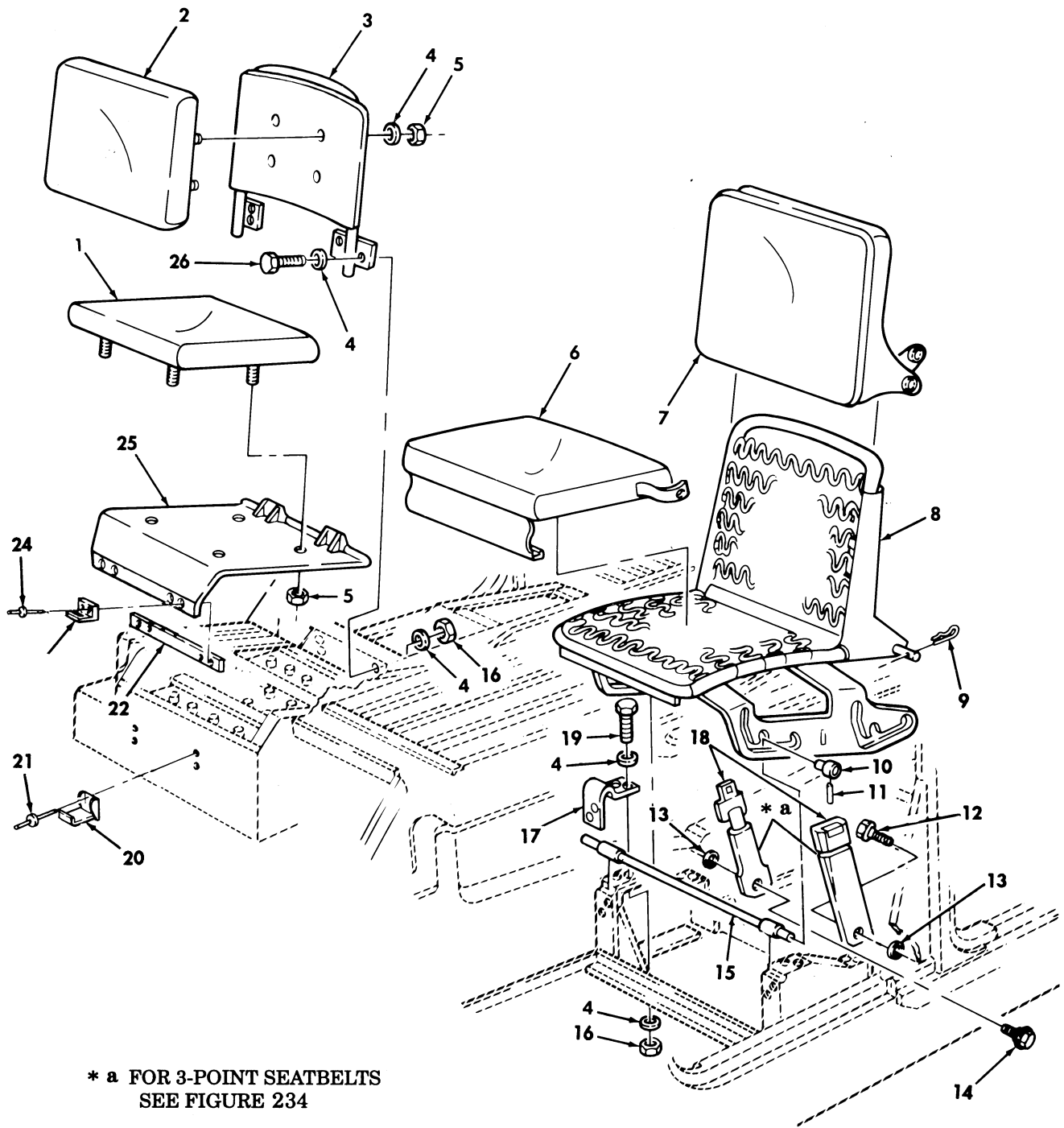

Figure 230. Seats and Belts, Front.

SECTION II			TM9-2320-280-24P			
(1)	(2)	(3)	(4)	(5)	(6)	(7)
ITEM	SMR			PART		
NO	CODE	NSN	CAGEC	NUMBER	DESCRIPTION AND USABLE ON CODES(UOC)	QTY
GROUP 1806 UPHOLSTERY SEATS AND CARPET						
FIG. 230 SEATS AND BELTS,FRONT						
1	PAOZZ	2540013147834	34623	12342068	CUSHION,SEAT,VEHICU.....	1
					UOC:HVY,H11,H13,H14,H15,H16,H17,H18,H20,H21,H24,H25,H26,H27,H28,MMM	
2	PAOZZ	2540013149378	16236	2540V0751	CUSHION,SEAT BACK,V.....	1
					UOC:HVY,H11,H13,H14,H15,H16,H17,H18,H20,H21,H24,H25,H26,H27,H28,MMM	
3	PFOZZ	2540011846602	19207	12338528	FRAME,SEAT,VEHICULA.....	1
					UOC:HVY,H11,H13,H14,H15,H16,H17,H18,H20,H21,H24,H25,H26,H27,H28,MMM	
4	PAOZZ	5310000814219	96906	MS27183-12	WASHER,FLAT R.H.,5/16.....	28
					UOC:HVY,H11,H13,H14,H15,H16,H17,H18,H20,H21,H24,H25,H26,H27,H28,MMM	
5	PAOZZ	5310008807744	96906	MS51967-5	NUT,PLAIN,HEXAGON R.H.,5/16-18.....	8
					UOC:HVY,H11,H13,H14,H15,H16,H17,H18,H20,H21,H24,H25,H26,H27,H28,MMM	
6	PAOZZ	2540013130678	19207	12342047	CUSHION,SEAT,VEHICU.....	1
					UOC:HVY,H11,H13,H14,H15,H16,H17,H18,H20,H21,H24,H25,H26,H27,H28,MMM	
7	PAOZZ	2540013147835	34623	12342061	CUSHION,SEAT BACK,V.....	1
					UOC:HVY,H11,H13,H14,H15,H16,H17,H18,H20,H21,H24,H25,H26,H27,H28,MMM	
8	PAOZZ	2540013189229	19207	12338503-1	FRAME,SEAT,VEHICULA.....	1
					UOC:HVY,H11,H13,H14,H15,H16,H17,H18,H20,H21,H24,H25,H26,H27,H28,MMM	
9	PAOZZ	5315012806185	70655	10392	PIN,LOCK.....	4
					UOC:HVY,H11,H13,H14,H15,H16,H17,H18,H20,H21,H24,H25,H26,H27,H28,MMM	
10	PAOZZ	3040012519383	19207	12338539	COLLAR,SHAFT.....	4
					UOC:HVY,H11,H13,H14,H15,H16,H17,H18,H20,H21,H24,H25,H26,H27,H28,MMM	
11	PAOZZ	5315008143529	80205	MS16562-20	PIN,SPRING.....	4
					UOC:HVY,H11,H13,H14,H15,H16,H17,H18,H20,H21,H24,H25,H26,H27,H28,MMM	
12	PFOZZ	5305012542522	19207	12340259	SCREW,CAP,HEXAGON H L.H.,R.H.,7/16-20 X 57/64,USBL EFF 1 THRU 99,999...	2
					UOC:H11,H13,H14,H15,H16,H17,H18,H20,H21,H24,H25,H26,H27,H28,MMM	
13	PAOZZ	5310012538437	19207	12340058	WASHER,FLAT USBL EFF 1 THRU 99,999.	4
					UOC:H11,H13,H14,H15,H16,H17,H18,H20,H21,H24,H25,H26,H27,H28,MMM	
14	PFOZZ	5305012643555	19207	12340259-2	SCREW,CAP,HEXAGON H 7/16-20 X 1.19,USBL EFF 1 THRU 99,999.....	2
					UOC:H11,H13,H14,H15,H16,H17,H18,H20,H21,H24,H25,H26,H27,H28,MMM	
14	PAOZZ	5306014505947	19207	12340259-10	BOLT,SHOULDER FOR REPAIR ONLY,USE WITH ITEM 13 AND 27,7/16-20 X 1.31 USBL EFF 1 THRU 99,999.....	2
					UOC:HVY,H11,H13,H14,H15,H16,H17,H18,	



SECTION II			TM9-2320-280-24P			
(1)	(2)	(3)	(4)	(5)	(6)	(7)
ITEM	SMR			PART		
NO	CODE	NSN	CAGEC	NUMBER	DESCRIPTION AND USABLE ON CODES(UC)	QTY
15	PAOZZ	3040011921632	19207	12338536	H20,H21,H24,H25,H26,H27,H28,MMM SHAFT,STRAIGHT.....	2
					UOC:HVY,H11,H13,H14,H15,H16,H17,H18, H20,H21,H24,H25,H26,H27,H28,MMM	
16	PAOZZ	5310008140673	96906	MS51943-33	NUT,SELF-LOCKING,HE 5/16-18.....	20
					UOC:HVY,H11,H13,H14,H15,H16,H17,H18, H20,H21,H24,H25,H26,H27,H28,MMM	
17	PFOZZ	5340011858723	19207	12338540	BRACKET,ANGLE.....	4
					UOC:HVY,H11,H13,H14,H15,H16,H17,H18, H20,H21,H24,H25,H26,H27,H28,MMM	
18	PAOZZ	2540012030183	70308	E06879-00	BELT,VEHICULAR SAFE USBL EFF 1 THRU 99,999.....	2
					UOC:H11,H13,H14,H15,H16,H17,H18,H20, H21,H24,H25,H26,H27,H28,MMM	
19	PAOZZ	5306002264826	80204	B1821BH031C088N	BOLT,MACHINE 5/16-18 X 7/8.....	16
					UOC:HVY,H11,H13,H14,H15,H16,H17,H18, H20,H21,H24,H25,H26,H27,H28,MMM	
20	PAOZZ	5340011971294	29372	20L01-1-1AF	CATCH,CLAMPING.....	2
					UOC:HVY,H11,H13,H14,H15,H16,H17,H18, H20,H21,H24,H25,H26,H27,H28,MMM	
21	PAOZZ	5320012544251	34623	5593050	RIVET,BLIND 3/16 DIA.....	4
					UOC:HVY,H11,H13,H14,H15,H16,H17,H18, H20,H21,H24,H25,H26,H27,H28,MMM	
22	PAOZZ	2590012615485	34623	5591553	MOLDING,METAL.....	1
					UOC:HVY,H11,H13,H14,H15,H16,H17,H18, H20,H21,H24,H25,H26,H27,H28,MMM	
23	PAOZZ	5340010874612	71286	20L02-1-1AA	STRIKE,CATCH.....	2
					UOC:HVY,H11,H13,H14,H15,H16,H17,H18, H20,H21,H24,H25,H26,H27,H28,MMM	
24	PAOZZ	5320012200596	11815	CR-213-4-4	RIVET,BLIND 1/8 DIA.....	4
					UOC:HVY,H11,H13,H14,H15,H16,H17,H18, H20,H21,H24,H25,H26,H27,H28,MMM	
25	PAOZZ	6160012639784	19207	12339038	COVER,BATTERY BOX.....	1
					UOC:HVY,H11,H13,H14,H15,H16,H17,H18, H20,H21,H24,H25,H26,H27,H28,MMM	
26	PAOZZ	5306002264825	80204	B1821BH031C075N	BOLT,MACHINE 5/16-18 X 3/4.....	4
					UOC:HVY,H11,H13,H14,H15,H16,H17,H18, H20,H21,H24,H25,H26,H27,H28,MMM	

END OF FIGURE

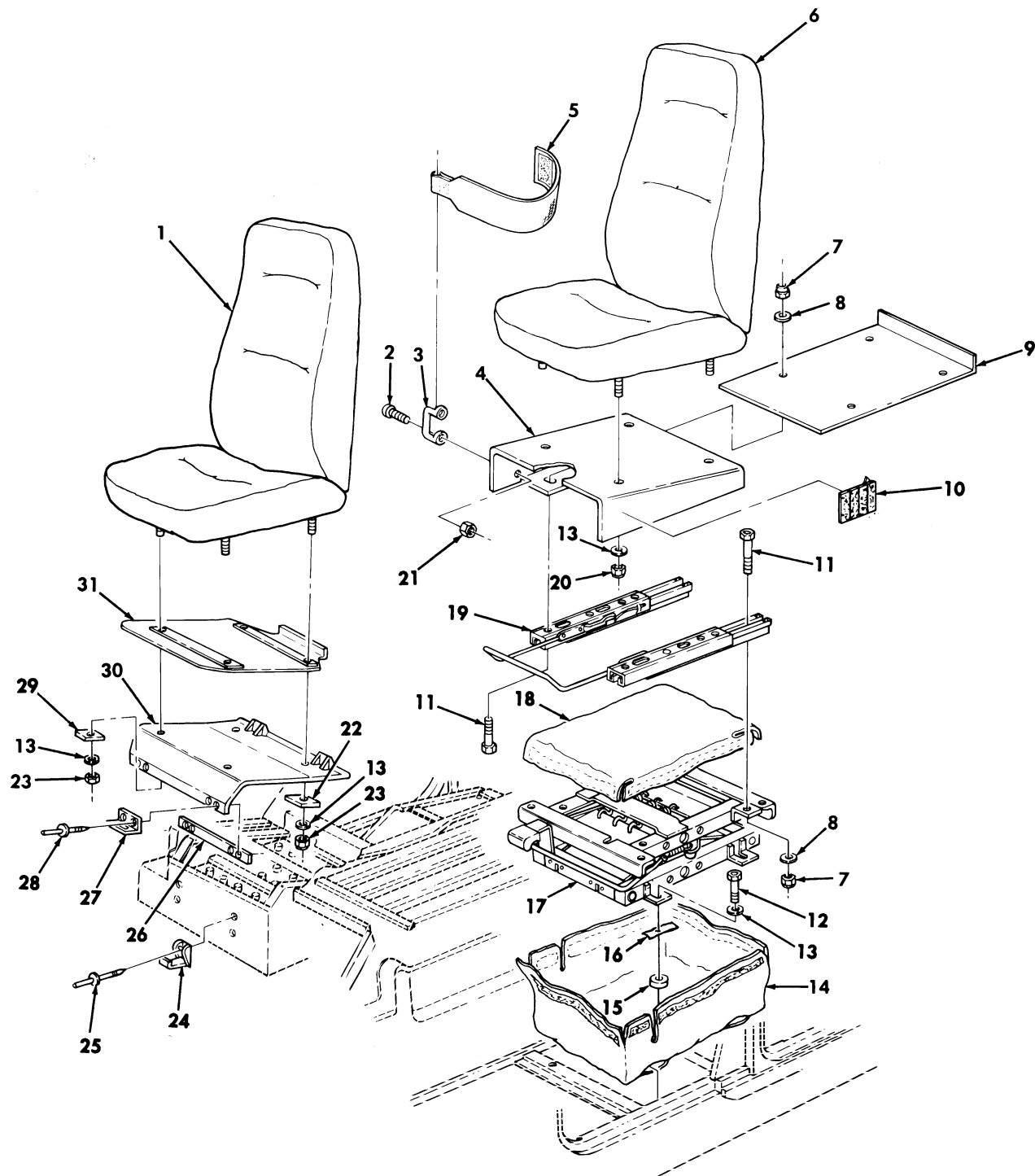

Figure 231. Commander's Seat, Driver's Seat, and Related Parts.

SECTION II			TM9-2320-280-24P			
(1)	(2)	(3)	(4)	(5)	(6)	(7)
ITEM NO	SMR CODE	NSN	CAGEC	PART NUMBER	DESCRIPTION AND USABLE ON CODES(UOC)	QTY
GROUP 1806 UPHOLSTERY SEATS AND CARPET						
FIG. 231 COMMANDER'S SEAT, DRIVER'S SEAT, AND RELATED PARTS						
1	PAOZZ	2540013818392	62226	8.6046	SEAT, VEHICULAR COMMANDER'S..... UOC:AVY,A11,A13,A14,A15,A20,A24,A25, A26,A27,BVY,B15,B16,B17,B18,B20,B24, B25,C17,NNN	1
2	PAOZZ	5305013812305	24617	157125	SCREW, MACHINE #10-32 X .62..... UOC:AVY,A11,A13,A14,A15,A20,A24,A25, A26,A27,BVY,B15,B16,B17,B18,B20,B24, B25,C17,NNN	2
3	PAOZZ	5340013145957	19207	12338839-1	LOOP, STRAP FASTENER..... UOC:AVY,A11,A13,A14,A15,A20,A24,A25, A26,A27,BVY,B15,B16,B17,B18,B20,B24, B25,C17,NNN	1
4	PFOZZ	2540013835660	19207	12343053	SEAT, VEHICULAR..... UOC:AVY,A11,A13,A14,A15,A20,A24,A25, A26,A27,BVY,B15,B16,B17,B18,B20,B24, B25,C17,NNN	1
5	PAOZZ	5340013870090	19207	12446724	STRAP, WEBBING..... UOC:AVY,A11,A13,A14,A15,A20,A24,A25, A26,A27,BVY,B15,B16,B17,B18,B20,B24, B25,C17,NNN	1
6	PAOZZ	2540014364175	62226	8.6272-01	SEAT, VEHICULAR DRIVER'S..... UOC:AVY,A11,A13,A14,A15,A20,A24,A25, A26,A27,BVY,B15,B16,B17,B18,B20,B24, B25,C17,NNN	1
7	PAOZZ	5310011193668	24617	9422295	NUT, SELF-LOCKING, CO .312-20..... UOC:AVY,A11,A13,A14,A15,A20,A24,A25, A26,A27,BVY,B15,B16,B17,B18,B20,B24, B25,C17,NNN	8
8	PAOZZ	5310011191024	24617	2436162	WASHER, FLAT 5/16..... UOC:AVY,A11,A13,A14,A15,A20,A24,A25, A26,A27,BVY,B15,B16,B17,B18,B20,B24, B25,C17,NNN	8
9	PAOZZ	2540014473457	34623	12446709	SUPPORT, SEAT, VEHICU..... UOC:AVY,A11,A13,A14,A15,A20,A24,A25, A26,A27,BVY,B15,B16,B17,B18,B20,B24, B25,C17,NNN	1
10	MOOZZ		19207	12331924-6	FASTENER, TAPE MAKE FROM FASTENER, TAPE, P/N 20197272, 2 INCHES LONG..... UOC:AVY,A11,A13,A14,A15,A20,A24,A25, A26,A27,BVY,B15,B16,B17,B18,B20,B24, B25,C17,NNN	1
11	PAOZZ	5305013812296	24617	9421705	SCREW, CAP, SOCKET HE 5/16-18 X 3/4.. UOC:AVY,A11,A13,A14,A15,A20,A24,A25, A26,A27,BVY,B15,B16,B17,B18,B20,B24, B25,C17,NNN	8
12	PAOZZ	5306002264826	80204	B1821BH031C088N	BOLT, MACHINE..... UOC:AVY,A11,A13,A14,A15,A20,A24,A25,	4

SECTION II			TM9-2320-280-24P			
(1)	(2)	(3)	(4)	(5)	(6)	(7)
ITEM NO	SMR CODE	NSN	CAGEC	PART NUMBER	DESCRIPTION AND USABLE ON CODES(UC)	QTY
13	PAOZZ	5310004079566	96906	MS35338-45	A26,A27,BVY,B15,B16,B17,B18,B20,B24, B25,C17,NNN WASHER, LOCK.....	12
					UOC:AVY,A11,A13,A14,A15,A20,A24,A25, A26,A27,BVY,B15,B16,B17,B18,B20,B24, B25,C17,NNN	
14	PAOZZ		19207	12460212	COVER, SEAT PEDESAL.....	1
					UOC:AVY,A11,A13,A14,A15,A20,A24,A25, A26,A27,BVY,B15,B16,B17,B18,B20,B24, B25,C17,NNN	
15	PAOZZ	5310011191024	24617	2436162	WASHER, FLAT 5/16.....	4
					UOC:AVY,A11,A13,A14,A15,A20,A24,A25, A26,A27,BVY,B15,B16,B17,B18,B20,B24, B25,C17,NNN	
16	MOOZZ		19207	12339376-1	TAPE, PRESSURE SENSI MAKE FROM TAPE, V P/N 12339376-1, LENGTH AS NEEDED.....	
					UOC:AVY,A11,A13,A14,A15,A20,A24,A25, A26,A27,BVY,B15,B16,B17,B18,B20,B24, B25,C17,NNN	
17	PAOZZ		62226	34068-02	KNOB, HANDLE.....	1
					UOC:AVY,A11,A13,A14,A15,A20,A24,A25, A26,A27,BVY,B15,B16,B17,B18,B20,B24, B25,C17,NNN	
18	PAOZZ	2540013818988	34623	12446714	ADJUSTER, VEHICULAR.....	1
					UOC:AVY,A11,A13,A14,A15,A20,A24,A25, A26,A27,BVY,B15,B16,B17,B18,B20,B24, B25,C17,NNN	
19	PAOZZ	2540014652079	34623	12460213	COVER, SEAT, VEHICULA.....	1
					UOC:AVY,A11,A13,A20,A24,B18,B20,B24, B25,C17,NNN	
20	PAOZZ	2540013819331	62226	0.1581	ADJUSTER, VEHICULAR.....	1
					UOC:AVY,A11,A13,A14,A15,A20,A24,A25, A26,A27,BVY,B15,B16,B17,B18,B20,B24, B25,C17,NNN	
21	PAOZZ	5310012097702	7X677	9429048	NUT, PLAIN, HEXAGON 5/16-18.....	4
					UOC:AVY,A11,A13,A14,A15,A20,A24,A25, A26,A27,BVY,B15,B16,B17,B18,B20,B24, B25,C17,NNN	
22	PAOZZ	5310001249265	72582	271169	NUT, PLAIN, ASSEMBLED #10-32.....	2
					UOC:AVY,A11,A13,A14,A15,A20,A24,A25, A26,A27,BVY,B15,B16,B17,B18,B20,B24, B25,C17,NNN	
23	PAOZZ	5365013807340	19207	12446735	SPACER, TAPERED.....	2
					UOC:AVY,A11,A13,A14,A15,A20,A24,A25, A26,A27,BVY,B15,B16,B17,B18,B20,B24, B25,C17,NNN	
24	PAOZZ	5310013815328	24617	9413583	NUT, PLAIN, HEXAGON 5/16-18.....	4
					UOC:AVY,A11,A13,A14,A15,A20,A24,A25, A26,A27,BVY,B15,B16,B17,B18,B20,B24, B25,C17,NNN	
25	PAOZZ	5340011971294	29372	20L01-1-1AF	CATCH, CLAMPING.....	2
					UOC:AVY,A11,A13,A14,A15,A20,A24,A25, A26,A27,BVY,B15,B16,B17,B18,B20,B24,	

SECTION II			TM9-2320-280-24P			
(1)	(2)	(3)	(4)	(5)	(6)	(7)
ITEM	SMR			PART		
NO	CODE	NSN	CAGEC	NUMBER	DESCRIPTION AND USABLE ON CODES(UOC)	QTY
26	PAOZZ	5320012544251	34623	5593050	B25,C17,NNN RIVET,BLIND 3/16 DIA.....	4
					UOC:AVY,A11,A13,A14,A15,A20,A24,A25, A26,A27,BVY,B15,B16,B17,B18,B20,B24, B25,C17,NNN	
27	PAOZZ	2590012615485	34623	5591553	MOLDING,METAL.....	1
					UOC:AVY,A11,A13,A14,A15,A20,A24,A25, A26,A27,BVY,B15,B16,B17,B18,B20,B24, B25,C17,NNN	
28	PAOZZ	5340010874612	71286	20L02-1-1AA	STRIKE,CATCH.....	2
					UOC:AVY,A11,A13,A14,A15,A20,A24,A25, A26,A27,BVY,B15,B16,B17,B18,B20,B24, B25,C17,NNN	
29	PAOZZ	5320012200596	11815	CR-213-4-4	RIVET,BLIND 1/8 DIA.....	4
					UOC:AVY,A11,A13,A14,A15,A20,A24,A25, A26,A27,BVY,B15,B16,B17,B18,B20,B24, B25,C17,NNN	
30	PAOZZ	5365013821178	19207	12446736	SPACER,TAPERED.....	2
					UOC:AVY,A11,A13,A14,A15,A20,A24,A25, A26,A27,BVY,B15,B16,B17,B18,B20,B24, B25,C17,NNN	
31	PAOZZ	6160013843922	19207	12343059	COVER,BATTERY BOX.....	1
					UOC:AVY,A11,A13,A14,A15,A20,A24,A25, A26,A27,BVY,B15,B16,B17,B18,B20,B24, B25,C17,NNN	
32	PAOZZ	6160013840325	19207	12446737	COVER,BATTERY BOX.....	1
					UOC:AVY,A11,A13,A14,A15,A20,A24,A25, A26,A27,BVY,B15,B16,B17,B18,B20,B24, B25,C17,NNN	

END OF FIGURE

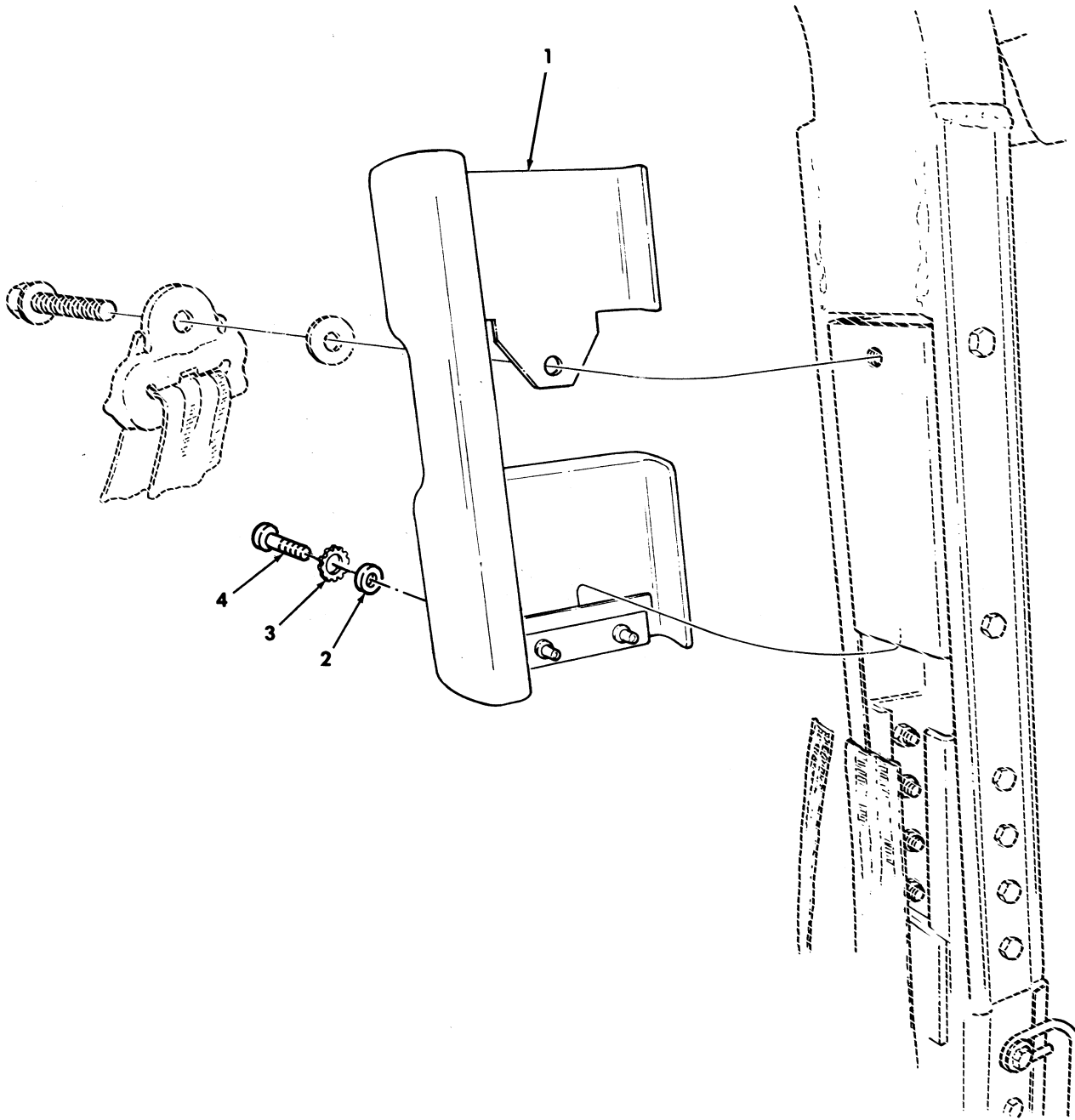

Figure 232. Protective Padding on "B" Pillar For Non-Armored Vehicles.

SECTION II			TM9-2320-280-24P			
(1)	(2)	(3)	(4)	(5)	(6)	(7)
ITEM	SMR			PART		
NO	CODE	NSN	CAGEC	NUMBER	DESCRIPTION AND USABLE ON CODES(UC)	QTY
					GROUP 1806 UPHOLSTERY SEATS AND CARPET	
					FIG. 232 PROTECTIVE PADDING ON "B" PILLAR FOR NON-ARMORED VEHICLES	
1	PAOZZ	2590013961422	19207	12342954	PAD,CUSHIONING B PILLAR,R.H..... UOC:AVY,A13,A14,A20,BVY,B20,HVY,H13,H14,H20,H21,H28,NNN	1
1	PAOZZ	2590013961424	19207	12342955	PAD,CUSHIONING B PILLAR,L.H..... UOC:AVY,A13,A14,A20,BVY,B20,HVY,H13,H14,H20,H21,H28,NNN	1
2	PAOZZ	5310000120391	24617	120391	WASHER,FLAT #10..... UOC:AVY,A13,A14,A20,BVY,B20,HVY,H13,H14,H20,H21,H28,NNN	4
3	PAOZZ	5310014622175	24617	138482	WASHER,LOCK #10-32..... UOC:AVY,A13,A14,A20,BVY,B20,HVY,H13,H14,H20,H21,H28,NNN	4
4	PAOZZ	5305011858647	24617	160057	SCREW,MACHINE #10-32 X 3/4..... UOC:AVY,A13,A14,A20,BVY,B20,HVY,H13,H14,H20,H21,H28,NNN	4

END OF FIGURE

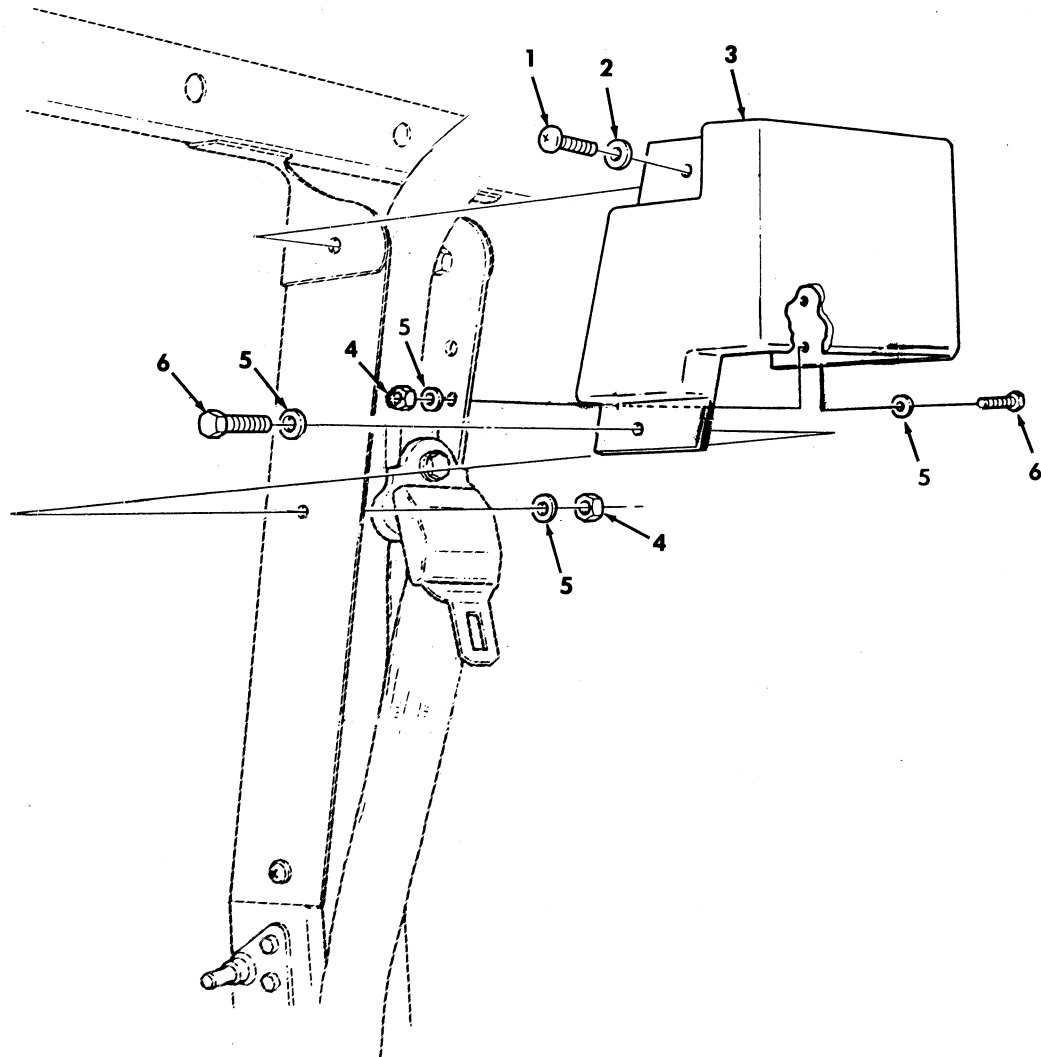

Figure 233. Protective Padding On "B" Pillar Cover For Armored Vehicles..



SECTION II			TM9-2320-280-24P			
(1)	(2)	(3)	(4)	(5)	(6)	(7)
ITEM NO	SMR CODE	NSN	CAGEC	PART NUMBER	DESCRIPTION AND USABLE ON CODES(UC)	QTY
					GROUP 1806 UPHOLSTERY SEATS AND CARPET	
					FIG. 233 PROTECTIVE PADDING ON "B" PILLAR COVER FOR ARMORED VEHICLES	
1	PAOZZ	5305009845678	96906	MS35206-298	SCREW,MACHINE 5/16 X 1.00.....	2
					UOC:A11,A24,A25,A26,A27,BVY,B17,B18,B24,B25,C17,H11,H17,H18,H24,H25,H26,H27,MMM,NNN	
2	PAOZZ	5310008093078	96906	MS27183-11	WASHER,FLAT 5/16.....	2
					UOC:A11,A24,A25,A26,A27,BVY,B17,B18,B24,B25,C17,H11,H17,H18,H24,H25,H26,H27,MMM,NNN	
3	PAOZZ	2590013949673	9C234	12446741	PAD,CUSHIONING RIGHT.....	1
					UOC:A11,A24,A25,A26,A27,BVY,B17,B18,B24,B25,C17,H11,H17,H18,H24,H25,H26,H27,MMM,NNN	
3	PAOZZ	2590013965007	19207	12446739	PAD,CUSHIONING LEFT.....	1
					UOC:A11,A24,A25,A26,A27,BVY,B17,B18,B24,B25,C17,H11,H17,H18,H24,H25,H26,H27,MMM,NNN	
4	PAOZZ	5310010666759	72962	21NE-040	NUT,SELF-LOCKING,HE 1/4-20 (TOW CARRIER).....	6
					UOC:A11,A24,A27,B24,H11,H24,H27,MMM	
4	PAOZZ	5310010666759	72962	21NE-040	NUT,SELF-LOCKING,HE 1/4-20 (ARMY)..	3
					UOC:B17,B18,C17,H17,H18	
5	PAOZZ	5310011023270	24617	2436161	WASHER,FLAT 1/4 (TOW CARRIER).....	12
					UOC:A11,A24,A27,B24,H11,H24,H27,MMM	
5	PAOZZ	5310011023270	24617	2436161	WASHER,FLAT 1/4 (ARMY).....	6
					UOC:B17,B18,C17,H17,H18	
6	PAOZZ	5305000680508	80204	B1821BH025C075N	SCREW,CAP,HEXAGON H 1/4-20 X 0.75 (TOW CARRIER).....	6
					UOC:A11,A24,A27,B24,H11,H24,H27,MMM	
6	PAOZZ	5305000680508	80204	B1821BH025C075N	SCREW,CAP,HEXAGON H 1/4-20 X 0.75 (ARMY).....	3
					UOC:B17,B18,C17,H17,H18	
7	PAOZZ	2590014608320	19207	12340103-3	BEZEL,AUTOMOTIVE TR LEFT 11.13 INCHES LONG.....	2
					UOC:A11,A24,A25,A26,A27,BVY,B17,B18,B24,B25,C17,H11,H17,H18,H24,H25,H26,H27,MMM,NNN	

END OF FIGURE

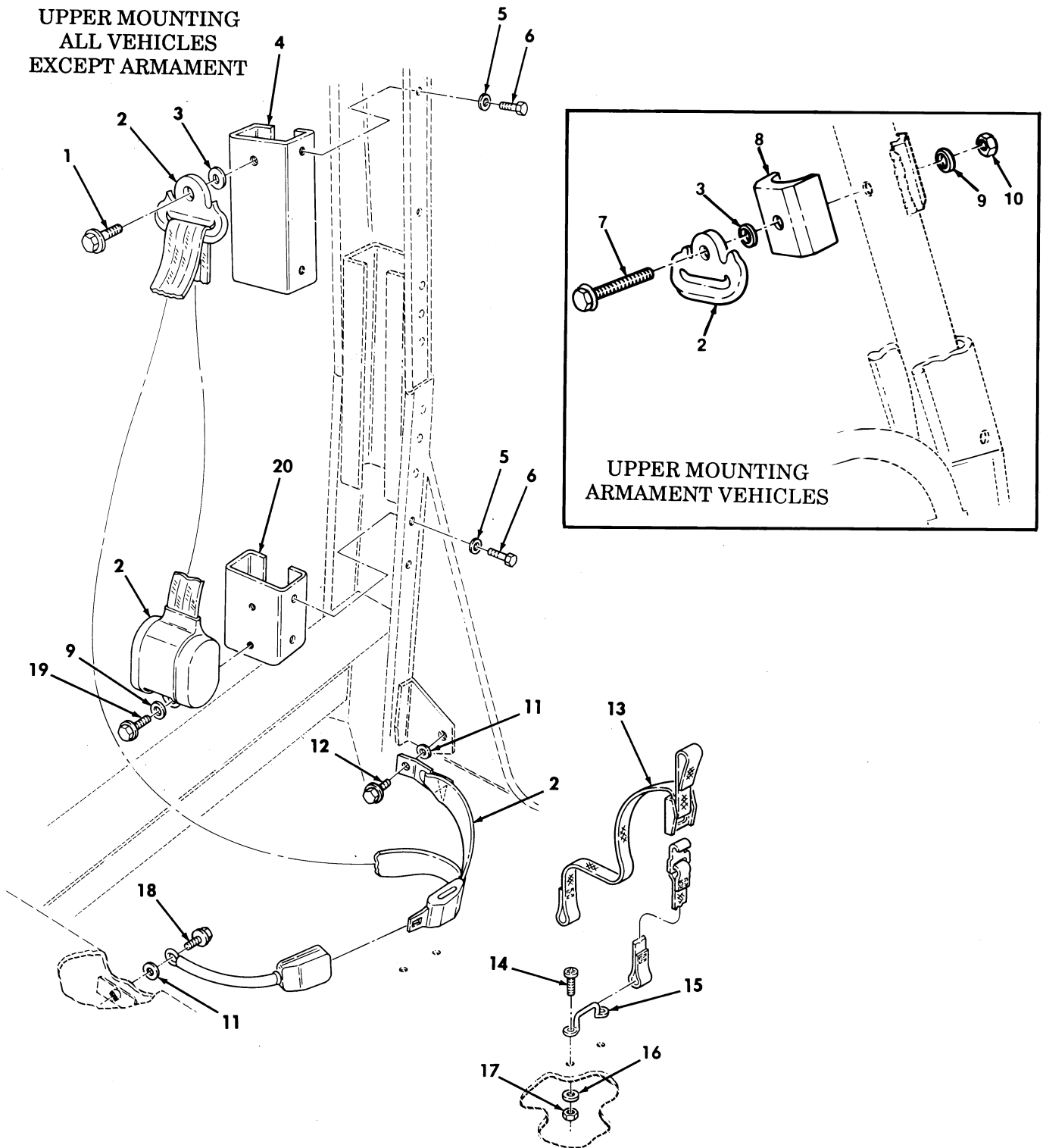

Figure 234. Front Seatbelts, Brackets, and Mounting Hardware.

SECTION II			TM9-2320-280-24P			
(1)	(2)	(3)	(4)	(5)	(6)	(7)
ITEM	SMR			PART		
NO	CODE	NSN	CAGEC	NUMBER	DESCRIPTION AND USABLE ON CODES(UOC)	QTY
					GROUP 1806 UPHOLSTERY SEATS AND CARPET	
					FIG. 234 FRONT SEATBELTS, BRACKETS, AND MOUNTING HARDWARE	
1	PAOZZ	5306013162433	19207	12340259-7	BOLT, SHOULDER SEAT BELT, 7/16-20 X 1.00, USBL EFF 100,000 AND ABOVE.....	2
					UOC:AVY,A13,A14,A20,BVY,B20,HVY,H13,H14,H20,H21,H28,NNN	
2	PAOZZ	2540013153358	7X868	E19250-00	BELT, VEHICULAR SAFE DRIVER, USBL EFF 100,000 AND ABOVE.....	1
2	PAOZZ	2540013153143	29944	F07011	BELT, VEHICULAR SAFE COMMANDER, USBL EFF 100,000 AND ABOVE.....	1
3	PAOZZ	5310012866077	19207	12341856	WASHER, FLAT 7/16.....	2
4	PFOZZ	2590013949672	9C234	12342683	BRACKET, VEHICULAR C USBL EFF 100,000 AND ABOVE.....	2
					UOC:AVY,A13,A14,A20,BVY,B20,HVY,H13,H14,H20,H21,H28,NNN	
5	PAOZZ	5310011191024	24617	2436162	WASHER, FLAT USBL EFF 100,000 AND ABOVE.....	16
					UOC:AVY,A13,A14,A20,BVY,B20,HVY,H13,H14,H20,H21,H28,NNN	
5	PAOZZ	5310011191024	24617	2436162	WASHER, FLAT USBL EFF 100,000 AND ABOVE.....	8
					UOC:A11,A24,A25,A26,A27,B17,B18,B24,B25,C17,H11,H17,H18,H24,H25,H26,H27,MMM	
6	PAOZZ	5306002264825	80204	B1821BH031C075N	BOLT, MACHINE 5/16-18 X .75, USBL EFF 100,000 AND ABOVE.....	16
					UOC:AVY,A14,A20,BVY,B20,HVY,H13,H14,H20,H21,H28,NNN	
6	PAOZZ	5306002264825	80204	B1821BH031C075N	BOLT, MACHINE 5/16-18 X .75, USBL EFF 100,000 AND ABOVE.....	8
					UOC:A11,A24,A25,A26,A27,B17,B18,B24,B25,C17,H11,H17,H18,H24,H25,H26,H27,MMM	
7	PAOZZ	5306013157088	19207	12340259-4	BOLT, SHOULDER ROLLBAR BRACKET, 7/16-20 X .47, USBL EFF 100,000 AND ABOVE.....	2
					UOC:A11,A24,A25,A26,A27,B17,B18,B24,B25,C17,H11,H17,H18,H24,H25,H26,H27,MMM	
8	PAOZZ	5340013335851	19207	12342381	STRAP, RETAINING USBL EFF 100,000 AND ABOVE.....	2
					UOC:A11,A24,A25,A26,A27,B17,B18,B24,B25,C17,H11,H17,H18,H24,H25,H26,H27,MMM	
9	PAOZZ	5310008094085	96906	MS27183-16	WASHER, FLAT 7/16, USBL EFF 100,000 AND ABOVE.....	2
					UOC:AVY,A14,A20,BVY,B20,HVY,H13,H14,H20,H21,H28,NNN	
9	PAOZZ	5310008094085	96906	MS27183-16	WASHER, FLAT 7/16, USBL EFF 100,000	4

SECTION II			TM9-2320-280-24P			
(1)	(2)	(3)	(4)	(5)	(6)	(7)
ITEM NO	SMR CODE	NSN	CAGEC	PART NUMBER	DESCRIPTION AND USABLE ON CODES(UC)	QTY
					AND ABOVE..... UC:A11,A24,A25,A26,A27,B17,B18,B24, B25,C17,H11,H17,H18,H24,H25,H26,H27, MMM	
10	PAOZZ	5310013153403	24617	9442938	NUT,SELF-LOCKING,HE ROLLBAR BRACKET,7/16-20,USBL EFF 100,000	2
					AND ABOVE..... UC:AVY,A11,A13,A14,A20,BVY,B20,HVY, H13,H14,H20,H21,H28,NNN	
11	PAOZZ	5310012538437	19207	12340058	WASHER,FLAT 7/16,USBL EFF 100,000	4
					AND ABOVE.....	
12	PAOZZ	5306013161456	19207	12340259-6	BOLT,SHOULDER USBL EFF 100,000 AND ABOVE.....	2
13	PAOZZ	5340012645833	31272	45410-20	STRAP,WEBBING.....	1
					UC:BVY,B20,NNN	
14	PAOZZ	5305011850114	7X677	157166	SCREW #10-32 X 3/4.....	4
					UC:BVY,B20,NNN	
15	PAOZZ	5340013145957	19207	12338839-1	LOOP,STRAP FASTENER.....	2
					UC:BVY,B20,NNN	
16	PAOZZ	5310012349416	96906	MS51412-2	WASHER,FLAT 3/4.....	4
					UC:BVY,B20,NNN	
17	PAOZZ	5310002514503	24617	9411893	NUT,LOCK.....	4
					UC:BVY,B20,NNN	
18	PAOZZ	5306014378056	19207	12340259-11	BOLT,SHOULDER FOR REPAIR ONLY,USE WITH ITEMS 10 AND 11,7/16-20X 1.47USBL EFF 100,000 AND ABOVE.....	2
19	PAOZZ	5305007098283	96906	MS90727-84	SCREW,CAP,HEXAGON H 7/16-20 X 3/4, USBL EFF 100,000 AND ABOVE.....	2
20	PFOZZ	5340013344241	19207	12342372	BRACKET,DOUBLE ANGL USBL EFF 100, 000 AND ABOVE.....	2

END OF FIGURE

3 — 

4 thru 6
----------------

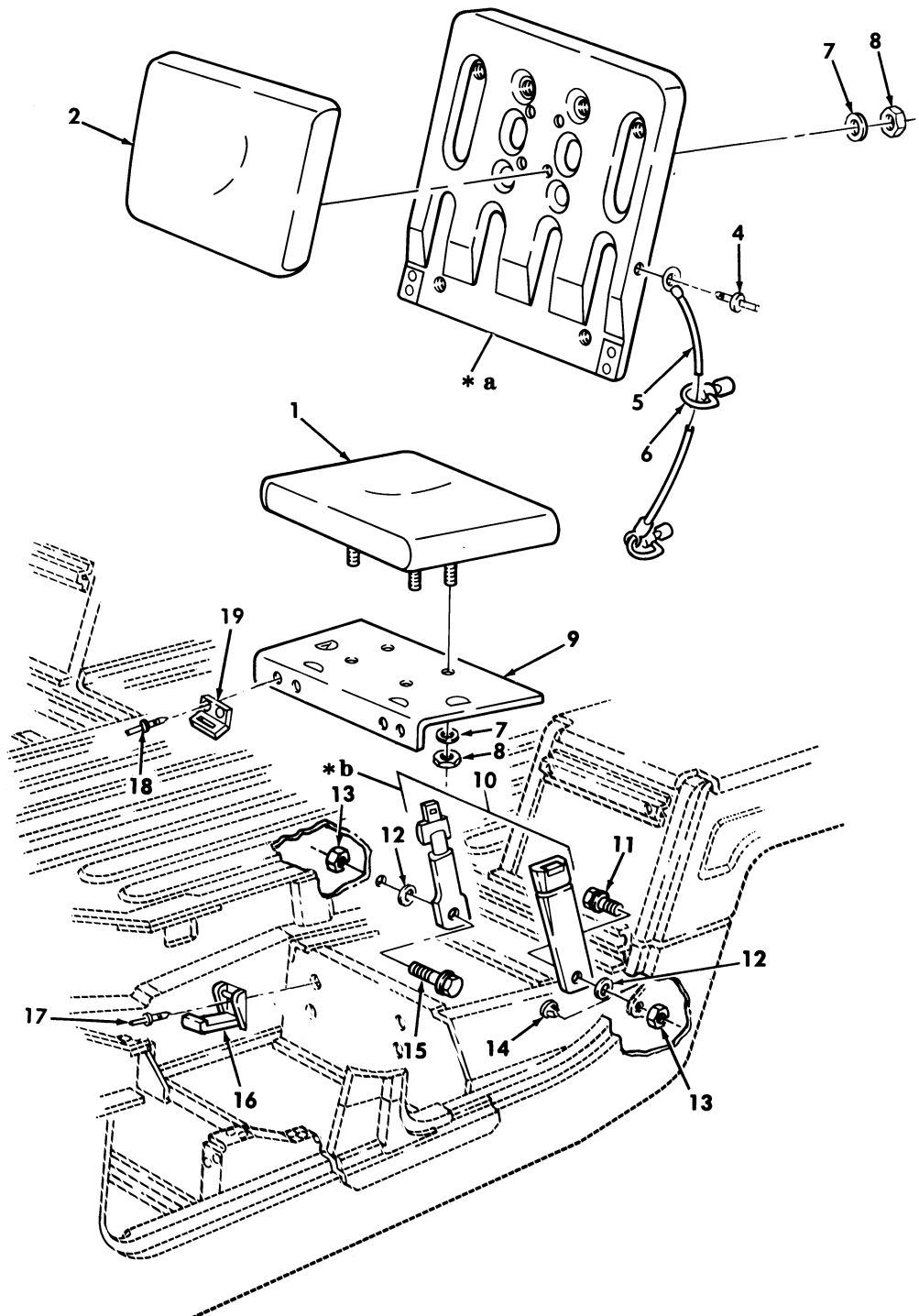

\* a PART OF ITEM 3

\* b FOR 3-POINT SEATBELTS  
SEE FIGURE 239

Figure 235. Seats and Belts, Rear.

SECTION II			TM9-2320-280-24P			
(1)	(2)	(3)	(4)	(5)	(6)	(7)
ITEM NO	SMR CODE	NSN	CAGEC	PART NUMBER	DESCRIPTION AND USABLE ON CODES(UOC)	QTY
GROUP 1806 UPHOLTERY SEATS AND CARPET						
FIG. 235 SEATS AND BELTS,REAR						
1	PAOZZ	2540013147834	34623	12342068	CUSHION,SEAT,VEHICU..... UOC:A11,A13,A14,A24,A25,A26,A27,B24, B25,C17,H11,H13,H14,H17,H18,H24,H25, H26,H27,MMM	1
2	PAOZZ	2540013149378	16236	2540V0751	CUSHION,SEAT BACK,V..... UOC:A11,A13,A14,A24,A25,A26,A27,B24, B25,C17,H11,H13,H14,H17,H18,H24,H25, H26,H27,MMM	2
3	PFOZZ	2540011883229	34623	12340051	FRAME,SEAT,VEHICULA..... UOC:A11,A13,A14,A24,A25,A26,A27,B24, B25,C17,H11,H13,H14,H17,H18,H24,H25, H26,H27,MMM	2
4	PAOZZ	5320011384239	11815	CR3213-4-3	.RIVET,BLIND 1/8 DIA..... UOC:A11,A13,A14,A24,A25,A26,A27,B24, B25,C17,H11,H13,H14,H17,H18,H24,H25, H26,H27,MMM	1
5	PAOZZ	2590012533905	19207	12339420-1	.CABLE AND STUD..... UOC:A11,A13,A14,A24,A25,A26,A27,B24, B25,C17,H11,H13,H14,H17,H18,H24,H25, H26,H27,MMM	1
6	PAOZZ	5325012551126	72794	BJR7-90	.STUD,TURNLOCK FASTE..... UOC:A11,A13,A14,A24,A25,A26,A27,B24, B25,C17,H11,H13,H14,H17,H18,H24,H25, H26,H27,MMM	1
7	PAOZZ	5310000814219	96906	MS27183-12	WASHER,FLAT 5/16..... UOC:A11,A13,A14,A24,A25,A26,A27,B24, B25,C17,H11,H13,H14,H17,H18,H24,H25, H26,H27,MMM	16
8	PAOZZ	5310008807744	96906	MS51967-5	NUT,PLAIN,HEXAGON 5/16-18..... UOC:A11,A13,A14,A24,A25,A26,A27,B24, B25,C17,H11,H13,H14,H17,H18,H24,H25, H26,H27,MMM	16
9	PFOZZ	2540011883675	19207	12339047-1	SUPPORT,SEAT,VEHICU L.H..... UOC:A11,A13,A14,A24,A25,A26,A27,B24, B25,C17,H11,H13,H14,H17,H18,H24,H25, H26,H27,MMM	1
9	PFOZZ	2540011854387	19207	12339047-2	SUPPORT,SEAT,VEHICU R.H..... UOC:A11,A13,A14,A20,A24,A25,A26,A27, B24,B25,C17,H11,H13,H14,H17,H18,H20, H24,H25,H26,H27,MMM	1
10	PAOZZ	2540012030183	72658	E06879-00	BELT,VEHICULAR SAFE REAR,USBL EFF 1 THRU 99,999..... UOC:H11,H13,H14,H17,H18,H24,H25,H26, H27,MMM	2
11	PAOZZ	5306014490510	19207	12340259-12	BOLT,SHOULDER FOR REPAIR ONLY,USE WITH ITEMS 12 AND 19,7/16-20X1.01 USBL FEE 1 THRU 99,999..... UOC:H11,H13,H14,H17,H18,H20,H24,H25,	2

SECTION II			TM9-2320-280-24P			
(1)	(2)	(3)	(4)	(5)	(6)	(7)
ITEM NO	SMR CODE	NSN	CAGEC	PART NUMBER	DESCRIPTION AND USABLE ON CODES(UOC)	QTY
12	PAOZZ	5310012538437	19207	12340058	H26,H27,MMM WASHER,FLAT USBL EFF 1 THRU 99,999. UOC:H11,H13,H14,H17,H18,H24,H25,H26, H27,MMM	4
13	PAOZZ	5310013153403	24617	9442938	NUT,SELF-LOCKING,HE 7/16-20..... UOC:H11,H17,H18,H24,H25,H26,H27	4
14	PAOZZ	5340012426245	99017	W-4	CAP-PLUG,PROTECTIVE..... UOC:H15,H16,H21,H28	2
15	PAOZZ	5306014505947	19207	12340259-10	BOLT,SHOULDER FOR REPAIR ONLY,USE WITH ITEMS 12 AND 19 7/16-20X1.31... UOC:H11,H13,H14,H17,H18,H20,H24,H25, H26,H27,MMM	2
16	PAOZZ	5340011971294	29372	20L01-1-1AF	CATCH,CLAMPING..... UOC:A11,A13,A14,A24,A25,A26,A27,B24, B25,C17,H11,H13,H14,H17,H18,H24,H25, H26,H27,MMM	4
17	PAOZZ	5320012544251	34623	5593050	RIVET,BLIND 3/16 DIA..... UOC:A11,A13,A14,A24,A25,A26,A27,B24, B25,C17,H11,H13,H14,H17,H18,H24,H25, H26,H27,MMM	8
18	PAOZZ	5320011384239	11815	CR3213-4-3	RIVET,BLIND 1/8 DIA..... UOC:A11,A13,A14,A24,A25,A26,A27,B24, B25,C17,H11,H13,H14,H17,H18,H24,H25, H26,H27,MMM	8
19	PAOZZ	5340010874612	71286	20L02-1-1AA	STRIKE,CATCH..... UOC:A11,A13,A14,A24,A25,A26,A27,B24, B25,C17,H11,H13,H14,H17,H18,H24,H25, H26,H27,MMM	4

END OF FIGURE

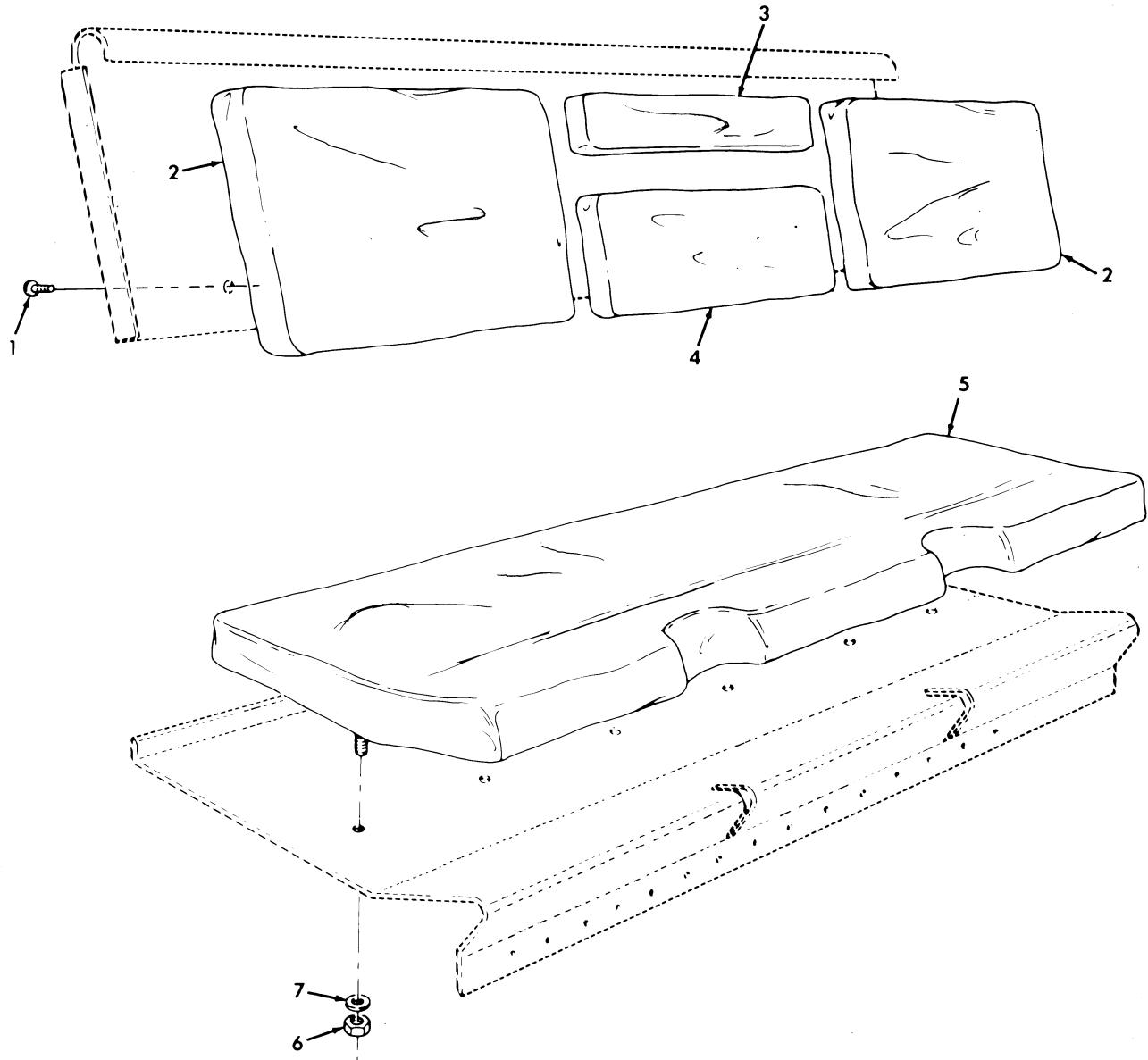

Figure 236. Seat Cushions and Mounting Hardware, M996 and M996A1 Ambulance.



SECTION II			TM9-2320-280-24P			
(1)	(2)	(3)	(4)	(5)	(6)	(7)
ITEM	SMR			PART		
NO	CODE	NSN	CAGEC	NUMBER	DESCRIPTION AND USABLE ON CODES(UC)	QTY
					GROUP 1806 UPHOLSTERY SEATS AND CARPET	
					FIG. 236 SEAT CUSHIONS AND MOUNTING HARDWARE,M996 AND M996A1 AMBULANCE	
1	PAOZZ	5305000593660	96906	MS51958-64	SCREW,MACHINE #10-32 X 5/8.....	24
					UOC:B16,H16	
2	PAOZZ	2540012713828	19207	12341450	CUSHION,SEAT,BACK V.....	4
					UOC:B16,H16	
3	PAOZZ	2540012706537	19207	12341451	CUSHION,SEAT BACK,V REAR SEAT BACK, CENTER,UPPER.....	2
					UOC:B16,H16	
4	PAOZZ	2540012706538	19207	12341452	CUSHION,SEAT BACK,V.....	2
					UOC:B16,H16	
5	PAOZZ	2540012706539	19207	12341555	CUSHION,SEAT VEHICU.....	2
					UOC:B16,H16	
6	PAOZZ	5310008807744	96906	MS51967-5	NUT,PLAIN,HEXAGON 5/16 X 18.....	24
					UOC:B16,H16	
7	PAOZZ	5310000814219	96906	MS27183-12	WASHER,FLAT 5/16.....	24
					UOC:B16,H16	

END OF FIGURE

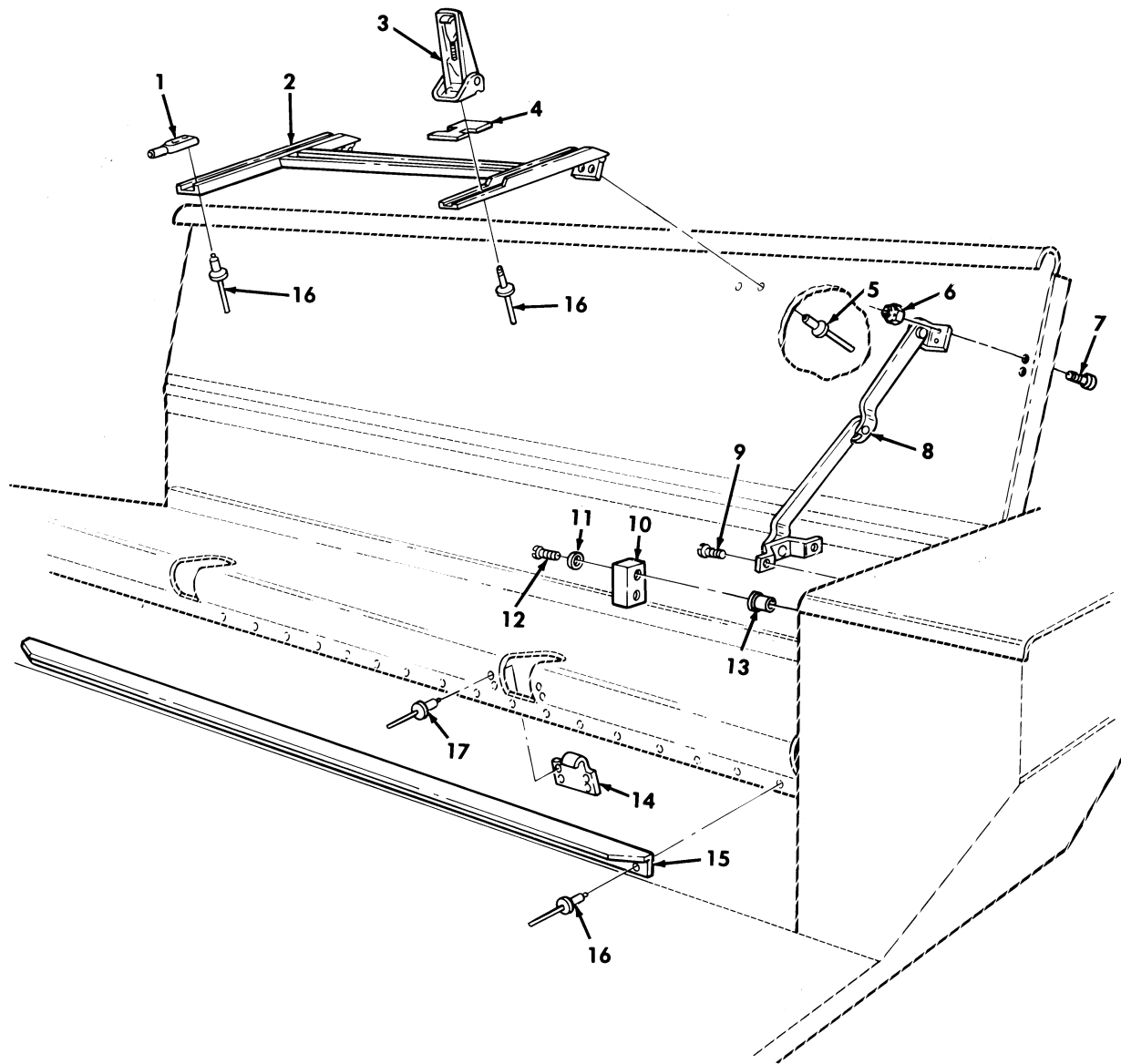

Figure 237. Seat Frame Assembly and Related Hardware, M996 and M996A1 Ambulance.

SECTION II			TM9-2320-280-24P			
(1)	(2)	(3)	(4)	(5)	(6)	(7)
ITEM	SMR			PART		
NO	CODE	NSN	CAGEC	NUMBER	DESCRIPTION AND USABLE ON CODES(UOC)	QTY
GROUP 1806 UPHOLSTERY SEATS AND CARPET						
FIG. 237 SEAT FRAME ASSEMBLY AND RELATED HARDWARE,M996 AND M996A1 AMBULANCE						
1	PAOZZ	5340012763615	19207	12339011	STRIKER,LATCH REAR.....	4
					UOC:B16,H16	
2	PAOZZ	2540012706540	34623	12341206	FRAME,SEAT,VEHICULA R.H.....	1
					UOC:B16,H16	
2	PAOZZ	2540012706541	19207	12341205	FRAME,SEAT,VEHICULA L.H.....	1
					UOC:B16,H16	
3	PAOZZ	5342010360649	71286	51L3-1-1-AA	LATCH REAR.....	4
					UOC:B16,H16	
4	PAOZZ	5365012724866	19207	12341324	SPACER,PLATE REAR.....	4
					UOC:B16,H16	
5	PAOZZ	5320012597423	11815	CR-213-4-5	RIVET,BLIND 1/8.....	8
					UOC:B16,H16	
6	PAOZZ	5310012552695	34623	5593035	NUT,SELF-LOCKING,HE 1/4-20.....	8
					UOC:B16,H16	
7	PAOZZ	5305009881724	96906	MS35206-280	SCREW,MACHINE 1/4-20 X .62.....	8
					UOC:B16,H16	
8	PAOZZ	5340012729103	03007	7792RH02	STAY,FOLDING FRONT L.H.....	2
					UOC:B16,H16	
8	PAOZZ	2540012715072	03007	7792 LH-02	BRACE,SEAT BACK REA FRONT R.H.....	2
					UOC:B16,H16	
9	PAOZZ	5305000712067	80204	B1821BH050C125N	SCREW,CAP,HEXAGON H 1/2-13 X 1.25..	8
					UOC:B16,H16	
10	PAOZZ	5365012724867	19207	12341332	SPACER,PLATE.....	4
					UOC:B16,H16	
11	PAOZZ	5310005825965	96906	MS35338-44	WASHER,LOCK 1/4.....	8
					UOC:B16,H16	
12	PAOZZ	5305009881171	96906	MS35206-285	SCREW,MACHINE 1/4-20 X 1.50.....	8
					UOC:B16,H16	
13	PAOZZ	5310004015321	96906	MS27130A32	NUT,PLAIN,BLIND RIV .275-.350 GRIP.	4
					UOC:B16,H16	
14	PAOZZ	5340012743184	19207	12341299	STRIKE,CATCH REAR.....	4
					UOC:B16,H16	
15	PAOZZ	2540012761451	19207	12341113	SUPPORT,SEAT,VEHICU.....	2
					UOC:B16,H16	
16	PAOZZ	5320012596155	34623	5575936	RIVET,SOLID 3/16.....	32
					UOC:B16,H16	
17	PAOZZ	5320011357319	11815	CR-213-6-3	RIVET,BLIND 3/16.....	16
					UOC:B16,H16	

END OF FIGURE

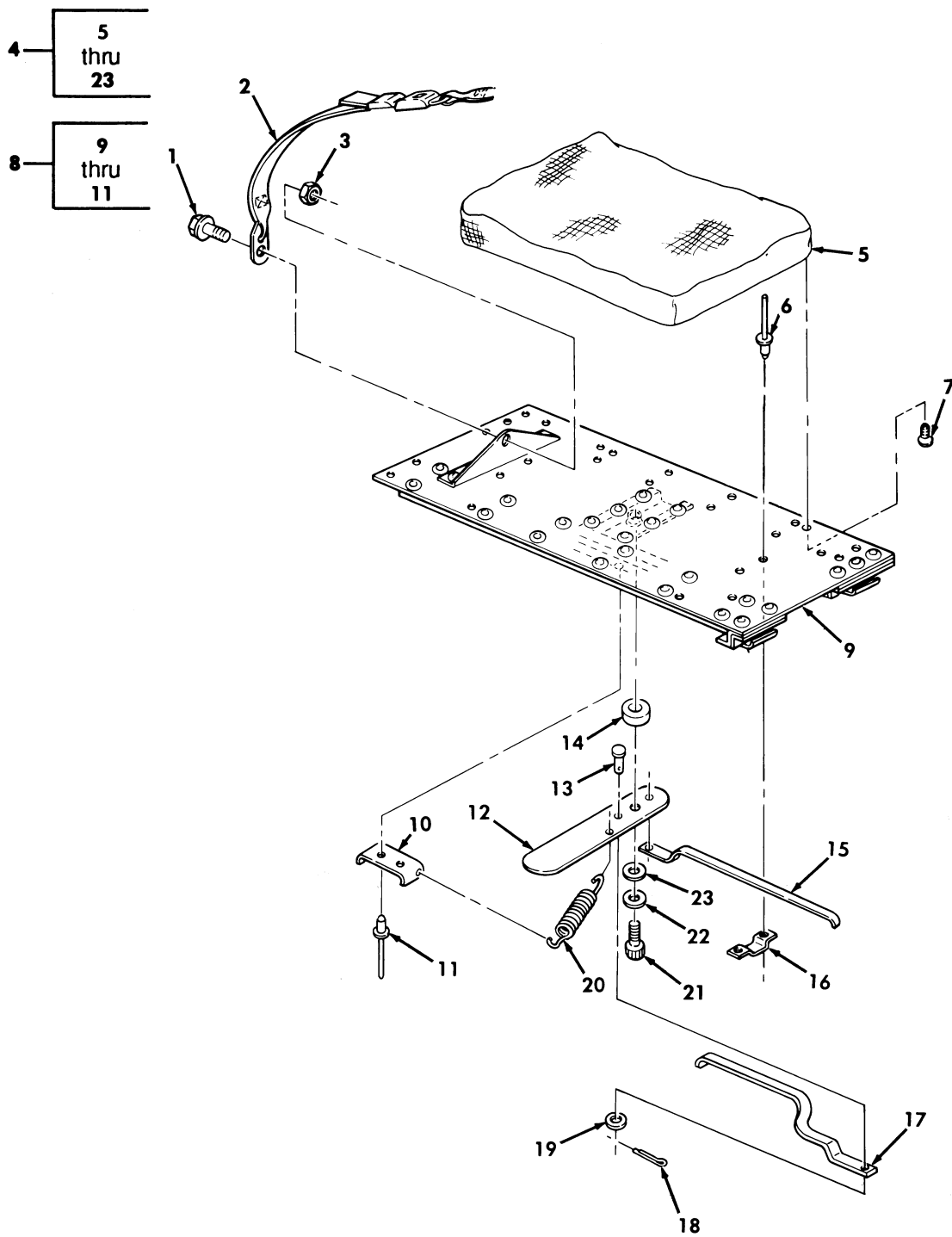

Figure 238. Attendant Seat, M996, M996A1, M997, M997A1, and M997A2 Ambulance.

SECTION II			TM9-2320-280-24P			
(1)	(2)	(3)	(4)	(5)	(6)	(7)
ITEM NO	SMR CODE	NSN	CAGEC	PART NUMBER	DESCRIPTION AND USABLE ON CODES(UOC)	QTY
					GROUP 1806 UPHOLSTERY SEATS AND CARPET	
					FIG. 238 ATTENDANT SEAT,M996,M996A1, M997,M997A1,AND M997A2 AMBULANCE	
1	PAOZZ	5305012542522	19207	12340259	SCREW,CAP,HEXAGON H 7/16-20.....	2
					UOC:A15,B15,B16,H15,H16	
2	PAOZZ	5340012658922	19207	12341802	STRAP,WEBBING.....	1
					UOC:A15,B15,B16,H15,H16	
3	PAOZZ	5310002749364	96906	MS21045-7	NUT,SELF-LOCKING,HE 7/16-20.....	2
					UOC:A15,B15,B16,H15,H16	
4	PAOOO	2540012709711	34623	12341246	SUPPORT,SEAT,VEHICU.....	1
					UOC:A15,B15,B16,H15,H16	
5	PAOZZ	2540012705065	19207	12341133	.CUSHION,SEAT,VEHICU.....	1
					UOC:A15,B15,B16,H15,H16	
6	PAOZZ	5320007540992	80205	MS20470AD6-7	.RIVET,SOLID.....	4
					UOC:A15,B15,B16,H15,H16	
7	PAOZZ	5305012729959	34623	5588927	.SCREW,WOOD #10-16 X .75.....	4
					UOC:A15,B15,B16,H15,H16	
8	XBOZZ		19207	12341138	.BASE,ATTENDANT SEAT.....	1
					UOC:A15,B15,B16,H15,H16	
9	PFOZZ	2540012718009	19207	12341135	..SUPPORT,SEAT,VEHICU.....	1
					UOC:A15,B15,B16,H15,H16	
10	PFOZZ	3040012707917	19207	12340958	..BRACKET,LEVER.....	1
					UOC:A15,B15,B16,H15,H16	
11	PAOZZ	5320011361782	80205	NAS9301BNS-6-04	..RIVET,BLIND 3/16 X 1/4.....	6
					UOC:A15,B15,B16,H15,H16	
12	PFOZZ	5340012726633	34623	5592010	.HANDLE,MANUAL CONTR.....	1
					UOC:A15,B15,B16,H15,H16	
13	PAOZZ	5315004175223	96906	MS35810-1	.PIN,STRAIGHT,HEADED 3/16.....	2
					UOC:A15,B15,B16,H15,H16	
14	PAOZZ	5310012725470	34623	5593597	.WASHER,FLAT.....	1
					UOC:A15,B15,B16,H15,H16	
15	PFOZZ	3040012707961	34623	5592013	.CONNECTING LINK,RIG L.H.....	1
					UOC:A15,B15,B16,H15,H16	
16	PFOZZ	5340012749899	34623	5589581	.STRIKE,CATCH.....	2
					UOC:A15,B15,B16,H15,H16	
17	PFOZZ	3040012713824	19207	12340994-1	.CONNECTING LINK,RIG.....	1
					UOC:A15,B15,B16,H15,H16	
18	PAOZZ	5315008392325	80205	MS24665-132	.PIN,COTTER 1/16 X 1/2.....	2
					UOC:A15,B15,B16,H15,H16	
19	PAOZZ	5310008094058	96906	MS27183-10	.WASHER,FLAT 9/32.....	2
					UOC:A15,B15,B16,H15,H16	
20	PAOZZ	5360012789723	34623	5592011	.SPRING,HELICAL,EXTE.....	1
					UOC:A15,B15,B16,H15,H16	
21	PAOZZ	5305000545642	96906	MS51957-8	.SCREW,MACHINE 1/4-20 X 1/2.....	1
					UOC:A15,B15,B16,H15,H16	
22	PAOZZ	5310000877493	96906	MS27183-13	.WASHER,FLAT 3/8.....	1
					UOC:A15,B15,B16,H15,H16	
23	PAOZZ	5310012727449	19207	12341353-1	.WASHER,FLAT 3/8.....	1
					UOC:A15,B15,B16,H15,H16	

END OF FIGURE

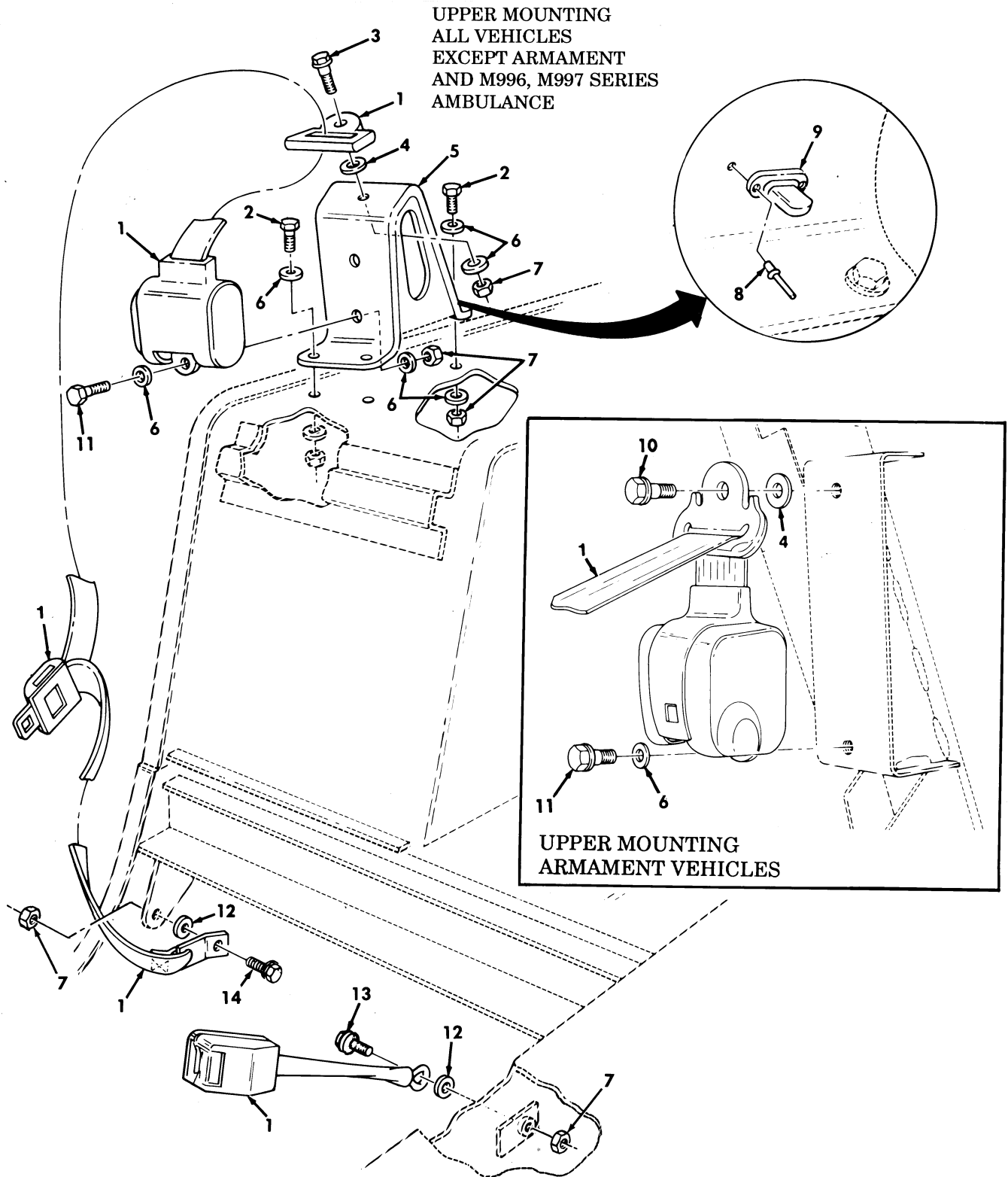

Figure 239. Rear Seatbelts, Brackets, and Mounting Hardware.

SECTION II			TM9-2320-280-24P			
(1)	(2)	(3)	(4)	(5)	(6)	(7)
ITEM NO	SMR CODE	NSN	CAGEC	PART NUMBER	DESCRIPTION AND USABLE ON CODES(UC)	QTY
					GROUP 1806 UPHOLSTERY SEATS AND CARPET	
					FIG. 239 REAR SEATBELTS, BRACKETS, AND MOUNTING HARDWARE	
1	PAOZZ	2540013153143	29944	F07011	BELT, VEHICULAR SAFE REAR LEFT AND RIGHT, USBL EFF 100,000 AND ABOVE.... UC:AVY, A11, A13, A14, A20, A24, A25, A26, A27, BVY, B17, B18, B20, B24, B25, C17, HVY, H11, H13, H14, H17, H18, H20, H24, H25, H26, H27, MMM, NNN	2
2	PAOZZ	5305013157066	24617	453719	SCREW, CAP, HEXAGON H 7/16-20 X 1.25, USBL EFF 100,000 AND ABOVE..... UC:AVY, A11, A13, A14, A20, A24, A27, BVY, B20, HVY, H11, H13, H14, H20, H24, H27, MMM, NNN	8
3	PAOZZ	5306013157087	19207	12340259-5	BOLT, SHOULDER 7/16-20 X 1.25, USBL EFF 100,000 AND ABOVE..... UC:AVY, A11, A13, A14, A20, A24, A27, BVY, B24, HVY, H11, H13, H14, H20, H24, H27, MMM, NNN	2
4	PAOZZ	5310012866077	19207	12341856	WASHER, FLAT 7/16-20, USBL EFF 100,000 AND ABOVE..... UC:AVY, A11, A13, A14, A20, A24, A25, A26, A27, BVY, B17, B18, B20, B24, B25, C17, HVY, H11, H13, H14, H17, H18, H20, H24, H25, H26, H27, MMM, NNN	2
5	PAOZZ	5340013342887	19207	12342374	BRACKET, MOUNTING USBL EFF 100,000 AND ABOVE..... UC:AVY, A11, A13, A14, A20, A24, A27, BVY, B20, B24, HVY, H11, H13, H14, H20, H24, H27, MMM, NNN	2
6	PAOZZ	5310008094085	96906	MS27183-16	WASHER, FLAT 7/16, USBL EFF 100,000 AND ABOVE..... UC:AVY, A11, A13, A14, A20, A24, A25, A27, BVY, B20, B24, HVY, H11, H13, H14, H20, H24, H27, MMM, NNN	12
6	PAOZZ	5310008094085	96906	MS27183-16	WASHER, FLAT 7/16, USBL EFF 100,000 AND ABOVE..... UC:A11, A20, A24, A25, A26, A27, B17, B18, B20, B24, B25, C17, H11, H17, H18, H20, H24, H25, H26, H27, MMM	2
7	PAOZZ	5310013153403	24617	9442938	NUT, SELF-LOCKING, HE 7/16-20, USBL EFF 100,000 AND ABOVE..... UC:AVY, A11, A13, A14, A20, A24, A27, BVY, B20, B24, HVY, H11, H13, H14, H20, H24, H27, MMM, NNN	6
8	PAOZZ	5320010298205	81349	M24243/1-A405	RIVET, BLIND 1/4, USBL EFF 100,000 AND ABOVE..... UC:AVY, A11, A13, A14, A20, A24, A27, BVY, B20, B24, HVY, H11, H13, H14, H20, H24, H27, MMM, NNN	4

SECTION II			TM9-2320-280-24P			
(1)	(2)	(3)	(4)	(5)	(6)	(7)
ITEM NO	SMR CODE	NSN	CAGEC	PART NUMBER	DESCRIPTION AND USABLE ON CODES(UC)	QTY
9	PAOZZ	5325008235999	13940	XB78323-05001	STUD,TURNBUTTON FAS USBL EFF 100,000 AND ABOVE..... UC:AVY,A11,A13,A14,A20,A24,A27,BVY,B20,B24,HVY,H11,H13,H14,H20,H24,H27,MMM,NNN	2
10	PAOZZ	5306013162433	19207	12340259-7	BOLT,SHOULDER 7/16-20 X 1.00 USBL EFF 100,000 AND ABOVE..... UC:A25,A26,A27,B17,B18,B25,C17,H17,H18,H25,H26	2
11	PAOZZ	5306011857052	7X677	9419293	BOLT,MACHINE 7/16-20 X 1.00,USBL EFF 100,000 AND ABOVE..... UC:A25,A26,B17,B18,B25,C17,H17,H18,H25,H26	2
12	PAOZZ	5310012538437	19207	12340058	WASHER,FLAT 7/16,USBLE EFF 100,000 AND ABOVE..... UC:AVY,A11,A13,A14,A20,A24,A27,BVY,B20,B24,HVY,H11,H13,H14,H20,H24,H27,MMM,NNN	4
13	PAOZZ	5306014378056	19207	12340259-11	BOLT,SHOULDER FOR REPAIR ONLY,USE WITH ITEMS 7 AND 12,REAR SEAT BELTS 7/16-20 X 1.47 USBL EFF 100,000 AND ABOVE..... UC:AVY,A11,A13,A14,A20,A24,A27,BVY,B20,B24,HVY,H11,H13,H14,H20,H24,H27,MMM,NNN	2
14	PAOZZ	5306014378058	19207	12340259-13	BOLT,SHOULDER FOR REPAIR ONLY,USE WITH ITEMS 7 AND 12,REAR SEAT BELTS 7/16-20 X 1.03 USBL EFF 100,000 AND ABOVE..... UC:AVY,A11,A13,A14,A20,A24,A27,BVY,B20,B24,HVY,H11,H13,H14,H20,H24,H27,MMM,NNN	2

END OF FIGURE



8 — 9  
thru  
24

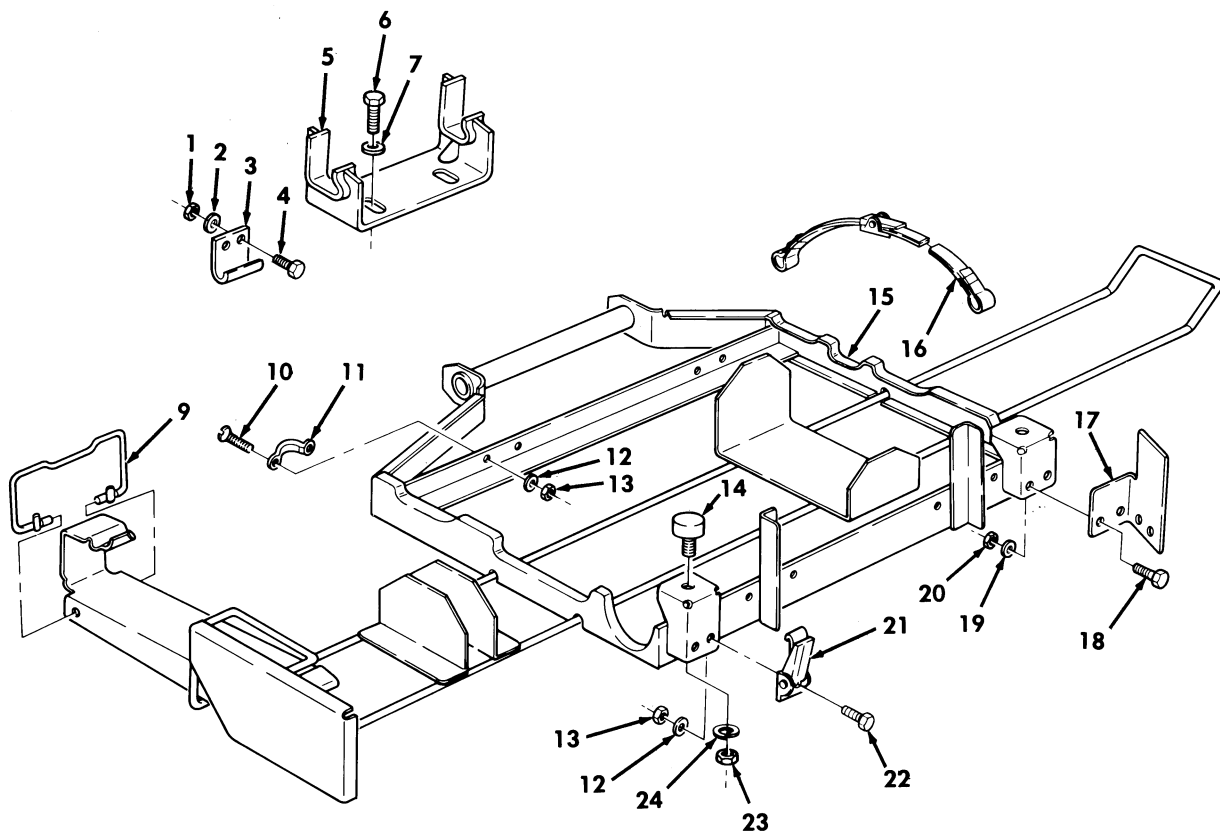
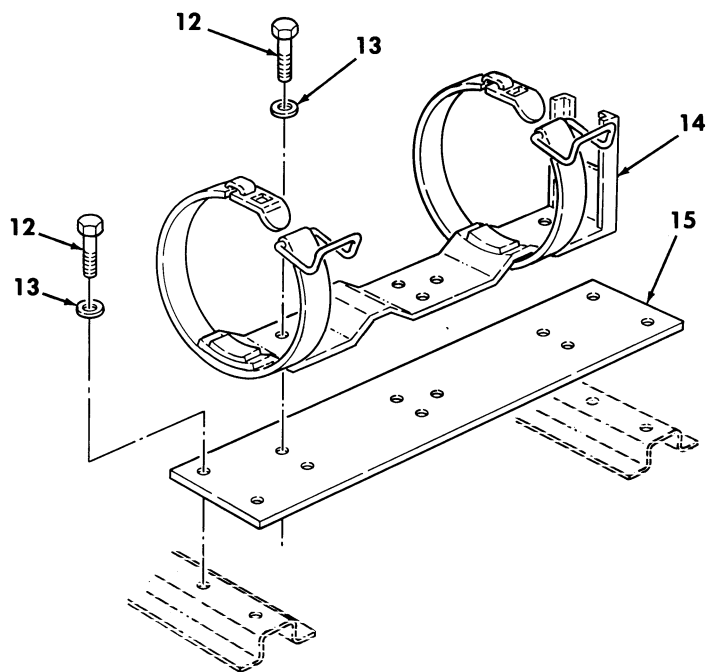
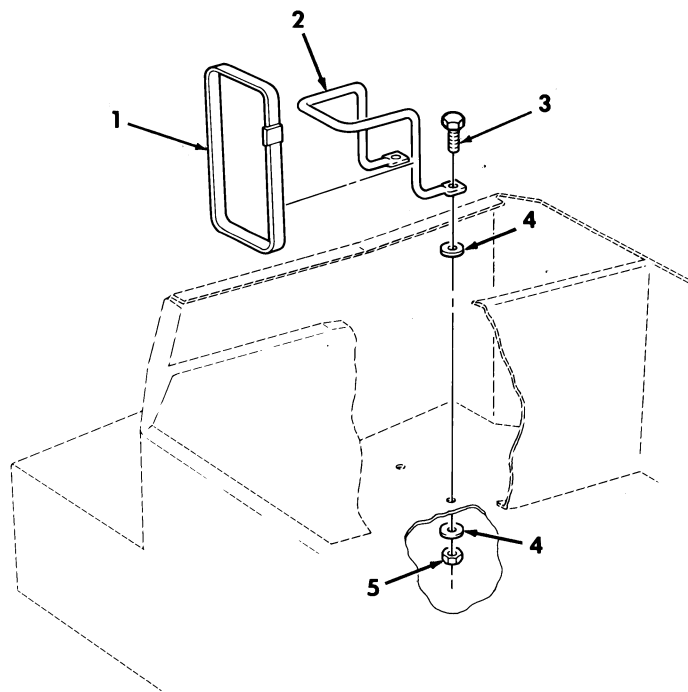

Figure 240. Pioneer Tool Stowage Tray Assembly.

SECTION II			TM9-2320-280-24P			
(1)	(2)	(3)	(4)	(5)	(6)	(7)
ITEM NO	SMR CODE	NSN	CAGEC	PART NUMBER	DESCRIPTION AND USABLE ON CODES(UC)	QTY
					GROUP 1808 STOWAGE RACKS,BOXES, STRAPS,CARRYINGCASES,CABLE REELS, HOSE REELS	
					FIG. 240 PIONEER TOOL STOWAGE TRAY ASSEMBLY	
1	PAOZZ	5310009349758	96906	MS35649-202	NUT,PLAIN,HEXAGON #10-24.....	4
2	PAOZZ	5310005845272	02978	ERNA245	WASHER,LOCK #10.....	4
3	PAOZZ	5340012559380	71286	18L13-1-AD	STRIKE,CATCH.....	2
4	PAOZZ	5305011858674	7X677	9421294	SCREW,CAP,HEXAGON H #10-24 X 1/2...	4
5	PFOZZ	2590011883237	19207	12340286	BRACKET,TOOL TRAY FRONT.....	1
6	PAOZZ	5305005434372	80204	B1821BH038C075N	SCREW,CAP,HEXAGON H 3/8-16 X 3/4...	2
7	PAOZZ	5310000877493	96906	MS27183-13	WASHER,FLAT 3/8.....	2
8	PFOZZ	2540011856119	34623	12340288	TRAY,TOOL STOWAGE,V.....	1
					UC:A11,A13,A14,A20,A24,A25,A26,A27, B17,B18,B20,B24,B25,C17,H11,H13,H14, H17,H18,H20,H24,H25,H26,H27,MMM	
8	PFOZZ	2540012233749	34623	12340289	BOX,ACCESSORIES STO.....	1
					UC:AVY,A15,BVY,B15,B16,HVY,H15,H16, H21,H28,NNN	
9	PAOZZ	5340012104751	19207	12340271	.CLIP,RETAINING.....	1
10	PAOZZ	5305012532989	34623	5592838	.SCREW,MACHINE #10-24 X 1/2.....	8
11	PAOZZ	5340011918186	34623	5582608	.HANDLE,BOW.....	4
12	PAOZZ	5310005845272	02978	ERNA245	.WASHER,LOCK #10.....	12
13	PAOZZ	5310009349758	96906	MS35649-202	.NUT,PLAIN,HEXAGON #10-24.....	12
14	PAOZZ	5340012331461	13008	7168	.BUMPER,NONMETALLIC.....	2
					UC:AVY,A15,BVY,B15,B16,HVY,H15,H16, H21,H28,NNN	
14	PAOZZ	5340011858820	19207	12340846-1	.BUMPER,NONMETALLIC.....	2
					UC:A11,A13,A14,A20,A24,A25,A26,A27, B17,B18,B20,B24,B25,C17,H11,H13,H14, H17,H18,H20,H24,H25,H26,H27,MMM	
15	XAOZZ		34623	5578197	.TRAY ASSEMBLY.....	1
16	PAOZZ	2590011854390	31272	44672-11	.STRAP ASSEMBLY,TOOL LH.....	1
16	PAOZZ	2590011854391	31272	44672-10	.STRAP ASSEMBLY,TOOL RH.....	1
17	PAOZZ	5340012101606	19207	12340275-1	.BRACKET,ANGLE LH.....	1
					UC:AVY,A15,BVY,B15,B16,HVY,H15,H16, H21,H28,NNN	
17	PAOZZ	5340012134267	34623	5583235	.BRACKET,ANGLE RH.....	1
					UC:AVY,A15,BVY,B15,B16,HVY,H15,H16, H21,H28,NNN	
18	PAOZZ	5305011858674	7X677	9421294	.SCREW,CAP,HEXAGON H #10-24 X 1/2..	4
					UC:AVY,A15,BVY,B15,B16,HVY,H15,H16, H21,H28,NNN	
19	PAOZZ	5310000453296	96906	MS35338-43	.WASHER,LOCK #10.....	4
					UC:AVY,A15,BVY,B15,B16,HVY,H15,H16, H21,H28,NNN	
20	PAOZZ	5310009349758	96906	MS35649-202	.NUT,PLAIN,HEXAGON #10-24.....	4
					UC:AVY,A15,BVY,B15,B16,HVY,H15,H16, H21,H28,NNN	
21	PAOZZ	5340012065040	29372	18L01-1X1AA	.CATCH,CLAMPING.....	2
22	PAOZZ	5305011858674	7X677	9421294	.SCREW,CAP,HEXAGON H #10-24 X 1/2..	4

SECTION II			TM9-2320-280-24P			
(1)	(2)	(3)	(4)	(5)	(6)	(7)
ITEM	SMR			PART		
NO	CODE	NSN	CAGEC	NUMBER	DESCRIPTION AND USABLE ON CODES(UC)	QTY
23	PAOZZ	5310009050762	96906	MS51967-3	.NUT,PLAIN,HEXAGON 1/4-20.....	2
24	PAOZZ	5310005825965	96906	MS35338-44	.WASHER,LOCK 1/4.....	2

END OF FIGURE



**"A1" and "A2" Series**

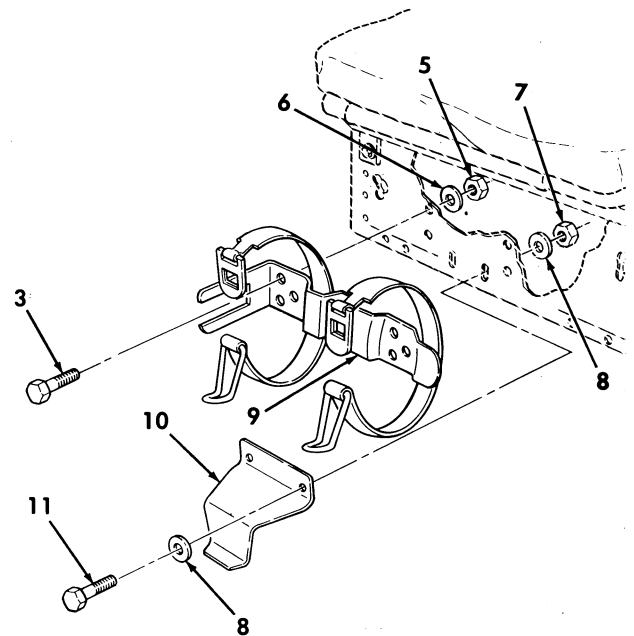

**Basic Series**

*Figure 241. First Aid Kit and Fire Extinguisher Mounting Brackets.*

SECTION II			TM9-2320-280-24P			
(1)	(2)	(3)	(4)	(5)	(6)	(7)
ITEM NO	SMR CODE	NSN	CAGEC	PART NUMBER	DESCRIPTION AND USABLE ON CODES(UOC)	QTY
GROUP 1808 STOWAGE RACKS,BOXES, STRAPS,CARRYING CASES,CABLE REELS, HOSE REELS						
FIG. 241 FIRST AID KIT AND FIRE EXTINGUISHER MOUNTING BRACKETS						
1	PAOZZ	5340012067780	31272	44647-11	STRAP,WEBBING.....	1
2	PFOZZ	5340012070610	31272	45160-10	HANDLE,BOW.....	1
3	PAOZZ	5305000680502	96906	MS90725-6	SCREW,CAP,HEXAGON H 1/4-20 X 3/4... UOC:AVY,A11,A13,A14,A15,A20,A24,A25, A26,A27,BVY,B15,B16,B17,B18,B20,B24, B25,C17,NNN	2
3	PAOZZ	5305000680502	96906	MS90725-6	SCREW,CAP,HEXAGON H 1/4-20 X 3/4... UOC:HVV,H11,H13,H14,H15,H16,H17,H18, H20,H21,H24,H25,H26,H27,H28,MMM	6
4	PAOZZ	5310011023270	24617	2436161	WASHER,FLAT 1/4.....	4
5	PAOZZ	5310000614650	96906	MS51943-31	NUT,SELF-LOCKING,HE 1/4-20..... UOC:AVY,A11,A13,A14,A15,A20,A24,A25, A26,A27,BVY,B15,B16,B17,B18,B20,B24, B25,C17,NNN	2
5	PAOZZ	5310000614650	96906	MS51943-31	NUT,SELF-LOCKING,HE 1/4-20..... UOC:HVV,H11,H13,H14,H15,H16,H17,H18, H20,H21,H24,H25,H26,H27,H28,MMM	6
6	PAOZZ	5310012520513	34623	5592916	WASHER,FLAT 1/4..... UOC:HVV,H11,H13,H14,H15,H16,H17,H18, H20,H21,H24,H25,H26,H27,H28,MMM	4
7	PAOZZ	5310009349758	96906	MS35649-202	NUT,PLAIN,HEXAGON #10-24..... UOC:HVV,H11,H13,H14,H15,H16,H17,H18, H20,H21,H24,H25,H26,H27,H28,MMM	2
8	PAOZZ	5310000145850	96906	MS27183-42	WASHER,FLAT #10..... UOC:HVV,H11,H13,H14,H15,H16,H17,H18, H20,H21,H24,H25,H26,H27,H28,MMM	4
9	PAOZZ	4210012595634	19207	12340842	BRACKET,FIRE EXTING..... UOC:HVV,H11,H13,H14,H15,H16,H17,H18, H20,H21,H24,H25,H26,H27,H28,MMM	1
10	PFOZZ	4210012040913	34623	5596025	BRACKET,FIRE EXTING..... UOC:HVV,H11,H13,H14,H15,H16,H17,H18, H20,H21,H24,H25,H26,H27,H28,MMM	1
11	PAOZZ	5305012532998	34623	5592814	SCREW,CAP,HEXAGON H #10-24 X 1/2... UOC:HVV,H11,H13,H14,H15,H16,H17,H18, H20,H21,H24,H25,H26,H27,H28,MMM	2
12	PAOZZ	5305000680508	80204	B1821BH025C075N	SCREW,CAP,HEXAGON H 1/4-20 X 3/4... UOC:AVY,A11,A13,A14,A15,A20,A24,A25, A26,A27,BVY,B15,B16,B17,B18,B20,B24, B25,C17,NNN	4
13	PAOZZ	5310008094058	96906	MS27183-10	WASHER,FLAT 1/4..... UOC:AVY,A11,A13,A14,A15,A20,A24,A25, A26,A27,BVY,B15,B16,B17,B18,B20,B24, B25,C17,NNN	4
14	PAOZZ	4210012595634	19207	12340842	BRACKET,FIRE EXTING..... UOC:AVY,A11,A13,A14,A15,A20,A24,A25, A26,A27,BVY,B15,B16,B17,B18,B20,B24,	1

SECTION II			TM9-2320-280-24P			
(1)	(2)	(3)	(4)	(5)	(6)	(7)
ITEM	SMR			PART		
NO	CODE	NSN	CAGEC	NUMBER	DESCRIPTION AND USABLE ON CODES(UC)	QTY
15	PAOZZ	5340014734800	19207	12446706	B25,C17,NNN PLATE,MOUNTING..... UC:AVY,A11,A13,A14,A15,A20,A24,A25, A26,A27,BVY,B15,B16,B17,B18,B20,B24, B25,C17,NNN	1

END OF FIGURE

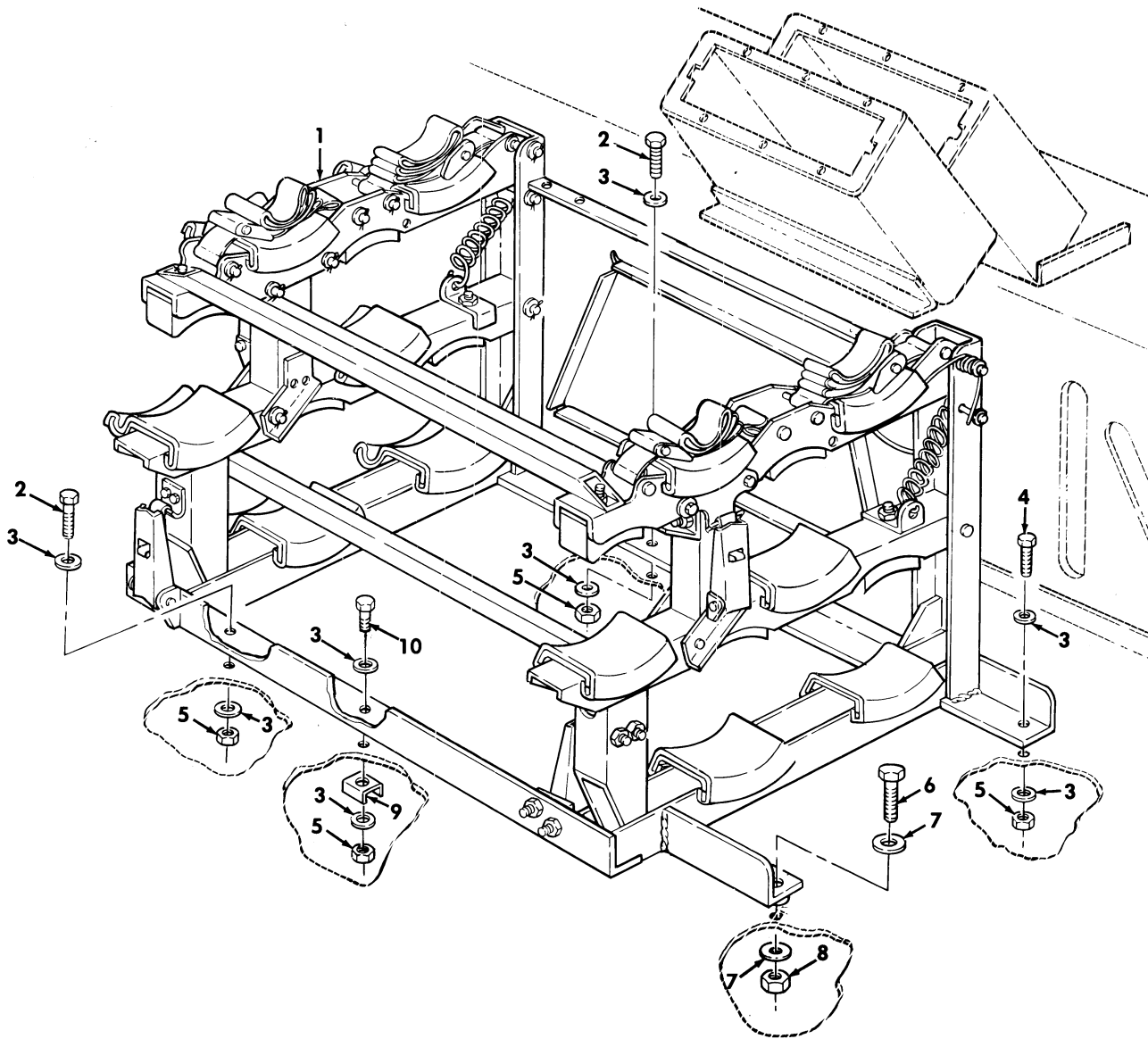

Figure 242. TOW Missile Rack Assembly and Mounting Hardware.

SECTION II			TM9-2320-280-24P			
(1)	(2)	(3)	(4)	(5)	(6)	(7)
ITEM	SMR			PART		
NO	CODE	NSN	CAGEC	NUMBER	DESCRIPTION AND USABLE ON CODES(UOC)	QTY
					GROUP 1808 STOWAGE RACKS,BOXES, STRAPS,CARRYING CASES,CABLE REELS, HOSE REELS	
					FIG. 242 TOW MISSILE RACK ASSEMBLY AND MOUNTING HARDWARE	
1	PFOOO	2540012468283	19207	12339821	RACK ASSEMBLY,MISSI.....	1
					UOC:A11,A24,A27,B24,H11,H24,H27,MMM	
2	PAOZZ	5305002264831	80204	B1821BH031C150N	SCREW,CAP,HEXAGON H 5/16-18 X 1.50.	3
					UOC:A11,A24,A27,B24,H11,H24,H27,MMM	
3	PAOZZ	5310012520512	34623	5592832	WASHER,FLAT 5/16.....	10
					UOC:A11,A24,A27,B24,H11,H24,H27,MMM	
4	PAOZZ	5306002264833	80204	B1821BH031C200N	BOLT,MACHINE 5/16-18 X 2.00.....	1
					UOC:A11,A24,A27,B24,H11,H24,H27,MMM	
5	PAOZZ	5310008140673	96906	MS51943-33	NUT,SELF-LOCKING,HE 5/16-18.....	5
					UOC:A11,A24,A27,B24,H11,H24,H27,MMM	
6	PAOZZ	5305000712070	80204	B1821BH050C175N	SCREW,CAP,HEXAGON H 1/2-13 X 1.75..	1
					UOC:A11,A24,A27,B24,H11,H24,H27,MMM	
7	PAOZZ	5310011211703	11862	2436165	WASHER,FLAT 1/2.....	2
					UOC:A11,A24,A27,B24,H11,H24,H27,MMM	
8	PAOZZ	5310004883889	96906	MS51943-39	NUT,SELF-LOCKING,HE 1/2-13.....	1
					UOC:A11,A24,A27,B24,H11,H24,H27,MMM	
9	PAOZZ	5340012477911	19207	12340569	BRACKET,MOUNTING.....	2
					UOC:A11,A24,A27,B24,H11,H24,H27,MMM	
10	PAOZZ	5306002264827	80204	B1821BH031C100N	BOLT,MACHINE 5/16-18 X 1.00.....	1
					UOC:A11,A24,A27,B24,H11,H24,H27,MMM	

END OF FIGURE



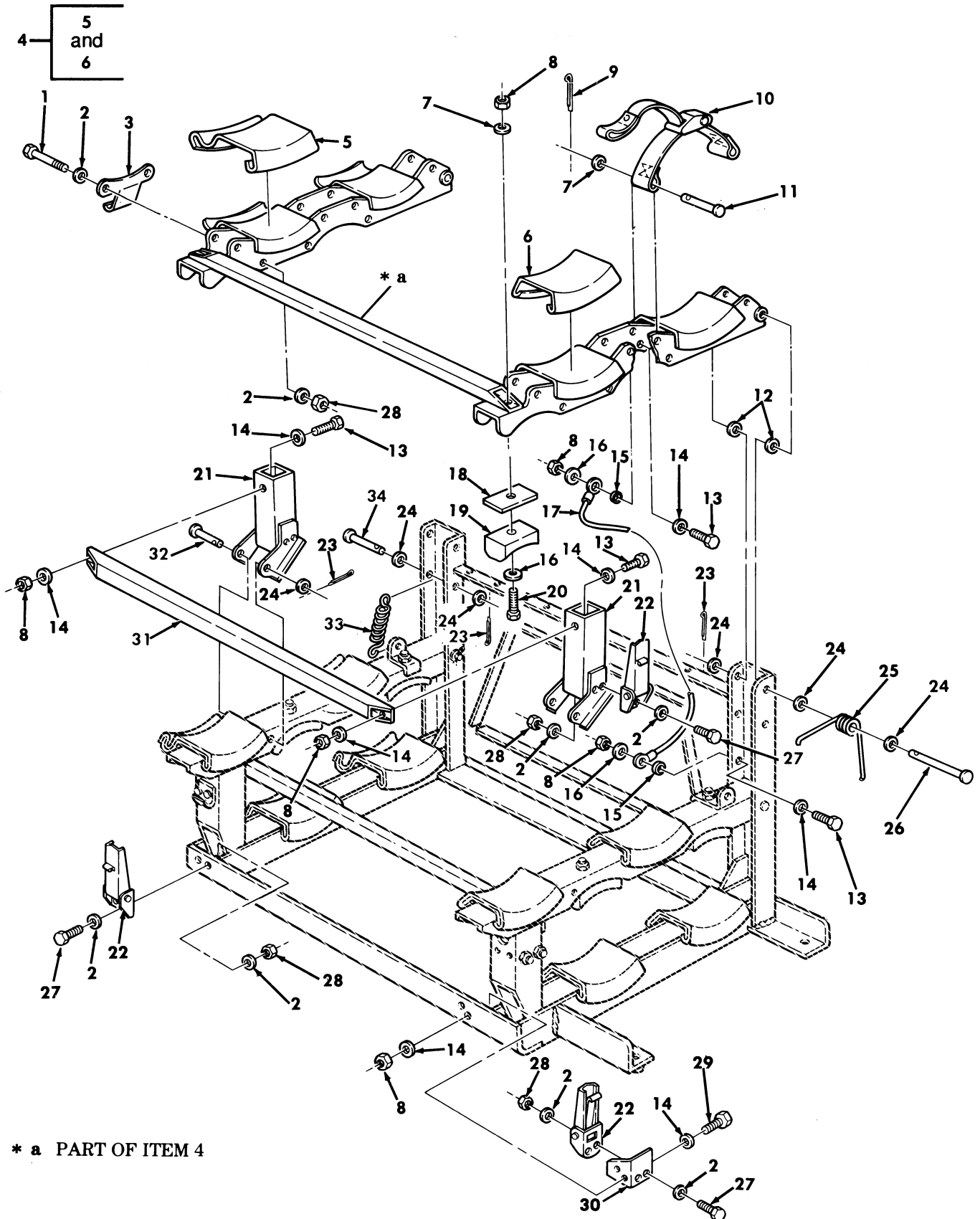

Figure 243. TOW Missile Rack Assembly, Upper Rack, Support, and Mounting Hardware.

SECTION II			TM9-2320-280-24P			
(1)	(2)	(3)	(4)	(5)	(6)	(7)
ITEM NO	SMR CODE	NSN	CAGEC	PART NUMBER	DESCRIPTION AND USABLE ON CODES(UCO)	QTY
					GROUP 1808 STOWAGE RACKS,BOXES, STRAPS,CARRYING CASES,CABLE REELS, HOSE REELS	
					FIG. 243 TOW MISSILE,RACK,ASSEMBLY, UPPER RACK,SUPPORT,AND MOUNTING HARDWARE	
1	PAOZZ	5305012552670	19207	12341815	SCREW,MACHINE #10-24 X 2.62.....	4
					UCO:A11,A24,A27,B24,H11,H24,H27,MMM	
2	PAOZZ	5310000145850	96906	MS27183-42	WASHER,FLAT #10.....	24
					UCO:A11,A24,A27,B24,H11,H24,H27,MMM	
3	PAOZZ	5340012564659	19207	12339760	STRIKE,CATCH UPPER.....	2
					UCO:A11,A24,A27,B24,H11,H24,H27,MMM	
4	PAOZZ	2540012468284	19207	12339819	RACK ASSEMBLY,MISSI UPPER.....	1
					UCO:A11,A24,A27,B24,H11,H24,H27,MMM	
5	PAOZZ	2590012358661	19207	12339778	.PAD,CUSHIONING REAR.....	2
					UCO:A11,A24,A27,B24,H11,H24,H27,MMM	
6	PAOZZ	2590011940309	19207	12340063	.PAD,CUSHIONING FRONT.....	2
					UCO:A11,A24,A27,B24,H11,H24,H27,MMM	
7	PAOZZ	5310008094058	96906	MS27183-10	WASHER,FLAT 1/4.....	16
					UCO:A11,A24,A27,B24,H11,H24,H27,MMM	
8	PAOZZ	5310000614650	96906	MS51943-31	NUT,SELF-LOCKING,HE 1/4-20.....	14
					UCO:A11,A24,A27,B24,H11,H24,H27,MMM	
9	PAOZZ	5315008395820	80205	MS24665-134	PIN,COTTER 1/16 X 3/4.....	8
					UCO:A11,A24,A27,B24,H11,H24,H27,MMM	
10	PAOZZ	5340012035634	31272	44647-10	STRAP,WEBBING.....	4
					UCO:A11,A24,A27,B24,H11,H24,H27,MMM	
11	PAOZZ	5315008409653	96906	MS20392-3C67	PIN,STRAIGHT,HEADED 1/4 X 2.29.....	8
					UCO:A11,A24,A27,B24,H11,H24,H27,MMM	
12	PAOZZ	5310012564491	86928	5610-140-62	WASHER,FLAT 5/16.....	4
					UCO:A11,A24,A27,B24,H11,H24,H27,MMM	
13	PAOZZ	5305000680508	80204	B1821BH025C075N	SCREW,CAP,HEXAGON H 1/4-20 X 3/4...	4
					UCO:A11,A24,A27,B24,H11,H24,H27,MMM	
14	PAOZZ	5310011023270	24617	2436161	WASHER,FLAT 1/4.....	10
					UCO:A11,A24,A27,B24,H11,H24,H27,MMM	
15	PAOZZ	5310011173446	21877	1851863-4	WASHER,FLAT.....	2
					UCO:A11,A24,A27,B24,H11,H24,H27,MMM	
16	PAOZZ	5310008093078	96906	MS27183-11	WASHER,FLAT 1/4.....	10
					UCO:A11,A24,A27,B24,H11,H24,H27,MMM	
17	PAOZZ	4010012030411	54979	HC-9.56	WIRE ROPE ASSEMBLY,.....	1
					UCO:A11,A24,A27,B24,H11,H24,H27,MMM	
18	PAOZZ	5365011962699	19207	12339767	SPACER,PLATE FRONT.....	4
					UCO:A11,A24,A27,B24,H11,H24,H27,MMM	
19	PAOZZ	5340011955397	34623	5579818	BUMPER,NONMETALLIC.....	8
					UCO:A11,A24,A27,B24,H11,H24,H27,MMM	
20	PAOZZ	5305010750957	96906	MS51849-100	SCREW,MACHINE 1/4-20 X 1.50.....	8
					UCO:A11,A24,A27,B24,H11,H24,H27,MMM	
21	PFOZZ	2510012524756	19207	12339784	FRAME SECTION,STRUC UPPER.....	2
					UCO:A11,A24,A27,B24,H11,H24,H27,MMM	
22	PAOZZ	5340012065040	29372	18L01-1X1AA	CATCH,CLAMPING.....	4
					UCO:A11,A24,A27,B24,H11,H24,H27,MMM	
23	PAOZZ	5315008423044	80205	NASM24665-283	PIN,COTTER 3/32 X 3/4.....	6

SECTION II			TM9-2320-280-24P			
(1)	(2)	(3)	(4)	(5)	(6)	(7)
ITEM	SMR			PART		
NO	CODE	NSN	CAGEC	NUMBER	DESCRIPTION AND USABLE ON CODES(UOC)	QTY
24	PAOZZ	5310000814219	96906	MS27183-12	UOC:A11,A24,A27,B24,H11,H24,H27,MMM WASHER,FLAT 5/16.....	10
25	PAOZZ	5360011956200	34623	5584854	UOC:A11,A24,A27,B24,H11,H24,H27,MMM SPRING,HELICAL,TORS.....	2
26	PAOZZ	5315012552764	34623	5596460	UOC:A11,A24,A27,B24,H11,H24,H27,MMM PIN,STRAIGHT,HEADED 5/16 X 4.00....	2
27	PAOZZ	5305010056715	96906	MS51849-77	UOC:A11,A24,A27,B24,H11,H24,H27,MMM SCREW,MACHINE #10-24 X .88.....	8
28	PAOZZ	5310002081918	88044	AN365-1024A	UOC:A11,A24,A27,B24,H11,H24,H27,MMM NUT,SELF-LOCKING,HE #10-24.....	12
29	PAOZZ	5305009543937	80205	MS35190-290	UOC:A11,A24,A27,B24,H11,H24,H27,MMM SCREW,MACHINE 1/4-20 X 7/8.....	2
30	PAOZZ	5340012564515	19207	12339763	UOC:A11,A24,A27,B24,H11,H24,H27,MMM BRACKET,ANGLE LOWER FRONT.....	1
31	PAOZZ	9530012487621	34623	5593624	UOC:A11,A24,A27,B24,H11,H24,H27,MMM BAR,METAL UPPER.....	1
32	PAOZZ	5315002400251	96906	MS20392-4C77	UOC:A11,A24,A27,B24,H11,H24,H27,MMM PIN,STRAIGHT,HEADED 5/16 X 2.656...	2
33	PAOZZ	5360012552808	01568	E1000-105-3500M	UOC:A11,A24,A27,B24,H11,H24,H27,MMM SPRING,HELICAL,EXTE.....	2
34	PAOZZ	5315012552763	34623	5596459	UOC:A11,A24,A27,B24,H11,H24,H27,MMM PIN,STRAIGHT,HEADED 5/16 X 3.50....	2

END OF FIGURE

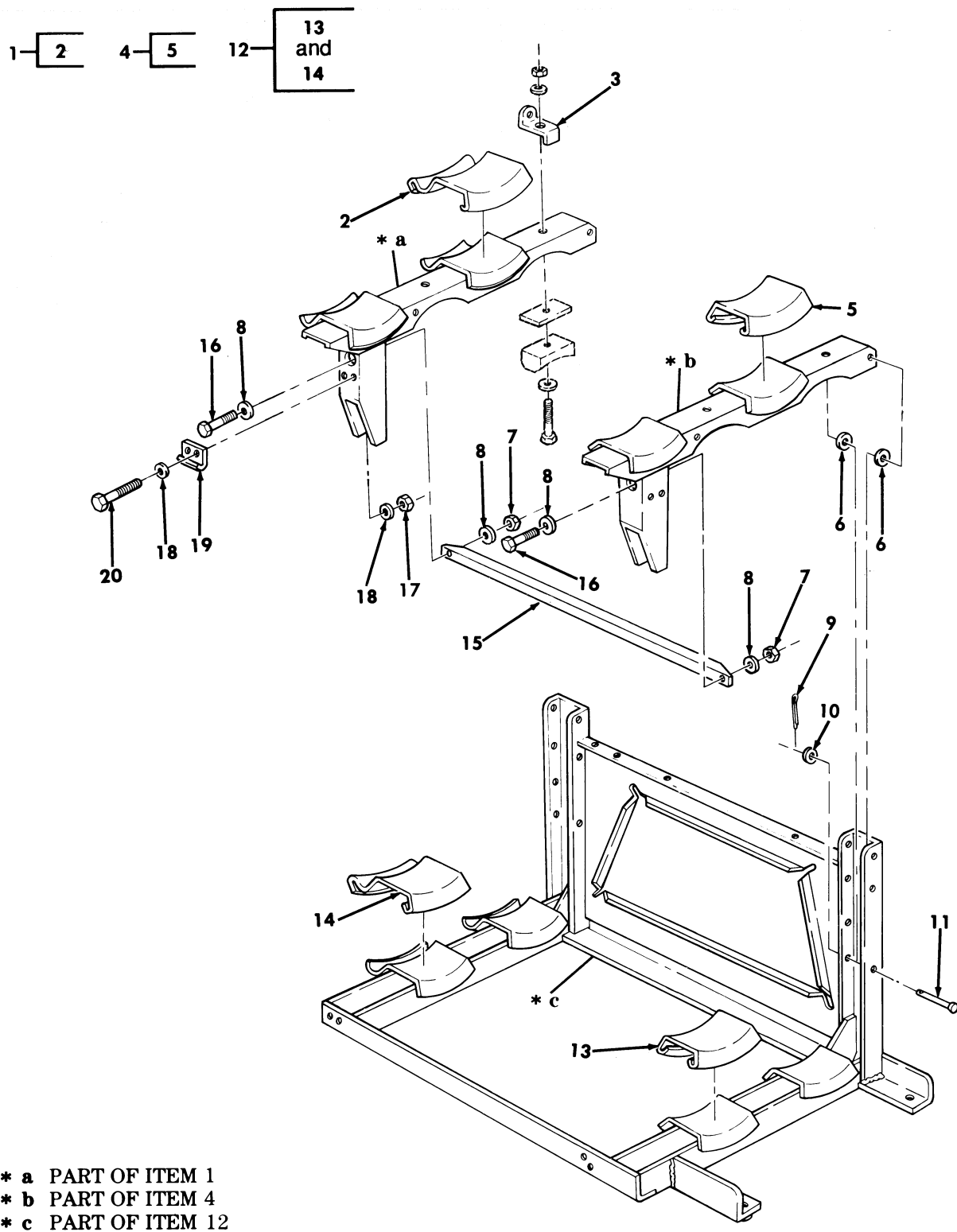

Figure 244. TOW Missile Rack Assembly, Intermediate Rack, and Base Assembly.

SECTION II			TM9-2320-280-24P			
(1)	(2)	(3)	(4)	(5)	(6)	(7)
ITEM NO	SMR CODE	NSN	CAGEC	PART NUMBER	DESCRIPTION AND USABLE ON CODES(UOC)	QTY
					GROUP 1808 STOWAGE RACKS,BOXES, STRAPS,CARRYING CASES,CABLE REELS, HOSE REELS	
					FIG. 244 TOW MISSILE RACK ASSEMBLY, INTERMEDIATE RACK,AND BASE ASSEMBLY	
1	PFOOO	2540012468285	34623	12339807	RACK ASSEMBLY,MISSI REAR.....	1
					UOC:A11,A24,A27,B24,H11,H24,H27,MMM	
2	PAOZZ	2590012358661	19207	12339778	.PAD,CUSHIONING REAR.....	2
					UOC:A11,A24,A27,B24,H11,H24,H27,MMM	
3	PFOZZ	5340012564516	19207	12339779	BRACKET,DOUBLE ANGL.....	2
					UOC:A11,A24,A27,B24,H11,H24,H27,MMM	
4	PAOOO	2540012468286	19207	12339806	RACK ASSEMBLY,MISSI FRONT.....	1
					UOC:A11,A24,A27,B24,H11,H24,H27,MMM	
5	PAOZZ	2590011940309	19207	12340063	.PAD,CUSHIONING FRONT.....	2
					UOC:A11,A24,A27,B24,H11,H24,H27,MMM	
6	PAOZZ	5310012564491	86928	5610-140-62	WASHER,FLAT.....	4
					UOC:A11,A24,A27,B24,H11,H24,H27,MMM	
7	PAOZZ	5310000614650	96906	MS51943-31	NUT,SELF-LOCKING,HE 1/4-20.....	2
					UOC:A11,A24,A27,B24,H11,H24,H27,MMM	
8	PAOZZ	5310011023270	24617	2436161	WASHER,FLAT 1/4.....	4
					UOC:A11,A24,A27,B24,H11,H24,H27,MMM	
9	PAOZZ	5315008423044	80205	NASM24665-283	PIN,COTTER 3/32 X 3/4.....	2
					UOC:A11,A24,A27,B24,H11,H24,H27,MMM	
10	PAOZZ	5310000814219	96906	MS27183-12	WASHER,FLAT 5/16.....	2
					UOC:A11,A24,A27,B24,H11,H24,H27,MMM	
11	PAOZZ	5315009890534	96906	MS20392-4C95	PIN,STRAIGHT,HEADED 5/16 X 3.219...	2
					UOC:A11,A24,A27,B24,H11,H24,H27,MMM	
12	PAOZZ	2590012491578	19207	12339820	RACK,AMMUNITION STO.....	1
					UOC:A11,A24,A27,B24,H11,H24,H27,MMM	
13	PAOZZ	2590011940309	19207	12340063	.PAD,CUSHIONING FRONT.....	2
					UOC:A11,A24,A27,B24,H11,H24,H27,MMM	
14	PAOZZ	2590012358661	19207	12339778	.PAD,CUSHIONING REAR.....	2
					UOC:A11,A24,A27,B24,H11,H24,H27,MMM	
15	PAOZZ	9530012487621	34623	5593624	BAR,METAL.....	1
					UOC:A11,A24,A27,B24,H11,H24,H27,MMM	
16	PAOZZ	5305000680502	96906	MS90725-6	SCREW,CAP,HEXAGON H 1/4-20 X 3/4...	2
					UOC:A11,A24,A27,B24,H11,H24,H27,MMM	
17	PAOZZ	5310002081918	88044	AN365-1024A	NUT,SELF-LOCKING,HE #10-24.....	4
					UOC:A11,A24,A27,B24,H11,H24,H27,MMM	
18	PAOZZ	5310000145850	96906	MS27183-42	WASHER,FLAT #10.....	8
					UOC:A11,A24,A27,B24,H11,H24,H27,MMM	
19	PAOZZ	5340011900815	71286	18L13-1-1AA	STRIKE,CATCH.....	2
					UOC:A11,A24,A27,B24,H11,H24,H27,MMM	
20	PAOZZ	5305012560405	34623	5593634	SCREW,MACHINE #10-24 X 2.50.....	4
					UOC:A11,A24,A27,B24,H11,H24,H27,MMM	

END OF FIGURE

Section II.

TM 9-2320-280-24P-1

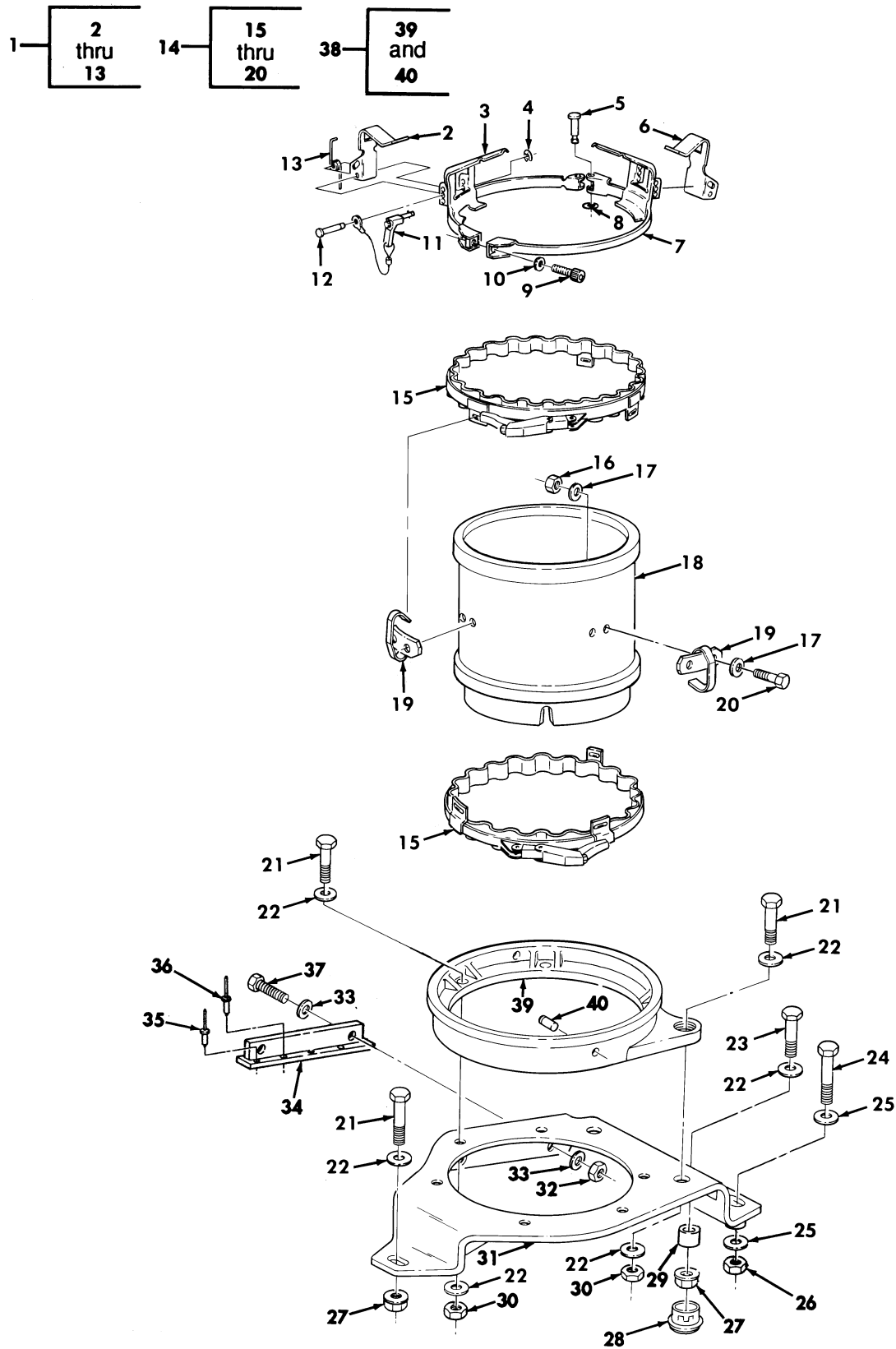

Figure 245. Traversing Unit Stowage and Depression Stop Assembly.

SECTION II			TM9-2320-280-24P			
(1)	(2)	(3)	(4)	(5)	(6)	(7)
ITEM	SMR			PART		
NO	CODE	NSN	CAGEC	NUMBER	DESCRIPTION AND USABLE ON CODES(UOC)	QTY
					GROUP 1808 STOWAGE RACKS,BOXES, STRAPS,CARRYING CASES,CABLE REELS, HOSE REELS	
					FIG. 245 TRAVERSING UNIT STOWAGE AND DEPRESSION STOP ASSEMBLY	
1	PAOOO	2590011885081	34623	5583676	STOP ASSEMBLY,ELEVA.....	1
					UOC:A11,A24,A27,B24,H11,H24,H27,MMM	
2	PAOZZ	5340011976715	34623	5584104	.BRACKET,MOUNTING.....	1
					UOC:A11,A24,A27,B24,H11,H24,H27,MMM	
3	PAOZZ	5340012035629	34623	5584135	.STRAP,RETAINING.....	1
					UOC:A11,A24,A27,B24,H11,H24,H27,MMM	
4	PAOZZ	5365011965636	11862	274612	.RING,RETAINING.....	2
					UOC:A11,A24,A27,B24,H11,H24,H27,MMM	
5	PAOZZ	5315011973122	19207	12340053	.PIN,GROOVED,HEADED.....	1
					UOC:A11,A24,A27,B24,H11,H24,H27,MMM	
6	PAOZZ	5340011976716	34623	5584105	.BRACKET.....	1
					UOC:A11,A24,A27,B24,H11,H24,H27,MMM	
7	PAOZZ	5340012035630	34623	5584136	.STRAP,RETAINING.....	1
					UOC:A11,A24,A27,B24,H11,H24,H27,MMM	
8	PAOZZ	5325011965631	7X677	11505885	.RING,RETAINING.....	1
					UOC:A11,A24,A27,B24,H11,H24,H27,MMM	
9	PAOZZ	5305012640923	96906	MS51480-05	.SCREW,CAP,SOCKET HE 1/4-28 X 1.50.	1
					UOC:A11,A24,A27,B24,H11,H24,H27,MMM	
10	PAOZZ	5310011023270	24617	2436161	.WASHER,FLAT 1/4.....	1
					UOC:A11,A24,A27,B24,H11,H24,H27,MMM	
11	PAOZZ	5315009738637	09094	903C4-16	.PIN,QUICK RELEASE.....	2
					UOC:A11,A24,A27,B24,H11,H24,H27,MMM	
12	PAOZZ	5315011983346	34623	5584107	.PIN,GROOVED,HEADED.....	2
					UOC:A11,A24,A27,B24,H11,H24,H27,MMM	
13	PAOZZ	5360011012143	83553	T048-270-250L	.SPRING,HELICAL,TORS.....	2
					UOC:A11,A24,A27,B24,H11,H24,H27,MMM	
14	PAOOO	2590011885079	19207	12339680	ADAPTER ASSEMBLY,TU.....	1
					UOC:A11,A24,A27,B24,H11,H24,H27,MMM	
15	PAOZZ	5342011047700	18876	13048915-1	.COUPLING,CLAMP,GROO.....	2
					UOC:A11,A24,A27,B24,H11,H24,H27,MMM	
16	PAOZZ	5310000614650	96906	MS51943-31	.NUT,SELF-LOCKING,HE 1/4-20.....	12
					UOC:A11,A24,A27,B24,H11,H24,H27,MMM	
17	PAOZZ	5310011023270	24617	2436161	.WASHER,FLAT 1/4.....	24
					UOC:A11,A24,A27,B24,H11,H24,H27,MMM	
18	XAOZZ		34623	5583120	.ADAPTER.....	1
					UOC:A11,A24,A27,B24,H11,H24,H27,MMM	
19	PAOZZ	5340011973478	34623	5583993	.CLIP,SPRING TENSION.....	6
					UOC:A11,A24,A27,B24,H11,H24,H27,MMM	
20	PAOZZ	5305000680502	96906	MS90725-6	.SCREW,CAP,HEXAGON H 1/4-20 X 3/4..	12
					UOC:A11,A24,A27,B24,H11,H24,H27,MMM	
21	PAOZZ	5305000680510	80204	B1821BH038C100N	SCREW,CAP,HEXAGON H 3/8-16 X 1.00..	9
					UOC:A11,A24,A27,B24,H11,H24,H27,MMM	
22	PAOZZ	5310000806004	96906	MS27183-14	WASHER,FLAT 3/8.....	18
					UOC:A11,A24,A27,B24,H11,H24,H27,MMM	
23	PAOZZ	5305007252317	80204	B1821BH038C150N	SCREW,CAP,HEXAGON H 3/8-16 X 1.50..	1
					UOC:A11,A24,A27,B24,H11,H24,H27,MMM	

SECTION II			TM9-2320-280-24P			
(1)	(2)	(3)	(4)	(5)	(6)	(7)
ITEM NO	SMR CODE	NSN	CAGEC	PART NUMBER	DESCRIPTION AND USABLE ON CODES(UOC)	QTY
24	PAOZZ	5305000712070	80204	B1821BH050C175N	SCREW,CAP,HEXAGON H 1/2-13 X 1.75.. UOC:A11,A24,A27,B24,H11,H24,H27,MMM	1
25	PAOZZ	5310001670823	88044	AN960-816	WASHER,FLAT 1/2..... UOC:A11,A24,A27,B24,H11,H24,H27,MMM	2
26	PAOZZ	5310004883889	96906	MS51943-39	NUT,SELF-LOCKING,HE 1/2-13..... UOC:A11,A24,A27,B24,H11,H24,H27,MMM	1
27	PAOZZ	5310012658968	34623	5591513	NUT,SELF-LOCKING,EX 3/8-16..... UOC:A11,A24,A27,B24,H11,H24,H27,MMM	2
28	PAOZZ	5340011104036	19207	12298661	PLUG,VENT..... UOC:A11,A24,A27,B24,H11,H24,H27,MMM	1
29	PFOZZ	5365012569568	19207	12339751	SPACER,SLEEVE..... UOC:A11,A24,A27,B24,H11,H24,H27,MMM	1
30	PAOZZ	5310009359021	96906	MS51943-35	NUT,SELF-LOCKING,HE 3/8-16..... UOC:A11,A24,A27,B24,H11,H24,H27,MMM	8
31	PFOZZ	5340011993495	19207	12339798	BRACKET,SPECIAL..... UOC:A11,A24,A27,B24,H11,H24,H27,MMM	1
32	PAOZZ	5310000614650	96906	MS51943-31	NUT,SELF-LOCKING,HE 1/4-20..... UOC:A11,A24,A27,B24,H11,H24,H27,MMM	2
33	PAOZZ	5310011023270	24617	2436161	WASHER,FLAT 1/4..... UOC:A11,A24,A27,B24,H11,H24,H27,MMM	4
34	PFOZZ	5340012520741	19207	12339759	BRACKET,T..... UOC:A11,A24,A27,B24,H11,H24,H27,MMM	1
35	PAOZZ	5320012645978	19207	12339355-2	RIVET,BLIND 3/16 DIA. .214-.437 GRIP..... UOC:A11,A24,A27,B24,H11,H24,H27,MMM	2
36	PAOZZ	5320012716357	9K475	MGLP-B6-4	RIVET,BLIND 3/16..... UOC:A11,A24,A27,B24,H11,H24,H27,MMM	5
37	PAOZZ	5305000712505	80204	B1821BH025C088N	SCREW,CAP,HEXAGON H 1/4-20 X 7/8... UOC:A11,A24,A27,B24,H11,H24,H27,MMM	2
38	PAOOO	2590011885080	19207	12339679-2	PEDESTAL ASSEMBLY,T..... UOC:A11,A24,A27,B24,H11,H24,H27,MMM	1
39	XAOZZ		34623	5579386	.PEDESTAL..... UOC:A11,A24,A27,B24,H11,H24,H27,MMM	1
40	PAOZZ	5315012181114	34623	G45637	.PIN,SPRING 1/4 X 5/8..... UOC:A11,A24,A27,B24,H11,H24,H27,NNN	1

END OF FIGURE



5 — 6  
thru  
9

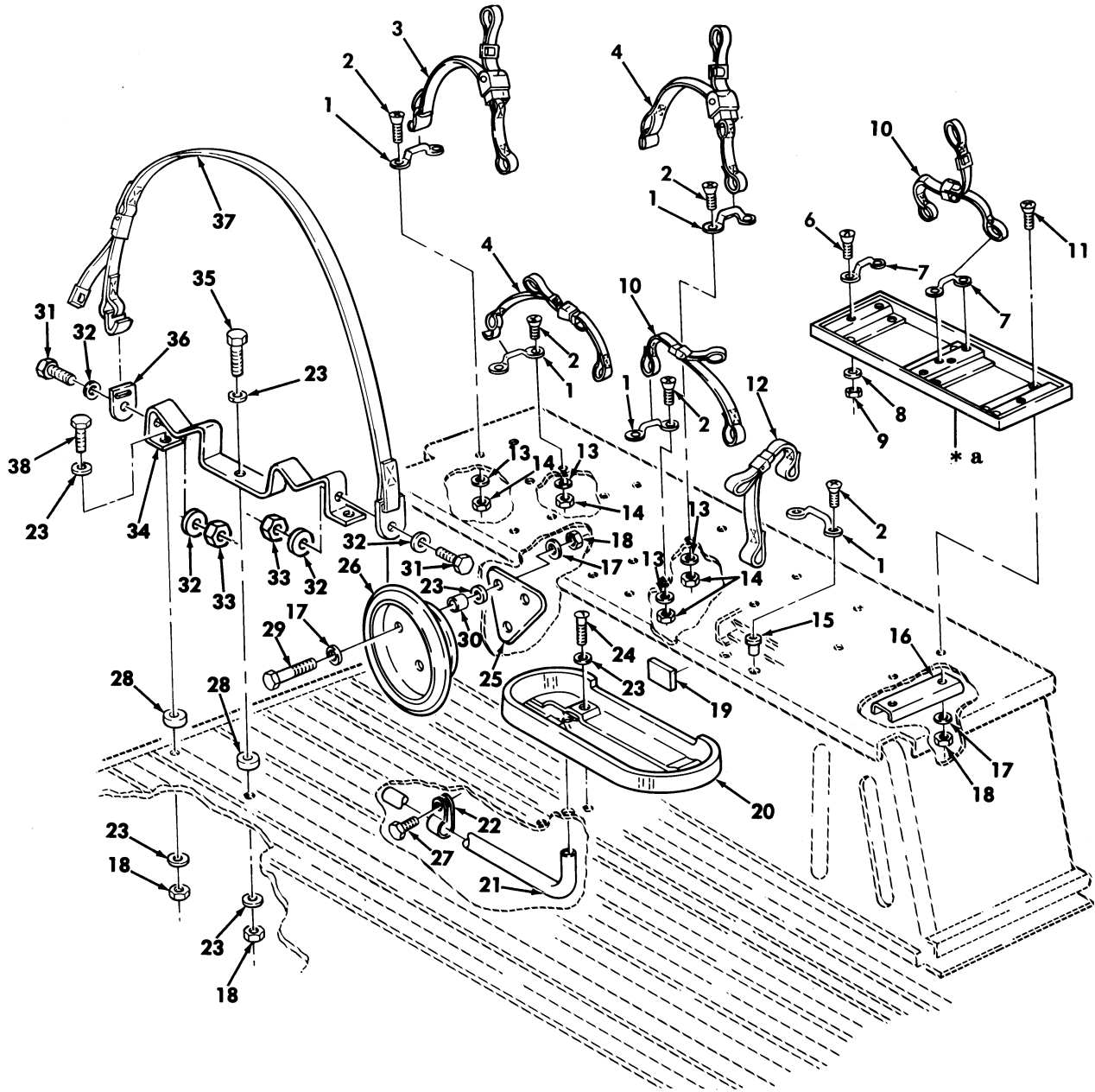

\* a PART OF ITEM 5

Figure 246. TOW Tripod, Fuel Can, M16 Ammo Stowage Brackets, Telephone Cable Reel, Combat Ration Straps, and Mounting Components.

SECTION II			TM9-2320-280-24P			
(1)	(2)	(3)	(4)	(5)	(6)	(7)
ITEM NO	SMR CODE	NSN	CAGEC	PART NUMBER	DESCRIPTION AND USABLE ON CODES(UCO)	QTY
					GROUP 1808 STOWAGE RACKS,BOXES, STRAPS,CARRYING CASES,CABLE REELS, HOSE REELS	
					FIG. 246 TOW TRIPOD,FUEL CAN,M16 AMMO STOWAGE BRACKETS,TELEPHONE CABLE REEL,COMBAT RATION STRAPS,AND MOUNTING COMPONENTS	
1	PAOZZ	5340004895684	19220	6411-B	LOOP,STRAP FASTENER.....	9
					UCO:A11,A24,A27,B24,H11,H24,H27,MMM	
2	PAOZZ	5305009931848	96906	MS35207-265	SCREW,MACHINE #10-32 X 3/4.....	18
					UCO:A11,A24,A27,B24,H11,H24,H27,MMM	
3	PAOZZ	5340011991663	31272	45096-11	STRAP,WEBBING.....	1
					UCO:A11,A24,A27,B24,H11,H24,H27,MMM	
4	PAOZZ	5340011985165	31272	45096-10	STRAP,WEBBING.....	2
					UCO:A11,A24,A27,B24,H11,H24,H27,MMM	
5	PAOOO	2590011887384	19207	12340174	RACK,AMMUNITION STO.....	1
					UCO:A11,A24,A27,B24,H11,H24,H27,MMM	
6	PAOZZ	5305011850114	7X677	157166	.SCREW #10-32 X 3/4.....	8
					UCO:A11,A24,A27,B24,H11,H24,H27,MMM	
7	PAOZZ	5340004895684	19220	6411-B	.LOOP,STRAP FASTENER.....	4
					UCO:A11,A24,A27,B24,H11,H24,H27,MMM	
8	PAOZZ	5310000145850	96906	MS27183-42	.WASHER,FLAT #10.....	8
					UCO:A11,A24,A27,B24,H11,H24,H27,MMM	
9	PAOZZ	5310012520481	34623	5593048	.NUT,SELF-LOCKING,HE #10-32.....	8
					UCO:A11,A24,A27,B24,H11,H24,H27,MMM	
10	PAOZZ	5340011982255	31272	44647-12	STRAP,WEBBING.....	3
					UCO:A11,A24,A27,B24,H11,H24,H27,MMM	
11	PAOZZ	5305007195017	96906	MS51959-82	SCREW,MACHINE 1/4-20 X 7/8.....	6
					UCO:A11,A24,A27,B24,H11,H24,H27,MMM	
12	PAOZZ	5340012586157	31272	45606-11	STRAP,WEBBING.....	1
					UCO:A11,A24,A27,B24,H11,H24,H27,MMM	
13	PAOZZ	5310000145850	96906	MS27183-42	WASHER,FLAT #10.....	18
					UCO:A11,A24,A27,B24,H11,H24,H27,MMM	
14	PAOZZ	5310012520481	34623	5593048	NUT,SELF-LOCKING,HE #10-32.....	16
					UCO:A11,A24,A27,B24,H11,H24,H27,MMM	
15	PAOZZ	5310011981723	19207	12339998-14	NUT,PLAIN,BLIND RIV #10-32.....	2
					UCO:A11,A24,A27,B24,H11,H24,H27,MMM	
16	PFOZZ	5340011982249	19207	12340129	STRAP,RETAINING.....	2
					UCO:A11,A24,A27,B24,H11,H24,H27,MMM	
17	PAOZZ	5310011023270	24617	2436161	WASHER,FLAT 1/4.....	12
					UCO:A11,A24,A27,B24,H11,H24,H27,MMM	
18	PAOZZ	5310000614650	96906	MS51943-31	NUT,SELF-LOCKING,HE 1/4-20.....	12
					UCO:A11,A24,A27,B24,H11,H24,H27,MMM	
19	PAOZZ	5340012535479	19207	12340130	STRAP,RETAINING.....	1
					UCO:A11,A24,A27,B24,H11,H24,H27,MMM	
20	PFOZZ	2510011978572	19207	12340155	TRAY,FUEL CAN.....	1
					UCO:A11,A24,A27,B24,H11,H24,H27,MMM	
21	MOOZZ		34623	5578887	HOSE MAKE FROM HOSE, P/N 9440949, 11 INCHES LONG.....	1
					UCO:A11,A24,A27,B24,H11,H24,H27,MMM	
22	PAOZZ	5340002827537	96906	MS21333-41	CLAMP,LOOP.....	1

SECTION II			TM9-2320-280-24P			
(1)	(2)	(3)	(4)	(5)	(6)	(7)
ITEM NO	SMR CODE	NSN	CAGEC	PART NUMBER	DESCRIPTION AND USABLE ON CODES(UOC)	QTY
23	PAOZZ	5310008094058	96906	MS27183-10	UOC:A11,A24,A27,B24,H11,H24,H27,MMM WASHER,FLAT 1/4.....	8
24	PAOZZ	5305000711318	96906	MS51957-83	UOC:A11,A24,A27,B24,H11,H24,H27,MMM SCREW,MACHINE 1/4-20 X 1.00.....	4
25	PFOZZ	5365012116083	34623	5579811	UOC:A11,A24,A27,B24,H11,H24,H27,MMM SPACER,PLATE.....	1
26	PFOZZ	5340011967733	19207	12339753	UOC:A11,A24,A27,B24,H11,H24,H27,MMM BRACKET,MOUNTING.....	1
27	PAOZZ	5305012552675	34623	5592970	UOC:A11,A24,A27,B24,H11,H24,H27,MMM SCREW,TAPPING 1/4-14 X 5/8.....	1
28	PAOZZ	5365012564526	19207	12339814-6	UOC:A11,A24,A27,B24,H11,H24,H27,MMM SPACER,SLEEVE.....	2
29	PAOZZ	5305000712510	80204	B1821BH025C175N	UOC:A11,A24,A27,B24,H11,H24,H27,MMM SCREW,CAP,HEXAGON H 1/4-20 X 1.75..	3
30	PFOZZ	5365012140006	19207	12339814-2	UOC:A11,A24,A27,B24,H11,H24,H27,MMM SPACER,SLEEVE.....	3
31	PAOZZ	5305000711322	96906	MS51960-65	UOC:A11,A24,A27,B24,H11,H24,H27,MMM SCREW,MACHINE #10-24 X 1.00.....	2
32	PAOZZ	5310012349416	96906	MS51412-2	UOC:A11,A24,A27,B24,H11,H24,H27,MMM WASHER,FLAT #10.....	4
33	PAOZZ	5310009349764	96906	MS35649-205	UOC:A11,A24,A27,B24,H11,H24,H27,MMM NUT,PLAIN,HEXAGON #10-24.....	2
34	PFOZZ	5340012468290	19207	12339754	UOC:A11,A24,A27,B24,H11,H24,H27,MMM BRACKET,MOUNTING.....	1
35	PAOZZ	5305000712509	80204	B1821BH025C150N	UOC:A11,A24,A27,B24,H11,H24,H27,MMM SCREW,CAP,HEXAGON H 1/4-20 X 1.50..	3
35	PAOZZ	5305000712509	80204	B1821BH025C150N	UOC:A11,A24,A27,H11,H24,H27,MMM SCREW,CAP,HEXAGON H 1/4-20 X 1.50..	2
36	PFOZZ	5340012564657	34623	5594703	UOC:B24 LOOP,STRAP FASTENER.....	1
37	PAOZZ	5340012593956	34623	45302-11	UOC:A11,A24,A27,H11,H24,H27,MMM STRAP,WEBBING.....	1
38	PAOZZ	5305000712510	80204	B1821BH025C175N	UOC:A11,A24,A27,B24,H11,H24,H27,MMM SCREW,CAP,HEXAGON H.....	1
					UOC:B24	

END OF FIGURE

4  
5  
thru  
16

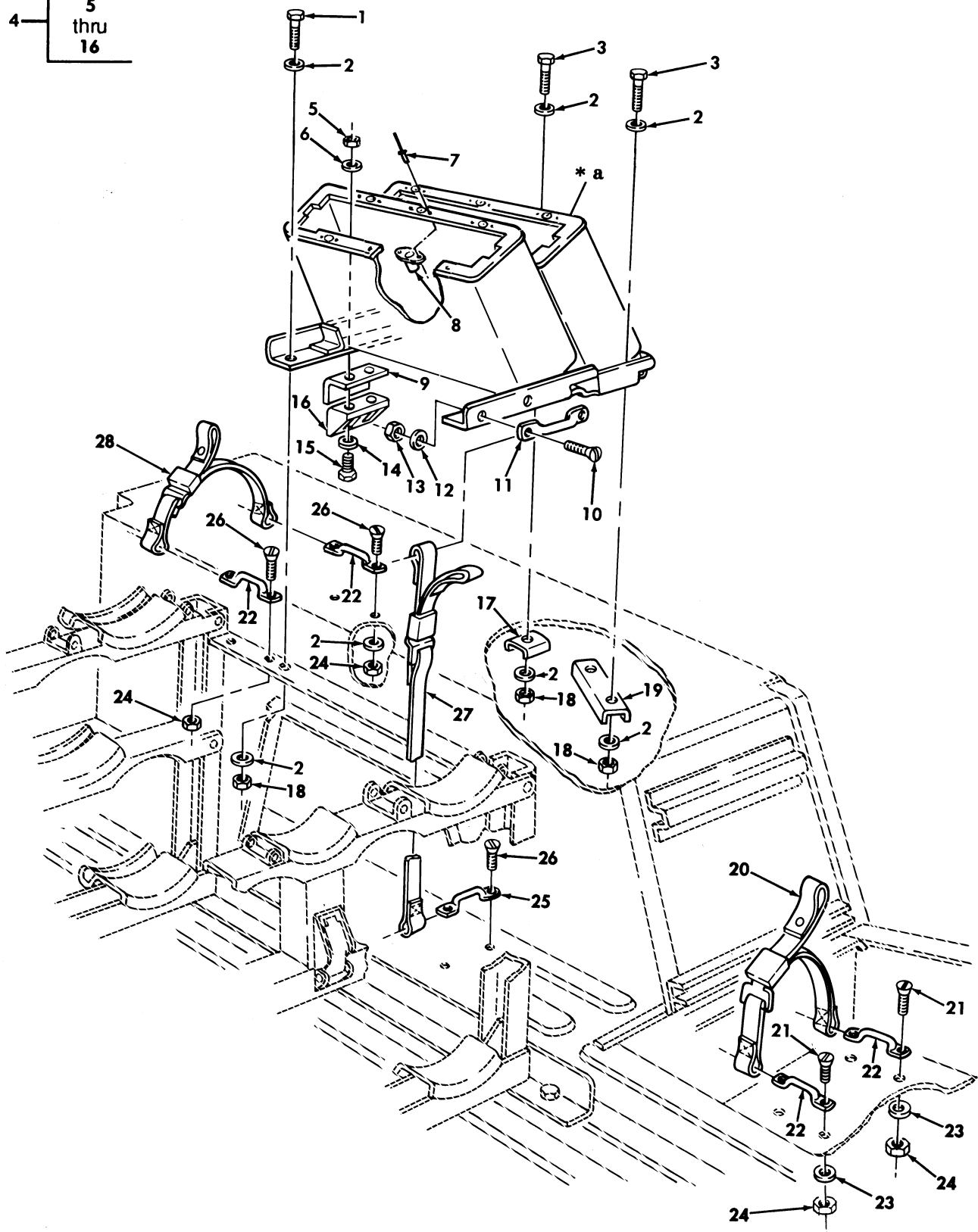

\* a PART OF ITEM 4

Figure 247. MGS Battery Stowage Rack and Related Parts.

SECTION II			TM9-2320-280-24P			
(1)	(2)	(3)	(4)	(5)	(6)	(7)
ITEM	SMR			PART		
NO	CODE	NSN	CAGEC	NUMBER	DESCRIPTION AND USABLE ON CODES(UCO)	QTY
					GROUP 1808 STOWAGE RACKS,BOXES, STRAPS,CARRING CASES,CABLE REELS, HOSE REELS	
					FIG. 247 MGS BATTERY STOWAGE RACK AND RELATED PARTS	
1	PAOZZ	5305002253843	80204	B1821BH025C100N	SCREW,CAP,HEXAGON H 1/4-20 X 1.00..	2
					UCO:A11,A24,A27,B24,H11,H24,H27,MMM	
2	PAOZZ	5310011023270	24617	2436161	WASHER,FLAT 1/4.....	16
					UCO:A11,A24,A27,B24,H11,H24,H27,MMM	
3	PAOZZ	5305009585246	80205	MS35190-289	SCREW,MACHINE 1/4-20 X 3/4.....	6
					UCO:A11,A24,A27,B24,H11,H24,H27,MMM	
4	PAOOO	6140011885113	19207	12339750	RACK,BATTERY.....	1
					UCO:A11,A24,A27,B24,H11,H24,H27,MMM	
5	PAOZZ	5310000614650	96906	MS51943-31	.NUT,SELF-LOCKING,HE 1/4-20.....	2
					UCO:A11,A24,A27,B24,H11,H24,H27,MMM	
6	PAOZZ	5310008093078	96906	MS27183-11	.WASHER,FLAT 1/4.....	2
					UCO:A11,A24,A27,B24,H11,H24,H27,MMM	
7	PAOZZ	5320013626195	11815	AAC-32	.RIVET,BLIND.....	24
					UCO:A11,A24,A27,B24,H11,H24,H27,MMM	
8	PAOZZ	5325008861067	18876	10224818	.FASTENER,RECEPTACLE.....	12
					UCO:A11,A24,A27,B24,H11,H24,H27,MMM	
9	PAOZZ	5340012832458	34623	5583556-B	.BRACKET,ANGLE.....	1
					UCO:A11,A24,A27,B24,H11,H24,H27,MMM	
10	PAOZZ	5305009953444	96906	MS35207-266	.SCREW,MACHINE #10-32 X 7/8.....	4
					UCO:A11,A24,A27,B24,H11,H24,H27,MMM	
11	PAOZZ	5340004895684	19220	6411-B	.LOOP,STRAP FASTENER.....	2
					UCO:A11,A24,A27,B24,H11,H24,H27,MMM	
12	PAOZZ	5310000145850	96906	MS27183-42	.WASHER,FLAT #10.....	4
					UCO:A11,A24,A27,B24,H11,H24,H27,MMM	
13	PAOZZ	5310012520481	34623	5593048	.NUT,SELF-LOCKING,HE #10-32.....	4
					UCO:A11,A24,A27,B24,H11,H24,H27,MMM	
14	PAOZZ	5310011023270	24617	2436161	.WASHER,FLAT 1/4.....	2
					UCO:A11,A24,A27,B24,H11,H24,H27,MMM	
15	PAOZZ	5305000712505	80204	B1821BH025C088N	.SCREW,CAP,HEXAGON H 1/4-20 X 7/8..	2
					UCO:A11,A24,A27,B24,H11,H24,H27,MMM	
16	PAOZZ	5340012597523	34623	5583555	.BUMPER,NONMETALLIC.....	1
					UCO:A11,A24,A27,B24,H11,H24,H27,MMM	
17	PFOZZ	5340011982248	34623	5582423	STRAP,RETAINING.....	3
					UCO:A11,A24,A27,B24,H11,H24,H27,MMM	
18	PAOZZ	5310000614650	96906	MS51943-31	NUT,SELF-LOCKING,HE 1/4-20.....	8
					UCO:A11,A24,A27,B24,H11,H24,H27,MMM	
19	PFOZZ	5340011998258	19207	12339758	STRAP,RETAINING.....	1
					UCO:A11,A24,A27,B24,H11,H24,H27,MMM	
20	PAOZZ	5340011982255	31272	44647-12	STRAP,WEBBING.....	1
					UCO:A11,A24,A27,B24,H11,H24,H27,MMM	
21	PAOZZ	5305012551016	34623	5592884	SCREW,MACHINE #10-32 X 3/4.....	4
					UCO:A11,A24,A27,B24,H11,H24,H27,MMM	
22	PAOZZ	5340004895684	19220	6411-B	LOOP,STRAP FASTENER.....	4
					UCO:A11,A24,A27,B24,H11,H24,H27,MMM	
23	PAOZZ	5310012349416	96906	MS51412-2	WASHER,FLAT #10-32.....	4
					UCO:A11,A24,A27,B24,H11,H24,H27,MMM	

SECTION II			TM9-2320-280-24P			
(1)	(2)	(3)	(4)	(5)	(6)	(7)
ITEM	SMR			PART		
NO	CODE	NSN	CAGEC	NUMBER	DESCRIPTION AND USABLE ON CODES(UC)	QTY
24	PAOZZ	5310012520481	34623	5593048	NUT, SELF-LOCKING, HE #10-32.....	8
					UOC:A11, A24, A27, B24, H11, H24, H27, MMM	
25	PAOZZ	5340012141778	34623	12338839-7	STRAP, RETAINING.....	1
					UOC:A11, A24, A27, B24, H11, H24, H27, MMM	
26	PAOZZ	5305012551016	34623	5592884	SCREW, MACHINE #10-32 X 5/8.....	6
					UOC:A11, A24, A27, B24, H11, H24, H27, MMM	
27	PAOZZ	5340012034646	31272	44648-15	STRAP, WEBBING.....	1
					UOC:A11, A24, A27, B24, H11, H24, H27, MMM	
28	PAOZZ	5340012032708	31272	44648-17	STRAP, WEBBING.....	1
					UOC:A11, A24, A27, B24, H11, H24, H27, MMM	

END OF FIGURE

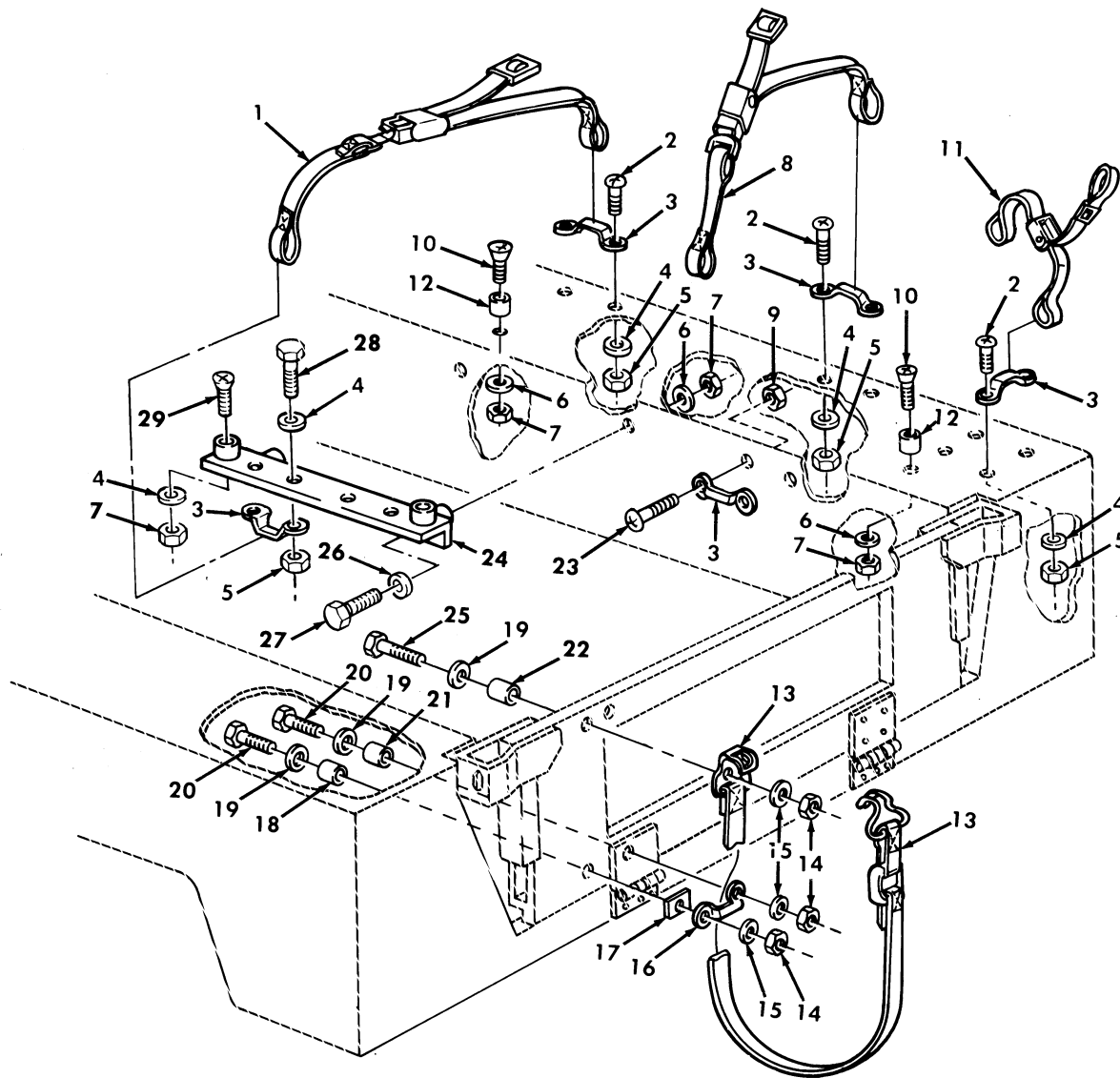

Figure 248. Night Sight, Bore Sight Collimator, and Camouflage Pack Stowage.

SECTION II			TM9-2320-280-24P			
(1)	(2)	(3)	(4)	(5)	(6)	(7)
ITEM NO	SMR CODE	NSN	CAGEC	PART NUMBER	DESCRIPTION AND USABLE ON CODES(UCO)	QTY
					GROUP 1808 STOWAGE RACKS,BOXES, STRAPS,CARRYING CASES,CABLE REELS, HOSE REELS	
					FIG. 248 NIGHT SIGHT,BORE SIGHT COLLIMATOR,AND CAMOUFLAGE PACK STOWAGE	
1	PAOZZ	5340012036539	31272	44648-13	STRAP,WEBBING.....	2
					UCO:A11,A24,A27,B24,H11,H24,H27,MMM	
2	PAOZZ	5305012542452	34623	5593286	SCREW,MACHINE #10-24 X 1.00.....	12
					UCO:A11,A24,A27,B24,H11,H24,H27,MMM	
3	PAOZZ	5340004895684	19220	6411-B	LOOP,STRAP FASTENER.....	10
					UCO:A11,A24,A27,B24,H11,H24,H27,MMM	
4	PAOZZ	5310000145850	96906	MS27183-42	WASHER,FLAT #10.....	16
					UCO:A11,A24,A27,B24,H11,H24,H27,MMM	
5	PAOZZ	5310002081918	88044	AN365-1024A	NUT,SELF-LOCKING,HE #10-24.....	16
					UCO:A11,A24,A27,B24,H11,H24,H27,MMM	
6	PAOZZ	5310011023270	24617	2436161	WASHER,FLAT 1/4.....	8
					UCO:A11,A24,A27,B24,H11,H24,H27,MMM	
7	PAOZZ	5310000614650	96906	MS51943-31	NUT,SELF-LOCKING,HE 1/4-20.....	8
					UCO:A11,A24,A27,B24,H11,H24,H27,MMM	
8	PAOZZ	5340012032707	31272	44648-14	STRAP,WEBBING.....	2
					UCO:A11,A24,A27,B24,H11,H24,H27,MMM	
9	PAOZZ	5310012520481	34623	5593048	NUT,SELF-LOCKING,HE #10-32.....	4
					UCO:A11,A24,A27,B24,H11,H24,H27,MMM	
10	PAOZZ	5305009889106	96906	MS35191-292	SCREW,MACHINE 1/4-20 X 7/8.....	4
					UCO:A11,A24,A27,B24,H11,H24,H27,MMM	
11	PAOZZ	5340011982255	31272	44647-12	STRAP,WEBBING.....	1
					UCO:A11,A24,A27,B24,H11,H24,H27,MMM	
12	PAOZZ	5365011983399	34623	5583558	SPACER,SLEEVE.....	4
					UCO:A11,A24,A27,B24,H11,H24,H27,MMM	
13	PAOZZ	5340011983457	31272	44943-11	STRAP,WEBBING.....	4
					UCO:A11,A24,A27,B24,H11,H24,H27,MMM	
14	PAOZZ	5310012552695	34623	5593035	NUT,SELF-LOCKING,HE 1/4-20.....	16
					UCO:A11,A24,A27,B24,H11,H14,H27,MMM	
15	PAOZZ	5310012538949	34623	5592926	WASHER,FLAT 1/4.....	16
					UCO:A11,A24,A27,B24,H11,H24,H27,MMM	
16	PAOZZ	5340011978674	34623	5583568	HANDLE,BOW.....	4
					UCO:A11,A24,A25,A26,A27,B17,B18,B24, B25,C17,H11,H17,H18,H24,H25,H26,H27, MMM	
17	PAOZZ	5365011983463	19207	12340132	SPACER,PLATE.....	2
					UCO:A11,A24,A25,A26,A27,B17,B18,B24, B25,C17,H11,H17,H18,H24,H25,H26,H27, MMM	
18	PFOZZ	5365011983401	34623	5583572	SPACER,SLEEVE.....	6
					UCO:A11,A24,A25,A26,A27,B17,B18,B24, B25,C17,H11,H17,H18,H24,H25,H26,H27, MMM	
19	PAOZZ	5310008093078	96906	MS27183-11	WASHER,FLAT 1/4.....	16
					UCO:A11,A24,A25,A26,A27,B17,B18,B24, B25,C17,H11,H17,H18,H24,H25,H26,H27,	



SECTION II			TM9-2320-280-24P			
(1)	(2)	(3)	(4)	(5)	(6)	(7)
ITEM NO	SMR CODE	NSN	CAGEC	PART NUMBER	DESCRIPTION AND USABLE ON CODES(UC)	QTY
20	PAOZZ	5305000712512	80204	B1821BH025C225N	MMM SCREW,CAP,HEXAGON H 1/4-20 X 2.25.. UOC:A11,A24,A25,A26,A27,B17,B18,B24, B25,C17,H11,H17,H18,H24,H25,H26,H27, MMM	8
21	PFOZZ	5365011983400	34623	5584134	SPACER,SLEEVE..... UOC:A11,A24,A25,A26,A27,B17,B18,B24, B25,C17,H11,H17,H18,H24,H25,H26,H27, MMM	2
22	PAOZZ	5365011983505	34623	5583571	SPACER,SLEEVE..... UOC:A11,A24,A27,B24,H11,H24,H27,MMM	8
23	PAOZZ	5305012551016	34623	5592884	SCREW,MACHINE #10-32 X 5/8..... UOC:A11,A24,A27,B24,H11,H24,H27,MMM	4
24	PFOZZ	2590011997977	19207	12339809	SUPPORT,NIGHT-SIGHT..... UOC:A11,A24,A27,B24,H11,H24,H27,MMM	1
25	PAOZZ	5305000712513	80204	B1821BH025C250N	SCREW,CAP,HEXAGON H 1/4-20 X 2.50.. UOC:A11,A24,A27,B24,H11,H24,H27,MMM	8
26	PAOZZ	5310008094058	96906	MS27183-10	WASHER,FLAT 1/4..... UOC:A11,A24,A27,B24,H11,H24,H27,MMM	2
27	PAOZZ	5305000712509	80204	B1821BH025C150N	SCREW,CAP,HEXAGON H 1/4-20 X 1.50.. UOC:A11,A24,A27,B24,H11,H24,H27,MMM	2
28	PAOZZ	5305002400194	96906	MS51849-76	SCREW,MACHINE #10-24 X 3/4..... UOC:A11,A24,A27,B24,H11,H24,H27,MMM	4
29	PAOZZ	5305007195003	96906	MS51959-84	SCREW,MACHINE 1/4-20 X 1.25..... UOC:A11,A24,A27,B24,H11,H24,H27,MMM	2

END OF FIGURE

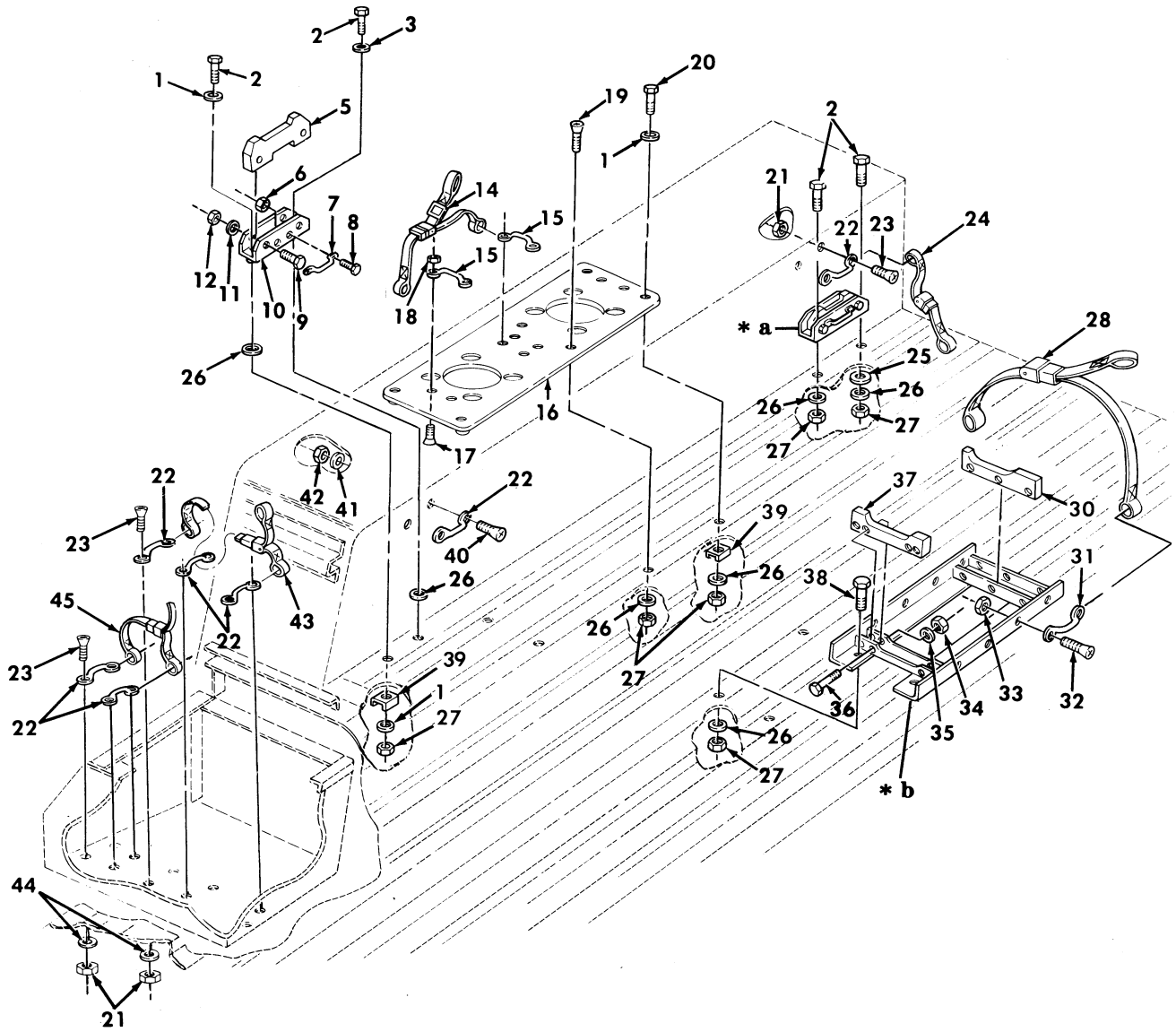
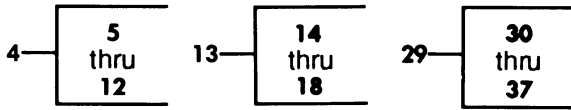

- \* a PART OF ITEM 4
- \* b PART OF ITEM 29

Figure 249. TOW Night Sight Batteries and Coolant, Radiac Meter, Night Vision Goggles Stowage, and TAS Carry Bag Stowage (Sheet 1 of 2).

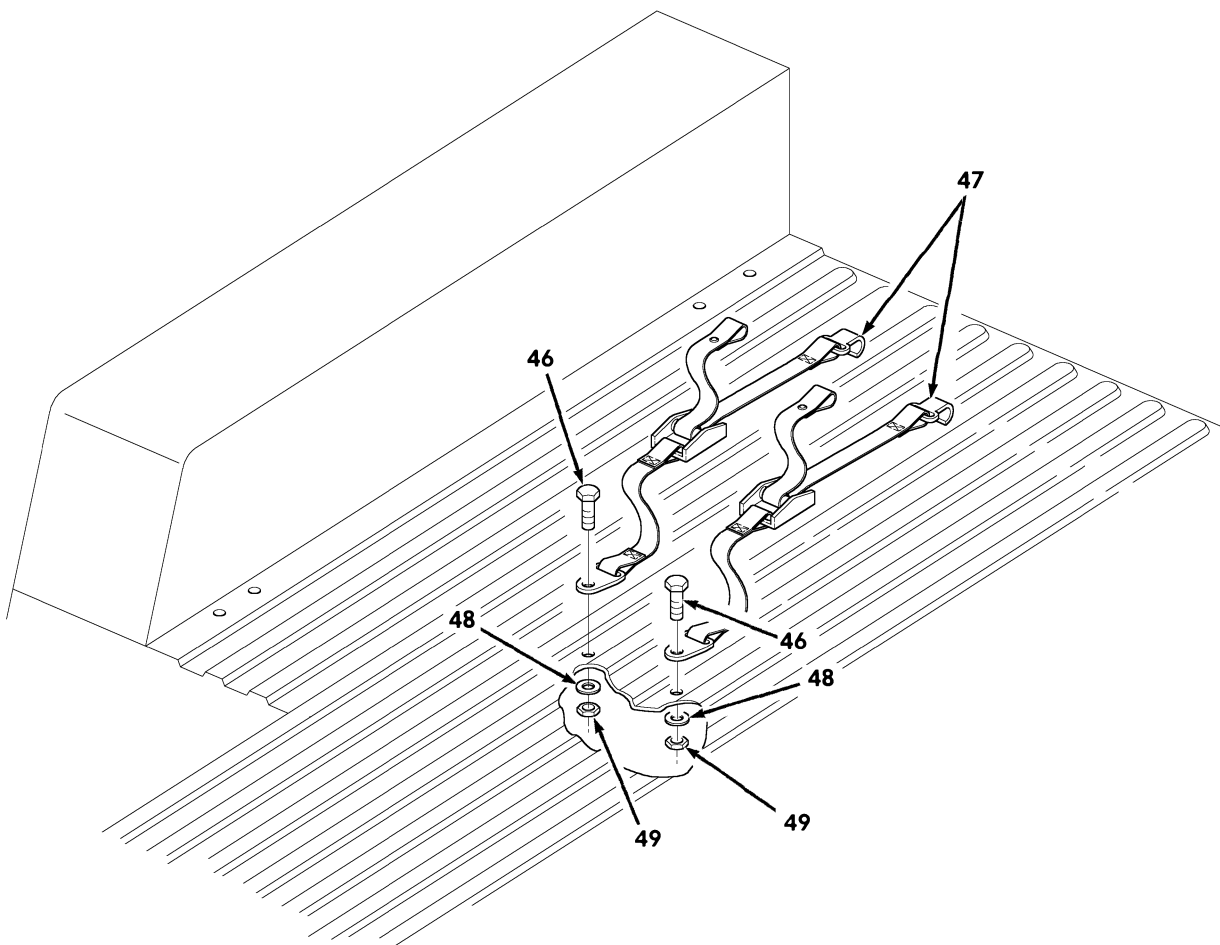

Figure 249. TOW Night Sight Batteries and Coolant, Radiac Meter, Night Vision Goggles Stowage, and TAS Carry Bag Stowage (Sheet 2 of 2).

SECTION II			TM9-2320-280-24P			
(1)	(2)	(3)	(4)	(5)	(6)	(7)
ITEM	SMR			PART		
NO	CODE	NSN	CAGEC	NUMBER	DESCRIPTION AND USABLE ON CODES(UOC)	QTY
					GROUP 1808 STOWAGE RACKS,BOXES, STRAPS,CARRYING CASES,CABLE REELS, HOSE REELS	
					FIG. 249 TOW NIGHT SIGHT BATTERIES AND COOLANT,RADIAC METER,NIGHT VISION GOGGLES STOWAGE,AND TAS CARRING BAG STOWAGE	
1	PAOZZ	5310008094058	96906	MS27183-10	WASHER,FLAT 1/4.....	6
					UOC:A11,A24,A27,B24,H11,H24,H27	
2	PAOZZ	5305002253843	80204	B1821BH025C100N	SCREW,CAP,HEXAGON H 1/4-20 X 1.00..	4
					UOC:A11,A24,A27,B24,H11,H24,H27	
3	PAOZZ	5310002748715	96906	MS35338-63	WASHER,LOCK 1/4.....	1
					UOC:A11,A24,A27,B24,H11,H24,H27	
4	PFOOO	5340011887383	19207	12339813	BRACKET,MOUNTING.....	2
					UOC:A11,A24,A27,B24,H11,H24,H27	
5	PFOZZ	2590011946981	19207	12339811	.PAD,CUSHIONING.....	1
					UOC:A11,A24,A27,B24,H11,H24,H27	
6	PAOZZ	5310012520481	34623	5593048	.NUT,SELF-LOCKING,HE #10-32.....	2
					UOC:A11,A24,A27,B24,H11,H24,H27	
7	PAOZZ	5340004895684	19220	6411-B	.LOOP,STRAP FASTENER.....	1
					UOC:A11,A24,A27,B24,H11,H24,H27	
8	PAOZZ	5305012551016	34623	5592884	.SCREW,MACHINE #10-32 X 5/8.....	2
					UOC:A11,A24,A27,B24,H11,H24,H27	
9	PAOZZ	5305000712510	80204	B1821BH025C175N	.SCREW,CAP,HEXAGON H 1/4-20 X 1.75.	2
					UOC:A11,A24,A27,B24,H11,H24,H27	
10	XAOZZ		34623	5582902	.CHANNEL ASSEMBLY.....	1
					UOC:A11,A24,A27,B24,H11,H24,H27	
11	PAOZZ	5310011023270	24617	2436161	.WASHER,FLAT 1/4.....	2
					UOC:A11,A24,A27,B24,H11,H24,H27	
12	PAOZZ	5310012552695	34623	5593035	.NUT,SELF-LOCKING,HE 1/4-20.....	2
					UOC:A11,A24,A27,B24,H11,H24,H27	
13	PFOOO	2590012468291	19207	12339818	BRACKET ASSEMBLY,NI.....	1
					UOC:A11,A24,A27,B24,H11,H24,H27	
14	PAOZZ	5340011982255	31272	44647-12	.STRAP,WEBBING.....	2
					UOC:A11,A24,A27,B24,H11,H24,H27	
15	PAOZZ	5340004895684	19220	6411-B	.LOOP,STRAP FASTENER.....	4
					UOC:A11,A24,A27,B24,H11,H24,H27	
16	XAOZZ		34623	5593985	.BASE ASSEMBLY.....	1
					UOC:A11,A24,A27,B24,H11,H24,H27	
17	PAOZZ	5305009585471	96906	MS35190-273	.SCREW,MACHINE #10-24 X 3/4.....	8
					UOC:A11,A24,A27,B24,H11,H24,H27	
18	PAOZZ	5310002081918	88044	AN365-1024A	.NUT,SELF-LOCKING,HE #10-24.....	8
					UOC:A11,A24,A27,B24,H11,H24,H27	
19	PAOZZ	5305012551017	34623	5592846	SCREW,MACHINE 1/4-20 X 1.50.....	2
					UOC:A11,A24,A27,B24,H11,H24,H27	
20	PAOZZ	5305000712509	80204	B1821BH025C150N	SCREW,CAP,HEXAGON H 1/4-20 X 1.50..	4
					UOC:A11,A24,A27,B24,H11,H24,H27	
21	PAOZZ	5310012520481	34623	5593048	NUT,SELF-LOCKING,HE #10-32.....	12
					UOC:A11,A24,A27,B24,H11,H24,H27	
22	PAOZZ	5340004895684	19220	6411-B	LOOP,STRAP FASTENER.....	7

SECTION II			TM9-2320-280-24P			
(1)	(2)	(3)	(4)	(5)	(6)	(7)
ITEM	SMR			PART		
NO	CODE	NSN	CAGEC	NUMBER	DESCRIPTION AND USABLE ON CODES(UOC)	QTY
23	PAOZZ	5305012510728	34623	5592823	UOC:A11,A24,A27,B24,H11,H24,H27 SCREW,MACHINE.....	12
24	PAOZZ	5340011982254	31272	44648-20	UOC:A11,A24,A27,B24,H11,H24,H27 STRAP,WEBBING.....	2
25	PAOZZ	5310012520513	34623	5592916	UOC:A11,A24,A27,B24,H11,H24,H27 WASHER,FLAT 1/4.....	1
26	PAOZZ	5310011023270	24617	2436161	UOC:A11,A24,A27,B24,H11,H24,H27 WASHER,FLAT 1/4.....	13
27	PAOZZ	5310000614650	96906	MS51943-31	UOC:A11,A24,A27,B24,H11,H24,H27 NUT,SELF-LOCKING,HE 1/4-20.....	13
28	PAOZZ	5340012036538	31272	44648-19	UOC:A11,A24,A27,B24,H11,H24,H27 STRAP,WEBBING.....	2
29	PFOOO	5340011887382	19207	12339805	UOC:A11,A24,A27,B24,H11,H24,H27 BRACKET,MOUNTING.....	1
30	PFOZZ	2590011946980	19207	12339803	UOC:A11,A24,A27,B24,H11,H24,H27 .PAD,CUSHIONING.....	1
31	PAOZZ	5340004895684	19220	6411-B	UOC:A11,A24,A27,B24,H11,H24,H27 .LOOP,STRAP FASTENER.....	4
32	PAOZZ	5305012551016	34623	5592884	UOC:A11,A24,A27,B24,H11,H24,H27 .SCREW,MACHINE #10-32 X 5/8.....	8
33	PAOZZ	5310012520481	34623	5593048	UOC:A11,A24,A27,B24,H11,H24,H27 .NUT,SELF-LOCKING,HE #10-32.....	8
34	PAOZZ	5310012552695	34623	5593035	UOC:A11,A24,A27,B24,H11,H24,H27 .NUT,SELF-LOCKING,HE 1/4-20.....	7
35	PAOZZ	5310011023270	24617	2436161	UOC:A11,A24,A27,B24,H11,H14,H27 .WASHER,FLAT 1/4.....	7
36	PAOZZ	5305000712513	80204	B1821BH025C250N	UOC:A11,A24,A27,B24,H11,H24,H27 .SCREW,CAP,HEXAGON H 1/4-20 X 2.50..	7
37	PFOZZ	2590011946979	19207	12339802	UOC:A11,A24,A27,B24,H11,H24,H27 .PAD,CUSHIONING.....	1
38	PAOZZ	5305000680509	80204	B1821BH025C125N	UOC:A11,A24,A27,B24,H11,H24,H27 SCREW,CAP,HEXAGON H 1/4-20 X 1.25..	4
39	PFOZZ	5340011982248	34623	5582423	UOC:A11,A24,A27,B24,H11,H24,H27 STRAP,RETAINING.....	3
40	PAOZZ	5305012542451	34623	5592862	UOC:A11,A24,A27,B24,H11,H24,H27 SCREW,MACHINE #10-24 X 3/4.....	2
41	PAOZZ	5310000145850	96906	MS27183-42	UOC:A11,A24,A27,B24,H11,H24,H27 WASHER,FLAT.....	2
42	PAOZZ	5310002081918	88044	AN365-1024A	UOC:A11,A24,A27,B24,H11,H24,H27 NUT,SELF-LOCKING,HE #10-24.....	2
43	PAOZZ	5340011982256	31272	44648-22	UOC:A11,A24,A27,B24,H11,H24,H27 STRAP,WEBBING.....	1
44	PAOZZ	5310012349416	96906	MS51412-2	UOC:A11,A24,A27,B24,H11,H24,H27 WASHER,FLAT #10.....	10
45	PAOZZ	5340011982257	31272	44648-21	UOC:A11,A24,A27,B24,H11,H24,H27 STRAP,WEBBING.....	1
46	PAOZZ	5305000680509	80204	B1821BH025C125N	UOC:A11,A24,A27,B24,H11,H24,H27 SCREW,CAP,HEXAGON H 1/4-20 X 1.25..	2
47	PAOZZ	5340014671669	19207	12340595-2	UOC:MMM STRAP ASSEMBLY.....	2
48	PAOZZ	5310011023170	24617	2436161	UOC:MMM WASHER,FLAT 1/4.....	2

SECTION II			TM9-2320-280-24P			
(1)	(2)	(3)	(4)	(5)	(6)	(7)
ITEM	SMR			PART		
NO	CODE	NSN	CAGEC	NUMBER	DESCRIPTION AND USABLE ON CODES(UC)	QTY
49	PAOZZ	5310000614650	96906	MS51943-31	NUT, SELF-LOCKING, HE 1/4-20..... UC:MMM	2

END OF FIGURE

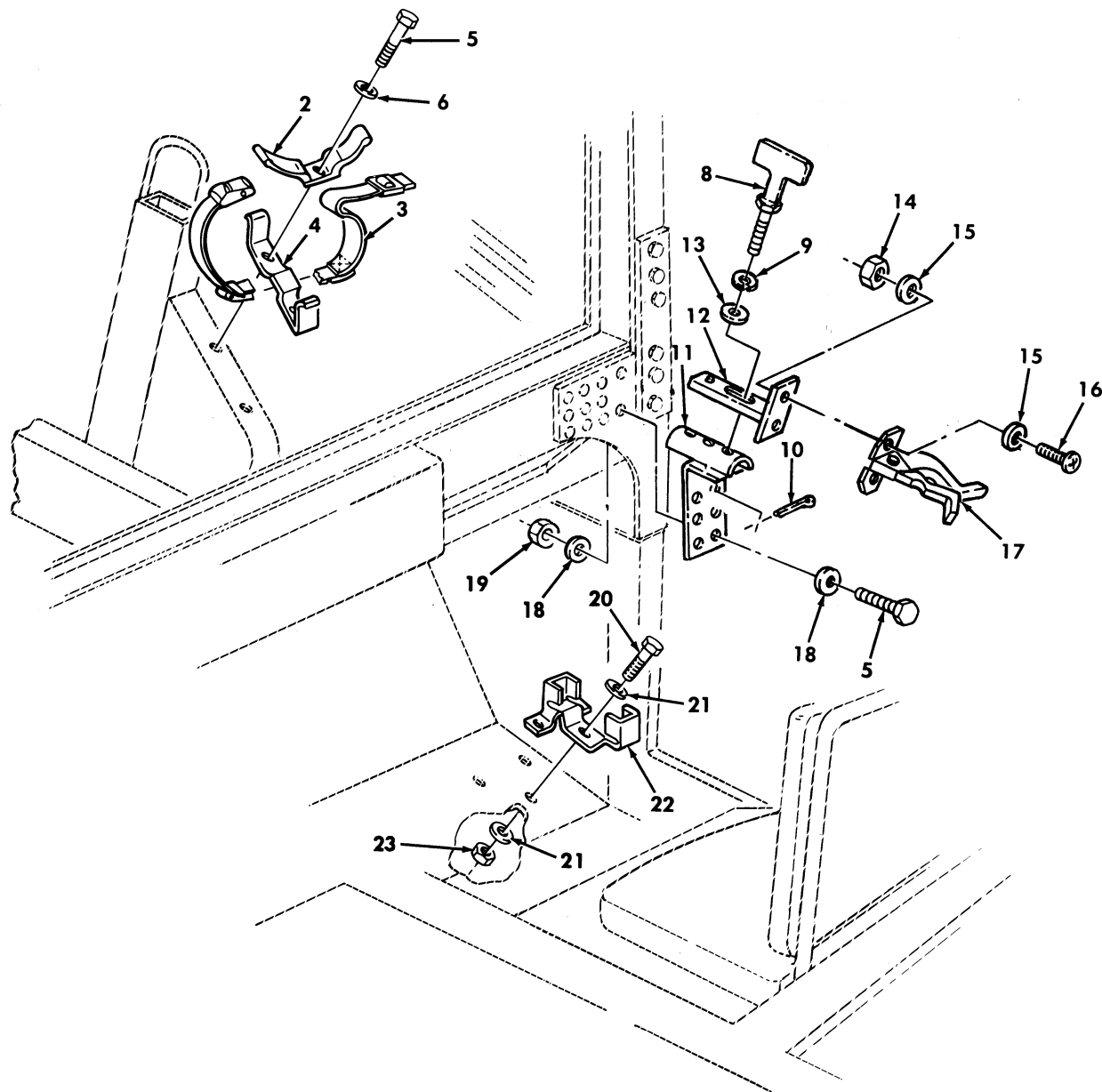
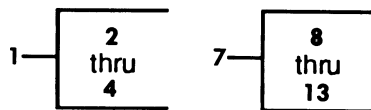
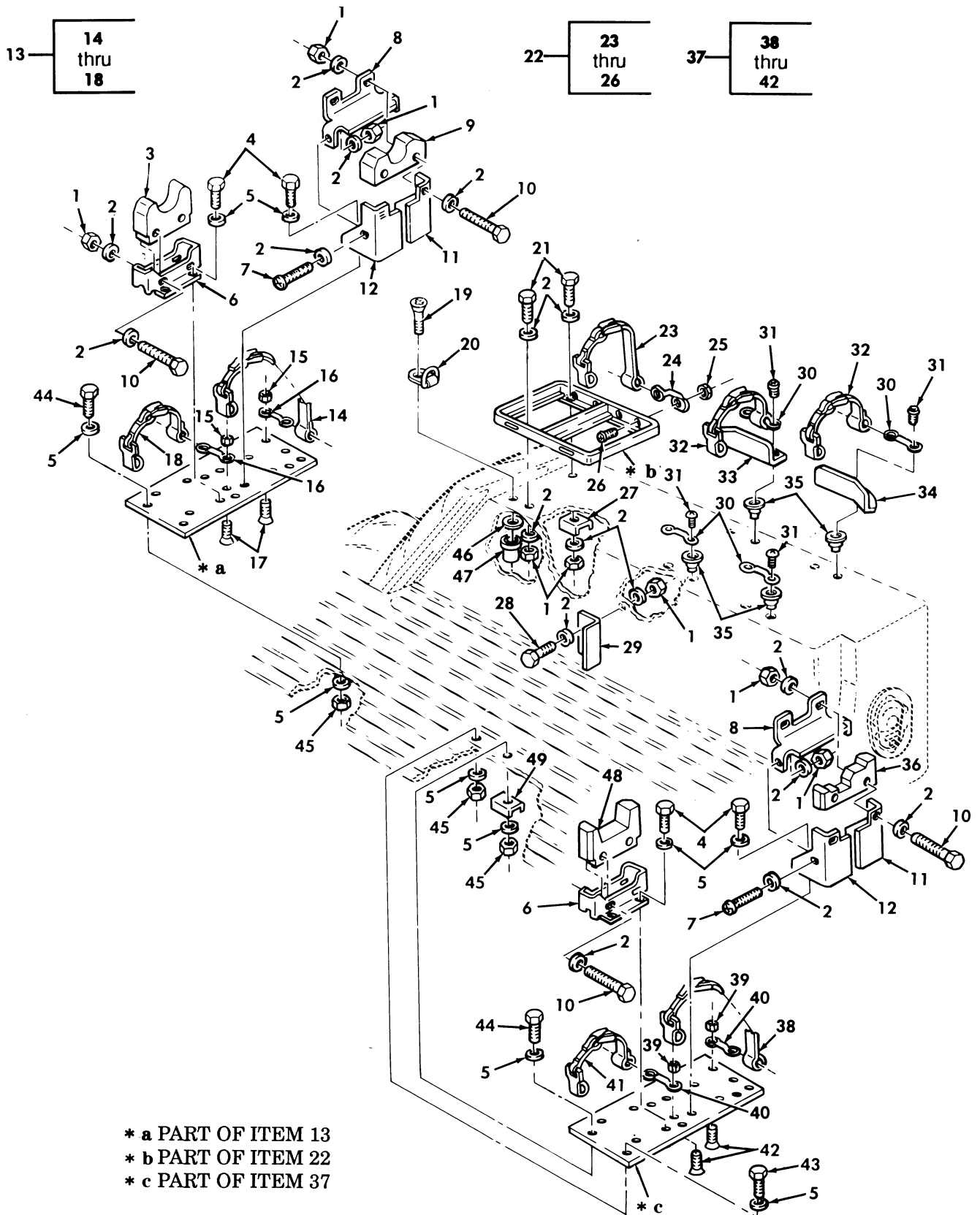

Figure 250. M16/M203 Rifle Mount and Gasoline Burning Stove Stowage.

SECTION II			TM9-2320-280-24P			
(1)	(2)	(3)	(4)	(5)	(6)	(7)
ITEM	SMR			PART		
NO	CODE	NSN	CAGEC	NUMBER	DESCRIPTION AND USABLE ON CODES(UCO)	QTY
					GROUP 1808 STOWAGE RACKS,BOXES, STRAPS,CARRYING CASES,CABLE REELS, HOSE REELS	
					FIG. 250 M16/M203 RIFLE MOUNT AND GASOLINE BURNING STOVE STOWAGE	
1	A0000		31272	45187	CRADLE AND CLAMP.....	1
					UCO:A11,A24,A27,B24,H11,H24,H27,MMM	
2	PAOZZ	2590012100176	31272	45189-10	.SADDLE,RACK.....	2
					UCO:A11,A24,A27,B24,H11,H24,H27,MMM	
3	PAOZZ	5340012097761	31272	45065-10	.STRAP,RETAINING.....	1
					UCO:A11,A24,A27,B24,H11,H24,H27,MMM	
4	PAOZZ	45300121115328	31272	45188-10	.BRACKET FRAME,GASOL.....	1
					UCO:A11,A24,A27,B24,H11,H24,H27,MMM	
5	PAOZZ	5305002253843	80204	B1821BH025C100N	SCREW,CAP,HEXAGON H 1/4-20 X 1.00..	10
					UCO:A11,A24,A27,B24,H11,H24,H27,MMM	
6	PAOZZ	5310011023270	24617	2436161	WASHER,FLAT 1/4.....	2
					UCO:A11,A24,A27,B24,H11,H24,H27,MMM	
7	PAOZZ	2590013776819	19207	12342784	BRACKET,VEHICULAR C.....	2
					UCO:A11,A24,A27,B24,H11,H24,H27,MMM	
8	PAOZZ	5340014766587	19207	12342785	.HANDLE,MANUAL CONTR.....	1
					UCO:A11,A24,A27,B24,H11,H24,H27,MMM	
9	PAOZZ	5310005825965	96906	MS35338-44	.WASHER,LOCK.....	1
					UCO:A11,A24,A27,B24,H11,H24,H27,MMM	
10	PAOZZ	5315008392325	80205	MS24665-132	.PIN,COTTER.....	1
					UCO:A11,A24,A27,B24,H11,H24,H27,MMM	
11	PAOZZ	5340014766205	19207	12342786	.BRACKET,MOUNTING.....	1
					UCO:A11,A24,A27,B24,H11,H24,H27,MMM	
12	PAOZZ	5340014766182	19207	12342787	.BRACKET,MOUNTING.....	1
					UCO:A11,A24,A27,B24,H11,H24,H27,MMM	
13	PAOZZ	5310008094058	96906	MS27183-10	.WASHER,FLAT 1/4.....	1
					UCO:A11,A24,A27,B24,H11,H24,H27,MMM	
14	PAOZZ	5310009416019	96906	MS21083N08	NUT,SELF-LOCKING,HE #8-32.....	4
					UCO:A11,A24,A27,B24,H11,H24,H27,MMM	
15	PAOZZ	5310012134192	7X677	9423534	WASHER,FLAT.....	15
					UCO:A11,A24,A27,B24,H11,H24,H27,MMM	
16	PAOZZ	5305000680502	96906	MS90725-6	SCREW,CAP,HEXAGON H.....	4
					UCO:A11,A24,A27,B24,H11,H24,H27,MMM	
17	PAOZZ	1015012000869	19207	12340487	CLAMP,LOCKING,RECOI.....	2
					UCO:A11,A24,A27,B24,H11,H24,H27,MMM	
18	PAOZZ	5310008094058	96906	MS27183-10	WASHER,FLAT.....	16
					UCO:A11,A24,A27,B24,H11,H24,H27,MMM	
19	PAOZZ	5310000614650	96906	MS51943-31	NUT,SELF-LOCKING,HE.....	8
					UCO:A11,A24,A27,B24,H11,H24,H27,MMM	
20	PAOZZ	5306002258498	96906	MS90725-33	BOLT,MACHINE.....	12
					UCO:A11,A24,A27,B24,H11,H24,H27,MMM	
21	PAOZZ	5310012520512	34623	5592832	WASHER,FLAT.....	24
					UCO:A11,A24,A27,B24,H11,H24,H27,MMM	
22	PFOZZ	2590011942048	19207	12340142	SUPPORT,RIFLE MOUNT.....	2
					UCO:A11,A24,A27,B24,H11,H24,H27,MMM	
23	PAOZZ	5310008140673	96906	MS51943-33	NUT,SELF-LOCKING,HE.....	12
					UCO:A11,A24,A27,B24,H11,H24,H27,MMM	

END OF FIGURE





\* a PART OF ITEM 13  
 \* b PART OF ITEM 22  
 \* c PART OF ITEM 37

Figure 251. Machine Gun, Night Sight, and Ammunition Stowage and Related Components.

SECTION II			TM9-2320-280-24P			
(1)	(2)	(3)	(4)	(5)	(6)	(7)
ITEM NO	SMR CODE	NSN	CAGEC	PART NUMBER	DESCRIPTION AND USABLE ON CODES(UC)	QTY
					GROUP 1808 STOWAGE RACKS,BOXES, STRAPS,CARRYING CASES,CABLE REELS, HOSE REELS	
					FIG. 251 MACHINE GUN,NIGHT SIGHT,AND AMMUNITION STOWAGE AND RELATED COMPONENTS	
1	PAOZZ	5310000614650	96906	MS51943-31	NUT,SELF-LOCKING,HE 1/4-20 (ARMY AND MARINE).....	28
					UC:A25,A26,B25,H25,H26	
2	PAOZZ	5310011023270	24617	2436161	WASHER,FLAT 1/4.....	22
					UC:A25,A26,B17,B18,B25,C17,H17,H18,H25,H26	
3	PFOZZ	1005012526299	19207	12340156	PAD,CUSHIONING (ARMY AND MARINE)...	1
					UC:A25,A26,B17,B18,B25,C17,H17,H18,H25,H26	
4	PAOZZ	5305001159526	96906	MS90725-58	SCREW,CAP,HEXAGON H 3/8-16 X 3/4 (AIR FORCE).....	8
					UC:A25,A26,B25,H25,H26	
4	PAOZZ	5305001159526	96906	MS90725-58	SCREW,CAP,HEXAGON H 3/8-16 X 3/4 (ARMY AND MARINE).....	16
					UC:A25,A26,B25,H25,H26	
5	PAOZZ	5310012057923	34623	5593213	WASHER,FLAT 3/8 (ARMY AND MARINE)...	38
					UC:A25,A26,B17,B18,B25,C17,H17,H18,H25,H26	
5	PFOZZ	5310006419464	70898	100951X031-012-028	WASHER,FLAT 3/8 (AIR FORCE).....	30
					UC:A25,A26,B25,H25,H26	
6	PAOZZ	1005012477916	19207	12340162	BRACE,GUN MOUNT PED (ARMY AND MARINE).....	2
					UC:A25,A26,B17,B18,B25,C17,H17,H18,H25,H26	
7	PAOZZ	5305000711318	96906	MS51957-83	SCREW,MACHINE 1/4-20 X 1.00.....	4
					UC:A25,A26,B17,B18,B25,C17,H17,H18,H25,H26	
8	PAOZZ	1010012477917	19207	12340135	BRACE,GUN MOUNT PED.....	2
					UC:A25,A26,B17,B18,B25,C17,H17,H18,H25,H26	
9	PFOZZ	1010012526300	19207	12340152	PAD,CUSHIONING.....	1
					UC:A25,A26,B17,B18,B25,C17,H17,H18,H25,H26	
10	PAOZZ	5305000712514	80204	B1821BH025C275N	SCREW,CAP,HEXAGON H (ARMY AND MARINE),1/4-20 X 2.75.....	8
					UC:A25,A26,B17,B18,B25,C17,H17,H18,H25,H26	
10	PAOZZ	5305000712514	80204	B1821BH025C275N	SCREW,CAP,HEXAGON H 1/4-20 X 2.75 (AIR FORCE).....	6
					UC:A25,A26,B25,H25,H26	
11	PAOZZ	2590012484874	34623	5593642	SUPPORT,GUN MOUNT R.H.....	2
					UC:A25,A26,B17,B18,B25,C17,H17,H18,H25,H26	
12	PFOZZ	2590012482531	34623	5593641	SUPPORT,GUN MOUNT L.H.....	2
					UC:A25,A26,B17,B18,B25,C17,H17,H18,	

SECTION II			TM9-2320-280-24P			
(1)	(2)	(3)	(4)	(5)	(6)	(7)
ITEM NO	SMR CODE	NSN	CAGEC	PART NUMBER	DESCRIPTION AND USABLE ON CODES(UOC)	QTY
13	PAOOO	5340012477921	19207	12340163	H25,H26 PLATE,MOUNTING.....	1
					UOC:A25,A26,B17,B18,B25,C17,H17,H18, H25,H26	
14	PAOZZ	5340012547190	31272	45410-11	.STRAP,WEBBING.....	1
					UOC:A25,A26,B17,B18,B25,C17,H17,H18, H25,H26	
15	PAOZZ	5310012520481	34623	5593048	.NUT,SELF-LOCKING,HE #10-32.....	4
					UOC:A25,A26,B17,B18,B25,C17,H17,H18, H25,H26	
16	PAOZZ	5340011918186	34623	5582608	.HANDLE,BOW.....	2
					UOC:A25,A26,B17,B18,B25,C17,H17,H18, H25,H26	
17	PAOZZ	5305009847342	96906	MS35191-274	.SCREW,MACHINE #10-32 X 3/4.....	4
					UOC:A25,A26,B17,B18,B25,C17,H17,H18, H25,H26	
18	PAOZZ	5340012586157	31272	45606-11	.STRAP,WEBBING.....	1
					UOC:A25,A26,B17,B18,B25,C17,H17,H18, H25,H26	
19	PAOZZ	5305000522232	96906	MS24667-77	SCREW,CAP,SOCKET HE MACHINE 1/2-13 X 2.00.....	2
					UOC:A25,A26,B17,B18,B25,C17,H17,H18, H25,H26	
20	PAOZZ	3990013148393	19207	12342077	TIE DOWN,CARGO,VEHI.....	2
					UOC:A25,A26,B17,B18,B25,C17,H17,H18, H25,H26	
21	PAOZZ	5305000680502	96906	MS90725-6	SCREW,CAP,HEXAGON H 1/4-20 X 3/4...	4
					UOC:A25,A26,B17,B18,B25,C17,H17,H18, H25,H26	
22	PFOZZ	2540012468292	19207	12340170	BOX,AMMUNITION STOW AMMO TRAY ASSEMBLY.....	1
					UOC:A25,A26,B17,B18,B25,C17,H17,H18, H25,H26	
23	PAOZZ	5340012584529	31272	45410-13	.STRAP,WEBBING.....	2
					UOC:A25,A26,B17,B18,B25,C17,H17,H18, H25,H26	
24	PAOZZ	5340011918186	34623	5582608	.HANDLE,BOW.....	2
					UOC:A25,A26,B17,B18,B25,C17,H17,H18, H25,H26	
25	PAOZZ	5310012520481	34623	5593048	.NUT,SELF-LOCKING,HE #10-32.....	4
					UOC:A25,A26,B17,B18,B25,C17,H17,H18, H25,H26	
26	PAOZZ	5305008213869	80204	B1821BH038C175N	.SCREW,CAP,HEXAGON H #10-32 X 1.75.	4
					UOC:A25,A26,B25,H25,H26	
27	PAOZZ	5340013363004	19207	12342383	BRACKET,ANGLE USBL EFF 100,000 AND ABOVE.....	4
					UOC:A25,A26,B17,B18,B25,C17,H17,H18, H25,H26	
27	PFOZZ	5340012564517	34623	5596028	BRACKET,DOUBLE ANGL USBLE EFF 1 THRU 99,999.....	4
					UOC:A25,A26,B17,B18,B25,C17,H17,H18, H25,H26	
28	PAOZZ	5305000680509	80204	B1821BH025C125N	SCREW,CAP,HEXAGON H 1/4-20 X 1.25..	2

SECTION II			TM9-2320-280-24P			
(1)	(2)	(3)	(4)	(5)	(6)	(7)
ITEM	SMR			PART		
NO	CODE	NSN	CAGEC	NUMBER	DESCRIPTION AND USABLE ON CODES(UOC)	QTY
29	PFOZZ	2590012646531	19207	12340143	UOC:A25,A26,B17,B18,B25,C17,H17,H18, H25,H26 BRACKET,STOP.....	1
30	PAOZZ	5340011918186	34623	5582608	UOC:A25,A26,B17,B18,B25,C17,H17,H18, H25,H26 HANDLE,BOW.....	4
31	PAOZZ	5305009931848	12361	7-099-000154	UOC:A25,A26,B17,B18,B25,C17,H17,H18, H25,H26 SCREW,MACHINE #10-32 X 3/4.....	8
32	PAOZZ	5340012586157	31272	45606-11	UOC:A25,A26,B17,B18,B25,C17,H17,H18, H25,H26 STRAP,WEBBING.....	2
33	PFOZZ	2590012487622	34623	5593609	RETAINER,NIGHT SIG L.H.....	1
34	PFOZZ	2590012487623	19207	12340147-2	UOC:A25,A26,B17,B18,B25,C17,H17,H18, H25,H26 RETAINER,NIGHT SIG R.H.....	1
35	PAOZZ	5310011981723	19207	12339998-14	UOC:A25,A26,B17,B18,B25,C17,H17,H18, H25,H26 NUT,PLAIN,BLIND RIV #10-32.....	8
36	PFOZZ	2590012552957	19207	12340161	UOC:A25,A26,B17,B18,B25,C17,H17,H18, H25,H26 PAD,CUSHIONING.....	1
37	PFOOO	5340012468293	19207	12340154	UOC:A25,A26,B17,B18,B25,C17,H17,H18, H25,H26 PLATE,MOUNTING.....	1
38	PAOZZ	5340012584529	19207	12340507-4	UOC:A25,A26,B17,B18,B25,C17,H17,H18, H25,H26 .STRAP,WEBBING.....	1
39	PAOZZ	5310012520481	34623	5593048	UOC:A25,A26,B17,B18,B25,C17,H17,H18, H25,H26 .NUT,SELF-LOCKING,HE #10-32.....	4
40	PAOZZ	5340011918186	34623	5582608	UOC:A25,A26,B17,B18,B25,C17,H17,H18, H25,H26 .HANDLE,BOW.....	2
41	PAOZZ	5340012611564	31272	45606-10	UOC:A25,A26,B17,B18,B25,C17,H17,H18, H25,H26 .STRAP,WEBBING.....	1
42	PAOZZ	5305009847342	96906	MS35191-274	UOC:A25,A26,B17,B18,B25,C17,H17,H18, H25,H26 .SCREW,MACHINE #10-32 X 3/4.....	4
43	PAOZZ	5305005432419	80204	B1821BH038C113N	UOC:A25,A26,B17,B18,B25,C17,H17,H18, H25,H26 SCREW,CAP,HEXAGON H 3/8-16 X 1.125..	3
44	PAOZZ	5305008213869	80204	B1821BH038C175N	UOC:A25,A26,B17,B18,B25,C17,H17,H18, H25,H26 SCREW,CAP,HEXAGON H 3/8-16 X 1.75..	8
45	PAOZZ	5310009359021	96906	MS51943-35	UOC:A25,A26,B17,B18,B25,C17,H17,H18, H25,H26 NUT,SELF-LOCKING,HE 3/8-16.....	11

SECTION II			TM9-2320-280-24P			
(1)	(2)	(3)	(4)	(5)	(6)	(7)
ITEM NO	SMR CODE	NSN	CAGEC	PART NUMBER	DESCRIPTION AND USABLE ON CODES(UC)	QTY
46	PAOZZ	5310013968392	80205	NAS1149F0863P	WASHER,FLAT 1/2..... UC:A25,A26,B17,B18,B25,C17,H17,H18, H25,H26	2
47	PAOZZ	5310004883889	96906	MS51943-39	NUT,SELF-LOCKING,HE 1/2-13..... UC:A25,A26,B17,B18,B25,C17,H17,H18, H25,H26	2
48	PFOZZ	2590012552958	19207	12340160	PAD,CUSHIONING..... UC:A25,A26,B17,B18,B25,C17,H17,H18, H25,H26	1
49	PFOZZ	5340012590327	34623	5593675	STRAP,RETAINING..... UC:A25,A26,B17,B18,B25,C17,H17,H18, H25,H26	3

END OF FIGURE

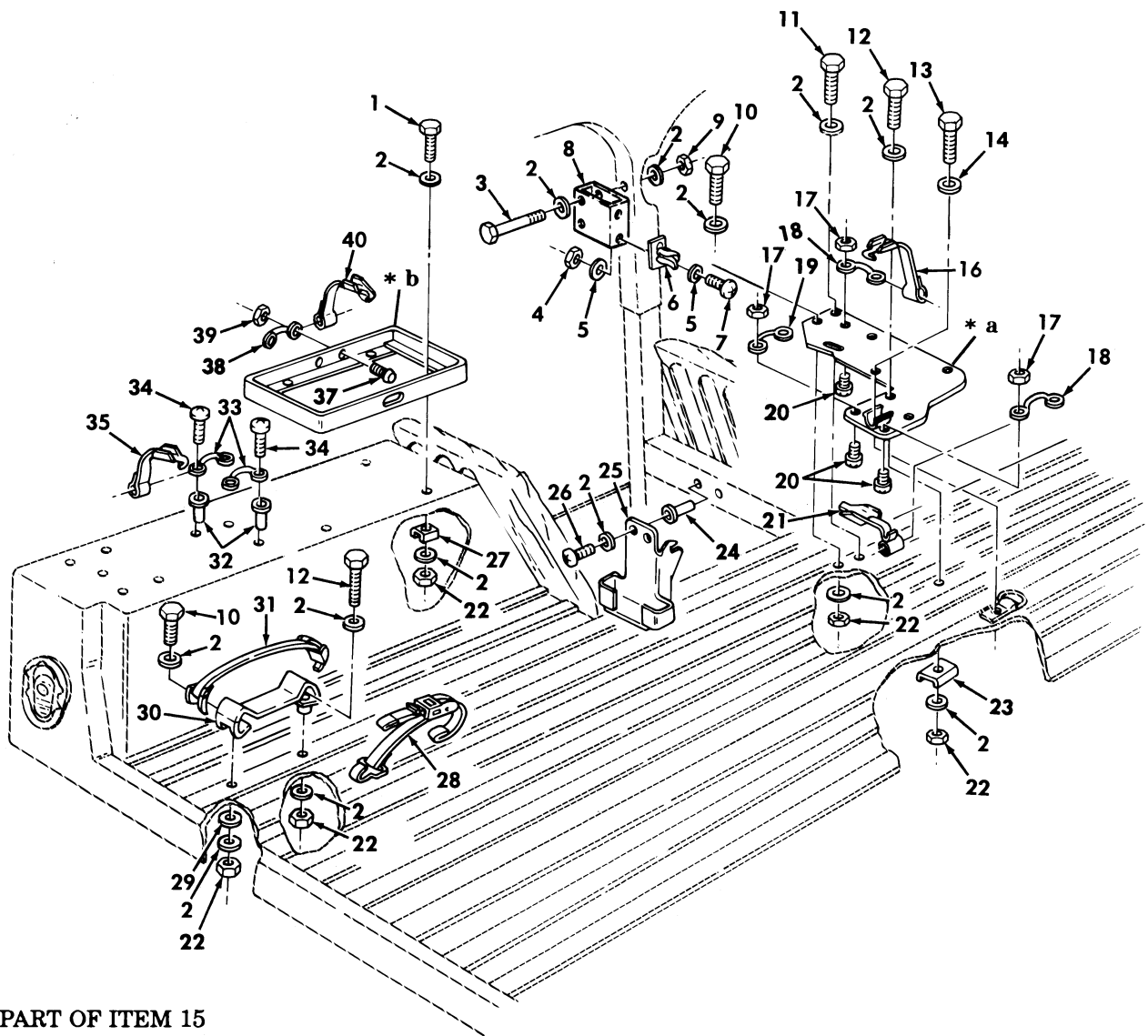

- \* a PART OF ITEM 15
- \* b PART OF ITEM 36

Figure 252. Armament Tripod Mount, Ammunition, Gun Adapter Mount, Rear M16 Rifle Stowage, and Related Components.

SECTION II			TM9-2320-280-24P			
(1)	(2)	(3)	(4)	(5)	(6)	(7)
ITEM	SMR			PART		
NO	CODE	NSN	CAGEC	NUMBER	DESCRIPTION AND USABLE ON CODES(UOC)	QTY
					GROUP 1808 STOWAGE RACKS,BOXES, STRAPS,CARRYING CASES,CABLE REELS, HOSE REELS	
					FIG. 252 ARMAMENT TRIPOD MOUNT AMMUNITION,GUN ADAPTER MOUNT,REAR M16 RIFLE STOWAGE,AND RELATED COMPONENTS	
1	PAOZZ	5305000680502	96906	MS90725-6	SCREW,CAP,HEXAGON H 1/4-20 X 3/4... UOC:A25,A26,B17,B18,B25,C17,H17,H18, H25,H26	4
2	PAOZZ	5310012510748	34623	5593691	WASHER,FLAT 1/4 (MARINE).....	34
2	PAOZZ	5310012510748	34623	5593691	WASHER,FLAT 1/4 (ARMY).....	42
3	PAOZZ	5305000680508	80204	B1821BH025C075N	SCREW,CAP,HEXAGON H 1/4-20 X 2.00 (ARMY).....	2
3	PAOZZ	5305000680508	80204	B1821BH025C075N	SCREW,CAP,HEXAGON H 1/4-20 X 2.00 (MARINE).....	4
4	PAOZZ	5310008113494	96906	MS21044-N08	NUT,SELF-LOCKING,HE #8-32 (MARINE). UOC:A25,A26,B25,H25,H26	4
4	PAOZZ	5310008113494	96906	MS21044-N08	NUT,SELF-LOCKING,HE #8-32 (ARMY)... UOC:B17,B18,C17,H17,H18	2
5	PAOZZ	5310012531618	96906	MS51412-18	WASHER,FLAT #8 (ARMY).....	4
5	PAOZZ	5310012531618	96906	MS51412-18	WASHER,FLAT #8 (MARINE).....	8
6	PAOZZ	1015012000869	19207	12340487	CLAMP,LOCKING,RECOI (MARINE).....	2
6	PAOZZ	1015012000869	19207	12340487	CLAMP,LOCKING,RECOI (ARMY).....	1
7	PAOZZ	5305000546672	96906	MS51957-47	SCREW,MACHINE #8-32 X 3/4.....	4
8	PAOZZ	2590014069821	19207	12446762	BRACKET,VEHICULAR C UPPER, M-16 RIFLE (ARMY).....	1
9	PAOZZ	5310007616882	96906	MS51967-2	NUT,PLAIN,HEXAGON 1/4-20 (ARMY)....	2
9	PAOZZ	5310012552695	34623	5593035	NUT,SELF-LOCKING,HE 1/4-20 (MARINE) UOC:A25,A26,B25,H25,H26	4
10	PAOZZ	5305000712509	80204	B1821BH025C150N	SCREW,CAP,HEXAGON H 1/4-20 X 1.50.. UOC:A25,A26,B17,B18,B25,C17,H17,H18, H25,H26	3
11	PAOZZ	5305000680509	80204	B1821BH025C125N	SCREW,CAP,HEXAGON H 1/4-20 X 1.25.. UOC:A25,A26,B17,B18,B25,C17,H17,H18, H25,H26	2
12	PAOZZ	5305002253843	80204	B1821BH025C100N	SCREW,CAP,HEXAGON H 1/4-20 X 1.00.. UOC:A25,A26,B17,B18,B25,C17,H17,H18, H25,H26	3

SECTION II			TM9-2320-280-24P				
(1)	(2)	(3)	(4)	(5)	(6)	(7)	
ITEM	SMR			PART			
NO	CODE	NSN	CAGEC	NUMBER	DESCRIPTION AND USABLE ON CODES(UC)	QTY	
13	PAOZZ	5305000712071	80204	B1821BH050C200N	SCREW,CAP,HEXAGON H 1/2-13 X 2.00.. UOC:A25,A26,B17,B18,B25,C17,H17,H18, H25,H26	1	
14	PAOZZ	5310001670823	88044	AN960-816	WASHER,FLAT 1/4..... UOC:A25,A26,B17,B18,B25,C17,H17,H18, H25,H26	1	
15	PFOZZ	5340012477922	19207	12340179	PLATE,MOUNTING FRONT..... UOC:A25,A26,B17,B18,B25,C17,H17,H18, H25,H26	1	
16	PAOZZ	5340012645833	31272	45410-20	.STRAP,WEBBING..... UOC:A25,A26,B17,B18,B25,C17,H17,H18, H25,H26	2	
17	PAOZZ	5310012520481	34623	5593048	.NUT,SELF-LOCKING,HE #10-32..... UOC:A25,A26,B17,B18,B25,C17,H17,H18, H25,H26	8	
18	PAOZZ	5340011918186	34623	5582608	.HANDLE,BOW..... UOC:A25,A26,B17,B18,B25,C17,H17,H18, H25,H26	3	
19	PAOZZ	5340011978673	19207	12338839-4	.HANDLE,BOW..... UOC:A25,A26,B17,B18,B25,C17,H17,H18, H25,H26	1	
20	PAOZZ	5305009847342	96906	MS35191-274	.SCREW,MACHINE #10-32 X 3/4..... UOC:A25,A26,B17,B18,B25,C17,H17,H18, H25,H26	8	
21	PAOZZ	5340012590328	31272	45410-12	.STRAP,WEBBING..... UOC:A25,A26,B17,B18,B25,C17,H17,H18, H25,H26	1	
22	PAOZZ	5310000614650	96906	MS51943-31	NUT,SELF-LOCKING,HE 1/4-20..... UOC:A25,A26,B17,B18,B25,C17,H17,H18, H25,H26	10	
23	PFOZZ	5340012584866	19207	12339755-4	STRAP,RETAINING..... UOC:A25,A26,B17,B18,B25,C17,H17,H18, H25,H26	1	
24	PAOZZ	4931012028692	19207	12339998-13	PLUSNUT..... UOC:A25,A26,B17,B18,B25,C17,H17,H18, H25,H26	4	
25	PAOZZ	5340012477918	19207	12340164	BRACKET,MOUNTING LOWER (ARMY)..... UOC:A25,A26,B17,B18,B25,C17,H17,H18, H25,H26	1	
26	PAOZZ	5305000711318	96906	MS51957-83	SCREW,MACHINE 1/4-20 X 1.00..... UOC:A25,A26,B17,B18,B25,C17,H17,H18, H25,H26	4	
27	PAOZZ	5340013363004	19207	12342383	BRACKET,ANGLE USBL EFF 100,000 AND ABOVE..... UOC:A25,A26,B17,B18,B25,C17,H17,H18, H25,H26	1	
27	PFOZZ	5340012564517	34623	5596028	BRACKET,DOUBLE ANGL USBL EFF 1 THRU 99,999..... UOC:A25,A26,B17,B18,B25,C17,H17,H18, H25,H26	4	
27	PFOZZ	5340012564517	34623	5596028	BRACKET,DOUBLE ANGL USBL EFF 100, 000 AND ABOVE..... UOC:A25,A26,B17,B18,B25,C17,H17,H18,	3	



SECTION II			TM9-2320-280-24P			
(1)	(2)	(3)	(4)	(5)	(6)	(7)
ITEM	SMR			PART		
NO	CODE	NSN	CAGEC	NUMBER	DESCRIPTION AND USABLE ON CODES(UOC)	QTY
28	PAOZZ	5340012992963	31272	45685-10	H25, H26 STRAP, WEBBING.....	1
					UOC:A25, A26, B17, B18, B25, C17, H17, H18, H25, H26	
29	PAOZZ	5310012183190	19207	12339433	WASHER, FLAT.....	2
					UOC:A25, A26, B17, B18, B25, C17, H17, H18, H25, H26	
30	PAOZZ	5340012477919	19207	12340314	BRACKET, MOUNTING.....	2
					UOC:A25, A26, B17, B18, B25, C17, H17, H18, H25, H26	
31	PAOZZ	5340012588609	31272	45607-10	STRAP, WEBBING.....	2
					UOC:A25, A26, B17, B18, B25, C17, H17, H18, H25, H26	
32	PAOZZ	5310011981723	19207	12339998-14	NUT, PLAIN, BLIND RIV #10-32.....	8
					UOC:A25, A26, B17, B18, B25, C17, H17, H18, H25, H26	
33	PAOZZ	5340011918186	34623	5582608	HANDLE, BOW.....	4
					UOC:A25, A26, B17, B18, B25, C17, H17, H18, H25, H26	
34	PAOZZ	5305009931848	96906	MS35207-265	SCREW, MACHINE #10-32 X 3/4.....	8
					UOC:A25, A26, B17, B18, B25, C17, H17, H18, H25, H26	
35	PAOZZ	5340012590328	31272	45410-12	STRAP, WEBBING.....	2
					UOC:A25, A26, B17, B18, B25, C17, H17, H18, H25, H26	
36	PAOOO	2590012468294	19207	12340166	TRAY ASSEMBLY, AMMO.....	1
					UOC:A25, A26, B17, B18, B25, C17, H17, H18, H25, H26	
37	PAOZZ	5305010062052	96906	MS51849-65	.SCREW, MACHINE #10-32 X .62.....	2
					UOC:A25, A26, B17, B18, B25, C17, H17, H18, H25, H26	
38	PAOZZ	5340011918186	34623	5582608	.HANDLE, BOW.....	1
					UOC:A25, A26, B17, B18, B25, C17, H17, H18, H25, H26	
39	PAOZZ	5310012520481	34623	5593048	.NUT, SELF-LOCKING, HE #10-32.....	2
					UOC:A25, A26, B17, B18, B25, C17, H17, H18, H25, H26	
40	PAOZZ	5340012586158	31272	45410-16	.STRAP, WEBBING.....	1
					UOC:A25, A26, B17, B18, B25, C17, H17, H18, H25, H26	

END OF FIGURE

Section II.

TM 9-2320-280-24P-1

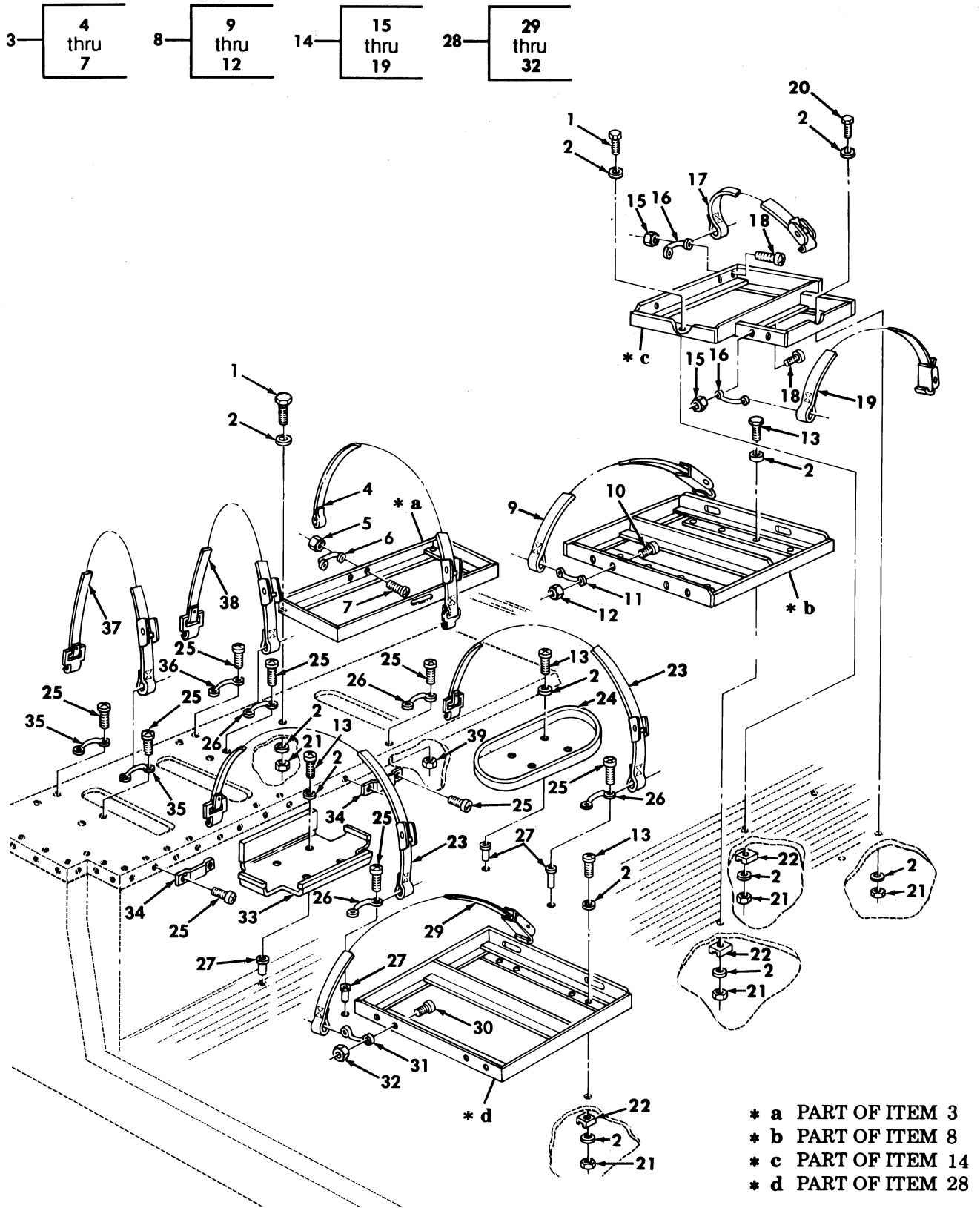

Figure 253. Ammunition and Water Can Stowage Trays and Related Components, Army.

SECTION II			TM9-2320-280-24P			
(1)	(2)	(3)	(4)	(5)	(6)	(7)
ITEM NO	SMR CODE	NSN	CAGEC	PART NUMBER	DESCRIPTION AND USABLE ON CODES(UOC)	QTY
					GROUP 1808 STOWAGE RACKS,BOXES, STRAPS,CARRYING CASES,CABLE REELS, HOSE REELS	
					FIG. 253 AMMUNITION AND WATER CAN STOWAGE TRAYS AND RELATED COMPONENTS,ARMY	
1	PAOZZ	5305000680502	96906	MS90725-6	SCREW,CAP,HEXAGON H 1/4-20 X 3/4...	16
					UOC:B17,B18,H17,H18	
2	PAOZZ	5310008238804	96906	MS27183-9	WASHER,FLAT 1/4.....	88
					UOC:B17,B18,H17,H18	
3	PAOOO	2590012468294	19207	12340166	TRAY ASSEMBLY,AMMO.....	1
					UOC:B17,B18,H17,H18	
4	PAOZZ	5340012586158	31272	45410-16	.STRAP,WEBBING.....	1
					UOC:B17,B18,H17,H18	
5	PAOZZ	5310012520481	34623	5593048	.NUT,SELF-LOCKING,HE #10-32.....	2
					UOC:B17,B18,H17,H18	
6	PAOZZ	5340011918186	34623	5582608	.HANDLE,BOW.....	1
					UOC:B17,B18,H17,H18	
7	PAOZZ	5305000593660	96906	MS51958-64	.SCREW,MACHINE #10-32 X .62.....	2
					UOC:B17,B18,H17,H18	
8	PAOOO	2590012629514	34623	12340175-2	TRAY ASSEMBLY,AMMO.....	1
					UOC:B17,B18,H17,H18	
9	PAOZZ	5340012590329	31272	45410-14	.STRAP,WEBBING.....	2
					UOC:B17,B18,H17,H18	
10	PAOZZ	5305000593660	96906	MS51958-64	.SCREW,MACHINE #10-32 X .62.....	4
					UOC:B17,B18,H17,H18	
11	PAOZZ	5340011918186	34623	5582608	.HANDLE,BOW.....	2
					UOC:B17,B18,H17,H18	
12	PAOZZ	5310012520481	34623	5593048	.NUT,SELF-LOCKING,HE #10-32.....	4
					UOC:B17,B18,H17,H18	
13	PAOZZ	5305000712509	80204	B1821BH025C150N	SCREW,CAP,HEXAGON H 1/4-20 X 1.00..	28
					UOC:B17,B18,H17,H18	
14	PAOOO	2590012629515	34623	5596009	TRAY ASSEMBLY,AMMO.....	1
					UOC:B17,B18,H17,H18	
15	PAOZZ	5310012520481	34623	5593048	.NUT,SELF-LOCKING,HE #10-32.....	6
					UOC:B17,B18,H17,H18	
16	PAOZZ	5340011918186	34623	5582608	.HANDLE,BOW.....	3
					UOC:B17,B18,H17,H18	
17	PAOZZ	5340012590329	31272	45410-14	.STRAP,WEBBING.....	2
					UOC:B17,B18,H17,H18	
18	PAOZZ	5305000593660	96906	MS51958-64	.SCREW,MACHINE #10-32 X .62.....	6
					UOC:B17,B18,H17,H18	
19	PAOZZ	5340012584529	19207	12340507-4	.STRAP,WEBBING.....	1
					UOC:B17,B18,H17,H18	
20	PAOZZ	5305000712509	80204	B1821BH025C150N	SCREW,CAP,HEXAGON H 1/4-20 X 1.50..	6
					UOC:B17,B18,H17,H18	
21	PAOZZ	5310000614650	96906	MS51943-31	NUT,SELF-LOCKING,HE 1/4-20.....	44
					UOC:B17,B18,H17,H18	
22	PAOZZ	5340013363004	19207	12342383	BRACKET,ANGLE USBL EFF 100,000 AND ABOVE.....	1
					UOC:B17,B18	

SECTION II			TM9-2320-280-24P			
(1)	(2)	(3)	(4)	(5)	(6)	(7)
ITEM	SMR			PART		
NO	CODE	NSN	CAGEC	NUMBER	DESCRIPTION AND USABLE ON CODES(UOC)	QTY
22	PFOZZ	5340012564517	34623	5596028	BRACKET,DOUBLE ANGL USBL EFF 1 THRU 99,999..... UOC:H17,H18	8
23	PAOZZ	5340012586157	31272	45606-11	STRAP,WEBBING..... UOC:B17,B18,H17,H18	2
24	PAOZZ	2510011978572	19207	12340155	TRAY,FUEL CAN..... UOC:B17,B18,H17,H18	1
25	PAOZZ	5305012510728	34623	5592823	SCREW,MACHINE #10-32 X .75..... UOC:B17,B18,H17,H18	8
26	PAOZZ	5340011918186	34623	5582608	HANDLE,BOW..... UOC:B17,B18,H17,H18	5
27	PAOZZ	5310011981723	19207	12339998-14	NUT,PLAIN,BLIND RIV #10-32..... UOC:B17,B18,H17,H18	12
28	PAOOO	2590012629513	34623	12340175-3	TRAY ASSEMBLY,AMMO..... UOC:B17,B18,H17,H18	1
29	PAOZZ	5340012758567	31272	45410-19	.STRAP,WEBBING..... UOC:B17,B18,H17,H18	2
30	PAOZZ	5305000593660	96906	MS51958-64	.SCREW,MACHINE #10-32 X .62..... UOC:B17,B18,H17,H18	4
31	PAOZZ	5340011918186	34623	5582608	.HANDLE,BOW..... UOC:B17,B18,H17,H18	2
32	PAOZZ	5310012520481	34623	5593048	.NUT,SELF-LOCKING,HE #10-32..... UOC:B17,B18,H17,H18	4
33	PAOZZ	2540012629516	19207	12340158-3	TRAY,STOWAGE,WATER..... UOC:B17,B18,H17,H18	1
34	PAOZZ	5340012535479	19207	12340130	STRAP,RETAINING..... UOC:B17,B18,H17,H18	2
35	PAOZZ	5340012135735	34623	5591648	LOOP,STRAP FASTENER..... UOC:B17,B18,H17,H18	2
36	PAOZZ	5340011978673	19207	12338839-4	HANDLE,BOW..... UOC:B17,B18,H17,H18	1
37	PAOZZ	5340012547191	31272	45410-10	STRAP,WEBBING..... UOC:B17,B18,H17,H18	1
38	PAOZZ	5340012645833	31272	45410-20	STRAP,WEBBING..... UOC:B17,B18,H17,H18	1
39	PAOZZ	5310012520481	34623	5593048	NUT,SELF-LOCKING,HE #10-32..... UOC:B17,B18,H17,H18	4

END OF FIGURE

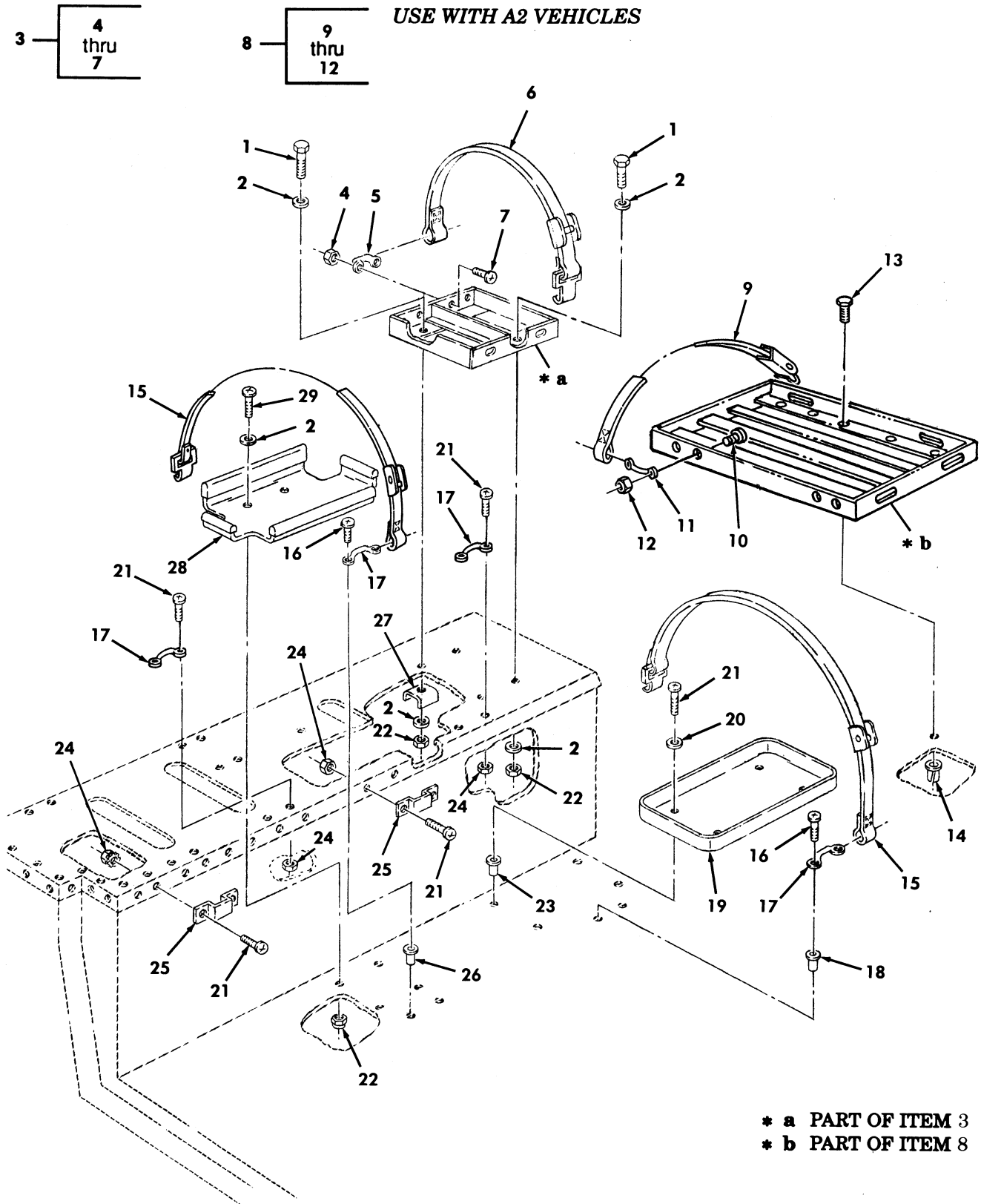
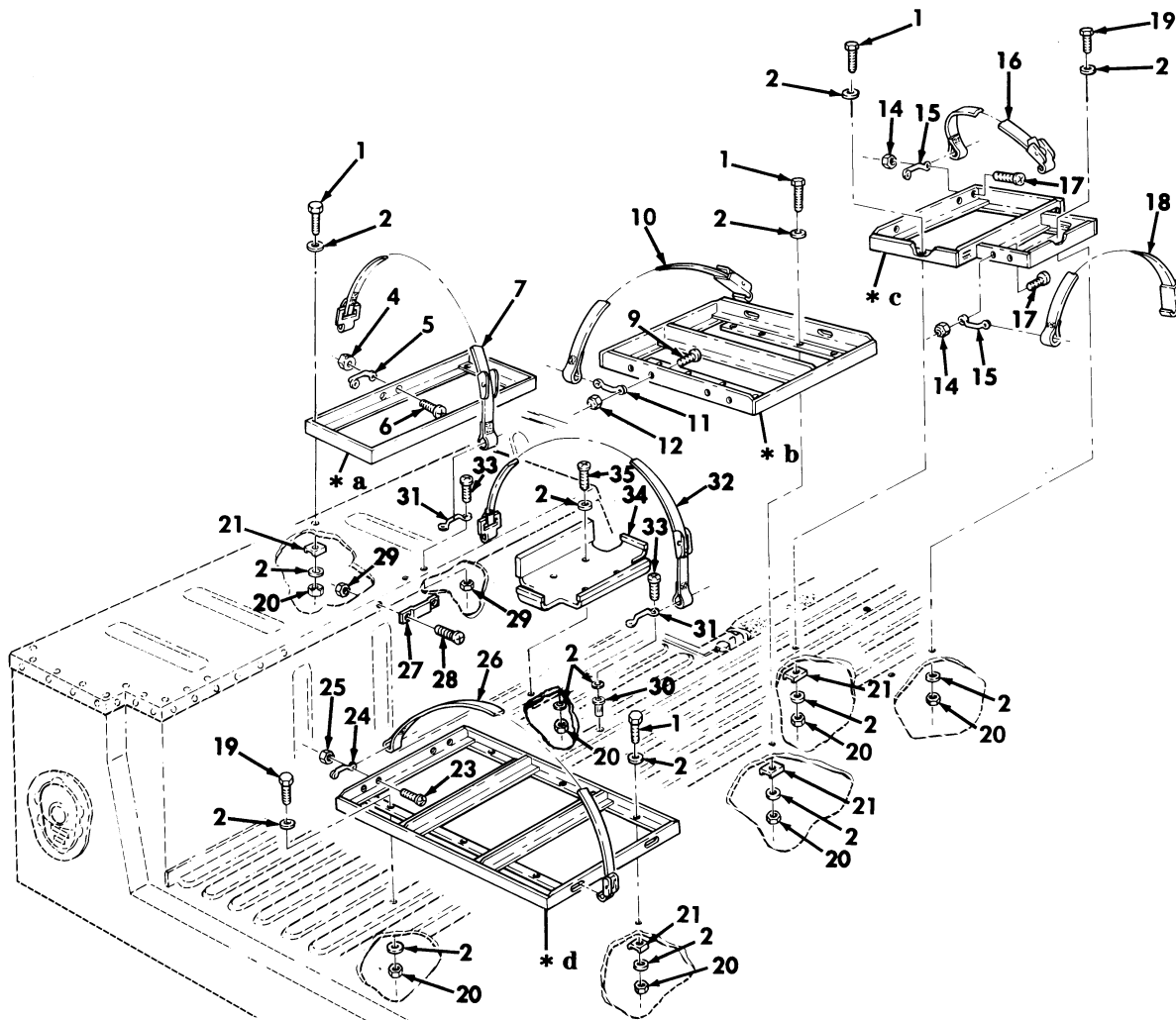
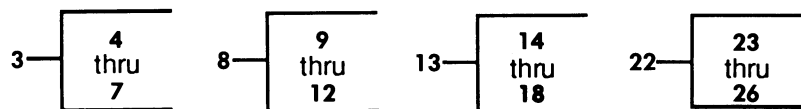

Figure 254. Ammunition and Water Can Stowage Trays and Mounting Hardware.

SECTION II			TM9-2320-280-24P			
(1)	(2)	(3)	(4)	(5)	(6)	(7)
ITEM NO	SMR CODE	NSN	CAGEC	PART NUMBER	DESCRIPTION AND USABLE ON CODES(UC)	QTY
					GROUP 1808 STOWAGE RACKS,BOXES, STRAPS,CARRYING CASES,CABLE REELS, HOSE REELS	
					FIG. 254 AMMUNITION AND WATER CAN STOWAGE TRAYS AND MOUNTING HARDWARE	
1	PAOZZ	5305000680502	96906	MS90725-6	SCREW,CAP,HEXAGON H 1/4-20 X 3/4... UOC:B25,C17	8
2	PAOZZ	5310011023270	24617	2436161	WASHER,FLAT 1/4..... UOC:B25,C17	19
3	PAOZZ	2540012468292	19207	12340170	BOX,AMMUNITION STOW..... UOC:B25,C17	2
4	PAOZZ	5310002514503	24617	9411893	.NUT,LOCK #10-32..... UOC:B25,C17	8
5	PAOZZ	5340013145957	19207	12338839-1	.LOOP,STRAP FASTENER..... UOC:B25,C17	4
6	PAOZZ	5340012584529	19207	12340507-4	.STRAP,WEBBING..... UOC:B25,C17	4
7	PAOZZ	5305000187838	24617	187838	.SCREW,CAP,HEXAGON H..... UOC:B25,C17	8
8	PAOZZ	2540014112737	19207	12446772	BOX,AMMUNITION STOW..... UOC:B25,C17	1
9	PAOZZ	5340012590330	31272	45410-18	.STRAP,WEBBING..... UOC:B25,C17	4
10	PAOZZ	5305000187838	24617	187838	.SCREW,CAP,HEXAGON H #10-32 X .62.. UOC:B25,C17	8
11	PAOZZ	5340013145957	19207	12338839-1	.LOOP,STRAP FASTENER..... UOC:B25,C17	4
12	PAOZZ	5310002514503	24617	9411893	.NUT,LOCK #10-32..... UOC:B25,C17	8
13	PAOZZ	5305002253843	80204	B1821BH025C100N	SCREW,CAP,HEXAGON H 1/4-20 X 1.00.. UOC:B25,C17	6
14	PAOZA	5310010887962	96906	MS27130-A31	NUT,PLAIN,BLIND RIV 1/4-20..... UOC:B25,C17	6
15	PAOZZ	5340012564655	31272	45606-12	STRAP,WEBBING..... UOC:B25,C17	3
16	PAOZZ	5305011850114	7X677	157166	SCREW #10-32 X 3/4..... UOC:B25,C17	6
17	PAOZZ	5340013145957	19207	12338839-1	LOOP,STRAP FASTENER..... UOC:B25,C17	5
18	PAOZZ	5310011981723	03481	S10P175	NUT,PLAIN,BLIND RIV #10-32..... UOC:B25,C17	4
19	PAOZZ	2510011978572	19207	12340155	TRAY,FUEL CAN..... UOC:B25,C17	2
20	PAOZZ	5310011023270	24617	2436161	WASHER,FLAT 1/4..... UOC:B25,C17	8
21	PAOZZ	5305009881727	96906	MS35206-283	SCREW,MACHINE..... UOC:B25,C17	16
22	PAOZZ	5310000614650	96906	MS51943-31	NUT,SELF-LOCKING,HE 1/4-20..... UOC:B25,C17	8
23	PAOZZ	4931012028692	19207	12339998-13	PLUSNUT #10-32..... UOC:B25,C17	8

SECTION II			TM9-2320-280-24P			
(1)	(2)	(3)	(4)	(5)	(6)	(7)
ITEM	SMR			PART		
NO	CODE	NSN	CAGEC	NUMBER	DESCRIPTION AND USABLE ON CODES(UC)	QTY
24	PAOZZ	5310001249265	72582	271169	NUT,PLAIN,ASSEMBLED #10-32..... UOC:B25,C17	4
25	PAOZZ	5340012535479	19207	12340130	STRAP,RETAINING..... UOC:B25,C17	2
26	PAOZZ	5310011976253	25472	S10P320	NUT,PLAIN,BLIND RIV #10-32..... UOC:B25,C17	2
27	PAOZZ	5340013363004	19207	12342383	BRACKET,ANGLE DOUBLE..... UOC:B25,C17	1
28	PAOZZ	2540012629516	19207	12340158-3	TRAY,STOWAGE,WATER..... UOC:B25,C17	1
29	PAOZZ	5305004826825	96906	MS35206-345	SCREW,MACHINE 1/4-20 X 1.38..... UOC:B25,C17	3

END OF FIGURE



- \* a PART OF ITEM 3
- \* b PART OF ITEM 8
- \* c PART OF ITEM 13
- \* d PART OF ITEM 22

Figure 255. Ammunition and Water Can Stowage Trays and Related Components, Air Force and Marine Corps.



SECTION II			TM9-2320-280-24P			
(1)	(2)	(3)	(4)	(5)	(6)	(7)
ITEM NO	SMR CODE	NSN	CAGEC	PART NUMBER	DESCRIPTION AND USABLE ON CODES(UC)	QTY
					GROUP 1808 STOWAGE RACKS,BOXES, STRAPS,CARRYING CASES,CABLE REELS, HOSE REELS	
					FIG. 255 AMMUNITION AND WATER CAN STOWAGE TRAYS AND RELATED COMPONENTS, AIR FORCE AND MARINE CORPS	
1	PAOZZ	5305000680502	96906	MS90725-6	SCREW,CAP,HEXAGON H 1/4-20 X 3/4... UC:A25,A26,B25,H25,H26	12
2	PAOZZ	5310011023270	24617	2436161	WASHER,FLAT 1/4..... UC:A25,A26,B25,H25,H26	44
3	PAOZZ	2590012468294	19207	12340166	TRAY ASSEMBLY,AMMO (AIR FORCE)..... UC:A25,A26,B25,H25,H26	2
4	PAOZZ	5310012520481	34623	5593048	.NUT,SELF-LOCKING,HE #10-32 (AIR FORCE)..... UC:A25,A26,B25,H25,H26	2
5	PAOZZ	5340011918186	34623	5582608	.HANDLE,BOW (AIR FORCE)..... UC:A25,A26,B25,H25,H26	1
6	PAOZZ	5305009897435	96906	MS35207-264	.SCREW,MACHINE #10-32 X .62 (AIR FORCE)..... UC:A25,A26,B25,H25,H26	2
7	PAOZZ	5340012586158	31272	45410-16	.STRAP,WEBBING (AIR FORCE)..... UC:A25,A26,B25,H25,H26	1
8	PAOOO	2590012477923	19207	12340175-1	RACK,AMMUNITION STO..... UC:A25,A26,B25,H25,H26	1
9	PAOZZ	5305000593660	96906	MS51958-64	.SCREW,MACHINE #10-32 X 5/8 (MARINE)..... UC:A25,A26,B25,H25,H26	4
9	PAOZZ	5305000593661	96906	MS51958-65	.SCREW,MACHINE #10-32 X 3/4 (AIR FORCE)..... UC:A25,A26,B25,H25,H26	4
10	PAOZZ	5340012586158	31272	45410-16	.STRAP,WEBBING..... UC:A25,A26,B25,H25,H26	2
11	PAOZZ	5340011918186	34623	5582608	.HANDLE,BOW..... UC:A25,A26,B25,H25,H26	2
12	PAOZZ	5310012520481	34623	5593048	.NUT,SELF-LOCKING,HE #10-32..... UC:A25,A26,B25,H25,H26	4
13	PAOOO	2590012491579	34623	5593189	RACK,AMMUNITION STO..... UC:A25,A26,B25,H25,H26	1
14	PAOZZ	5310012520481	34623	5593048	.NUT,SELF-LOCKING,HE #10-32..... UC:A25,A26,B25,H25,H26	6
15	PAOZZ	5340011918186	34623	5582608	.HANDLE,BOW..... UC:A25,A26,B25,H25,H26	3
16	PAOZZ	5340012590329	31272	45410-14	.STRAP,WEBBING..... UC:A25,A26,B25,H25,H26	2
17	PAOZZ	5305000593661	96906	MS51958-65	.SCREW,MACHINE #10-32 X 3/4 (AIR FORCE)..... UC:A25,A26,B25,H25,H26	6
17	PAOZZ	5305000593660	34623	5592993	.SCREW,MACHINE #10-32 X 5/8 (MARINE)..... UC:A25,A26,H25,H26	6
18	PAOZZ	5340012584529	31272	45410-13	.STRAP,WEBBING.....	1

SECTION II			TM9-2320-280-24P			
(1)	(2)	(3)	(4)	(5)	(6)	(7)
ITEM NO	SMR CODE	NSN	CAGEC	PART NUMBER	DESCRIPTION AND USABLE ON CODES(UOC)	QTY
19	PAOZZ	5305000712509	80204	B1821BH025C150N	UOC:A25,A26,B25,H25,H26 SCREW,CAP,HEXAGON H.....	6
20	PAOZZ	5310000614650	96906	MS51943-31	UOC:A25,A26,B25,H25,H26 NUT,SELF-LOCKING,HE 1/4-20.....	20
21	PAOZZ	5340013363004	19207	12342383	UOC:A25,A26,B25,H25,H26 BRACKET,ANGLE USBL EFF 100,000 AND ABOVE.....	1
21	PFOZZ	5340012564517	19207	12340133	UOC:A25,A26,B25 BRACKET,DOUBLE ANGL USBL EFF 1 THUR 99,999.....	12
22	PFOZZ	2590012477924	19207	12340180	UOC:H25,H26 TRAY ASSEMBLY,AMMO.....	1
23	PAOZZ	5305000593661	96906	MS51958-65	UOC:A25,A26,B25,H25,H26 .SCREW,MACHINE #10-32 X 3/4 (AIR FORCE).....	4
23	PAOZZ	5305000593660	96906	MS51958-64	UOC:A25,A26,B25,H25,H26 .SCREW,MACHINE #10-32 X 5/8 (MARINE).....	4
24	PAOZZ	5340011918186	34623	5582608	UOC:A25,A26,B25,H25,H26 .HANDLE,BOW.....	2
25	PAOZZ	5310012520481	34623	5593048	UOC:A25,A26,B25,H25,H26 .NUT,SELF-LOCKING,HE #10-32.....	4
26	PAOZZ	5340012590330	31272	45410-18	UOC:A25,A26,B25,H25,H26 .STRAP,WEBBING.....	2
27	PFOZZ	5340012535479	19207	12340130	UOC:A25,A26,B25,H25,H26 STRAP,RETAINING.....	1
28	PAOZZ	5305000593661	96906	MS51958-65	UOC:A25,A26,B25,H25,H26 SCREW,MACHINE #10-32 X 3/4.....	2
29	PAOZZ	5310012520481	34623	5593048	UOC:A25,A26,B25,H25,H26 NUT,SELF-LOCKING,HE #10-32.....	4
30	PAOZZ	5310011981723	19207	12339998-14	UOC:A25,A26,B25,H25,H26 NUT,PLAIN,BLIND RIV #10-32.....	2
31	PAOZZ	5340011918186	34623	5582608	UOC:A25,A26,B25,H25,H26 HANDLE,BOW.....	2
32	PAOZZ	5340012586157	31272	45606-11	UOC:A25,A26,B25,H25,H26 STRAP,WEBBING.....	1
33	PAOZZ	5305009931848	96906	MS35207-265	UOC:A25,A26,B25,H25,H26 SCREW,MACHINE #10-32 X 3/4.....	4
34	PAOZZ	2590012477920	19207	12340158-2	UOC:A25,A26,B25,H25,H26 TRAY ASSEMBLY,WATER.....	1
35	PAOZZ	5305001829304	96906	MS51957-131	UOC:A25,A26,B25,H25,H26 SCREW,MACHINE 1/4-20 X 1.375.....	4

END OF FIGURE

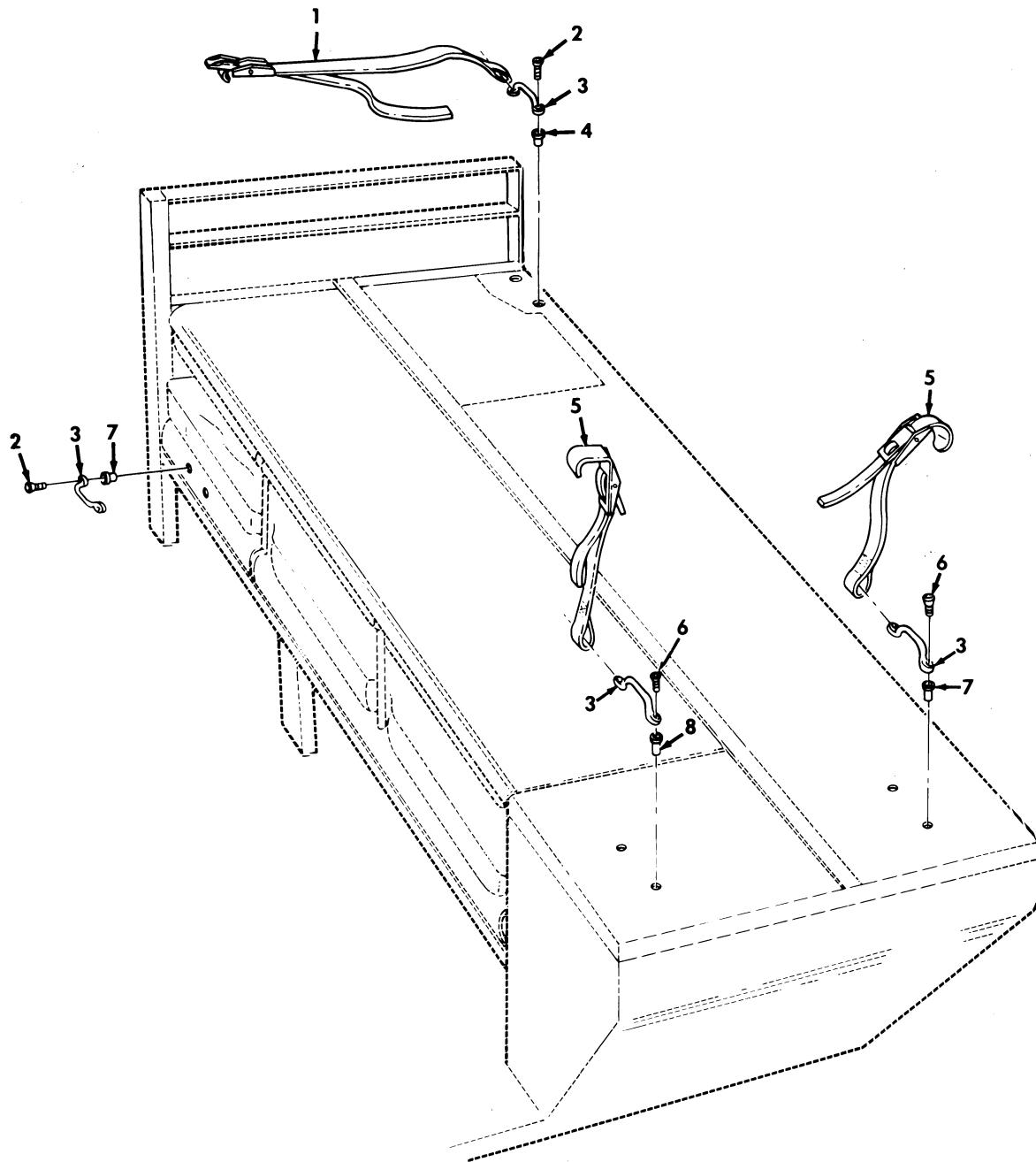

Figure 256. Litter Straps and Fasteners, Right Hand, M996 and M996A1 Ambulance.

SECTION II			TM9-2320-280-24P			
(1)	(2)	(3)	(4)	(5)	(6)	(7)
ITEM NO	SMR CODE	NSN	CAGEC	PART NUMBER	DESCRIPTION AND USABLE ON CODES(UOC)	QTY
					GROUP 1808 STOWAGE RACKS,BOXES, STRAPS,CARRYING CASES,CABLE REELS, HOSE REELS	
					FIG. 256 LITTER STRAPS AND FASTENERS ,RIGHT HAND,M996 AND M996A1 AMUBLANCE	
1	PAOZZ	5340012758568	31272	45410-21	STRAP,WEBBING.....	1
					UOC:B16,H16	
2	PAOZZ	5305009953444	96906	MS35207-266	SCREW,MACHINE #10-32 X 7/8.....	4
					UOC:B16,H16	
3	PAOZZ	5340011918186	34623	5582608	HANDLE,BOW.....	4
					UOC:B16,H16	
4	PAOZZ	5310001777529	34623	5934007	NUT,PLAIN,BLIND RIV #10-32.....	2
					UOC:B16,H16	
5	PAOZZ	5340012658925	31272	45084-11	STRAP,WEBBING.....	2
					UOC:B16,H16	
6	PAOZZ	5305012510728	34623	5592823	SCREW,MACHINE #10-32 X 3/8.....	4
					UOC:B16,H16	
7	PAOZZ	5310005504725	80205	NAS453-10K75	NUT,PLAIN,BLIND RIV #10-32.....	4
					UOC:B16,H16	
8	PAOZZ	5310001413062	96906	MS27130-A26	NUT,INSERT.....	2
					UOC:B16,H16	

END OF FIGURE

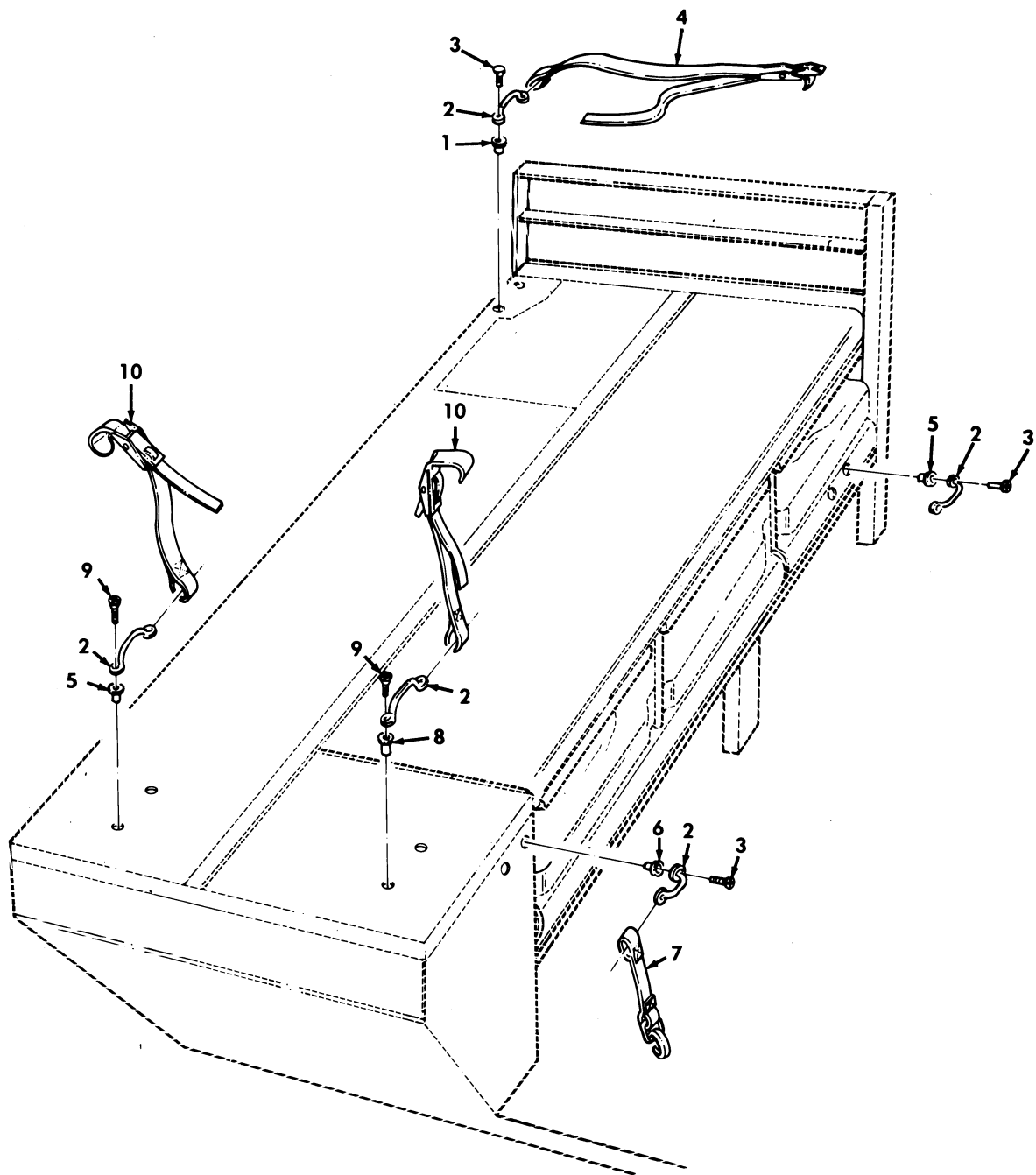

Figure 257. Litter Straps and Fasteners, Right Hand, M996 and M996A1 Ambulance.

SECTION II			TM9-2320-280-24P			
(1)	(2)	(3)	(4)	(5)	(6)	(7)
ITEM	SMR			PART		
NO	CODE	NSN	CAGEC	NUMBER	DESCRIPTION AND USABLE ON CODES(UOC)	QTY
					GROUP 1808 STOWAGE RACKS,BOXES, STRAPS,CARRYING CASES,CABLE REELS, HOSE REELS	
					FIG. 257 LITTER STRAPS AND FASTENERS ,LEFT HAND,M996 AND M996A1 AMBULANCE	
1	PAOZZ	5310001777529	34623	5934007	NUT,PLAIN,BLIND RIV #10-32.....	2
					UOC:B16,H16	
2	PAOZZ	5340011918186	34623	5582608	HANDLE,BOW.....	5
					UOC:B16,H16	
3	PAOZZ	5305009953444	96906	MS35207-266	SCREW,MACHINE #10-32 X 7/8.....	6
					UOC:B16,H16	
4	PAOZZ	5340012758568	31272	45410-21	STRAP,WEBBING.....	1
					UOC:B16,H16	
5	PAOZZ	5310004604490	96906	MS27130-S37	NUT,PLAIN,BLIND RIV #10-32.....	4
					UOC:B16,H16	
6	PAOZZ	5310006820775	80205	NAS1329A3K280	NUT,PLAIN,BLIND RIV #10-32.....	2
					UOC:B16,H16	
7	PAOZZ	5340012723403	31272	44647-22	STRAP,WEBBING.....	1
					UOC:B16,H16	
8	PAOZZ	5310001413062	96906	MS27130-A26	NUT,PLAIN,BLIND RIV #10-32.....	2
					UOC:B16,H16	
9	PAOZZ	5305012510728	34623	5592823	SCREW,MACHINE #10-32 X .75.....	4
					UOC:B16,H16	
10	PAOZZ	5340012658925	31272	45084-11	STRAP,WEBBING.....	2
					UOC:B16,H16	

END OF FIGURE

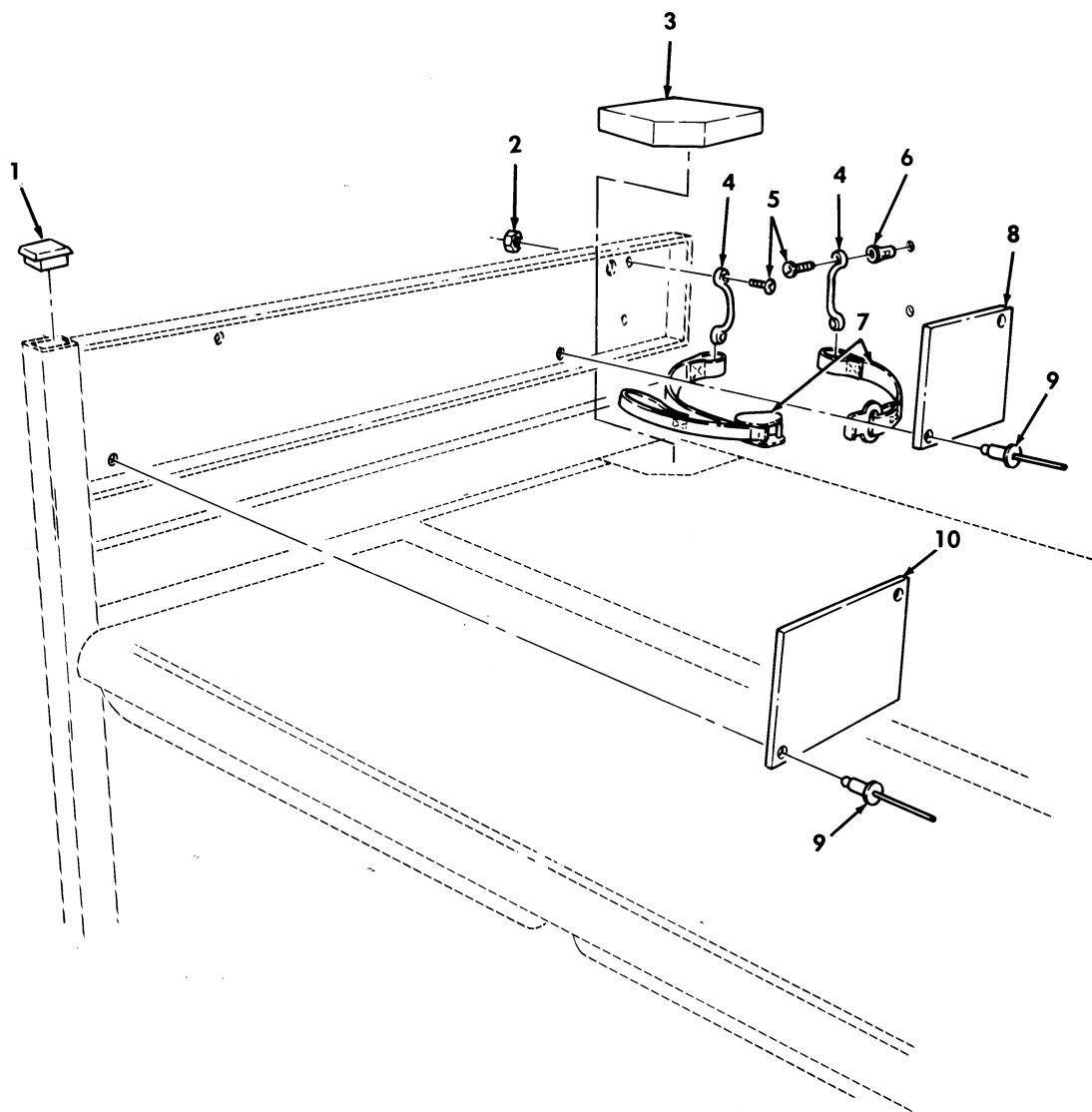

Figure 258. Oxygen Bottle Mounting, Litter Bumpers, and Litter Frame Plugs, Right Hand, M996 and M996A1 Ambulance.

SECTION II			TM9-2320-280-24P			
(1)	(2)	(3)	(4)	(5)	(6)	(7)
ITEM NO	SMR CODE	NSN	CAGEC	PART NUMBER	DESCRIPTION AND USABLE ON CODES(UC)	QTY
					GROUP 1808 STOWAGE RACKS,BOXES, STRAPS,CARRYING CASES,CABLE REELS, HOSE REELS	
					FIG. 258 OXYGEN BOTTLE MOUNTING, LITTER BUMPERS,AND LITTER FRAME PLUGS,RIGHT HAND,M996 AND M996A1 AMBULANCE	
1	PAOZZ	5340012747337	95760	FP-161	PLUG,PROTECTIVE,DUS.....	1
					UOC:B16,H16	
2	PAOZZ	5310012510726	34623	5593053	NUT,SELF-LOCKING,HE #10-32.....	2
					UOC:B16,H15,H16	
3	PAOZZ	5340012775129	34623	SF5597714	BUMPER,NONMETALLIC.....	1
					UOC:B16,H16	
4	PAOZZ	5340011918186	34623	5582608	HANDLE,BOW.....	2
					UOC:B16,H16	
5	PAOZZ	5305009897435	96906	MS35207-264	SCREW,MACHINE #10-32 X 5/8.....	4
					UOC:B16,H16	
6	PAOZZ	5310004015321	96906	MS27130-A32	NUT,PLAIN,BLIND RIV #10-32.....	2
					UOC:B16,H16	
7	PAOZZ	5340012658923	31272	44647-18	STRAP,WEBBING.....	1
					UOC:B16,H16	
8	PAOZZ	5340012708432	19207	12341500-1	BUMPER,PLASTIC.....	1
					UOC:B16,H16	
9	PAOZZ	5320010849234	11815	CR-213-6-6	RIVET,BLIND 3/16.....	4
					UOC:B16,H16	
10	PAOZZ	5340012708431	19207	12341500-3	BUMPER,PLASTIC.....	1
					UOC:B16,H16	

END OF FIGURE



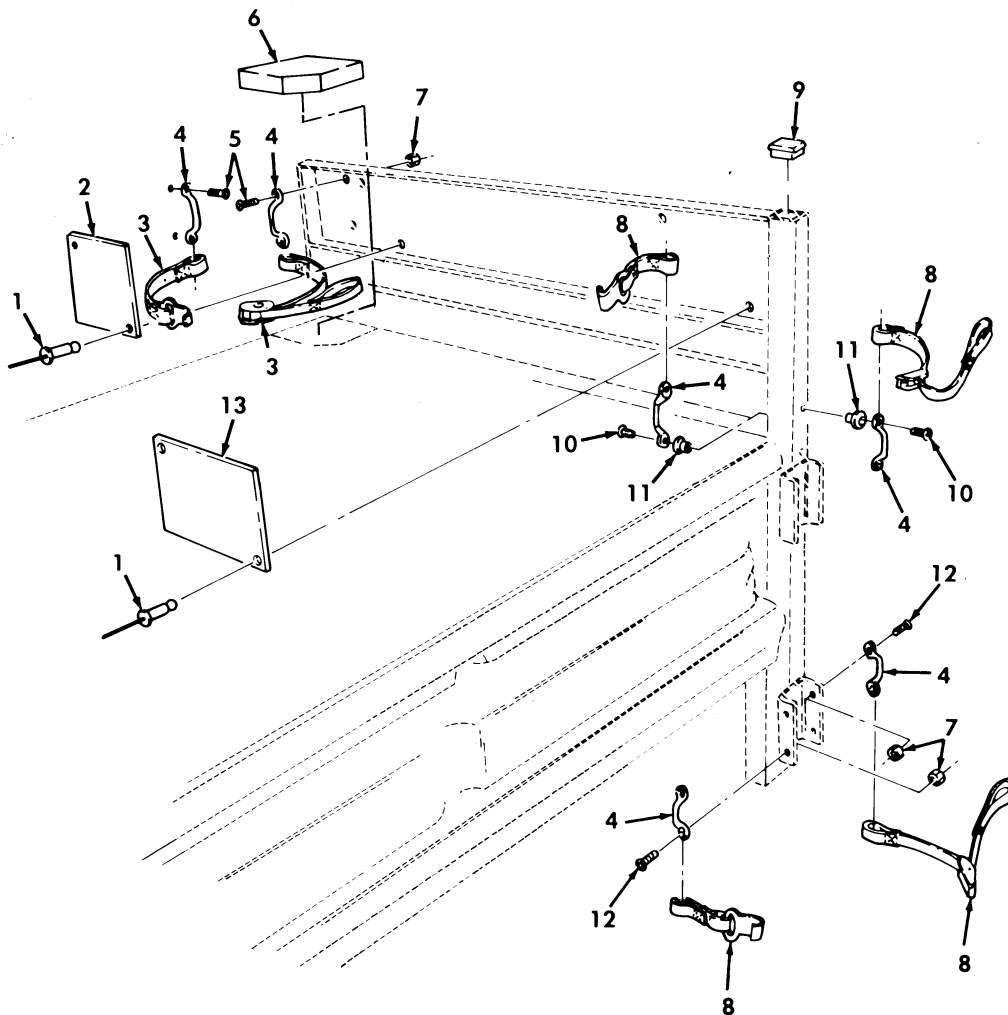

Figure 259. Oxygen Bottle Mounting, Litter Bumpers, and Litter Frame Plugs, Left Hand, M996 and M996A1 Ambulance.

SECTION II			TM9-2320-280-24P			
(1)	(2)	(3)	(4)	(5)	(6)	(7)
ITEM NO	SMR CODE	NSN	CAGEC	PART NUMBER	DESCRIPTION AND USABLE ON CODES(UC)	QTY
					GROUP 1808 STOWAGE RACKS,BOXES, STRAPS,CARRYING CASES,CABLE REELS, HOSE REELS	
					FIG. 259 OXYGEN BOTTLE MOUNTING, LITTER BUMPERS,AND LITTER FRAME PLUGS,LEFT HAND,M996 AND M996A1 AMBULANCE	
1	PAOZZ	5320010849234	11815	CR-213-6-6	RIVET,BLIND 3/16.....	4
					UOC:B16,H16	
2	PAOZZ	5340012774619	34623	5933977	BUMPER,NONMETALLIC.....	1
					UOC:B16,H16	
3	PAOZZ	5340012658923	31272	44647-18	STRAP,WEBBING.....	1
					UOC:B16,H16	
4	PAOZZ	5340011918186	34623	5582608	HANDLE,BOW.....	6
					UOC:B16,H16	
5	PAOZZ	5305000593660	96906	MS51958-64	SCREW,MACHINE #10-32 X 5/8.....	4
					UOC:B16,H16	
6	PAOZZ	5340012775129	34623	SF5597714	BUMPER,NONMETALLIC.....	1
					UOC:B16,H16	
7	PAOZZ	5310012510726	34623	5593053	NUT,SELF-LOCKING,HE #10-32.....	6
					UOC:B16,H16	
8	PAOZZ	5340012728431	31272	44647-19	STRAP,WEBBING.....	2
					UOC:B16,H16	
9	PAOZZ	5340012747337	95760	FP-161	PLUG,PROTECTIVE,DUS.....	1
					UOC:B16,H16	
10	PAOZZ	5305012510728	34623	5592823	SCREW,MACHINE #10-32 X 3/4.....	4
					UOC:B16,H16	
11	PAOZZ	5310001413062	96906	MS27130-A26	NUT,PLAIN,BLIND RIV #10-32.....	4
					UOC:B16,H16	
12	PAOZZ	5305001804966	96906	MS51849-64	SCREW,MACHINE #10-32 X .50.....	4
					UOC:B16,H16	
13	PAOZZ	5340012708431	19207	12341500-3	BUMPER,PLASTIC.....	1
					UOC:B16,H16	

END OF FIGURE

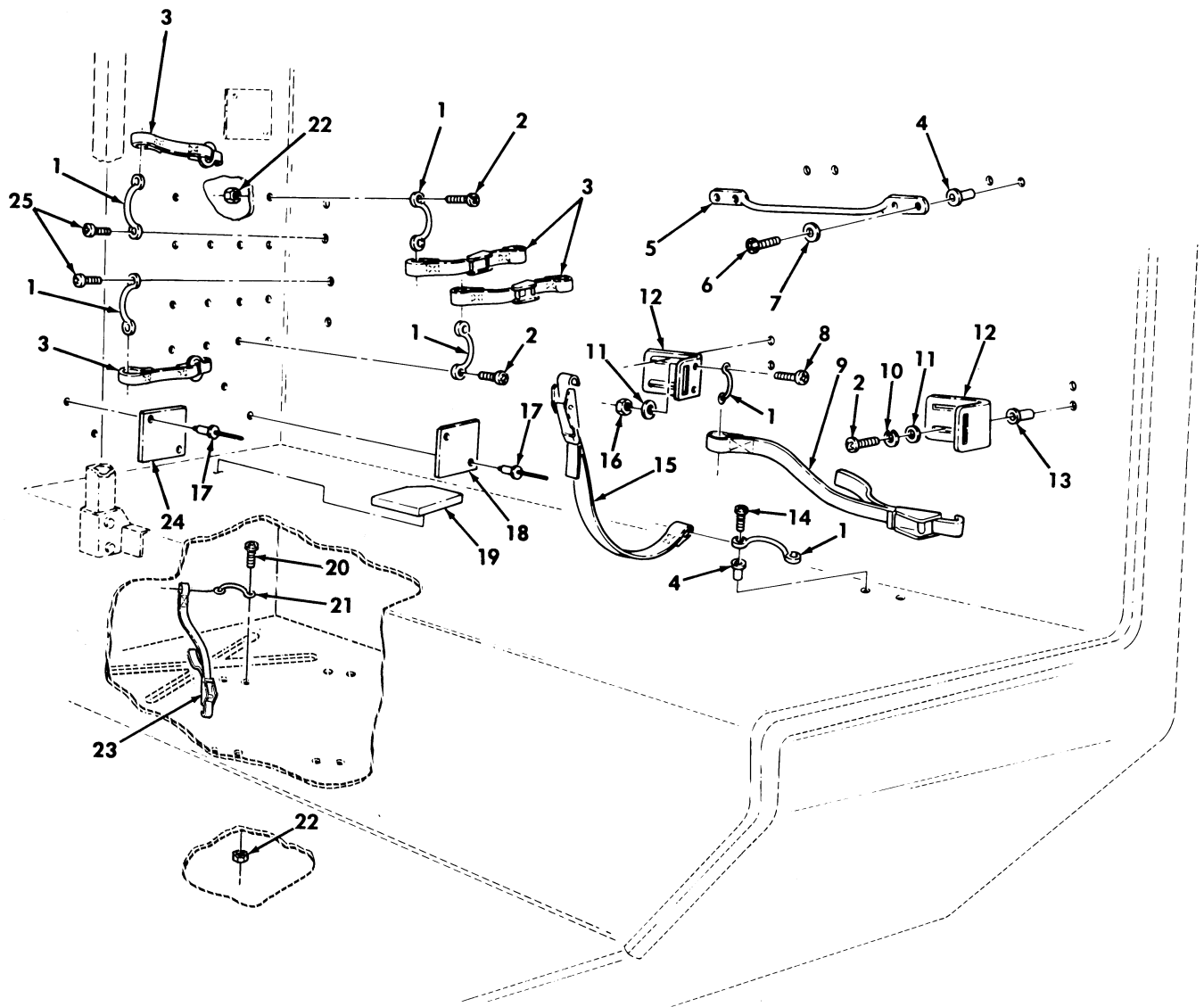

Figure 260. Oxygen Bottle Holddown and Bracket, Spine Board (Short) W/Straps, R.H., M997, M997A1, and M997A2 Ambulance.

SECTION II			TM9-2320-280-24P			
(1)	(2)	(3)	(4)	(5)	(6)	(7)
ITEM	SMR			PART		
NO	CODE	NSN	CAGEC	NUMBER	DESCRIPTION AND USABLE ON CODES(UOC)	QTY
					GROUP 1808 STOWAGE RACKS,BOXES, STRAPS,CARRYING CASES,CABLE REELS, HOSE REELS	
					FIG. 260 OXYGEN BOTTLE HOLDDOWN AND BRACKET,SPINE BOARD (SHORT) W/STRAPS, R.H.,M997,M997A1,AND M997A2 AMBULANCE	
1	PAOZZ	5340011918186	34623	5582608	HANDLE,BOW.....	13
					UOC:A15,B15,H15	
2	PAOZZ	5305000593660	96906	MS51958-64	SCREW,MACHINE #10-32 X 5/8.....	24
					UOC:A15,B15,H15	
3	PAOZZ	5340012658923	31272	44647-18	STRAP,WEBBING.....	4
					UOC:A15,B15,H15	
4	PAOZZ	5310001777529	34623	5934007	NUT,PLAIN,BLIND RIV #10-32.....	6
					UOC:A15,B15,H15	
5	PAOZZ	5340012730136	19207	12341490	STRAP,RETAINING.....	1
					UOC:A15,B15,H15	
6	PAOZZ	5305012725433	34623	5593390	SCREW,MACHINE #10-32 X 1.00.....	12
					UOC:A15,B15,H15	
7	PAOZZ	5310012349416	96906	MS51412-2	WASHER,FLAT #10.....	8
					UOC:A15,B15,H15	
8	PAOZZ	5305009897435	96906	MS35207-264	SCREW,MACHINE #10-32 X 5/8.....	2
					UOC:A15,B15,H15	
9	PAOZZ	5340012727815	31272	45410-22	STRAP,WEBBING.....	1
					UOC:A15,B15,H15	
10	PAOZZ	5310000453296	96906	MS35338-43	WASHER,LOCK 3/16.....	8
					UOC:A15,B15,H15	
11	PAOZZ	5310012531618	96906	MS51412-18	WASHER,FLAT #10.....	6
					UOC:A15,B15,H15	
12	PAOZZ	5340012743287	34623	5597820	BRACKET,ANGLE.....	2
					UOC:A15,B15,H15	
13	PAOZZ	5310000036779	96906	MS27130-A27	NUT,PLAIN,BLIND RIV #10-32.....	4
					UOC:A15,B15,H15	
14	PAOZZ	5305009953444	96906	MS35207-266	SCREW,MACHINE #10-32 X 7/8.....	12
					UOC:A15,B15,H15	
15	PAOZZ	5340012878761	31272	45084-12	STRAP,WEBBING.....	1
					UOC:A15,B15,H15	
16	PAOZZ	5310002514503	24617	9411893	NUT,LOCK #10-32.....	2
					UOC:A15,B15,H15	
17	PAOZZ	5320010849234	11815	CR-213-6-6	RIVET,BLIND 3/16.....	8
					UOC:A15,B15,H15	
18	PAOZZ	5340012708432	34623	SF5934173	BUMPER,PLASTIC.....	2
					UOC:A15,B15,H15	
19	PAOZZ	5340012775129	34623	SF5597714	BUMPER,NONMETALLIC.....	2
					UOC:A15,B15,H15	
20	PAOZZ	5305011850114	7X677	157166	SCREW,CAP,HEXAGON H #10-32 X 3/4...	8
					UOC:A15,B15,H15	
21	PAOZZ	5340014341809	19207	12338839-3	LOOP,STRAP,FASTENER.....	4
					UOC:A15,B15,H15	
22	PAOZZ	5310001249265	72582	271169	NUT,PLAIN,ASSEMBLED #10-32.....	8
					UOC:A15,B15,H15	

SECTION II			TM9-2320-280-24P			
(1)	(2)	(3)	(4)	(5)	(6)	(7)
ITEM	SMR			PART		
NO	CODE	NSN	CAGEC	NUMBER	DESCRIPTION AND USABLE ON CODES(UC)	QTY
23	PAOZZ	5340012586158	31272	45410-16	STRAP,WEBBING.....	2
					UOC:A15,B15,H15	
24	PAOZZ	5340012708431	19207	12341500-3	BUMPER,PLASTIC.....	2
					UOC:A15,B15,H15	
25	PAOZZ	5305011850114	7X677	157166	SCREW #10-32 X 3/4.....	4
					UOC:A15,B15,H15	

END OF FIGURE

6 — 

7 thru 15
-----------------

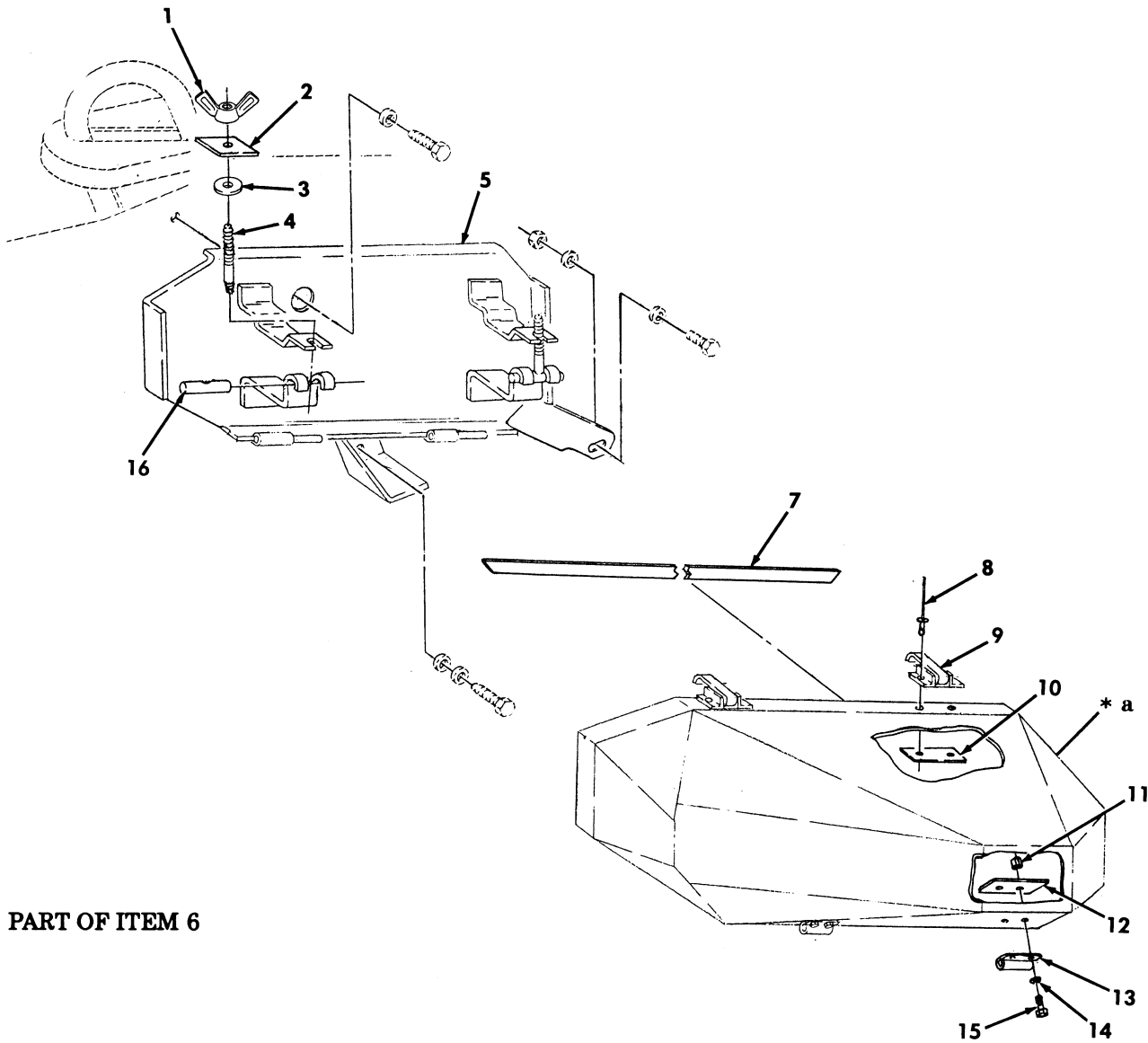

\* a PART OF ITEM 6

Figure 261. 3-1/2 Ton Jack Storage Bracket and Related Items.

SECTION II			TM9-2320-280-24P			
(1)	(2)	(3)	(4)	(5)	(6)	(7)
ITEM	SMR			PART		
NO	CODE	NSN	CAGEC	NUMBER	DESCRIPTION AND USABLE ON CODES(UOC)	QTY
					GROUP 1808 STOWAGE RACKS,BOXES, STRAPS,CARRYING CASES,CABLE REELS, HOSE REELS	
					FIG. 261 3-1/2 TON JACK STORAGE BRACKET AND RELATED ITEMS	
1	PAOZZ	5310010785996	96906	MS35425-75	NUT,PLAIN,WING.....	2
					UOC:BVY,B15,B20,B24,B25,C17,NNN	
2	PAOZZ	5365014088507	19207	12447037	SPACER,PLATE.....	2
					UOC:BVY,B15,B20,B24,B25,C17,NNN	
3	PAOZZ	5310013744512	19207	12412123	WASHER,FLAT 3/8.....	2
					UOC:BVY,B15,B20,B24,B25,C17,NNN	
4	PAOZZ	5307014118340	19207	12447035	STUD,STEPPED THRU.....	2
					UOC:BVY,B15,B20,B24,B25,C17,NNN	
5	PAOZZ	2590014109967	19207	12446993	BRACKET,VEHICULAR C.....	1
					UOC:BVY,B15,B20,B24,B25,C17,NNN	
6	PAOZZ	2590014108791	19207	12446998	COVER,VEHICULAR COM.....	1
					UOC:BVY,B15,B20,B24,B25,C17,NNN	
7	MOOZZ		19207	12338807-4	.SEAL MAKE FROM SEAL, P/N 68- 412121-1, 81.50 INCHES LONG.....	1
					UOC:BVY,B15,B20,B24,B25,C17,NNN	
8	PAOZZ	5320012716357	9K475	MGLP-B6-4	.RIVET,BLIND 3/16.....	4
					UOC:BVY,B15,B20,B24,B25,C17,NNN	
9	PAOZZ	5340014088508	19207	12339664	.CATCH,CLAMPING LEVER,LOCK-RELEASE.	2
					UOC:BVY,B15,B20,B24,B25,C17,NNN	
10	PAOZZ	5340014088509	19207	12447000	.PLATE,MOUNTING.....	2
					UOC:BVY,B15,B20,B24,B25,C17,NNN	
11	PAOZZ	5310014326727	24617	9419471	.NUT,SELF-LOCKING,HE 1/4-20.....	4
					UOC:BVY,B15,B20,B24,B25,C17,NNN	
12	PAOZZ	5340014088512	19207	12446999	.PLATE,MOUNTING.....	2
					UOC:BVY,B15,B20,B24,B25,C17,NNN	
13	PAOZZ	5340014087091	19207	7397934	.LEAF,BUTT HINGE.....	2
					UOC:BVY,B15,B20,B24,B25,C17,NNN	
14	PAOZA	5310008174623	98465	4M25-4	.WASHER,FLAT 1/4.....	4
					UOC:BVY,B15,B20,B24,B25,C17,NNN	
15	PAOZZ	5305014114456	24617	173397	.SCREW,CAP,HEXAGON H 1/4-20 X 5/8..	4
					UOC:BVY,B15,B20,B24,B25,C17,NNN	
16	PAOZZ	5315014087089	19207	12447036	PIN,HOLLOW.....	2
					UOC:BVY,B15,B20,B24,B25,C17,NNN	

END OF FIGURE

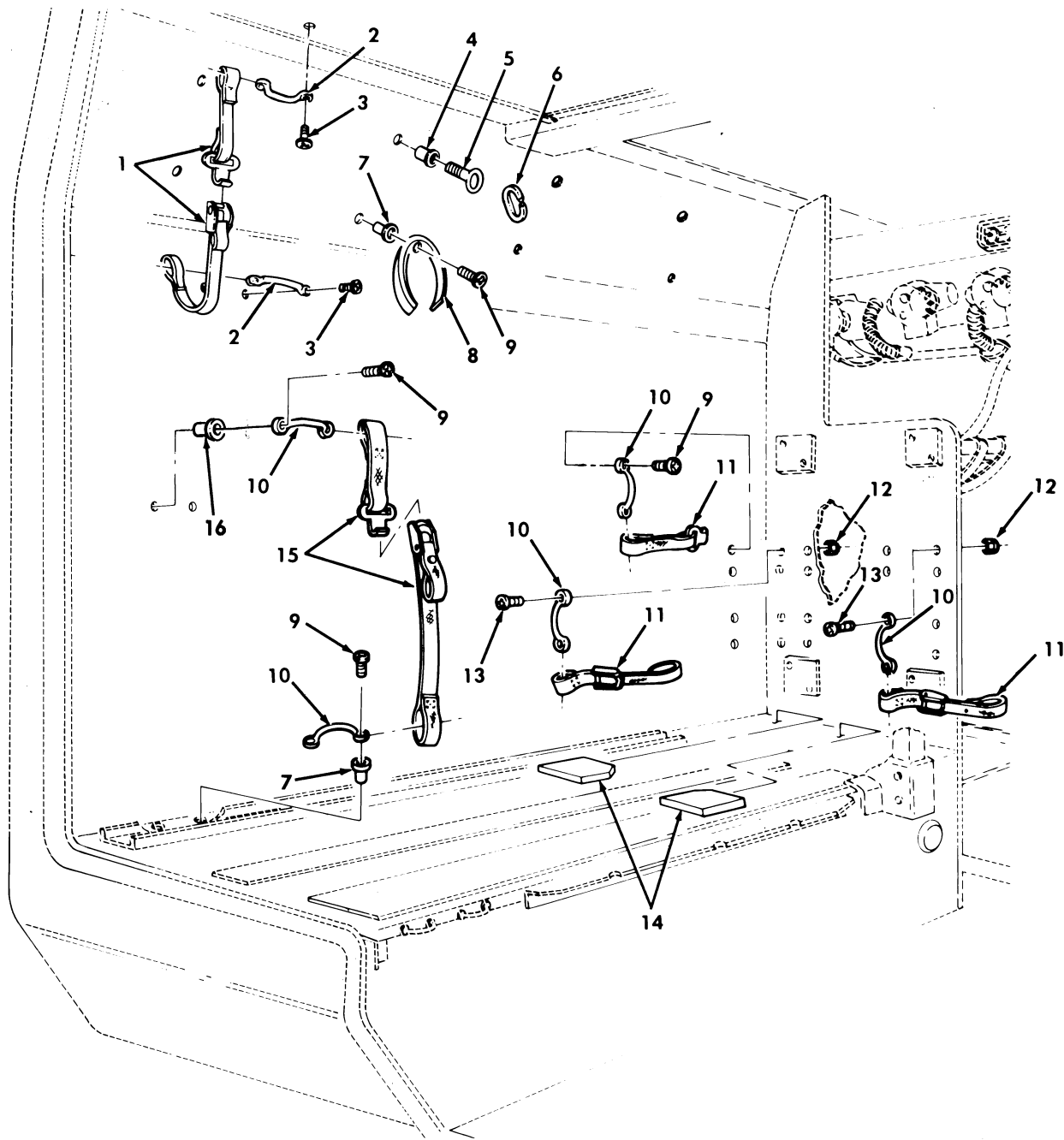

Figure 262. I.V. Bag Straps and Hooks, Oxygen Bottle Stowage, and Spine Board Strap Assemblies, M996, M996A1, M997, M997A1, and M997A2 Ambulance.



SECTION II			TM9-2320-280-24P			
(1)	(2)	(3)	(4)	(5)	(6)	(7)
ITEM	SMR			PART		
NO	CODE	NSN	CAGEC	NUMBER	DESCRIPTION AND USABLE ON CODES(UC)	QTY
					GROUP 1808 STOWAGE RACKS,BOXES, STRAPS,CARRYING CASES,CABLE REELS, HOSE REELS	
					FIG. 262 I.V. BAG STRAPS AND HOOKS, OXYGEN BOTTLE STOWAGE,AND SPINE BOARD STRAP ASSEMBLIES,M996,M996A1, M997,M997A1,AND M997A2 AMBULANCE	
1	PAOZZ	5340013971388	19207	12341385	STRAP,WEBBING.....	2
					UOC:A15,B15,B16,H15,H16	
2	PAOZZ	5340011918186	34623	5582608	HANDLE,BOW.....	4
					UOC:A15,B15,B16,H15,H16	
3	PAOZZ	5305012510728	34623	5592823	SCREW,MACHINE #10-32 X .75.....	8
					UOC:A15,B15,B16,H15,H16	
4	PAOZZ	5310004015321	96906	MS27130A32	NUT,PLAIN,BLIND RIV 1/4-20.....	8
					UOC:A15,B15,B16,H15,H16	
5	PAOZZ	5306012658767	34623	5588904	BOLT,EYE 1/4-20 X .75.....	8
					UOC:A15,B15,H15,H16	
6	PAOZZ	5340012658895	96508	760-2601	SNAP HOOK.....	8
					UOC:A15,B15,B16,H15,H16	
7	PAOZZ	5310001413062	96906	MS27130-A26	NUT,PLAIN,BLIND RIV #10-32.....	16
					UOC:A15,B15,B16,H15,H16	
8	PAOZZ	5340012658921	11153	0-130105-0012	STRAP,WEBBING.....	8
					UOC:A15,B15,B16,H15,H16	
9	PAOZZ	5305009953444	96906	MS35207-266	SCREW,MACHINE #10-32 X .75.....	20
					UOC:A15,B15,B16,H15,H16	
10	PAOZZ	5340011918186	34623	5582608	HANDLE,BOW.....	11
					UOC:A15,B15,B16,H15,H16	
11	PAOZZ	5340012658923	31272	44647-18	STRAP,WEBBING.....	4
					UOC:A15,B15,B16,H15,H16	
12	PAOZZ	5310012510726	34623	5593053	NUT,SELF-LOCKING,HE #10-32.....	6
					UOC:A15,B15,B16,H15,H16	
13	PAOZZ	5305000593660	96906	MS51958-64	SCREW,MACHINE #10-32 X 5/8.....	14
					UOC:A15,B15,B16,H15,H16	
14	PAOZZ	5340012775129	34623	SF5597714	BUMPER,NONMETALLIC.....	2
					UOC:A15,B15,B16,H15,H16	
15	PAOZZ	5340012876352	19207	12339817-9	STRAP,WEBBING.....	2
					UOC:A15,H15,H16	
16	PAOZZ	5310013953549	96906	MS27130-A28	NUT,PLAIN,BLIND RIV #10-32.....	4
					UOC:A15,B15,B16,H15,H16	

END OF FIGURE

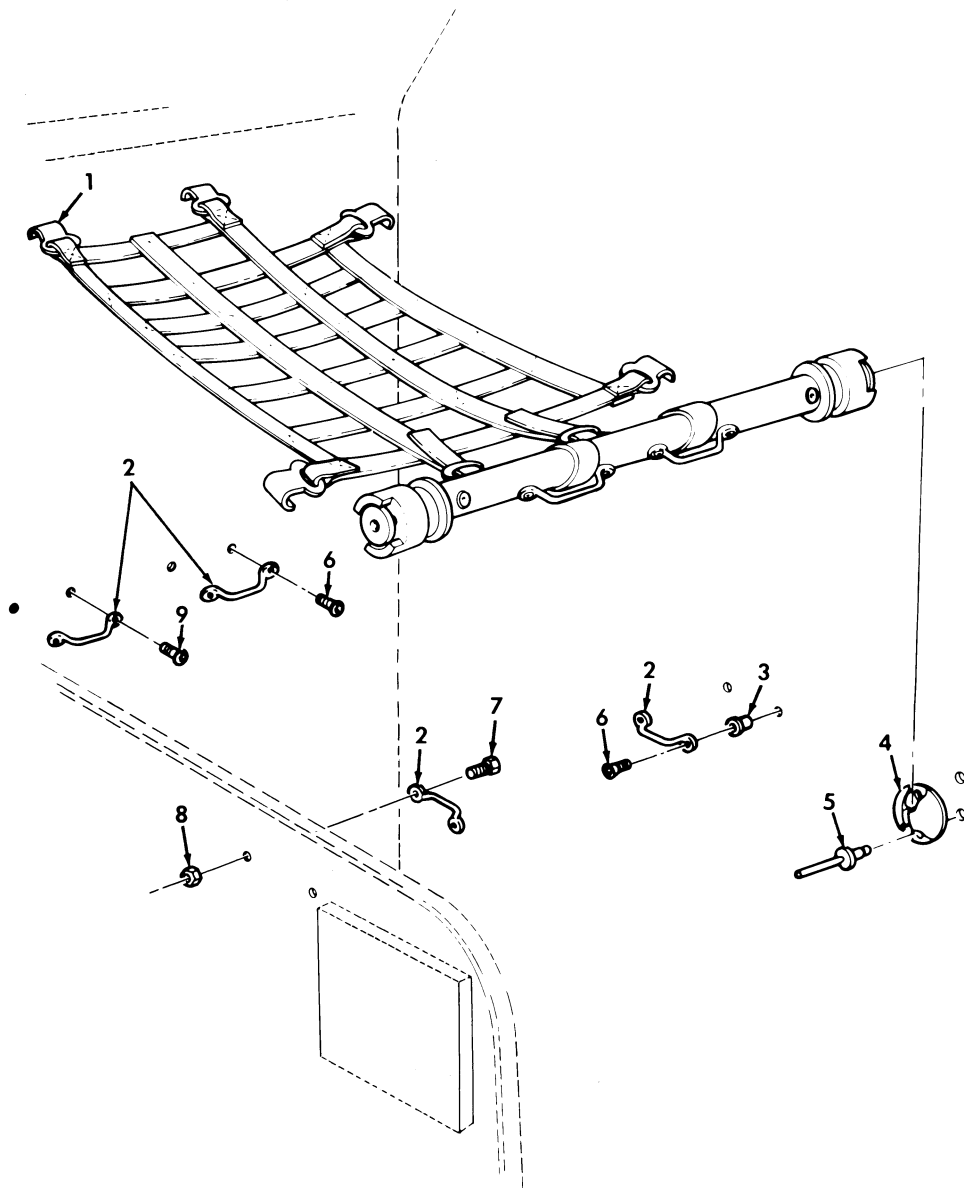

Figure 263. Web Shelf Net Assembly, M997, M997A1, and M997A2 Ambulance.

SECTION II			TM9-2320-280-24P			
(1)	(2)	(3)	(4)	(5)	(6)	(7)
ITEM	SMR			PART		
NO	CODE	NSN	CAGEC	NUMBER	DESCRIPTION AND USABLE ON CODES(UOC)	QTY
					GROUP 1808 STOWAGE RACKS,BOXES, STRAPS,CARRYING CASES,CABLE REELS, HOSE REELS	
					FIG. 263 WEB SHELF NET ASSEMBLY, M997,M997A1,AND M997A2 AMBULANCE	
1	PAOZZ	2540012715071	31272	45079-10	WEB SHELF,STOWAGE.....	1
					UOC:A15,B15,H15	
2	PAOZZ	5340011918186	34623	5582608	HANDLE,BOW.....	5
					UOC:A15,B15,H15	
3	PAOZZ	5310011981723	03481	S10P175	NUT,PLAIN,BLIND RIV #10-32 X 1.75..	4
					UOC:A15,B15,H15	
4	PFOZZ	2540012718010	31272	40000-10	ANCHOR PLATE,BOX.....	2
					UOC:A15,B15,H15	
5	PAOZZ	5320012596155	34623	5575936	RIVET,SOLID 3/16.....	4
					UOC:A15,B15,H15	
6	PAOZZ	5305012510728	34623	5592823	SCREW,MACHINE #10-32 X 3/4.....	6
					UOC:A15,B15,H15	
7	PAOZZ	5305001804966	96906	MS51849-64	SCREW,MACHINE #10-32 X .50.....	2
					UOC:A15,B15,H15	
8	PAOZZ	5310012510726	34623	5593053	NUT,SELF-LOCKING,HE #10-32.....	2
					UOC:A15,B15,H15	
9	PAOZZ	5305009953444	96906	MS35207-266	SCREW,MACHINE #10-32 X .88.....	2
					UOC:A15,B15,H15	

END OF FIGURE

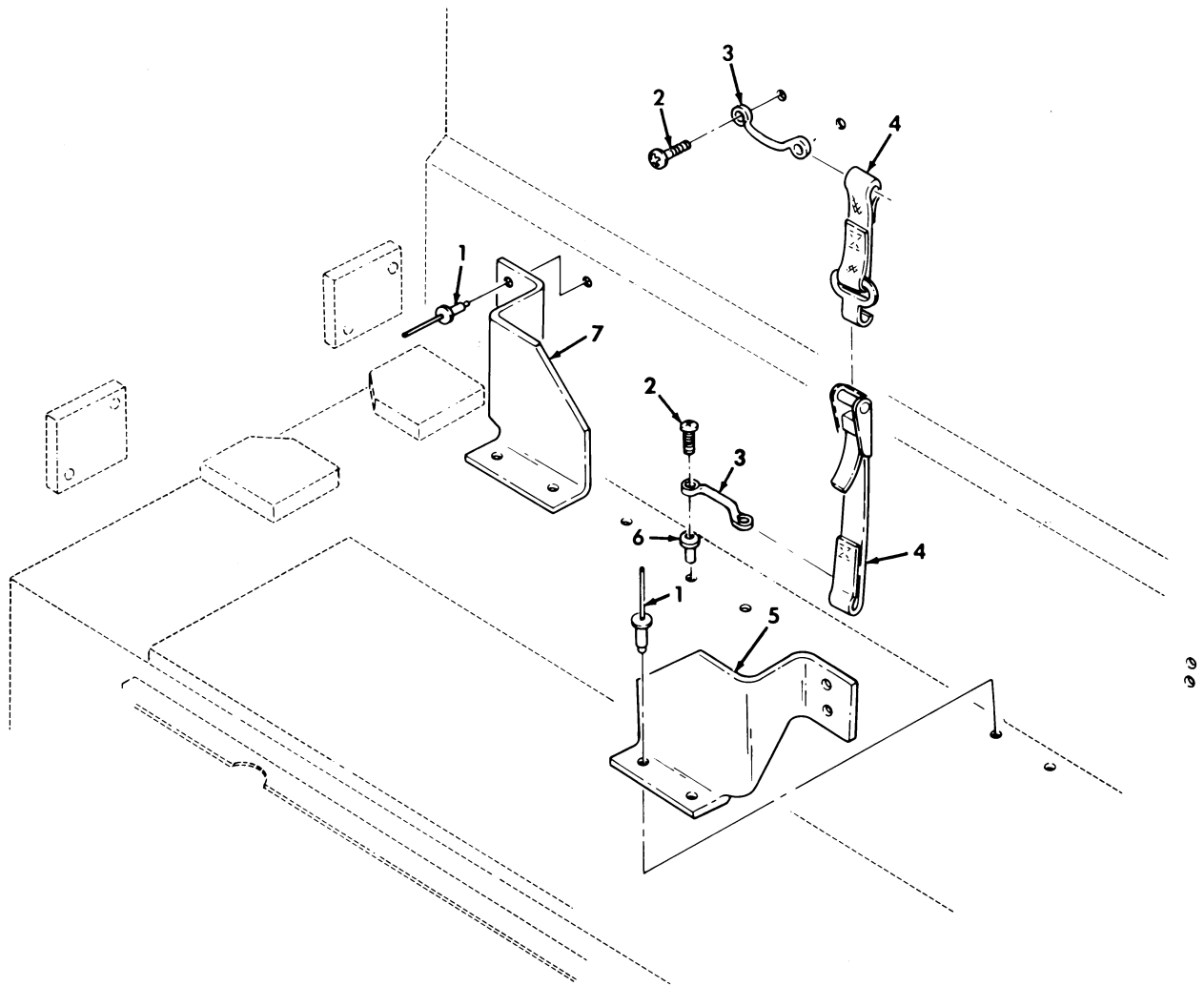

Figure 264. Attendant Seat Stowage Hardware, M996 and M996A1 Ambulance.

SECTION II			TM9-2320-280-24P			
(1)	(2)	(3)	(4)	(5)	(6)	(7)
ITEM	SMR			PART		
NO	CODE	NSN	CAGEC	NUMBER	DESCRIPTION AND USABLE ON CODES(UC)	QTY
					GROUP 1808 STOWAGE RACKS,BOXES, STRAPS,CARRYING CASES,CABLE REELS, HOSE REELS	
					FIG. 264 ATTENDENT SEAT STOWAGE HARDWARE,M996 AND M996A1 AMBULANCE	
1	PAOZZ	5320012645978	9K475	MGLP-B6-7	RIVET,BLIND 3/16.....	8
					UOC:B16,H16	
2	PAOZZ	5305012510728	34623	5592823	SCREW,MACHINE #10-32 X .75.....	4
					UOC:B16,H16	
2	PAOZZ	5305012510728	34623	5592823	SCREW,MACHINE #10-32 X .75.....	4
					UOC:A15,B15,H15	
3	PAOZZ	5340011918186	34623	5582608	HANDLE,BOW.....	2
					UOC:B16,H16	
4	PAOZZ	5340012728431	31272	44647-19	STRAP,WEBBING.....	1
					UOC:B16,H16	
5	PFOZZ	5340012726520	19207	12340990-1	BRACKET,DOUBLE ANGL.....	1
					UOC:B16,H16	
6	PAOZZ	5310011981723	03481	S10P175	NUT,PLAIN,BLIND RIV #10-32.....	2
					UOC:B16,H16	
7	PFOZZ	5340012708455	19207	12340990-2	BRACKET,DOUBLE ANGL.....	1
					UOC:B16,H16	

END OF FIGURE

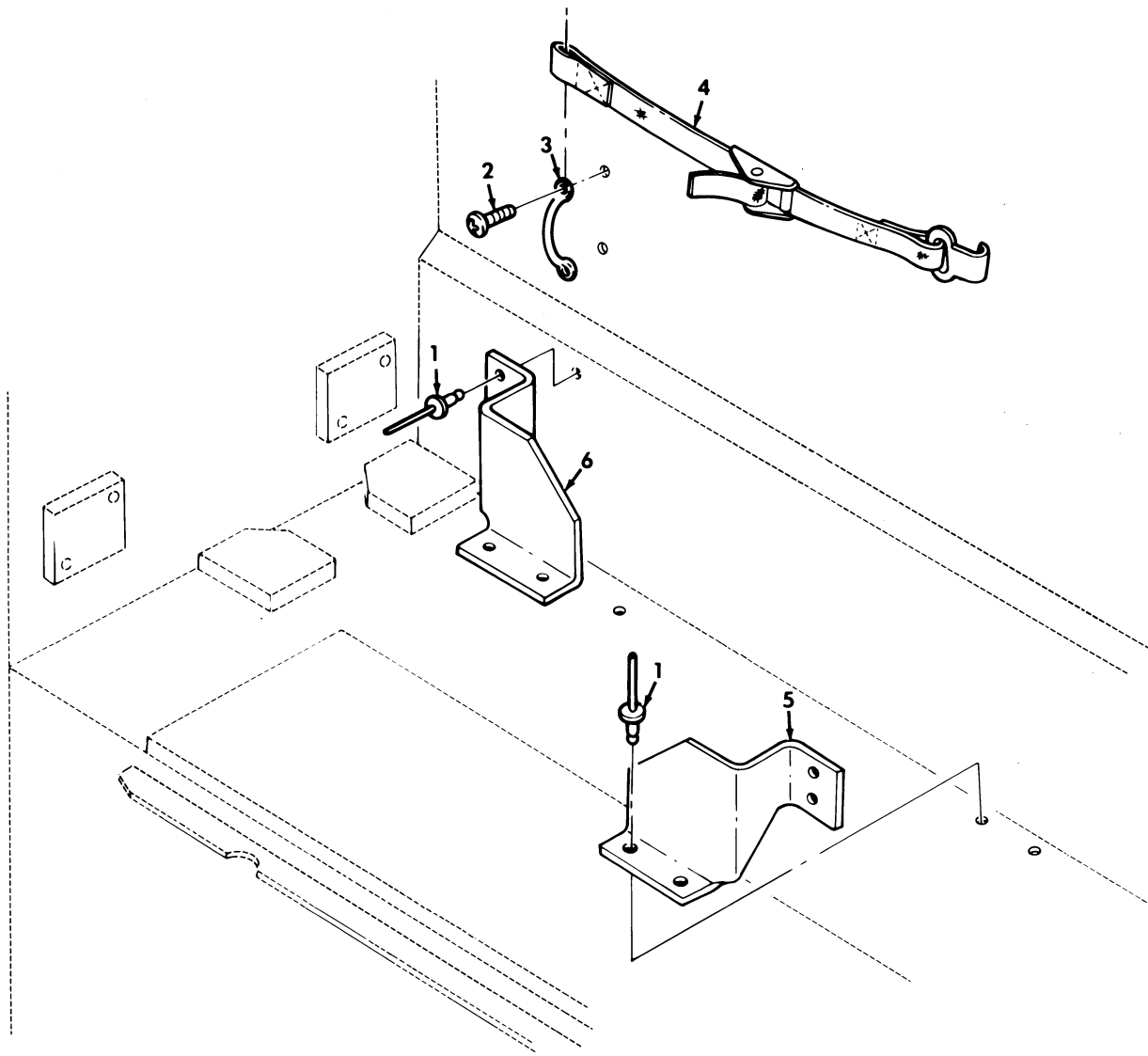
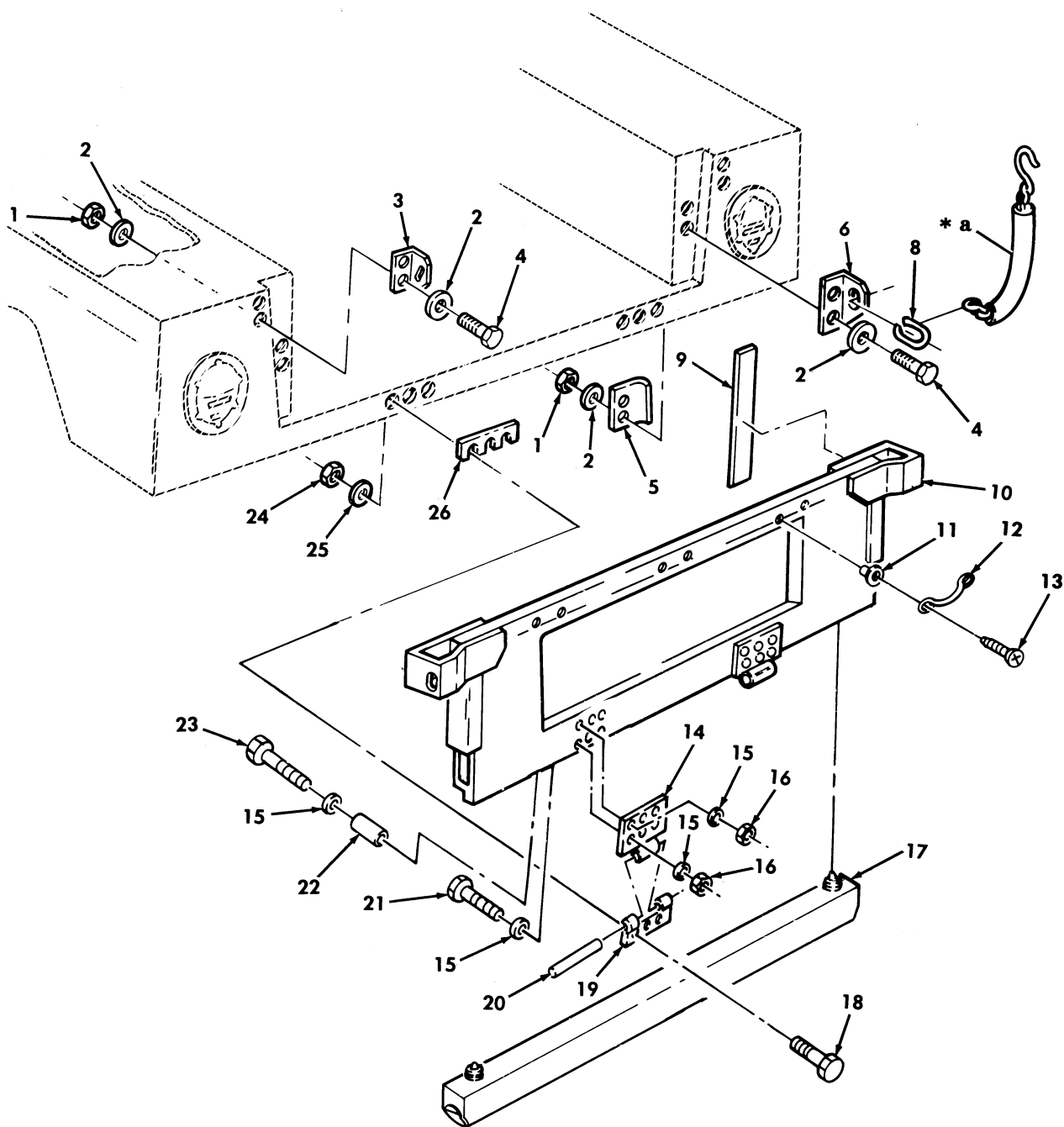

Figure 265. Attendant Seat Stowage Hardware, M997, M997A1, and M997A2 Ambulance.

SECTION II			TM9-2320-280-24P			
(1)	(2)	(3)	(4)	(5)	(6)	(7)
ITEM	SMR			PART		
NO	CODE	NSN	CAGEC	NUMBER	DESCRIPTION AND USABLE ON CODES(UOC)	QTY
					GROUP 1808 STOWAGE RACKS,BOXES, STRAPS,CARRYING CASES,CABLE REELS, HOSE REELS	
					FIG. 265 ATTENDENT SEAT STOWAGE HARDWARE,M997,M997A1,AND M997A2 AMBULANCE	
1	PAOZZ	5320012645978	9K475	MGLP-B6-7	RIVET,BLIND 3/16.....	8
					UOC:A15,B15,H15	
2	PAOZZ	5305012510728	34623	5592823	SCREW,MACHINE #10-32 X .75.....	4
					UOC:A15,B15,H15	
3	PAOZZ	5340011918186	34623	5582608	HANDLE,BOW.....	2
					UOC:A15,B15,H15	
4	PAOZZ	5340012822670	31272	45087-10	STRAP,WEBBING.....	1
					UOC:A15,B15,H15	
5	PFOZZ	5340012726520	19207	12340990-1	BRACKET,DOUBLE ANGL REAR,R.H.....	1
					UOC:A15,B15,H15	
6	PFOZZ	5340012708455	19207	12340990-2	BRACKET,DOUBLE ANGL REAR,L.H.....	1
					UOC:A15,B15,H15	

END OF FIGURE

7- 8



\* a PART OF ITEM 7

Figure 266. Tailgate Assembly and Related Parts.



SECTION II			TM9-2320-280-24P			
(1)	(2)	(3)	(4)	(5)	(6)	(7)
ITEM NO	SMR CODE	NSN	CAGEC	PART NUMBER	DESCRIPTION AND USABLE ON CODES(UC)	QTY
GROUP 1810 CARGO BODY						
FIG. 266 TAILGATE ASSEMBLY AND RELATED PARTS						
1	PAOZZ	5310008140673	96906	MS51943-33	NUT, SELF-LOCKING, HE 5/16-18..... UOC:AVY, A11, A13, A14, A20, A24, A25, A26, A27, BVY, B17, B18, B20, B24, B25, C17, HVY, H11, H13, H14, H17, H18, H20, H24, H25, H26, H27, MMM, NNN	8
2	PAOZZ	5310012520512	34623	5592832	WASHER, FLAT 5/16..... UOC:AVY, A11, A13, A14, A20, A24, A25, A26, A27, BVY, B17, B18, B20, B24, B25, C17, HVY, H11, H13, H14, H17, H18, H20, H24, H25, H26, H27, MMM, NNN	16
3	PFOZZ	5340012605792	19207	12338974-2	BRACKET, ANGLE R.H..... UOC:AVY, A11, A13, A14, A20, A24, A25, A26, A27, BVY, B17, B18, B20, B24, B25, C17, HVY, H11, H13, H14, H17, H18, H20, H24, H25, H26, H27, MMM, NNN	1
3	PFOZZ	5340012609874	34623	5596374	BRACKET, ANGLE L.H..... UOC:AVY, A11, A13, A14, A20, A24, A25, A26, A27, BVY, B17, B18, B20, B24, B25, C17, HVY, H11, H13, H14, H17, H18, H20, H24, H25, H26, H27, MMM, NNN	1
4	PAOZZ	5306000514077	80204	B1821BH031F113N	BOLT, MACHINE 5/16-18 X 1.125..... UOC:AVY, A11, A13, A14, A20, A24, A25, A26, A27, BVY, B17, B18, B20, B24, B25, C17, HVY, H11, H13, H14, H17, H18, H20, H24, H25, H26, H27, MMM, NNN	8
5	PFOZZ	5340011858724	34623	5575752	BRACKET, ANGLE..... UOC:AVY, A11, A13, A14, A20, A24, A25, A26, A27, BVY, B17, B18, B20, B24, B25, C17, HVY, H11, H13, H14, H17, H18, H20, H24, H25, H26, H27, MMM, NNN	2
6	PFOZZ	5340011861280	34623	5575702	BRACKET, ANGLE L.H..... UOC:AVY, A11, A13, A14, A20, A24, A25, A26, A27, BVY, B17, B18, B20, B24, B25, C17, HVY, H11, H13, H14, H17, H18, H20, H24, H25, H26, H27, MMM, NNN	1
6	PFOZZ	5340011861281	34623	5575703	BRACKET, ANGLE R.H..... UOC:AVY, A11, A13, A14, A20, A24, A25, A26, A27, BVY, B17, B18, B20, B24, B25, C17, HVY, H11, H13, H14, H17, H18, H20, H24, H25, H26, H27, MMM, NNN	1
7	PAOZZ	2510009332893	19207	12339227-1	COVER AND CHAIN L.H..... UOC:AVY, A11, A13, A14, A20, A24, A25, A26, A27, BVY, B17, B18, B20, B24, B25, C17, HVY, H11, H13, H14, H17, H18, H20, H24, H25, H26, H27, MMM, NNN	1
7	PFOZZ	2510009332895	19207	12339227-2	COVER AND CHAIN R.H..... UOC:AVY, A11, A13, A14, A20, A24, A25, A26, A27, BVY, B17, B18, B20, B24, B25, C17, HVY,	1

SECTION II			TM9-2320-280-24P			
(1)	(2)	(3)	(4)	(5)	(6)	(7)
ITEM NO	SMR CODE	NSN	CAGEC	PART NUMBER	DESCRIPTION AND USABLE ON CODES(UC)	QTY
8	PAOZZ	4010011948546	19207	12339223	H11,H13,H14,H17,H18,H20,H24,H25,H26, H27,MMM,NNN .LINK,CHAIN,LAP.....	1
9	PFOZZ	5330011932338	19207	12339228-9	UOC:AVY,A11,A13,A14,A20,A24,A25,A26, A27,BVY,B17,B18,B20,B24,B25,C17,HVY, H11,H13,H14,H17,H18,H20,H24,H25,H26, H27,MMM,NNN RUBBER STRIP.....	2
10	PAOFF	2510011739316	19207	12338981-1	UOC:AVY,A11,A13,A14,A20,A24,A25,A26, A27,BVY,B17,B18,B20,B24,B25,C17,HVY, H11,H13,H14,H17,H18,H20,H24,H25,H26, H27,MMM,NNN TAILGATE,VEHICLE BO.....	1
11	PAOZZ	5310011981723	19207	12339998-14	UOC:AVY,A11,A13,A14,A20,A24,A25,A26, A27,BVY,B17,B18,B20,B24,B25,C17,HVY, H11,H13,H14,H17,H18,H20,H24,H25,H26, H27,MMM,NNN NUT,PLAIN,BLIND RIV #10-32.....	6
12	PAOZZ	5340011978673	19207	12338839-4	UOC:AVY,A11,A13,A14,A20,A24,A25,A26, A27,BVY,B17,B18,B20,B24,B25,C17,HVY, H11,H13,H14,H17,H18,H20,H24,H25,H26, H27,MMM,NNN HANDLE,BOW.....	3
13	PAOZZ	5305011993371	16941	PL25J02P12	UOC:AVY,A11,A13,A14,A20,A24,A25,A26, A27,BVY,B17,B18,B20,B24,B25,C17,HVY, H11,H13,H14,H17,H18,H20,H24,H25,H26, H27,MMM,NNN SCREW,CAP,SOCKET HE SELF-LOCKING #10-32 X 1.75.....	6
14	PAOZZ	5340013672070	19207	12339945	UOC:AVY,A11,A13,A14,A20,A24,A25,A26, A27,BVY,B17,B18,B20,B24,B25,C17,HVY, H11,H13,H14,H17,H18,H20,H24,H25,H26, H27,MMM,NNN HINGE,BUTT PART OF KIT P/N 57K0107.	2
15	PAOZZ	5310008093078	96906	MS27183-11	UOC:AVY,A11,A13,A14,A20,A24,A25,A26, A27,BVY,B17,B18,B20,B24,B25,C17,HVY, H11,H13,H14,H17,H18,H20,H24,H25,H26, H27,MMM,NNN WASHER,FLAT 1/4 PART OF KIT OF KIT 57K0107.....	12
16	PAOZZ	5310010666759	72962	21NE-040	UOC:AVY,A11,A13,A14,A20,A24,A25,A26, A27,BVY,B17,B18,B20,B24,B25,C17,HVY, H11,H13,H14,H17,H18,H20,H24,H25,H26, H27,MMM,NNN NUT,SELF-LOCKING,HE 1/4-20 PART OF KIT P/N 57K0107.....	6
17	PAOZZ	5340012598579	34623	5596736	UOC:AVY,A11,A13,A14,A20,A24,A25,A26, A27,BVY,B17,B18,B20,B24,B25,C17,HVY, H11,H13,H14,H17,H18,H20,H24,H25,H26, H27,MMM,NNN BUMPER,NONMETALLIC.....	1

SECTION II			TM9-2320-280-24P			
(1)	(2)	(3)	(4)	(5)	(6)	(7)
ITEM	SMR			PART		
NO	CODE	NSN	CAGEC	NUMBER	DESCRIPTION AND USABLE ON CODES(UC)	QTY
18	PAOZZ	5305000680511	80204	B1821BH038C125N	H11, H13, H14, H17, H18, H20, H24, H25, H26, H27, MMM, NNN SCREW, CAP, HEXAGON H 3/8-16 X 1.25.. UOC:AVY, A11, A13, A14, A20, A24, A25, A26, A27, BVY, B17, B18, B20, B24, B25, C17, HVY, H11, H13, H14, H17, H18, H20, H24, H25, H26, H27, MMM, NNN	6
19	PAOZZ	5340011897739	34623	12339999	LEAF, BUTT HINGE..... UOC:AVY, A11, A13, A14, A20, A24, A25, A26, A27, BVY, B17, B18, B20, B24, B25, C17, HVY, H11, H13, H14, H17, H18, H20, H24, H25, H26, H27, MMM, NNN	2
20	PAOZZ	5315011905908	19207	12339663	PIN, SPRINGHINGE TAI PART OF KIT P/N 57K0107..... UOC:AVY, A11, A13, A14, A20, A24, A25, A26, A27, BVY, B17, B18, B20, B24, B25, C17, HVY, H11, H13, H14, H17, H18, H20, H24, H25, H26, H27, MMM, NNN	2
21	PAOZZ	5305002253843	80204	B1821BH025C100N	SCREW, CAP, HEXAGON H 1/4-20 X 1.00 PART OF KIT P/N 57K0107..... UOC:AVY, A11, A13, A14, A20, A24, A25, A26, A27, BVY, B17, B18, B20, B24, B25, C17, HVY, H11, H13, H14, H17, H18, H20, H24, H25, H26, H27, MMM, NNN	3
22	PAOZZ	5365014130275	19207	12338521-1	SPACER, SLEEVE PART OF KIT P/N 57K0107..... UOC:AVY, A11, A13, A14, A20, A24, A25, A26, A27, BVY, B17, B18, B20, B24, B25, C17, HVY, H11, H13, H14, H17, H18, H20, H24, H25, H26, H27, MMM, NNN	3
23	PAOZZ	5305000712236	96906	MS90725-15	SCREW, CAP, HEXAGON H 1/4-20 X 2.25 PART OF KIT P/N 57K0107..... UOC:AVY, A11, A13, A14, A20, A24, A25, A26, A27, BVY, B17, B18, B20, B24, B25, C17, HVY, H11, H13, H14, H17, H18, H20, H24, H25, H26, H27, MMM, NNN	3
24	PAOZZ	5310009359021	96906	MS51943-35	NUT, SELF-LOCKING, HE 3/8-16..... UOC:AVY, A11, A13, A14, A20, A24, A25, A26, A27, BVY, B17, B18, B20, B24, B25, C17, HVY, H11, H13, H14, H17, H18, H20, H24, H25, H26, H27, MMM, NNN	6
25	PAOZZ	5310000806004	96906	MS27183-14	WASHER, FLAT 3/8..... UOC:AVY, A11, A13, A14, A20, A24, A25, A26, A27, BVY, B17, B18, B20, B24, B25, C17, HVY, H11, H13, H14, H17, H18, H20, H24, H25, H26, H27, MMM, NNN	6
26	PAOZZ	5365012712491	19207	12340045	SPACER, PLATE..... UOC:AVY, A11, A13, A14, A20, A24, A25, A26, A27, BVY, B17, B18, B20, B24, B25, C17, HVY, H11, H13, H14, H17, H18, H20, H24, H25, H26, H27, MMM, NNN	2

END OF FIGURE

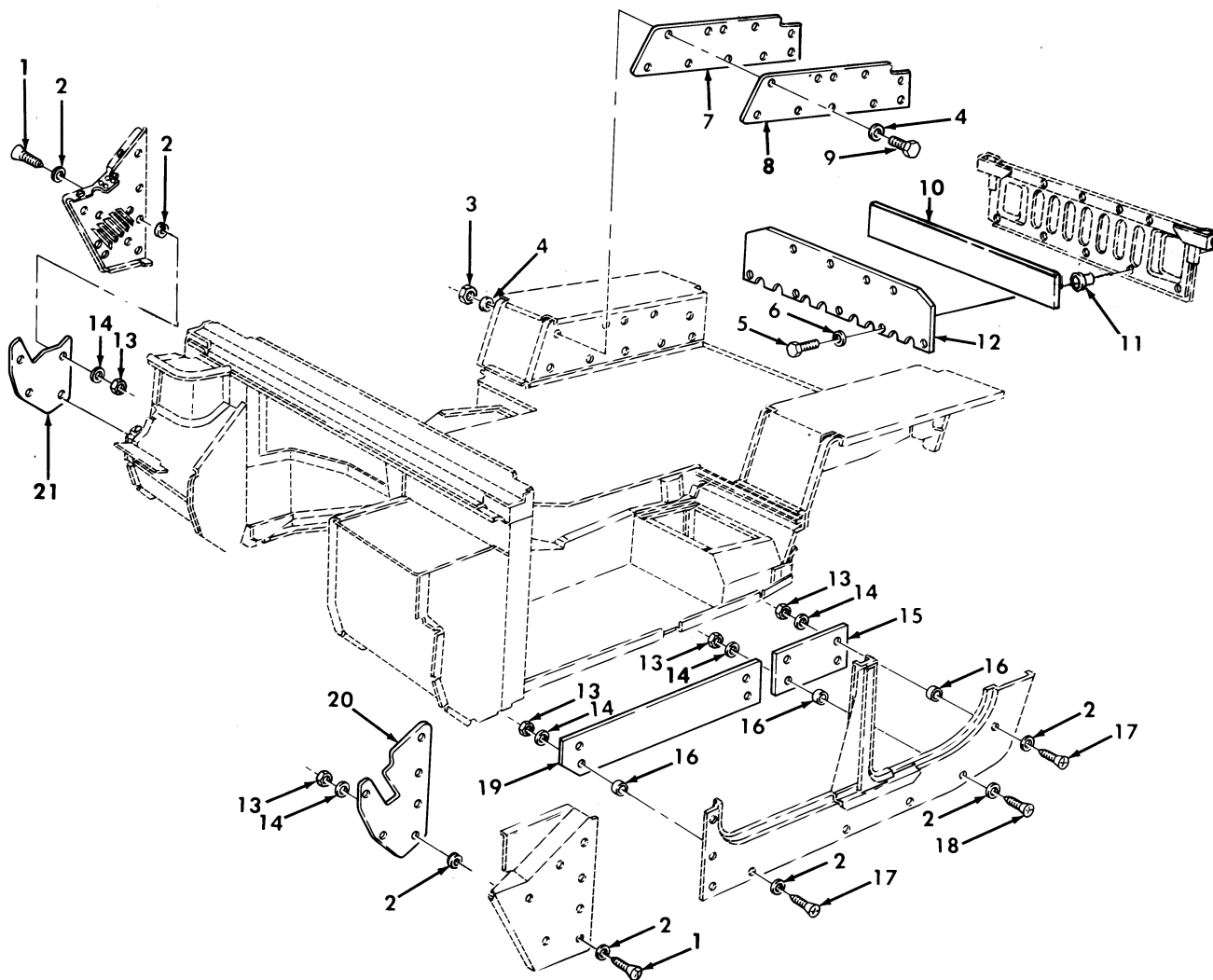

Figure 267. Body Armor Panels and Mounting Hardware.

SECTION II			TM9-2320-280-24P			
(1)	(2)	(3)	(4)	(5)	(6)	(7)
ITEM	SMR			PART		
NO	CODE	NSN	CAGEC	NUMBER	DESCRIPTION AND USABLE ON CODES(UOC)	QTY
GROUP 1812 SPECIAL PURPOSE BODIES						
FIG. 267 BODY ARMOR PANELS AND MOUNTING HARDWARE						
1	PAOZZ	5305009881725	96906	MS35206-281	SCREW,MACHINE 1/4-20 X .75.....	11
					UOC:A11,A15,A24,A25,A26,A27,B16,B17, B18,B24,B25,C17,H11,H15,H16,H17,H18, H24,H25,H26,H27,MMM	
2	PAOZZ	5310008094058	96906	MS27183-10	WASHER,FLAT 1/4.....	38
					UOC:A11,A15,A24,A25,A26,A27,B16,B17, B18,B24,B25,C17,H11,H15,H16,H17,H18, H24,H25,H26,H27,MMM	
3	PAOZZ	5310000614650	96906	MS51943-31	NUT,SELF-LOCKING,HE 1/4-20.....	20
					UOC:A11,A15,A24,A25,A26,A27,B16,B17, B18,B24,H11,H15,H16,H17,H18,H24,H25, H26,H27,MMM	
3	PAOZZ	5310000614650	96906	MS51943-31	NUT,SELF-LOCKING,HE 1/4-20.....	18
					UOC:B25,C17	
4	PAOZZ	5310008094058	96906	MS27183-10	WASHER,FLAT 1/4.....	36
					UOC:B25,C17	
4	PAOZZ	5310008094058	96906	MS27183-10	WASHER,FLAT 1/4.....	40
					UOC:A11,A15,A24,A25,A26,A27,B16,B17, B18,B24,H11,H15,H16,H17,H18,H24,H25, H26,H27,MMM	
5	PAOZZ	5305002253843	80204	B1821BH025C100N	SCREW,CAP,HEXAGON H 1/4-20 X 1.00..	9
					UOC:A11,A24,A25,A26,A27,B17,B18,B24, B25,C17,H11,H17,H18,H24,H25,H26,H27, MMM	
6	PAOZZ	5310005825965	96906	MS35338-44	WASHER,LOCK 1/4.....	9
					UOC:A11,A24,A25,A26,A27,B17,B18,B24, B25,C17,H11,H17,H18,H24,H25,H26,H27, MMM	
7	PFOZZ	2540011929716	34623	12339029-1	DAMPENER,SOUND,VEHI.....	2
					UOC:A24,A25,A26,A27,B17,B18,B24,B25, C17,H17,H18,H24,H25	
8	PFOZZ	9515011853111	19207	12339028-1	ARMOR PLATE.....	2
					UOC:B17,B18,H17,H18	
8	PFOZZ	2510014133618	19207	12446913-2	LINER,VEHICULAR FEN.....	2
					UOC:B25	
8	PFOZZ	2510014110653	19207	12446913-1	LINER,VEHICULAR FEN.....	2
					UOC:C17	
8	PFOZZ	9515011899732	34623	5578331	ARMOR PLATE.....	2
					UOC:A24,A25,A26,A27,B24,H24,H25,H26, H27	
9	PAOZZ	5305000680502	96906	MS90725-6	SCREW,CAP,HEXAGON H 1/4-20 X 3/4...	20
					UOC:A24,A25,A26,A27,B17,B18,B24,H17, H18,H24,H25,H26,H27	
9	PAOZZ	5305000680502	96906	MS90725-6	SCREW,CAP,HEXAGON H 1/4-20 X 3/4...	20
					UOC:B25,C17	
10	PFOZZ	2540011925948	34623	12339029-2	DAMPENER,SOUND,TAIL.....	1
					UOC:A11,A24,A25,A26,A27,B17,B18,B25, C17,H11,H17,H18,H24,H25,H26,H27,MMM	

SECTION II			TM9-2320-280-24P			
(1)	(2)	(3)	(4)	(5)	(6)	(7)
ITEM	SMR			PART		
NO	CODE	NSN	CAGEC	NUMBER	DESCRIPTION AND USABLE ON CODES(UOC)	QTY
11	PAOZZ	4931012028692	19207	12339998-13	PLUSNUT 1/4-20..... UOC:A11,A24,A25,A26,A27,B17,B18,B24, B25,C17,H11,H17,H18,H24,H25,H26,H27, MMM	9
12	PFOZZ	9515011899721	19207	12339232-1	ARMOR PLATE..... UOC:A11,B17,B18,C17,H11,H17,H18,MMM	1
12	PFOZZ	9515011899721	19207	12339232-2	ARMOR PLATE..... UOC:A24,A25,A26,A27,B24,B25,H24,H25, H26,H27	1
13	PAOZZ	5310000614650	96906	MS51943-31	NUT,SELF-LOCKING,HE 1/4-20..... UOC:A11,A15,A24,A25,A26,A27,B16,B17, B18,B24,B25,C17,H11,H15,H16,H17,H18, H24,H25,H26,H27,MMM	27
14	PAOZZ	5310011023270	24617	2436161	WASHER,FLAT 1/4..... UOC:A11,A15,A24,A25,A26,A27,B16,B17, B18,B24,B25,C17,H11,H15,H16,H17,H18, H24,H25,H26,H27,MMM	27
15	PFOZZ	9515011853109	34623	5579295	ARMOR PLATE..... UOC:A11,A15,B16,B17,B18,C17,H11,H15, H16,H17,H18,MMM	2
15	PFOZZ	9515011899731	34623	5579296	ARMOR PLATE..... UOC:A24,A25,A26,A27,B24,B25,H24,H25, H26,H27	2
16	PFOZZ	5365011940761	34623	5579297	SPACER,SLEEVE..... UOC:A11,A15,A24,A25,A26,A27,B16,B17, B18,B24,B25,C17,H11,H15,H16,H17,H18, H24,H25,H26,H27,MMM	16
17	PAOZZ	5305009881170	96906	MS35206-284	SCREW,MACHINE 1/4-20 X 1.25..... UOC:A11,A15,B15,B16,B17,B18,C17,H11, H15,H16,H17,H18,MMM	12
17	PAOZZ	5305009881170	96906	MS35206-284	SCREW,MACHINE 1/4-20 X 1.25..... UOC:A24,A25,A26,A27,B24,B25,H24,H25, H26,H27	16
18	PAOZZ	5305000711318	96906	MS51957-83	SCREW,MACHINE 1/4-20 X 1.25..... UOC:A11,A15,B15,B16,B17,B18,C17,H11, H15,H16,H17,H18,MMM	4
19	PFOZZ	5340011963297	19207	12340688-1	PLATE,MENDING R.H..... UOC:A11,A15,B16,B17,B18,C17,H11,H15, H16,H17,H18,MMM	1
19	PFOZZ	9515011853110	19207	12340689-1	ARMOR PLATE..... UOC:A11,A15,B16,B17,B18,C17,H11,H15, H16,H17,H18,MMM	1
19	PFOZZ	9515011899745	34623	5579292	ARMOR PLATE..... UOC:A24,A25,A26,A27,B24,B25,H24,H25, H26,H27	1
19	PFOZZ	9515011899746	19207	12340689-2	ARMOR PLATE L.H..... UOC:A24,A25,A26,A27,B24,B25,H24,H25, H26,H27	1
20	PFOZZ	9515011853119	34623	5574879	ARMOR PLATE..... UOC:A11,A15,B16,B17,B18,C17,H11,H15, H16,H17,H18,MMM	1
20	PFOZZ	9515011899733	19207	12340694-2	ARMOR PLATE..... UOC:A24,A25,A26,A27,B24,B25,H24,H25,	1

SECTION II			TM9-2320-280-24P			
(1)	(2)	(3)	(4)	(5)	(6)	(7)
ITEM	SMR			PART		
NO	CODE	NSN	CAGEC	NUMBER	DESCRIPTION AND USABLE ON CODES(UC)	QTY
21	PFOZZ	9515011863111	19207	12340693-1	H26,H27 ARMOR PLATE R.H..... UOC:A11,A15,B16,B17,B18,C17,H11,H15, H16,H18,MMM	1
21	PAOZZ	9515011899722	19207	12340693-2	ARMOR PLATE R.H..... UOC:A24,A25,A26,A27,B24,B25,H24,H25, H26,H27	1

END OF FIGURE

30 — 31  
thru  
38

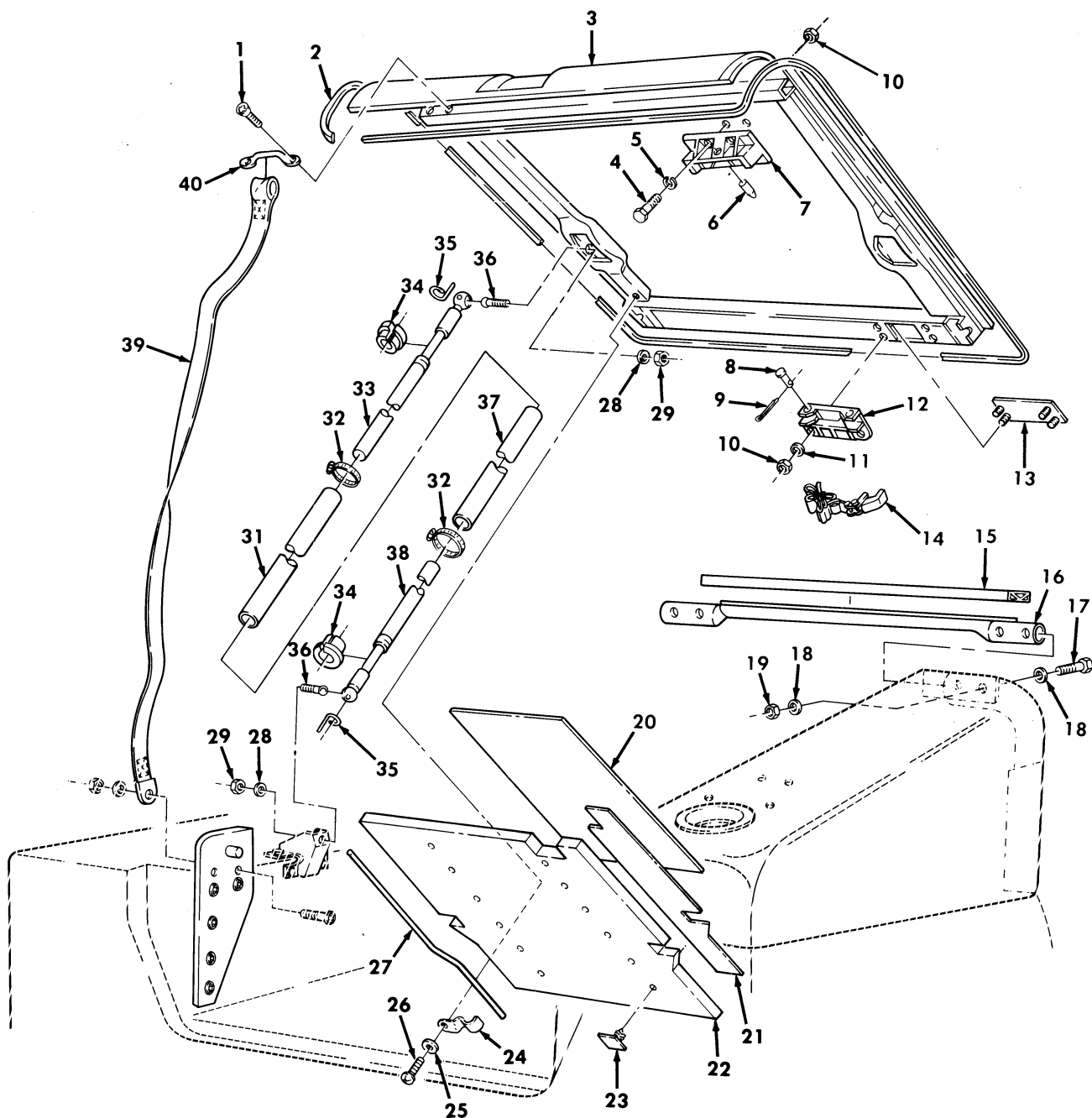

Figure 268. Cargo Shell Door, Insulation, Intermediate Pillar, Gas Spring, and Related Components.



SECTION II			TM9-2320-280-24P			
(1)	(2)	(3)	(4)	(5)	(6)	(7)
ITEM NO	SMR CODE	NSN	CAGEC	PART NUMBER	DESCRIPTION AND USABLE ON CODES(UOC)	QTY
GROUP 1812 SPECIAL PURPOSE BODIES						
FIG. 268 CARGO SHELL DOOR, INSULATION, INTERMEDIATE PILLAR, GAS SPRING, AND RELATED COMPONENTS						
1	PAOZZ	5305012542459	34623	5593313	SCREW, ASSEMBLED WAS #10-32 X 3/4... UOC:A11, A24, A25, A26, A27, B17, B18, B24, B25, C17, H11, H17, H18, H24, H25, H26, H27, MMM	2
2	PAOZZ	5330011959083	34623	12339595	SEAL, NONMETALLIC SP..... UOC:A11, A24, A25, A26, A27, B17, B18, B24, B25, C17, H11, H17, H18, H24, H25, H26, H27, MMM	1
3	PFOFF	2510012629520	34623	12339651-1	DOOR, HATCH, VEHICLE..... UOC:A11, H11, MMM	1
3	PFOFF	2510011853155	34623	12339651-2	DOOR, HATCH, VEHICLE..... UOC:B17, B18, H17, H18	1
3	PFOFF	2510014567889	19207	12446907	DOOR, HATCH, VEHICLE BASIC ARMOR..... UOC:C17	1
3	PFOFF	2510014762171	19207	12446911	DOOR, HATCH, VEHICLE SUPPLEMENTAL ARMOR..... UOC:B25	1
3	PFOFF	2510012489557	19207	12339641-2	DOOR, HATCH, VEHICLE SUPPLEMENTAL ARMOR..... UOC:A24, A27, B24, H24, H27	1
3	PFOFF	2510012507786	19207	12339641-1	DOOR, HATCH, VEHICLE SUPPLEMENTAL ARMOR..... UOC:A25, A26, H25, H26	1
4	PAOZZ	5306002258499	96906	MS90725-34	BOLT, MACHINE 5/16-18 X 1.00..... UOC:A11, A24, A27, B24, H11, H24, H27, MMM	4
5	PAOZZ	5310004079566	96906	MS35338-45	WASHER, LOCK 5/16..... UOC:A11, A24, A27, B24, H11, H24, H27, MMM	4
6	PAOZZ	5315002555580	18876	10189683	PIN, SHOULDER, HEADLE..... UOC:A11, A24, A27, B24, H11, H24, H27, MMM	1
7	PFOZZ	5340011972717	19207	10192299	BRACKET, MOUNTING..... UOC:A11, A24, A27, B24, H11, H24, H27, MMM	1
8	PAOZZ	5315009837402	96906	MS20392-4C69	PIN, STRAIGHT, HEADED..... UOC:A11, A24, A27, B24, H11, H24, H27, MMM	2
9	PAOZZ	5315002341861	80205	MS24665-298	PIN, COTTER..... UOC:A11, A24, A27, B24, H11, H24, H27, MMM	2
10	PAOZZ	5310008140673	96906	MS51943-33	NUT, SELF-LOCKING, HE 5/16-18..... UOC:A11, A24, A27, B24, H11, H24, H27, MMM	8
11	PAOZZ	5310012520512	34623	5592832	WASHER, FLAT 5/16..... UOC:A11, A24, A27, B24, H11, H24, H27, MMM	4
12	PFOZZ	5340011971444	19207	10192302	BRACKET, MOUNTING FRONT..... UOC:A11, A24, A27, B24, H11, H24, H27, MMM	1
13	PFOZZ	2540012102749	34623	5583291	PLATE, MOUNTING, LAUN..... UOC:A11, A24, A27, B24, H11, H24, H27, MMM	1
14	PAOZZ	5340011991662	31272	45053-10	STRAP, WEBBING..... UOC:A11, A24, A27, B24, H11, H24, H27, MMM	1
15	PAFZZ	5330011978298	06968	ORD-112	SEAL..... UOC:B24, B25, C17, H11, H17, H18, H24, H25,	1

SECTION II			TM9-2320-280-24P			
(1)	(2)	(3)	(4)	(5)	(6)	(7)
ITEM	SMR			PART		
NO	CODE	NSN	CAGEC	NUMBER	DESCRIPTION AND USABLE ON CODES(UOC)	QTY
16	PFFZZ	2510011899741	19207	12339612	H26,H27,MMM FRAME SECTION,STRUC.....	1
					UOC:B24,B25,C17,H11,H17,H18,H24,H25, H26,H27,MMM	
17	PAFZZ	5305008465703	80204	B1821BH038C300N	SCREW,CAP,HEXAGON H 3/8-16 X 3.00..	4
					UOC:B17,B24,B25,C17,H11,H17,H18,H24, H25,H26,H27,MMM	
18	PAFZZ	5310000877493	96906	MS27183-13	WASHER,FLAT 3/8.....	8
					UOC:B17,B24,B25,C17,H11,H17,H18,H24, H25,H26,H27,MMM	
19	PAFZZ	5310009359021	96906	MS51943-35	NUT,SELF-LOCKING,HE 3/8-16.....	4
					UOC:B17,B24,B25,C17,H11,H17,H18,H24, H25,H26,H27,MMM	
20	PAOZZ	2510012491580	19207	12339650	INSULATION PANEL,VE.....	1
					UOC:B17,C17,H11,H17,H18,MMM	
21	PAOZZ	2510012491581	19207	12339649-2	DAMPNER,SOUND,DOOR R.H.....	1
					UOC:B17,C17,H11,H17,H18,MMM	
21	PAOZZ	2510012491582	19207	12339649-1	INSULATION PANEL,VE L.H.....	1
					UOC:B17,C17,H11,H17,H18,MMM	
22	PAOZZ	2510012491583	19207	12339625	LINER,DOOR,CARGO.....	1
					UOC:B17,C17,H11,H17,H18,MMM	
23	PAOZZ	5325012570801	02768	M36-0790-10	FASTENER,SPRING TEN.....	12
					UOC:B17,C17,H11,H17,H18,MMM	
24	PAOZZ	5340012604881	34623	5591114	CLIP,SPRING TENSION.....	10
					UOC:B17,C17,H11,H17,H18,MMM	
25	PAOZZ	5310000145850	96906	MS27183-42	WASHER,FLAT #10.....	10
					UOC:B17,C17,H11,H17,H18,MMM	
26	PAOZZ	5305000457603	80205	MS24625-42	SCREW,TAPPING.....	10
					UOC:B17,C17,H11,H17,H18,MMM	
27	PAOZZ	4710012513076	34623	5591115	TUBE,BENT,METALLIC.....	2
					UOC:B17,C17,H11,H17,H18,MMM	
28	PAOZZ	5310012520512	34623	5592832	WASHER,FLAT 5/16.....	4
					UOC:A11,A24,A25,A26,A27,B17,B18,B24, B25,C17,H11,H17,H18,H24,H25,H26,H27, MMM	
29	PAOZZ	5310008140673	96906	MS51943-33	NUT,SELF-LOCKING,HE 5/16-18.....	4
					UOC:A11,A24,A25,A26,A27,B17,B18,B24, B25,C17,H11,H17,H18,H24,H25,H26,H27, MMM	
30	PAOOO	2590012121057	19207	12340832-3	PARTS KIT,DOOR LIFT.....	2
					UOC:A11,B17,B18,C17,H11,H17,H18,MMM	
30	PAOOO	2590012106202	19207	12340832-4	GAS SPRING,DOOR,VEH.....	2
					UOC:A24,A25,A26,A27,B24,B25,H24,H25, H26,H27	
31	PFOZZ	4710011927965	34623	5579895	.TUBE,METALLIC.....	1
					UOC:A11,A24,A25,A26,A27,B17,B18,B24, B25,C17,H11,H17,H18,H24,H25,H26,H27, MMM	
32	PAOZZ	4730009083194	76599	H12SS	.CLAMP,HOSE.....	2
					UOC:A11,A24,A25,A26,A27,B17,B18,B24, B25,C17,H11,H17,H18,H24,H25,H26,H27, MMM	
33	PAOZZ	5340012187739	19207	12340041-4	.CLOSER,DOOR BASIC ARMOR.....	2

SECTION II			TM9-2320-280-24P			
(1)	(2)	(3)	(4)	(5)	(6)	(7)
ITEM	SMR			PART		
NO	CODE	NSN	CAGEC	NUMBER	DESCRIPTION AND USABLE ON CODES(UC)	QTY
33	PAOZZ	5360011885083	55787	F2824	UOC:A11,B17,B18,C17,H11,H17,H18,MMM .SPRING,GAS,VEHICULA SUPPLEMENTAL ARMOR.....	2
34	PFOZZ	3120012004105	19207	12339602	UOC:A24,A25,A26,A27,B24,B25,H24,H25, H26,H27 .BUSHING HALF,SLEEVE.....	2
35	PAOZZ	5325011354290	55787	012351	UOC:B17,B24,B25,C17,H11,H17,H18,H24, H25,H26,H27,MMM .RING,RETAINING.....	2
36	PAOZZ	5307011406594	55787	393835	UOC:A11,A24,A25,A26,A27,B17,B18,B24, B25,C17,H11,H17,H18,H24,H25,H26,H27, MMM .STUD,BALL.....	2
37	PFOZZ	4710011929546	34623	5579894	UOC:A11,A24,A25,A26,A27,B17,B18,B24, B25,C17,H11,H17,H18,H24,H25,H26,H27, MMM .TUBE,METALLIC.....	1
38	PAOZZ	5340012362112	55787	F2802	UOC:A11,B17,B18,C17,H11,H17,H18,MMM .CLOSER,DOOR.....	1
38	PAOZZ	5340011887393	55787	F2823	UOC:A11,B17,B18,C17,H11,H17,H18,MMM .CLOSER,DOOR.....	1
39	PAOZZ	5340011976753	31272	44884	UOC:A24,A25,A26,A27,B24,B25,H24,H25, H26,H27 STRAP,WEBBING.....	1
40	PAOZZ	5340004895684	19220	6411-B	UOC:A11,A24,A25,A26,A27,B17,B18,B24, B25,C17,H11,H17,H18,H24,H25,H26,H27, MMM LOOP,STRAP FASTENER.....	1

END OF FIGURE

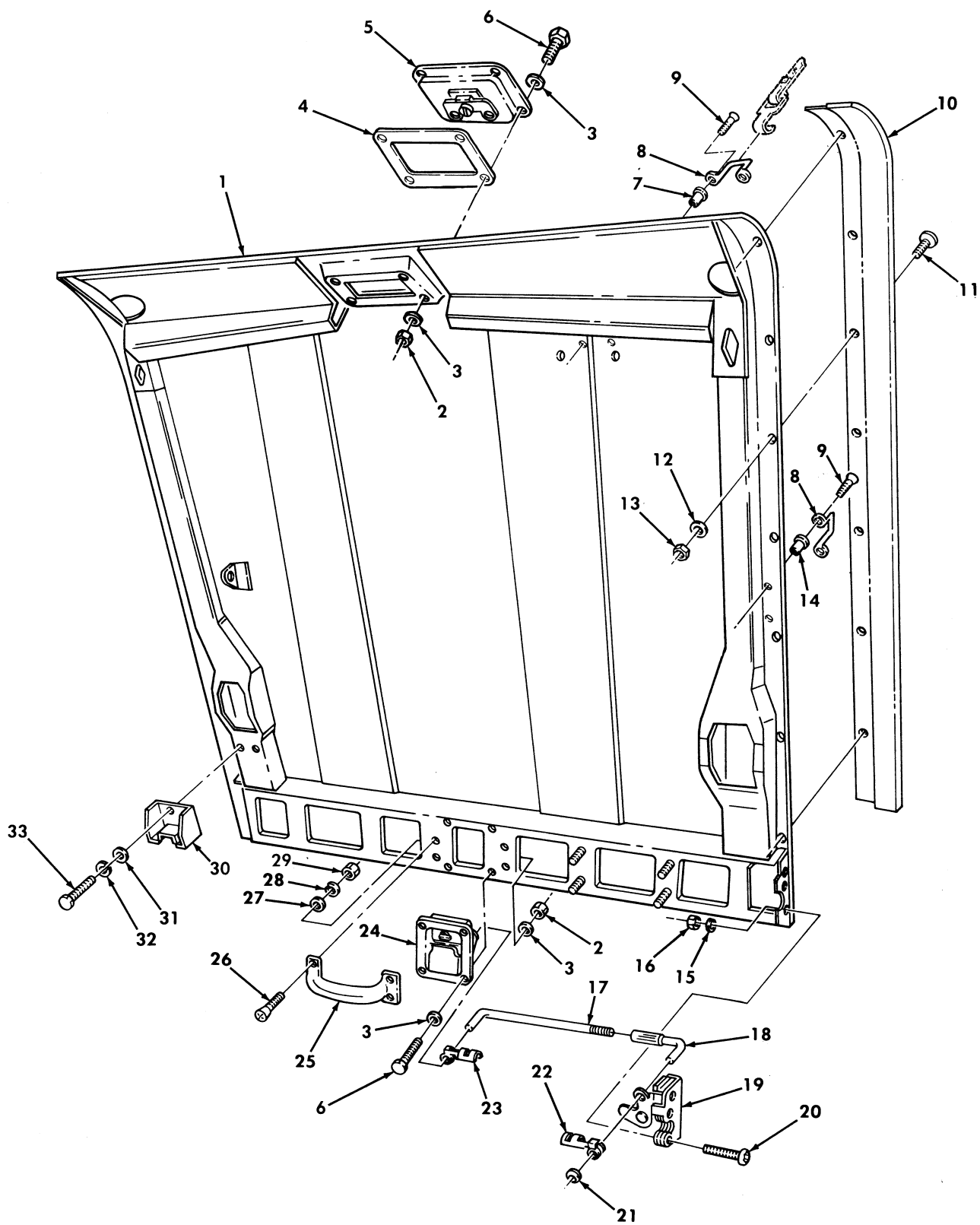

Figure 269. Cargo Shell Door Assembly, Basic and Supplemental Armor.

SECTION II			TM9-2320-280-24P			
(1)	(2)	(3)	(4)	(5)	(6)	(7)
ITEM	SMR			PART		
NO	CODE	NSN	CAGEC	NUMBER	DESCRIPTION AND USABLE ON CODES(UC)	QTY
GROUP 1812 SPECIAL PURPOSE BODIES						
FIG. 269 CARGO SHELL DOOR ASSEMBLY, BASIC AND SUPPLEMENTAL ARMOR						
1	XAOZZ		34623	5574377	DOOR ASSEMBLY.....	1
					UOC:A11,H11,MMM	
1	XAOZZ		34623	5584358	DOOR ASSEMBLY.....	1
					UOC:B17,B18,H17,H18	
1	XAOZZ		34623	5595228	DOOR ASSEMBLY.....	1
					UOC:A24,A27,B24,H24,H27	
1	XAOZZ		19207	12446912	DOOR ASSEMBLY.....	1
					UOC:B25	
1	XAOZZ		19207	12446908	DOOR ASSEMBLY.....	1
					UOC:C17	
1	XAOZZ		34623	5595227	DOOR ASSEMBLY.....	1
					UOC:A25,A26,H25,H26	
2	PAOZZ	5310009349758	96906	MS35649-202	NUT,PLAIN,HEXAGON.....	8
					UOC:A11,A24,A25,A26,A27,B17,B18,B24, B25,C17,H11,H17,H18,H24,H25,H26,H27, MMM	
3	PAOZZ	5310012349416	96906	MS51412-2	WASHER,FLAT #10.....	16
					UOC:A11,A24,A25,A26,A27,B17,B18,B24, B25,C17,H11,H17,H18,H24,H25,H26,H27, MMM	
4	PAOZZ	5330014583810	19207	12341348	GASKET.....	1
					UOC:A11,A24,A25,A26,A27,B17,B18,B24, B25,C17,H11,H17,H18,H24,H25,H26,H27, MMM	
5	PAOZZ	5340012597601	19220	38-5611-UL	CATCH,FLUSH.....	1
					UOC:A11,A24,A25,A26,A27,B17,B18,B24, B25,C17,H11,H17,H18,H24,H25,H26,H27, MMM	
6	PAOZZ	5305011858674	7X677	9421294	SCREW,CAP,HEXAGON H #10-24 X 1/2...	8
					UOC:A11,A24,A25,A26,A27,B17,B18,B24, B25,C17,H11,H17,H18,H24,H25,H26,H27, MMM	
7	PAOZZ	5325014110066	78276	ALS4-1024-130	INSERT,SCREW THREAD.....	40
					UOC:B25	
7	PAOZZ	5325014110066	78276	ALS4-1024-130	INSERT,SCREW THREAD.....	38
					UOC:C17	
8	PAOZZ	5340004895684	19220	6411B	LOOP,STRAP FASTENER.....	20
					UOC:B25,C17	
9	PAOZZ	5305014108386	24617	156966	SCREW,MACHINE.....	40
					UOC:B25,C17	
10	PFOZZ	2540011924504	19207	12339646-1	SHIELD,DEFLECTOR,MI L.H.....	1
					UOC:A11,A24,A27,B24,H11,H24,H27,MMM	
10	PFOZZ	2540011929721	19207	12339646-2	SHIELD,DEFLECTOR,BL R.H.....	1
					UOC:A11,A24,A27,B24,H11,H24,H27,MMM	
11	PAOZZ	5305000680502	96906	MS90725-6	SCREW,CAP,HEXAGON H 1/4-20 X .75...	26
					UOC:A11,A24,A27,B24,H11,H24,H27,MMM	
12	PAOZZ	5310011023270	24617	2436161	WASHER,FLAT 1/4.....	26
					UOC:A11,A24,A27,B24,H11,H24,H27,MMM	

SECTION II			TM9-2320-280-24P			
(1)	(2)	(3)	(4)	(5)	(6)	(7)
ITEM	SMR			PART		
NO	CODE	NSN	CAGEC	NUMBER	DESCRIPTION AND USABLE ON CODES(UOC)	QTY
13	PAOZZ	5310000614650	96906	MS51943-31	NUT, SELF-LOCKING, HE 1/4-20.....	26
					UOC:A11, A24, A27, B24, H11, H24, H27, MMM	
14	PAOZZ		78276	ALS4-1024-225	INSERT, SCREW THREAD.....	2
					UOC:C17	
15	PAOZZ	5310004079566	96906	MS35338-45	WASHER, LOCK 5/16.....	12
					UOC:A11, A24, A25, A26, A27, B17, B18, B24, B25, C17, H11, H17, H18, H24, H25, H26, H27, MMM	
16	PAOZZ	5310008140673	96906	MS51943-33	NUT, SELF-LOCKING, HE 5/16-18.....	12
					UOC:A11, A24, A25, A26, A27, B17, B18, B24, B25, C17, H11, H17, H18, H24, H25, H26, H27, MMM	
17	PAOZZ	5306011950277	34623	5583141	BOLT, HOOK.....	4
					UOC:A11, A24, A25, A26, A27, B17, B18, B24, B25, C17, H11, H17, H18, H24, H25, H26, H27, MMM	
18	PAOZZ	5340011972736	19220	16386(75)	ROD END, THREADED.....	4
					UOC:A11, A24, A25, A26, A27, B17, B18, B24, B25, C17, H11, H17, H18, H24, H25, H26, H27, MMM	
19	PAOZZ	5340011996103	19220	3-400-R	LATCH, DOOR R.H. FRONT, LEFT REAR.....	2
					UOC:A11, A24, A25, A26, A27, B17, B18, B24, B25, C17, H11, H17, H18, H24, H25, H26, H27, MMM	
19	PAOZZ	5340011985455	19220	3-400-L (25)	PLATE, MOUNTING LATCH, DOOR L.H. FRONT & R.H. REAR.....	2
					UOC:A11, A24, A25, A26, A27, B17, B18, B24, B25, C17, H11, H17, H18, H24, H25, H26, H27, MMM	
20	PAOZZ	5305002264831	80204	B1821BH031C150N	SCREW, CAP, HEXAGON H 5/16-18 X 1.50.	12
					UOC:A11, A24, A25, A26, A27, B17, B18, B24, B25, C17, H11, H17, H18, H24, H25, H26, H27, MMM	
21	PAOZZ	5310012131333	78553	C183-012-4	PUSH ON NUT.....	8
					UOC:A11, A24, A25, A26, A27, B17, B18, B24, B25, C17, H11, H17, H18, H24, H25, H26, H27, MMM	
22	PAOZZ	5340011958837	78947	HS49745	CLIP, RETAINING R.H.....	4
					UOC:A11, A24, A25, A26, A27, B17, B18, B24, B25, C17, H11, H17, H18, H24, H25, H26, H27, MMM	
23	PAOZZ	5340011968158	78947	HS49746	CLIP-CLEVIS, ROD RET L.H.....	4
					UOC:A11, A24, A25, A26, A27, B17, B18, B24, B25, C17, H11, H17, H18, H24, H25, H26, H27, MMM	
24	PAOZZ	5340012598600	19220	34-4974-51X	CATCH, FLUSH.....	1
					UOC:A11, A24, A25, A26, A27, B17, B18, B24, B25, C17, H11, H17, H18, H24, H25, H26, H27, MMM	
25	PFOZZ	5340011978239	14557	U-6236	HANDLE, BOW FRONT.....	1
					UOC:A11, A24, A25, A26, A27, B17, B18, B24, B25, C17, H11, H17, H18, H24, H25, H26, H27, MMM	

SECTION II			TM9-2320-280-24P			
(1)	(2)	(3)	(4)	(5)	(6)	(7)
ITEM	SMR			PART		
NO	CODE	NSN	CAGEC	NUMBER	DESCRIPTION AND USABLE ON CODES(UC)	QTY
26	PAOZZ	5305012542453	34623	5592861	SCREW,MACHINE #12-24 X 3/4..... UOC:A11,A24,A25,A26,A27,B17,B18,B24, B25,C17,H11,H17,H18,H24,H25,H26,H27, MMM	4
27	PAOZZ	5310011023270	24617	2436161	WASHER,FLAT 1/4..... UOC:A11,A24,A25,A26,A27,B17,B18,B24, B25,C17,H11,H17,H18,H24,H25,H26,H27, MMM	4
28	PAOZZ	5310002857037	96906	MS122031	WASHER,LOCK #12..... UOC:A11,A24,A25,A26,A27,B17,B18,B24, B25,C17,H11,H17,H18,H24,H25,H26,H27, MMM	4
29	PAOZZ	5310012544258	34623	5593000	NUT,PLAIN,HEXAGON #12-24..... UOC:A11,A24,A25,A26,A27,B17,B18,B24, B25,C17,H11,H17,H18,H24,H25,H26,H27, MMM	4
30	PAOZZ	5342011945806	19207	12339579	BRACKET,DOVETOIL..... UOC:A11,A24,A25,A26,A27,B17,B18,B24, B25,C17,H11,H17,H18,H24,H25,H26,H27, MMM	1
31	PAOZZ	5310008094058	96906	MS27183-10	WASHER,FLAT 1/4..... UOC:A11,A24,A25,A26,A27,B17,B18,B24, B25,C17,H11,H17,H18,H24,H25,H26,H27, MMM	2
32	PAOZZ	5310005501130	96906	MS35333-40	WASHER,LOCK 1/4..... UOC:A11,A24,A25,A26,A27,B17,B18,B24, B25,C17,H11,H17,H18,H24,H25,H26,H27, MMM	2
33	PAOZZ	5305000680508	80204	B1821BH025C075N	SCREW,CAP,HEXAGON H 1/4-20 X 3/4... UOC:A11,A24,A25,A26,A27,B17,B18,B24, B25,C17,H11,H17,H18,H24,H25,H26,H27, MMM	2

END OF FIGURE

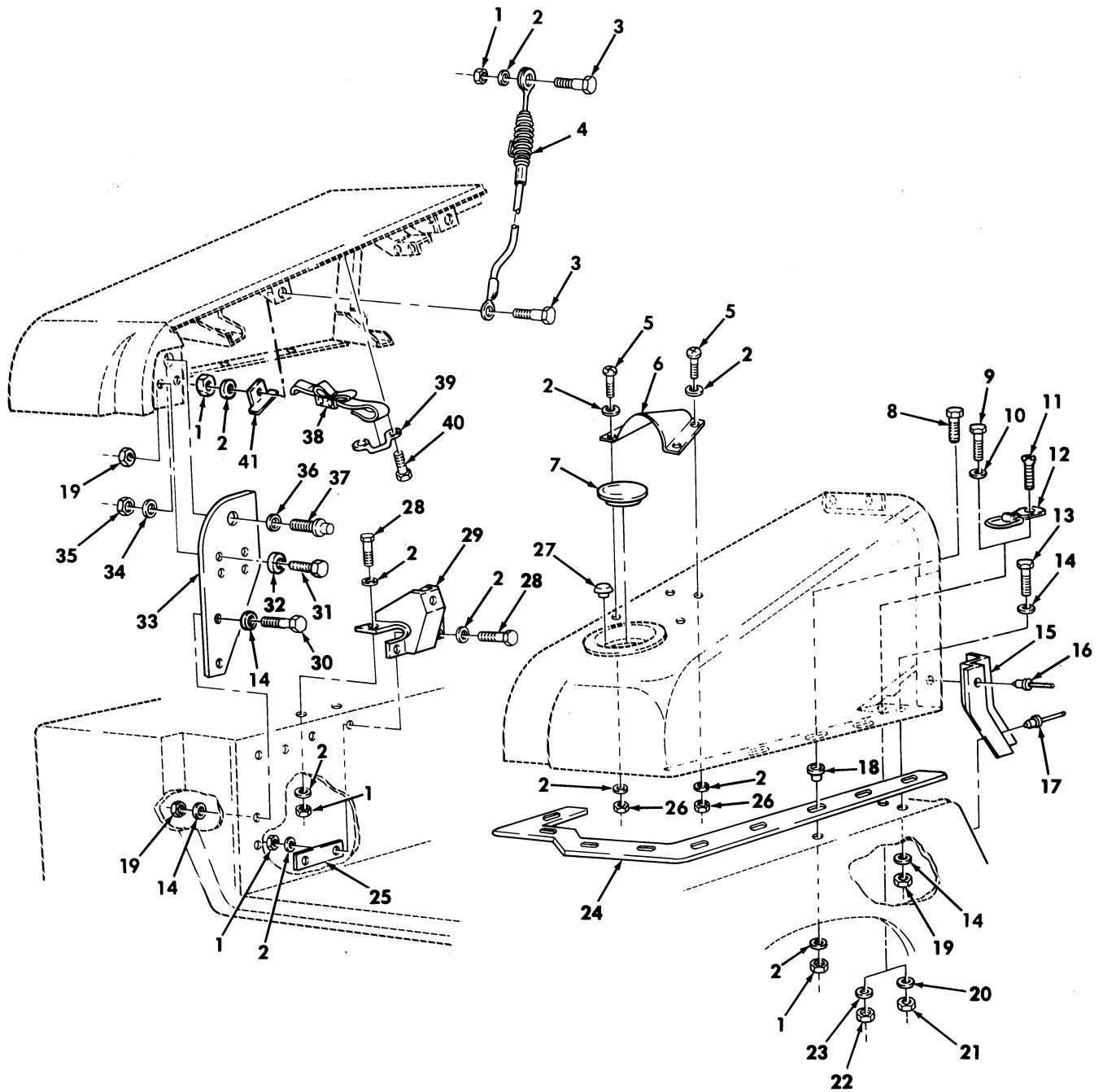

Figure 270. Cargo Shell Mounting Components.



SECTION II			TM9-2320-280-24P			
(1)	(2)	(3)	(4)	(5)	(6)	(7)
ITEM NO	SMR CODE	NSN	CAGEC	PART NUMBER	DESCRIPTION AND USABLE ON CODES(UC)	QTY
GROUP 1812 SPECIAL PURPOSE BODIES						
FIG. 270 CARGO SHELL MOUNTING COMPONENTS						
1	PAOZZ	5310000614650	96906	MS51943-31	NUT, SELF-LOCKING, HE 1/4-20.....	30
					UOC:A11, A24, A25, A26, A27, B17, B18, B24, B25, C17, H11, H17, H18, H24, H25, H26, H27, MMM	
2	PAOZZ	5310011023270	24617	2436161	WASHER, FLAT 1/4.....	46
					UOC:A11, A24, A25, A27, B17, B18, B24, B25, C17, H11, H17, H18, H24, H25, H27, MMM	
2	PAOZZ	5310011023270	24617	2436161	WASHER, FLAT 1/4.....	28
					UOC:A26, H26	
3	PAOZZ	5306011991314	19207	12340001-2	BOLT, SHOULDER 1/4-20 X .75.....	4
					UOC:A11, A24, A25, A26, A27, B17, B18, B24, B25, C17, H11, H17, H18, H24, H25, H26, H27, MMM	
4	PAOZZ	4010012030412	58538	10812	WIRE ROPE ASSEMBLY, .....	2
					UOC:A11, A24, A25, A26, A27, B17, B18, B24, B25, C17, H11, H17, H18, H24, H25, H26, H27, MMM	
5	PAOZZ	5305000680502	96906	MS90725-6	SCREW, CAP, HEXAGON H 1/4-20 X 3/4...	4
					UOC:A11, A24, A27, B24, H11, H24, H27, MMM	
6	PAOZZ	2590011887394	19207	12339642	SHIELD, BLAST, VEHICU.....	1
					UOC:A11, A24, A27, B24, H11, H24, H27, MMM	
7	PAOZZ	5340011940887	99017	BPF-3-1/2	PLUG, PROTECTIVE, DUS.....	1
					UOC:A11, A24, A25, A26, A27, B17, B18, B24, B25, C17, H11, H17, H18, H24, H25, H26, H27, MMM	
8	PFFZZ	5305000680509	80204	B1821BH025C125N	SCREW, CAP, HEXAGON H 1/4-20 X 1.25..	18
					UOC:A11, A24, A25, A26, A27, B17, B18, B24, B25, C17, H11, H17, H18, H24, H25, H26, H27, MMM	
9	PAFZZ	5305007252317	80204	B1821BH038C150N	SCREW, CAP, HEXAGON H 3/8-16 X 1.50..	2
					UOC:A11, A24, A27, B24, H11, H24, H27, MMM	
10	PAFZZ	5310014727368	19207	12340880	WASHER, FLAT.....	2
					UOC:A11, A24, A27, B24, H11, H24, H27, MMM	
11	PAOZZ	5305000522232	96906	MS24667-77	SCREW, CAP, SOCKET HE.....	2
					UOC:A25, A26, B17, B18, B25, C17, H17, H18, H25, H26	
12	PAOZZ	3990013148393	19207	12342077	TIE DOWN, CARGO, VEHI.....	2
					UOC:A25, A26, B17, B18, H17, H18, H25, H26	
12	PAOZZ	3990014325370	19207	12446987	TIE DOWN, CARGO, VEHI.....	2
					UOC:B25, C17	
13	PAFZZ	5305007252317	80204	B1821BH038C150N	SCREW, CAP, HEXAGON H 3/8-16 X 1.50..	2
					UOC:A11, A24, A25, A26, A27, B17, B18, B24, B25, C17, H11, H17, H18, H24, H25, H26, H27, MMM	
14	PAFZZ	5310000877493	96906	MS27183-13	WASHER, FLAT 3/8.....	24
					UOC:A11, A24, A25, A26, A27, B17, B18, B24, B25, C17, H11, H17, H18, H24, H25, H26, H27, MMM	
15	PFFZZ	2540011928283	34623	5584152	PANEL, FILLER DOOR S R.H., REAR.....	1
					UOC:A11, A24, A25, A26, A27, B17, B18, B24,	

SECTION II			TM9-2320-280-24P			
(1)	(2)	(3)	(4)	(5)	(6)	(7)
ITEM NO	SMR CODE	NSN	CAGEC	PART NUMBER	DESCRIPTION AND USABLE ON CODES(UOC)	QTY
15	PFFZZ	2510011925950	34623	5584151	B25,C17,H11,H17,H18,H24,H25,H26,H27, MMM PANEL,CAB L.H.,REAR.....	1
					UOC:A11,A24,A25,A26,A27,B17,B18,B24, B25,C17,H11,H17,H18,H24,H25,H26,H27, MMM	
16	PAFZZ	5320008990981	54402	AD42BS	RIVET,BLIND 1/8 DIA.....	1
					UOC:A11,A24,A25,A26,A27,B17,B18,B24, B25,C17,H11,H17,H18,H24,H25,H26,H27, MMM	
17	PAFZZ	5320000835009	81349	M24243/1-A403	RIVET,BLIND 1/8 DIA.....	4
					UOC:A11,A24,A25,A26,A27,B17,B18,B24, B25,C17,H11,H17,H18,H24,H25,H26,H27, MMM	
18	PAFZZ	5365011945093	34623	5583156	SPACER,SLEEVE.....	18
					UOC:A11,A24,A25,A26,A27,B17,B18,B24, B25,C17,H11,H17,H18,H24,H25,H26,H27, MMM	
19	PAFZZ	5310009359021	96906	MS51943-35	NUT,SELF-LOCKING,HE 3/8-16.....	17
					UOC:A11,A24,A25,A26,A27,B17,B18,B24, B25,C17,H11,H17,H18,H24,H25,H26,H27, MMM	
20	PAFZZ	5310014124013	24617	2436163	WASHER,FLAT.....	2
					UOC:A11,A24,A27,B24,H11,H24,H27,MMM	
21	PAFZZ	5310009359021	96906	MS51943-35	NUT,SELF-LOCKING,HE.....	2
					UOC:A11,A24,A27,B24,H11,H24,H27,MMM	
22	PAOZZ	5310004883889	96906	MS51943-39	NUT,SELF-LOCKING,HE.....	2
					UOC:A25,A26,B17,B18,B25,C17,H17,H18, H25,H26	
23	PAOZZ	5310013968392	80205	NAS1149F0863P	WASHER,FLAT 1/2.....	2
					UOC:A25,A26,B17,B18,B25,C17,H17,H18, H25,H26	
24	PAFZZ	5330011959049	34623	5593930	SEAL,NONMETALLIC ST L.H.....	1
					UOC:A11,A24,A25,A26,A27,B17,B18,B24, B25,C17,H11,H17,H18,H24,H25,H26,H27, MMM	
25	PFOZZ	5340011972642	19207	12339605	PLATE,MENDING.....	2
					UOC:A11,A24,A25,A26,A27,B17,B18,B24, B25,C17,H11,H17,H18,H24,H25,H26,H27, MMM	
26	PAOZZ	5310000614650	96906	MS51943-31	NUT,SELF-LOCKING,HE 1/4-20.....	4
					UOC:A11,A24,A25,A26,A27,B17,B18,B24, B25,C17,H11,H17,H18,H24,H25,H26,H27, MMM	
27	PAOZZ	5340011940888	99017	BPF-3/8-3	PLUG,PROTECTIVE,DUS.....	4
					UOC:A11,A24,A25,A26,A27,B17,B18,B24, B25,C17,H11,H17,H18,H24,H25,H26,H27, MMM	
28	PAOZZ	5305000680508	80204	B1821BH025C075N	SCREW,CAP,HEXAGON H 1/4-20 X 3/4...	8
					UOC:A11,A24,A25,A26,A27,B17,B18,B24, B25,C17,H11,H17,H18,H24,H25,H26,H27, MMM	
29	PFOZZ	5340011972716	34623	5584138	BRACKET,MOUNTING.....	2
					UOC:A11,A24,A25,A26,A27,B17,B18,B24,	

SECTION II			TM9-2320-280-24P			
(1)	(2)	(3)	(4)	(5)	(6)	(7)
ITEM NO	SMR CODE	NSN	CAGEC	PART NUMBER	DESCRIPTION AND USABLE ON CODES(UC)	QTY
30	PAOZZ	5305007252317	80204	B1821BH038C150N	B25,C17,H11,H17,H18,H24,H25,H26,H27,MMM SCREW,CAP,HEXAGON H 3/8-16 X 1.50..	10
31	PAOZZ	5306013877457	34623	5593200	UOC:A11,A24,A25,A26,A27,B17,B18,B24,B25,C17,H11,H17,H18,H24,H25,H26,H27,MMM BOLT,MACHINE 3/8-16 X 1.25.....	2
32	PAOZZ	5310012057923	34623	5593213	UOC:A11,A24,A25,A26,A27,B17,B18,B24,B25,C17,H11,H17,H18,H24,H25,H26,H27,MMM WASHER,FLAT 3/8.....	2
33	PFOZZ	2540012528460	19207	12339610-1	UOC:A11,A24,A25,A26,A27,B17,B18,B24,B25,C17,H11,H17,H18,H24,H25,H26,H27,MMM PLATE,STRIKE L.H.....	1
33	PFOZZ	2540012523386	34623	12339610-2	UOC:A11,A24,A25,A26,A27,B17,B18,B24,B25,C17,H11,H17,H18,H24,H25,H26,H27,MMM PLATE,STRIKER,MOUNT R.H.....	1
34	PAOZZ	5310012604839	34623	5593312	UOC:A11,A24,A25,A26,A27,B17,B18,B24,B25,C17,H11,H17,H18,H24,H25,H26,H27,MMM WASHER,FLAT 3/4.....	2
35	PAOZZ	5310004093333	96906	MS51943-45	UOC:A11,A24,A25,A26,A27,B17,B18,B24,B25,C17,H11,H17,H18,H24,H25,H26,H27,MMM NUT,SELF-LOCKING,HE 3/4-10.....	2
36	PAOZZ	5310011971100	19207	12339599	UOC:A11,A24,A25,A26,A27,B17,B18,B24,B25,C17,H11,H17,H18,H24,H25,H26,H27,MMM WASHER,FLAT 25/32.....	2
37	PAOZZ	5340014401435	34623	5596198	UOC:A11,A24,A25,A26,A27,B17,B18,B24,B25,C17,H11,H17,H18,H24,H25,H26,H27,MMM STUD,FRICITION CATCH.....	2
38	PAOZZ	5340012035634	31272	44647-10	UOC:A11,A24,A25,A26,A27,B17,B18,B24,B25,C17,H11,H17,H18,H24,H25,H26,H27,MMM STRAP,WEBBING.....	4
39	PAOZZ	5340004895684	19220	6411-B	UOC:A11,A24,A25,A26,A27,B17,B18,B24,B25,C17,H11,H17,H18,H24,H25,H26,H27,MMM LOOP,STRAP FASTENER.....	4
40	PAOZZ	5305012542459	34623	5593313	UOC:A11,A24,A25,A26,A27,B17,B18,B24,B25,C17,H11,H17,H18,H24,H25,H26,H27,MMM SCREW,ASSEMBLED WAS #10-32 X 3/4...	8
41	PAOZZ	5340014605002	19207	12339601	UOC:A11,A24,A25,A26,A27,B17,B18,B24,B25,C17,H11,H17,H18,H24,H25,H26,H27,MMM BRACKET,ANGLE.....	2

END OF FIGURE

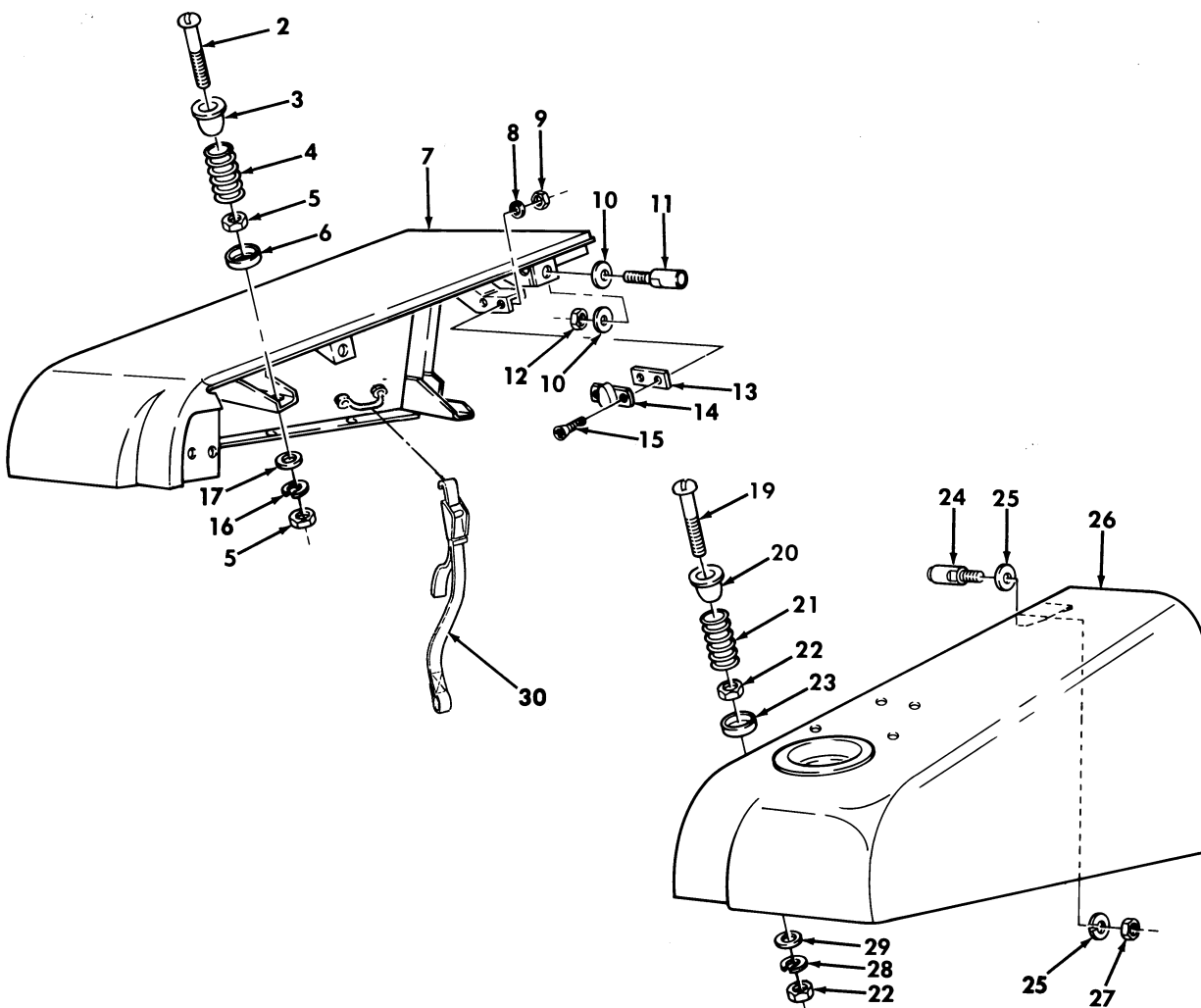
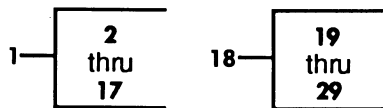

Figure 271. Cargo Shell Assemblies.

SECTION II			TM9-2320-280-24P			
(1)	(2)	(3)	(4)	(5)	(6)	(7)
ITEM	SMR			PART		
NO	CODE	NSN	CAGEC	NUMBER	DESCRIPTION AND USABLE ON CODES(UOC)	QTY
GROUP 1812 SPECIAL PURPOSE BODIES						
FIG. 271 CARGO SHELL ASSEMBLIES						
1	PFFFF	2510013454365	19207	12339644-5	SHELL,CARGO,VEHICUL BASIC ARMOR, L.H..... UOC:A11,H11,MMM	1
1	PFFFF	2510013320128	19207	12339644-7	SHELL,CARGO,VEHICUL BASIC ARMOR, L.H..... UOC:B17,B18,C17,H17,H18	1
1	PFFFF	2510013320129	19207	12339655-10	SHELL,CARGO,VEHICUL SUPPLEMENTAL ARMOR,L.H..... UOC:A25,A26,B25,H25,H26	1
1	PFFFF	2510013486670	19207	12339655-7	SHELL,CARGO,VEHICUL SUPPLEMENTAL ARMOR,L.H..... UOC:A24,A27,B24,H24,H27	1
2	PAOZZ	5305011971594	19207	12339548	.SCREW,MACHINE 1/2-20 X 3.00..... UOC:A11,A24,A25,A26,A27,B17,B18,B24, B25,C17,H11,H17,H18,H24,H25,H26,H27, MMM	1
3	PAOZZ	2540012096049	19207	12339546	.RETAINER,HELICAL CO..... UOC:A11,A24,A25,A26,A27,B17,B18,B24, B25,C17,H11,H17,H18,H24,H25,H26,H27, MMM	1
4	PAOZZ	5360011946070	19207	12339547	.SPRING,HELICAL,COMP..... UOC:A11,A24,A25,A26,A27,B17,B18,B24, B25,C17,H11,H17,H18,H24,H25,H26,H27, MMM	1
5	PAOZZ	5310009432141	96906	MS51968-15	.NUT,PLAIN,HEXAGON 1/2-20..... UOC:A11,A24,A25,A26,A27,B17,B18,B24, B25,C17,H11,H17,H18,H24,H25,H26,H27, MMM	2
6	PAOZZ	5340012144992	19207	12339545	.RETAINER,HELICAL CO..... UOC:A11,A24,A25,A26,A27,B17,B18,B24, B25,C17,H11,H17,H18,H24,H25,H26,H27, MMM	1
7	XAFZZ		19207	12339634-3	.CARGO SHELL L.H..... UOC:A11,H11,MMM	1
7	XAFZZ		19207	12339634-4	.CARGO SHELL L.H..... UOC:B17,B18,C17,H17,H18	1
7	XAFZZ		19207	12339639-4	.CARGO SHELL L.H..... UOC:A24,A27,B24,H24,H27	1
7	XAFZZ		19207	12339639-3	.CARGO SHELL L.H..... UOC:A25,A26,B25,H25,H26	1
8	PAOZZ	5310011023270	24617	2436161	.WASHER,FLAT 1/4..... UOC:A11,A24,A25,A26,A27,B17,B18,B24, B25,C17,H11,H17,H18,H24,H25,H26,H27, MMM	2
9	PAOZZ	5310000614650	96906	MS51943-31	.NUT,SELF-LOCKING,HE 1/4-20..... UOC:A11,A24,A25,A26,A27,B17,B18,B24, B25,C17,H11,H17,H18,H24,H25,H26,H27, MMM	2
10	PAOZZ	5310008094085	96906	MS27183-16	.WASHER,FLAT 7/16.....	2

SECTION II			TM9-2320-280-24P			
(1)	(2)	(3)	(4)	(5)	(6)	(7)
ITEM	SMR			PART		
NO	CODE	NSN	CAGEC	NUMBER	DESCRIPTION AND USABLE ON CODES(UOC)	QTY
					UOC:A11,A24,A25,A26,A27,B17,B18,B24, B25,C17,H11,H17,H18,H24,H25,H26,H27, MMM	
11	PAOZZ	5315012896212	19207	12339544	.PIN,SHOULDER,HEADLE.....	1
					UOC:A11,A24,A25,A26,A27,B17,B18,B24, B25,C17,H11,H17,H18,H24,H25,H26,H27, MMM	
12	PAOZZ	5310011504003	24617	9422299	.NUT,SELF-LOCKING,HE 7/16-14.....	1
					UOC:A11,A24,A25,A26,A27,B17,B18,B24, B25,C17,H11,H17,H18,H24,H25,H26,H27, MMM	
13	PAOZZ	5365011290399	19207	7529300	.SPACER,PLATE.....	1
					UOC:A11,A24,A25,A26,A27,B17,B18,B24, B25,C17,H11,H17,H18,H24,H25,H26,H27, MMM	
14	PAOZZ	2540000402129	19207	8329899	.WEDGE,DOOR DOVETAIL.....	1
					UOC:A11,A24,A25,A26,A27,B17,B18,B24, B25,C17,H11,H17,H18,H24,H25,H26,H27, MMM	
15	PAOZZ	5305009585246	80205	MS35190-289	.SCREW,MACHINE 1/4-20 X 3/4.....	2
					UOC:A11,A24,A25,A26,A27,B17,B18,B24, B25,C17,H11,H17,H18,H24,H25,H26,H27, MMM	
16	PAOZZ	5310005845272	02978	ERNA245	.WASHER,LOCK 1/2.....	1
					UOC:A11,A24,A25,A26,A27,B17,B18,B24, B25,C17,H11,H17,H18,H24,H25,H26,H27, MMM	
17	PAOZZ	5310011211703	11862	2436165	.WASHER,FLAT 1/2.....	1
					UOC:A11,A24,A25,A26,A27,B17,B18,B24, B25,C17,H11,H17,H18,H24,H25,H26,H27, MMM	
18	PFFFF	2510013444169	19207	12339644-6	SHELL,CARGO,VEHICUL BASIC ARMOR, R.H.....	1
					UOC:A11,H11,MMM	
18	PFFFF	2510013540417	19207	12339644-8	SHELL,CARGO,VEHICUL BASIC ARMOR, R.H.....	1
					UOC:B17,B18,C17,H17,H18	
18	PFFFF	2510013666968	19207	12339655-6	SHELL,CARGO,VEHICUL SUPPLEMENTAL ARMOR,R.H.....	1
					UOC:A25,A26,B25,H25,H26	
18	PFFFF	2510013666969	19207	12339655-8	SHELL,CARGO,VEHICUL SUPPLEMENTAL ARMOR,R.H.....	1
					UOC:A24,A27,B24,H24,H27	
19	PAOZZ	5305011971594	19207	12339548	.SCREW,MACHINE 1/2-20 X 3.00.....	1
					UOC:A11,A24,A25,A26,A27,B17,B18,B24, B25,C17,H11,H17,H18,H24,H25,H26,H27, MMM	
20	PAOZZ	2540012096049	19207	12339546	.RETAINER,HELICAL CO.....	1
					UOC:A11,A24,A25,A26,A27,B17,B18,B24, B25,C17,H11,H17,H18,H24,H25,H26,H27, MMM	
21	PAOZZ	5360011946070	19207	12339547	.SPRING,HELICAL,COMP.....	1
					UOC:A11,A24,A25,A26,A27,B17,B18,B24,	

SECTION II			TM9-2320-280-24P			
(1)	(2)	(3)	(4)	(5)	(6)	(7)
ITEM NO	SMR CODE	NSN	CAGEC	PART NUMBER	DESCRIPTION AND USABLE ON CODES(UOC)	QTY
22	PAOZZ	5310009432141	96906	MS51968-15	B25,C17,H11,H17,H18,H24,H25,H26,H27, MMM .NUT,PLAIN,HEXAGON 1/2-20.....	2
					UOC:A11,A24,A25,A26,A27,B17,B18,B24, B25,C17,H11,H17,H18,H24,H25,H26,H27, MMM	
23	PAOZZ	5340012144992	19207	12339545	.RETAINER,HELICAL CO.....	1
					UOC:A11,A24,A25,A26,A27,B17,B18,B24, B25,C17,H11,H17,H18,H24,H25,H26,H27, MMM	
24	PAOZZ	5315012896212	19207	12339544	.PIN,SHOULDER,HEADLE FRONT.....	1
					UOC:A11,A24,A25,A26,A27,B17,B18,B24, B25,C17,H11,H17,H18,H24,H25,H26,H27, MMM	
25	PAOZZ	5310008094085	96906	MS27183-16	.WASHER,FLAT 7/16.....	2
					UOC:A11,A24,A25,A26,A27,B17,B18,B24, B25,C17,H11,H17,H18,H24,H25,H26,H27, MMM	
26	XAFZZ		19207	12339635-3	.CARGO SHELL R.H.....	1
					UOC:A11,H11,MMM	
26	XAFZZ		19207	12339635-4	.CARGO SHELL R.H.....	1
					UOC:B17,B18,C17,H17,H18	
26	XAFZZ		19207	12339640-3	.CARGO SHELL R.H.....	1
					UOC:A25,A26,B25,H25,H26	
26	XAFZZ		19207	12339639-3	.CARGO SHELL R.H.....	1
					UOC:A24,A27,B24,H24,H27	
27	PAOZZ	5310011504003	24617	9422299	.NUT,SELF-LOCKING,HE 7/16-14.....	1
					UOC:A11,A24,A25,A26,A27,B17,B18,B24, B25,C17,H11,H17,H18,H24,H25,H26,H27, MMM	
28	PAOZZ	5310005845272	02978	ERNA245	.WASHER,LOCK 1/2.....	1
					UOC:A11,A24,A25,A26,A27,B17,B18,B24, B25,C17,H11,H17,H18,H24,H25,H26,H27, MMM	
29	PAOZZ	5310011211703	11862	2436165	.WASHER,FLAT 1/2.....	1
					UOC:A11,A24,A25,A26,A27,B17,B18,B24, B25,C17,H11,H17,H18,H24,H25,H26,H27, MMM	
30	PAOZZ	5340011982253	31272	45053-11	STRAP,WEBBING.....	2
					UOC:B24,B25,C17	

END OF FIGURE

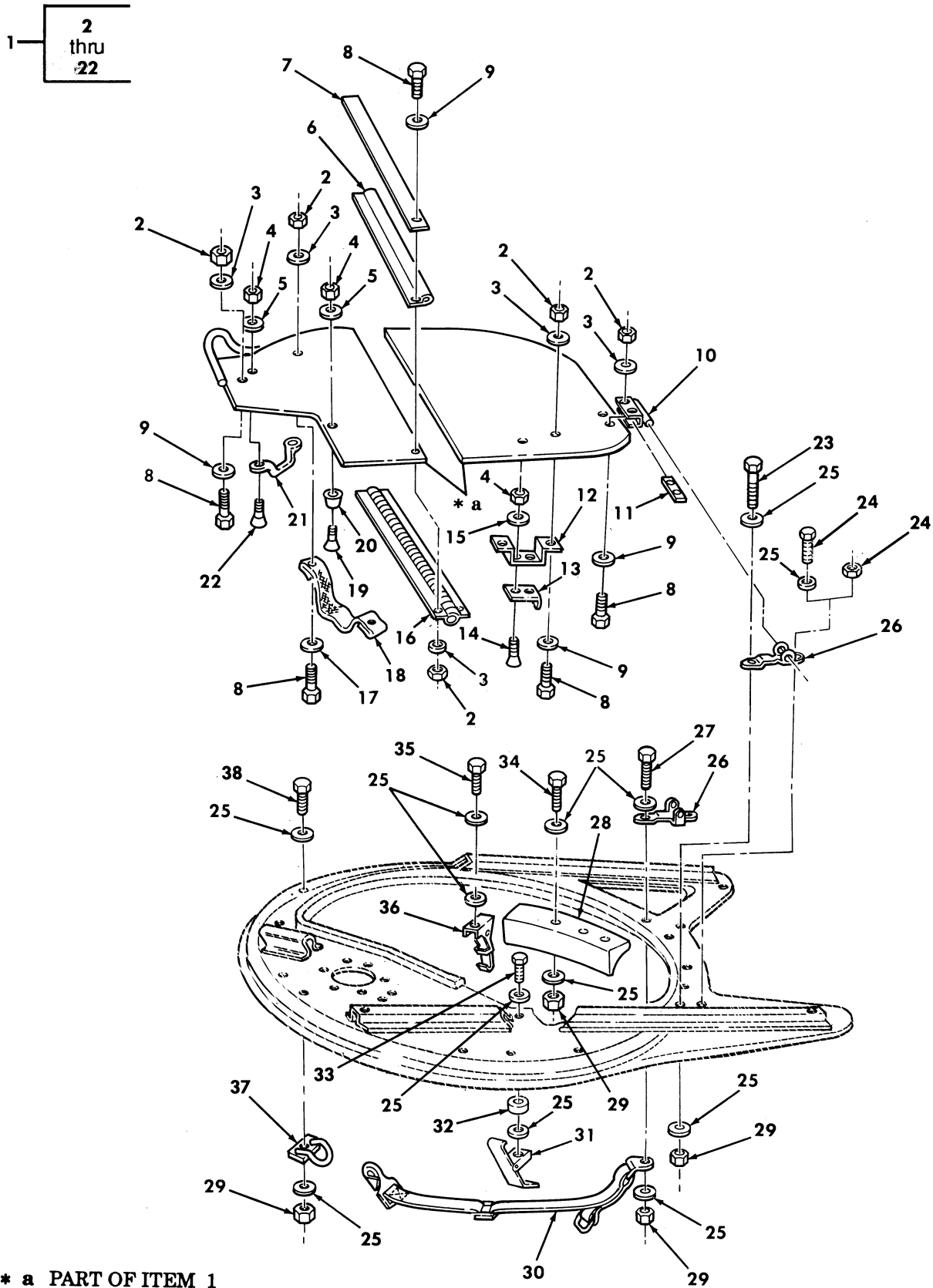

Figure 272. Weapon Station Hatch Assembly, Latch, Gunner's Sling, and Related Components.



SECTION II			TM9-2320-280-24P			
(1)	(2)	(3)	(4)	(5)	(6)	(7)
ITEM NO	SMR CODE	NSN	CAGEC	PART NUMBER	DESCRIPTION AND USABLE ON CODES(UOC)	QTY
GROUP 1812 SPECIAL PURPOSE BODIES						
FIG. 272 WEAPON STATION HATCH ASSEMBLY,LATCH,GUNNER'S SLING,AND RELATED COMPONENTS						
1	PAOZZ	2510012491585	19207	12340340	HATCH ASSEMBLY,WEAP..... UOC:A24,A25,A26,A27,B24,B25,H24,H25,H26,H27	1
1	PAOZZ	2510012491586	19207	12340347	DOOR,HATCH,VEHICLE..... UOC:A11,B17,B18,C17,H11,H17,H18,MMM	1
2	PAOZZ	5310000614650	96906	MS51943-31	.NUT,SELF-LOCKING,HE 1/4-20..... UOC:A11,A24,A25,A26,A27,B17,B18,B24,B25,C17,H11,H17,H18,H24,H25,H26,H27,MMM	27
3	PAOZZ	5310008094058	96906	MS27183-10	.WASHER,FLAT 1/4..... UOC:A11,A24,A25,A26,A27,B17,B18,B24,B25,C17,H11,H17,H18,H24,H25,H26,H27,MMM	27
4	PAOZZ	5310002081918	24617	190254	.NUT,SELF-LOCKING,HE #10-24..... UOC:A11,A24,A25,A26,A27,B17,B18,B24,B25,C17,H11,H17,H18,H24,H25,H26,H27,MMM	12
5	PAOZZ	5310012538951	34623	5593294	.WASHER,FLAT #10..... UOC:A11,A24,A25,A26,A27,B17,B18,B24,B25,C17,H11,H17,H18,H24,H25,H26,H27,MMM	8
6	PAOZZ	5330012584664	34623	5595531	.SEAL,NONMETALLIC SP..... UOC:A11,A24,A25,A26,A27,B17,B18,B24,B25,C17,H11,H17,H18,H24,H25,H26,H27,MMM	1
7	PFOZZ	2590012589491	19207	12340123	.MOLDING,METAL..... UOC:A11,A24,A25,A26,A27,B17,B18,B24,B25,C17,H11,H17,H18,H24,H25,H26,H27,MMM	1
8	PAOZZ	5305003900524	96906	MS51849-98	.SCREW,MACHINE 1/4-20 X 1.00..... UOC:A11,A24,A25,A26,A27,B17,B18,B24,B25,C17,H11,H17,H18,H24,H25,H26,H27,MMM	27
9	PAOZZ	5310011023270	24617	2436161	.WASHER,FLAT 1/4..... UOC:A11,A24,A25,A26,A27,B17,B18,B24,B25,C17,H11,H17,H18,H24,H25,H26,H27,MMM	25
10	PAOZZ	2510012532839	19207	12340126	.HINGE,DOOR VEHICULA..... UOC:A11,A24,A25,A26,A27,B17,B18,B24,B25,C17,H11,H17,H18,H24,H25,H26,H27,MMM	2
11	PFOZZ	5365012538975	19207	12340098	.SPACER,RING..... UOC:A11,A24,A25,A26,A27,B17,B18,B24,B25,C17,H11,H17,H18,H24,H25,H26,H27,MMM	2
12	PFOZZ	5340012538377	19207	12340124	.BRACKET,MULTIPLE AN..... UOC:A11,A24,A25,A26,A27,B17,B18,B24,B25,C17,H11,H17,H18,H24,H25,H26,H27,	1

SECTION II			TM9-2320-280-24P			
(1)	(2)	(3)	(4)	(5)	(6)	(7)
ITEM NO	SMR CODE	NSN	CAGEC	PART NUMBER	DESCRIPTION AND USABLE ON CODES(UOC)	QTY
13	PFOZZ	5340012116288	19207	12340096	MMM . STRIKE,CATCH..... UOC:A11,A24,A25,A26,A27,B17,B18,B24, B25,C17,H11,H17,H18,H24,H25,H26,H27, MMM	2
14	PAOZZ	5305011981621	7X677	156971	MMM . SCREW,MACHINE..... UOC:A11,A24,A25,A26,A27,B17,B18,B24, B25,C17,H11,H17,H18,H24,H25,H26,H27, MMM	2
15	PAOZZ	5310000145850	96906	MS27183-42	MMM . WASHER,FLAT #10..... UOC:A11,A24,A25,A26,A27,B17,B18,B24, B25,C17,H11,H17,H18,H24,H25,H26,H27, MMM	4
16	PAOZZ	2510012541056	19207	12340091	MMM . HINGE,DOOR VEHICULA..... UOC:A11,A24,A25,A26,A27,B17,B18,B24, B25,C17,H11,H17,H18,H24,H25,H26,H27, MMM	1
17	PAOZZ	5310012520513	34623	5592916	MMM . WASHER,FLAT 1/4..... UOC:A11,A24,A25,A26,A27,B17,B18,B24, B25,C17,H11,H17,H18,H24,H25,H26,H27, MMM	2
18	PAOZZ	5340012564656	31272	45057-10	MMM . STRAP,WEBBING..... UOC:A11,A24,A25,A26,A27,B17,B18,B24, B25,C17,H11,H17,H18,H24,H25,H26,H27, MMM	1
19	PAOZZ	5305009846214	96906	MS35206-267	MMM . SCREW,MACHINE #10-24 X 1.00..... UOC:A11,A24,A25,A26,A27,B17,B18,B24, B25,C17,H11,H17,H18,H24,H25,H26,H27, MMM	2
20	PAOZZ	5340012038675	76385	ZB-1079M.I.	MMM . BUMPER,NONMETALLIC..... UOC:A11,A24,A25,A26,A27,B17,B18,B24, B25,C17,H11,H17,H18,H24,H25,H26,H27, MMM	2
21	PAOZZ	5340011993499	34623	5582439	MMM . HANDLE,BOW..... UOC:A11,A24,A25,A26,A27,B17,B18,B24, B25,C17,H11,H17,H18,H24,H25,H26,H27, MMM	3
22	PAOZZ	5305012542452	34623	5593286	MMM . SCREW,MACHINE #10-24 X 1.00..... UOC:A11,A24,A25,A26,A27,B17,B18,B24, B25,C17,H11,H17,H18,H24,H25,H26,H27, MMM	6
23	PAOZZ	5305007813926	80204	B1821BH038C275N	MMM SCREW,CAP,HEXAGON H 3/8-16 X 2.75.. UOC:A11,A24,A25,A26,A27,B17,B18,B24, B25,C17,H11,H17,H18,H24,H25,H26,H27, MMM	1
24	PAOZZ	5305011409118	80204	B1821BH038C088N	MMM SCREW,CAP,HEXAGON H 3/8-16 X 7/8... UOC:A11,A24,A25,A26,A27,B17,B18,H11, H17,H18,H24,H25,H26,H27,MMM	2
24	PAOZZ	5310008140672	96906	MS51943-36	MMM NUT,SELF-LOCKING,HE 3/8-24..... UOC:B24,B25,C17	2
25	PAOZZ	5310000806004	96906	MS27183-14	MMM WASHER,FLAT 3/8..... UOC:A11,A24,A25,A26,A27,B17,B18,B24, B25,C17,H11,H17,H18,H24,H25,H26,H27, MMM	20

SECTION II			TM9-2320-280-24P			
(1)	(2)	(3)	(4)	(5)	(6)	(7)
ITEM	SMR			PART		
NO	CODE	NSN	CAGEC	NUMBER	DESCRIPTION AND USABLE ON CODES(UOC)	QTY
26	PFOZZ	3040011978727	19207	12446767	BRACKET,EYE,ROTATIN..... UOC:A11,A24,A25,A26,A27,B17,B18,B24, B25,C17,H11,H17,H18,H24,H25,H26,H27, MMM	2
27	PAOZZ	5305008213869	80204	B1821BH038C175N	SCREW,CAP,HEXAGON H..... UOC:A11,A24,A25,A26,A27,B17,B18,H11, H17,H18,H24,H25,H26,H27,MMM,	1
27	PAOZZ	5305008465703	80204	B1821BH038C300N	SCREW,CAP,HEXAGON H 3/8-16 X 3.00.. UOC:B24,B25,C17	1
28	PAOZZ	2590012047836	19207	12340313	PAD,CUSHIONING..... UOC:A11,A24,A25,A26,A27,B17,B18,B24, B25,C17,H11,H17,H18,H24,H25,H26,H27, MMM	2
29	PAOZZ	5310009359021	96906	MS51943-35	NUT,SELF-LOCKING,HE 3/8-16..... UOC:A11,A24,A25,A26,A27,B17,B18,B24, B25,C17,H11,H17,H18,H24,H25,H26,H27, MMM	7
30	PAOZZ	5340011994989	31272	44888	STRAP,WEBBING..... UOC:A11,A24,A25,A26,A27,B17,B18,B24, B25,C17,H11,H17,H18,H24,H25,H26,H27, MMM	1
31	PAOZZ	5340014342864	31272	12340648	LATCH,RIM..... UOC:A11,A24,A25,A26,A27,B17,B18,H11, H17,H18,H24,H25,H26,H27,MMM	3
31	PAOZZ	5340014342864	31272	12340648	LATCH,RIM RIGHT..... UOC:B24,B25,C17	1
32	PAOZZ	5365012120144	34623	5591575	SPACER,PLATE..... UOC:A11,A24,A25,A26,A27,B17,B18,B24, B25,C17,H11,H17,H18,H24,H25,H26,H27, MMM	1
33	PAOZZ	5305000680511	80204	B1821BH038C125N	SCREW,CAP,HEXAGON H 3/8-16 X 1.250.. UOC:A11,A24,A25,A26,A27,B17,B18,H11, H17,H18,H24,H25,H26,H27,MMM	3
33	PAOZZ	5305000680511	80204	B1821BH038C125N	SCREW,CAP,HEXAGON H 3/8-16 X 1.250.. UOC:B24,B25,C17	1
34	PAOZZ	5305007252317	80204	B1821BH038C150N	SCREW,CAP,HEXAGON H 3/8-16 X 1.50.. UOC:A11,A24,A25,A26,A27,B17,B18,H11, H17,H18,H24,H25,H26,H27,MMM	4
34	PAOZZ	5305005432866	80204	B1821BH038C250N	SCREW,CAP,HEXAGON H 3/8-16 X 2.50.. UOC:B24,B25,C17	4
35	PAOZZ	5305007813926	80204	B1821BH038C275N	SCREW,CAP,HEXAGON H 3/8-16 X 2.75.. UOC:B24,B25,C17	2
36	PAOZZ	5340012042543	31272	45307-10	CATCH,CLAMPING LEFT..... UOC:B24,B25,C17	2
37	PFOZZ	2590011974899	19207	12340293	HOOK,GUNNER SLING..... UOC:A11,A24,A25,A26,A27,B17,B18,B24, B25,C17,H11,H17,H18,H24,H25,H26,H27, MMM	1
38	PAOZZ	5305007829489	80204	B1821BH038C200N	SCREW,CAP,HEXAGON H 3/8-16 X 2.00.. UOC:A11,A24,A25,A26,A27,B17,B18,H11, H17,H18,H24,H25,H26,H27,MMM	1
38	PAOZZ	5305007813926	80204	B1821BH038C275N	SCREW,CAP,HEXAGON H 3/8-16 X 2.75.. UOC:B24,B25,C17	1

END OF FIGURE

6 —  
7  
thru  
20

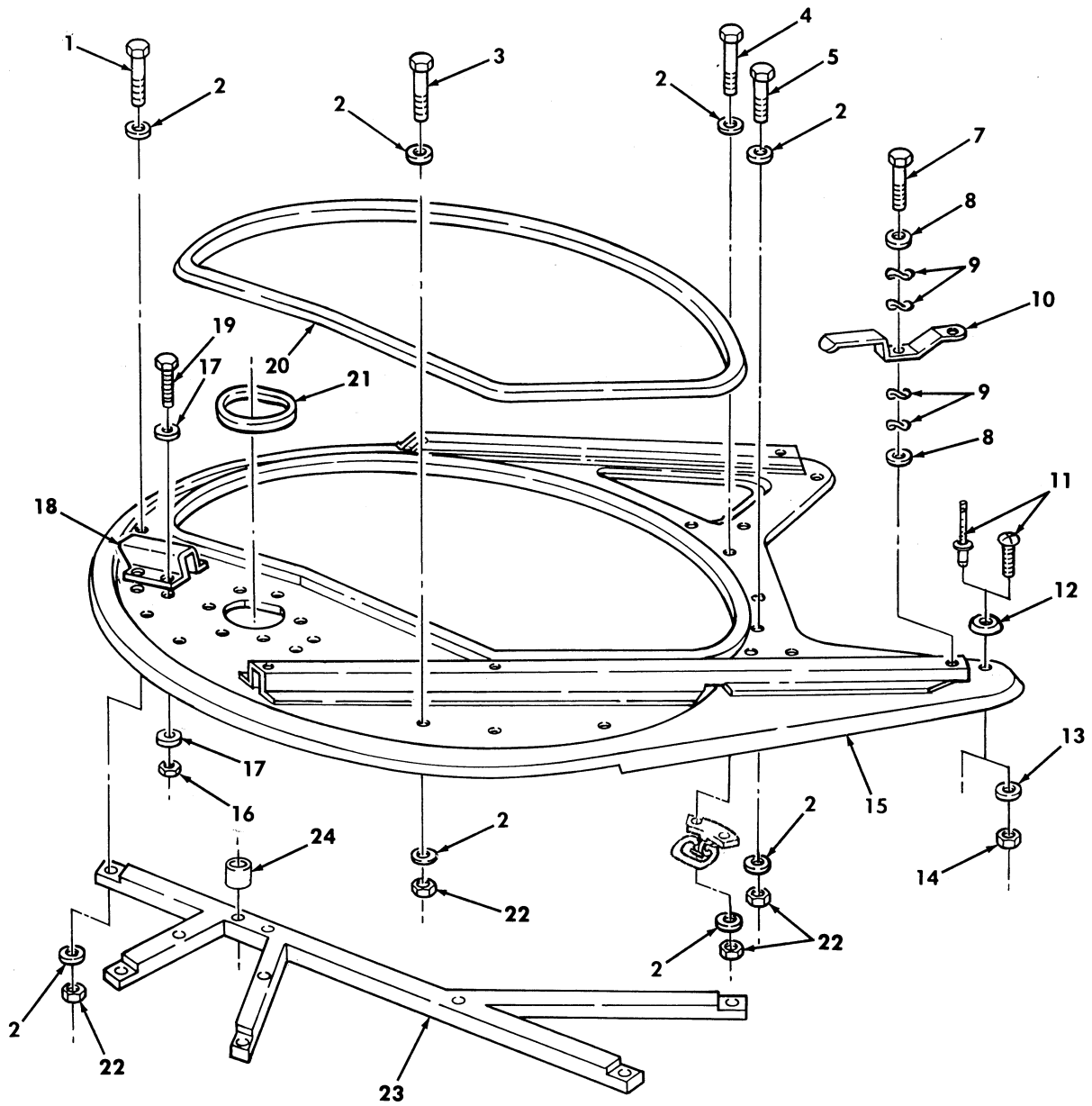

Figure 273. Weapon Station Tray Assembly, Reinforcement Tube, and Related Components.

SECTION II			TM9-2320-280-24P			
(1)	(2)	(3)	(4)	(5)	(6)	(7)
ITEM	SMR			PART		
NO	CODE	NSN	CAGEC	NUMBER	DESCRIPTION AND USABLE ON CODES(UOC)	QTY
GROUP 1812 SPECIAL PURPOSE BODIES						
FIG. 273 WEAPON STATION TRAY ASSEMBLY, REINFORCEMENT TUBE, AND RELATED COMPONENTS						
1	PAOZZ	5305007813926	80204	B1821BH038C275N	SCREW,CAP,HEXAGON H 3/8-16 X 2.75.. UOC:A11,A24,A25,A26,A27,B17,B18,H11, H17,H18,H24,H25,H26,H27,MMM	1
1	PAOZZ	5305009908632	80204	B1821BH038C375N	SCREW,CAP,HEXAGON H 3/8-16 X 3.75.. UOC:B24,B25,C17	1
2	PAOZZ	5310000806004	96906	MS27183-14	WASHER,FLAT 3/8.....	10
					UOC:A11,A24,A25,A26,A27,B17,B18,H11, H17,H18,H24,H25,H26,H27,MMM	
2	PAOZZ	5310000806004	96906	MS27183-14	WASHER,FLAT 3/8.....	8
					UOC:B24,B25,C17	
3	PAOZZ	5305007252317	80204	B1821BH038C150N	SCREW,CAP,HEXAGON H 3/8-16 X 1.50.. UOC:A11,A24,A25,A26,A27,B17,B18,B24, B25,C17,H11,H17,H18,H24,H25,H26,H27, MMM	1
4	PAOZZ	5305007829489	80204	B1821BH038C200N	SCREW,CAP,HEXAGON H 3/8-16 X 2.00.. UOC:A11,A24,A25,A26,A27,B17,B18,H11, H17,H18,H24,H25,H26,H27,MMM	2
4	PAOZZ	5305007813926	80204	B1821BH038C275N	SCREW,CAP,HEXAGON H 3/8-16 X 2.75.. UOC:B24,B25,C17	2
5	PAOZZ	5305005432866	80204	B1821BH038C250N	SCREW,CAP,HEXAGON H 3/8-16 X 2.50.. UOC:A11,A24,A25,A26,A27,B17,B18,B24, B25,C17,H11,H17,H18,H24,H25,H26,H27, MMM	1
6	PAOZZ	2590011899734	19207	12340346	TRAY,WEAPON,VEHICUL.....	1
					UOC:B24,B25,C17	
6	PAOZZ	2590014667250	19207	12446725	TRAY,WEAPON,VEHICUL.....	1
					UOC:A11,A24,A25,A26,A27,B17,B18,H11, H17,H18,H24,H25,H26,H27,MMM	
7	PAOZZ	5306002264826	80204	B1821BH031C088N	.BOLT,MACHINE 5/16-18 X 7/8.....	2
					UOC:A11,A24,A25,A26,A27,B17,B18,B24, B25,C17,H11,H17,H18,H24,H25,H26,H27, MMM	
8	PAOZZ	5310000814219	96906	MS27183-12	.WASHER,FLAT 5/16.....	4
					UOC:A11,A24,A25,A26,A27,B17,B18,B24, B25,C17,H11,H17,H18,H24,H25,H26,H27, MMM	
9	PAOZZ	5310012033230	73821	B0625-022-S	.WASHER,SPRING TENSI 5/16.....	8
					UOC:A11,A24,A25,A26,A27,B17,B18,B24, B25,C17,H11,H17,H18,H24,H25,H26,H27, MMM	
10	PAOZZ	3040011987473	19207	12340111	.LEVER,MANUAL CONTRO.....	2
					UOC:A11,A24,A25,A26,A27,B17,B18,B24, B25,C17,H11,H17,H18,H24,H25,H26,H27, MMM	
11	PAOZZ	5305009846194	96906	MS35206-246	.SCREW,MACHINE #8-32 X 5/8.....	2
					UOC:B24,B25,C17	
11	PAOZZ	5320014617924	24617	135927	.RIVET,TUBULAR 3/16 X 1/2.....	2
					UOC:A11,A24,A25,A26,A27,B17,B18,H11, H17,H18,H24,H25,H26,H27,MMM	

SECTION II			TM9-2320-280-24P			
(1)	(2)	(3)	(4)	(5)	(6)	(7)
ITEM NO	SMR CODE	NSN	CAGEC	PART NUMBER	DESCRIPTION AND USABLE ON CODES(UC)	QTY
12	PAOZZ	5340005655378	70485	698W	.BUMPER, NONMETALLIC..... UOC:A11, A24, A25, A26, A27, B17, B18, B24, B25, C17, H11, H17, H18, H24, H25, H26, H27, MMM	2
13	PAOZZ	5310012531618	96906	MS51412-18	.WASHER, FLAT #8..... UOC:A11, A24, A25, A26, A27, B17, B18, B24, B25, C17, H11, H17, H18, H24, H25, H26, H27, MMM	2
14	PAOZZ	5310008071466	96906	MS21042-08	.NUT, SELF-LOCKING, EX #8-32..... UOC:A11, A24, A25, A26, A27, B17, B18, B24, B25, C17, H11, H17, H18, H24, H25, H26, H27, MMM	2
15	XAOZZ		19207	12446727	.TRAY ASSEMBLY, WEAPO..... UOC:A11, A24, A25, A26, A27, B17, B18, H11, H17, H18, H24, H25, H26, H27, MMM	1
15	XAOZZ		19207	12340336	.TRAY ASSEMBLY, WEAPO..... UOC:B24, B25, C17	1
16	PAOZZ	5310002416658	96906	MS51943-34	.NUT, SELF-LOCKING, HE 5/16-24..... UOC:A11, A24, A25, A26, A27, B17, B18, B24, B25, C17, H11, H17, H18, H24, H25, H26, H27, MMM	4
17	PAOZZ	5310000814219	96906	MS27183-12	.WASHER, FLAT 5/16..... UOC:A11, A24, A25, A26, A27, B17, B18, B24, B25, C17, H11, H17, H18, H24, H25, H26, H27, MMM	8
18	PAOZZ	5340014571778	19207	12446730	.HANDLE, BOW..... UOC:A11, A24, A25, A26, A27, B17, B18, B24, B25, C17, H11, H17, H18, H24, H25, H26, H27, MMM	1
19	PAOZZ	5306002264824	80204	B1821BH031C063N	.BOLT, MACHINE 5/16-18 X .625..... UOC:A11, A24, A25, A26, A27, B17, B18, B24, B25, C17, H11, H17, H18, H24, H25, H26, H27, MMM	4
20	PAOZZ	5330012028360	06968	1301	.SEAL, NONMETALLIC SP..... UOC:A11, A24, A25, A26, A27, B17, B18, B24, B25, C17, H11, H17, H18, H24, H25, H26, H27, MMM	1
21	PAOZZ	5330012058607	19207	123401103-2	TRIM, EDGE 15.39-15.65 INCHES LONG.. UOC:A11, A24, A25, A26, A27, B17, B18, B24, B25, C17, H11, H17, H18, H24, H25, H26, H27, MMM	1
22	PAOZZ	5310009359021	96906	MS51943-35	NUT, SELF-LOCKING, HE 3/8-16..... UOC:A11, A24, A25, A26, A27, B17, B18, H11, H17, H18, H24, H25, H26, H27, MMM	5
22	PAOZZ	5310009359021	96906	MS51943-35	NUT, SELF-LOCKING, HE 3/8-16..... UOC:B24, B25, C17	4
23	PAOZZ	4710011899727	19207	12340337	TUBE ASSEMBLY, WEAPO..... UOC:A11, A24, A25, A26, A27, B17, B18, B24, B25, C17, H11, H17, H18, H24, H25, H26, H27, MMM	1
24	PAOZZ	5365014578947	19207	12460208	SPACER, SPECIAL SHAP..... UOC:A11, A24, A25, A26, A27, B17, B18, B24, B25, C17, H11, H17, H18, H24, H25, H26, H27, MMM	5

END OF FIGURE

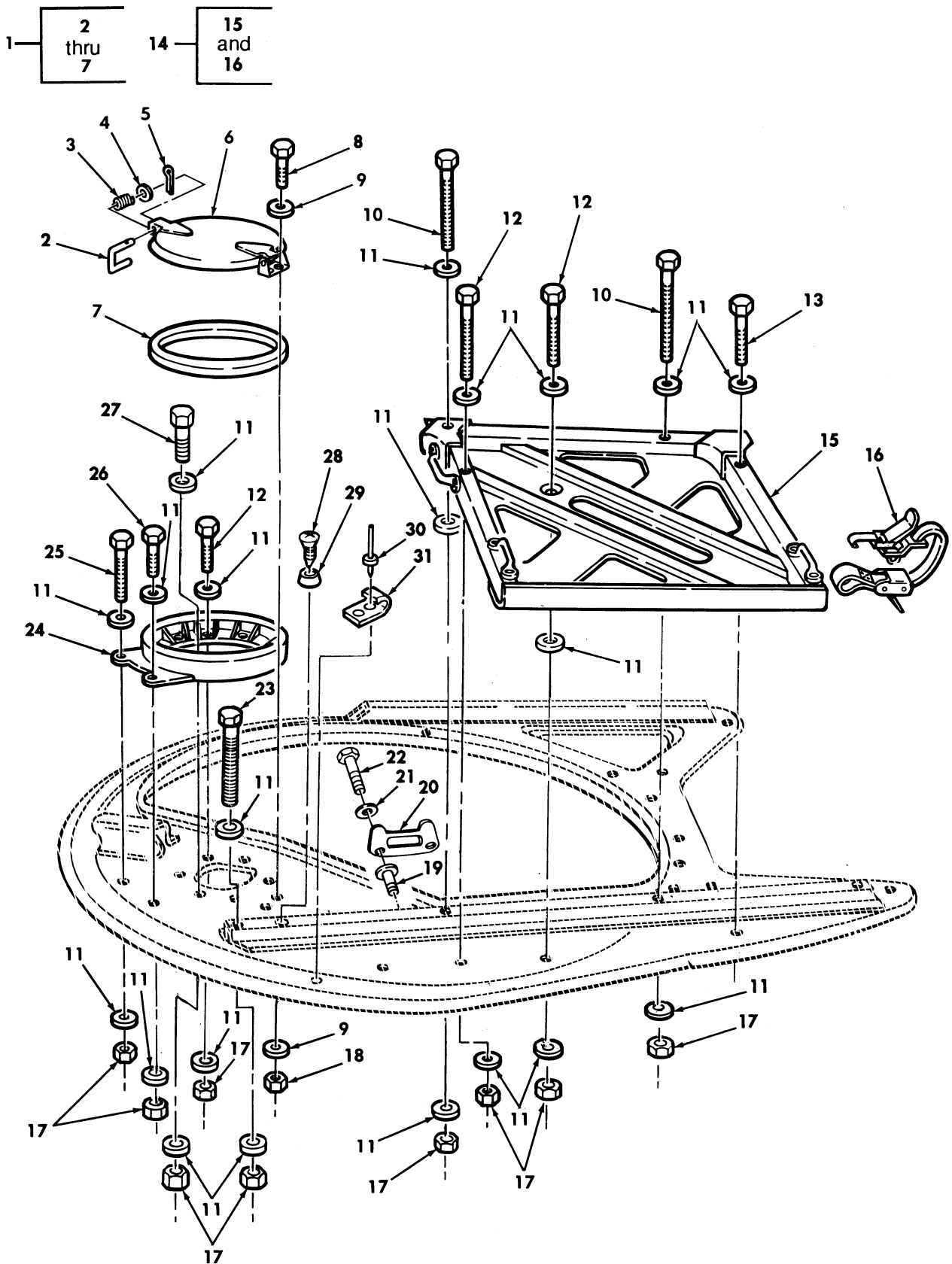

Figure 274. Weapon Station Tray Mounting, TOW Carrier.

SECTION II			TM9-2320-280-24P			
(1)	(2)	(3)	(4)	(5)	(6)	(7)
ITEM NO	SMR CODE	NSN	CAGEC	PART NUMBER	DESCRIPTION AND USABLE ON CODES(UOC)	QTY
GROUP 1812 SPECIAL PURPOSE BODIES						
FIG. 274 WEAPON STATION TRAY MOUNTING, TOW CARRIER						
1	PAOZZ	2510011899828	19207	12340311	DOOR, HATCH, VEHICLE.....	1
					UOC:A11, A24, A27, B24, H11, H24, H27, MMM	
2	PAOZZ	2510012573747	19207	12340104	. ROD, HOOD, VEHICULAR.....	1
					UOC:A11, A24, A27, B24, H11, H24, H27, MMM	
3	PAOZZ	5360011185907	70472	C0360-045-1250S	. SPRING, HELICAL, COMP.....	2
					UOC:A11, A24, A27, B24, H11, H24, H27, MMM	
4	PAOZZ	5310011023270	24617	2436161	. WASHER, FLAT 1/4.....	1
					UOC:A11, A24, A27, B24, H11, H24, H27, MMM	
5	PAOZZ	5315008392326	80205	MS24665-281	. PIN, COTTER 3/32 X 1/2.....	1
					UOC:A11, A24, A27, B24, H11, H24, H27, MMM	
6	PAOZZ	2510013102324	34623	5582436	. DOOR, HATCH, VEHICU.....	1
					UOC:A11, A24, A27, B24, H11, H24, H27, MMM	
7	PAOZZ	5330012701353	34623	5596580	. DISK, SOLID, PLAIN.....	1
					UOC:A11, A24, A27, B24, H11, H24, H27, MMM	
8	PAOZZ	5305000687837	80204	B1821BH025C063N	SCREW, CAP, HEXAGON H 1/4-20 X 5/8...	2
					UOC:A11, A24, A27, B24, H11, H24, H27, MMM	
9	PAOZZ	5310011023270	24617	2436161	WASHER, FLAT 1/4.....	4
					UOC:A11, A24, A27, B24, H11, H24, H27, MMM	
10	PAOZZ	5305008576886	80204	B1821BH038C450N	SCREW, CAP, HEXAGON H 3/8-16 X 4.50..	2
					UOC:A11, A24, A27, H11, H24, H27, MMM	
10	PAOZZ	5305014581670	80204	B1821BH038C550N	SCREW, CAP, HEXAGON H 3/8-16 X 5.50..	2
					UOC:B24	
11	PAOZZ	5310012057923	34623	5593213	WASHER, FLAT 3/8.....	30
					UOC:A11, A24, A27, B24, H11, H24, H27, MMM	
12	PAOZZ	5305008465703	80204	B1821BH038C300N	SCREW, CAP, HEXAGON H 3/8-16 X 3.00..	6
					UOC:A11, A24, A27, H11, H24, H27, MMM	
12	PAOZZ	5305007813928	80204	B1821BH038C400N	SCREW, CAP, HEXAGON H 3/8-16 X 4.00..	6
					UOC:B24	
13	PAOZZ	5305007829489	80204	B1821BH038C200N	SCREW, CAP, HEXAGON H 3/8-16 X 2.00..	1
					UOC:A11, A24, A27, B24, H11, H24, H27, MMM	
14	PAOZZ	2590011899747	19207	12339690	PAN, MOUNTING, TOW.....	1
					UOC:A11, A24, A27, B24, H11, H24, H27, MMM	
15	XAOZZ		19207	12339689	. PAN ASSEMBLY.....	1
					UOC:A11, A24, A27, B24, H11, H24, H27, MMM	
16	PAOZZ	5340011982253	31272	45053-11	. STRAP, WEBBING.....	4
					UOC:A11, A24, A27, B24, H11, H24, H27, MMM	
17	PAOZZ	5310009359021	96906	MS51943-35	NUT, SELF-LOCKING, HE 3/8-16.....	14
					UOC:A11, A24, A27, B24, H11, H24, H27, MMM	
18	PAOZZ	5310000614650	96906	MS51943-31	NUT, SELF-LOCKING, HE 1/4-20.....	2
					UOC:A11, A24, A27, B24, H11, H24, H27, MMM	
19	PAOZZ	5310013887420	25472	S4P90	NUT, PLAIN, BLIND RIV #4-20.....	2
					UOC:A11, A24, A27, B24, H11, H24, H27, MMM	
20	PAOZZ	5895010502072	19207	12265594	PANEL, INDICATOR.....	1
					UOC:A11, A24, A27, B24, H11, H24, H27, MMM	
21	PAOZZ	5310009501310	96906	MS27183-4	WASHER, FLAT #4.....	2
					UOC:A11, A24, A27, B24, H11, H24, H27, MMM	
22	PAOZZ	5305012554950	34623	MS-00034206-221	SCREW, MACHINE #4-40 X 1.00.....	2
					UOC:A11, A24, A27, B24, H11, H24, H27, MMM	



SECTION II			TM9-2320-280-24P			
(1)	(2)	(3)	(4)	(5)	(6)	(7)
ITEM	SMR			PART		
NO	CODE	NSN	CAGEC	NUMBER	DESCRIPTION AND USABLE ON CODES(UC)	QTY
23	PAOZZ	5305007813928	80204	B1821BH038C400N	SCREW,CAP,HEXAGON H 3/8-16 X 4.00.. UC:A11,A24,A27,H11,H24,H27,MMM	1
23	PAOZZ	5305014581670	80204	B1821BH038C550N	SCREW,CAP,HEXAGON H 3/8-16 X 5.50.. UC:B24	1
24	PFOZZ	2590011899736	19207	12339679-1	PEDESTAL ASSEMBLY,T..... UC:A11,A24,A27,B24,H11,H24,H27,MMM	1
25	PAOZZ	5305007813926	80204	B1821BH038C275N	SCREW,CAP,HEXAGON H 3/8-24 X 2.75.. UC:A11,A24,A27,H11,H24,H27,MMM	1
25	PAOZZ	5305009908632	80204	B1821BH038C375N	SCREW,CAP,HEXAGON H 3/8-16 X 3.75.. UC:B24	1
26	PAOZZ	5305007252317	80204	B1821BH038C150N	SCREW,CAP,HEXAGON H 3/8-16 X 1.50.. UC:A11,A24,A25,A26,A27,B17,B18,H11, H17,H18,H24,H25,H26,H27,MMM	1
26	PAOZZ	5305005432866	80204	B1821BH038C250N	SCREW,CAP,HEXAGON H 3/8-16 X 2.50.. UC:B24	1
27	PAOZZ	5305000680510	80204	B1821BH038C100N	SCREW,CAP,HEXAGON H 3/8-16 X 1.00.. UC:A11,A24,A27,B24,H11,H24,H27,MMM	2
28	PAOZZ	5305000581082	96906	MS51861-34	SCREW,TAPPING #8-18 X 3/8..... UC:A11,A24,A27,B24,H11,H24,H27,MMM	1
29	PAOZZ	5340012038674	19207	12340097	BUMPER, NONMETALLIC..... UC:A11,A24,A27,B24,H11,H24,H27,MMM	1
30	PAOZZ	5320012214231	11815	SSP-43	RIVET,BLIND 1/8 DIA..... UC:A11,A24,A27,B24,H11,H24,H27,MMM	2
31	PAOZZ	5340012115083	34623	5584765	BRACKET,ANGLE..... UC:A11,A24,A27,B24,H11,H24,H27,MMM	1

END OF FIGURE

USE WITH BASIC AND A1 VEHICLES

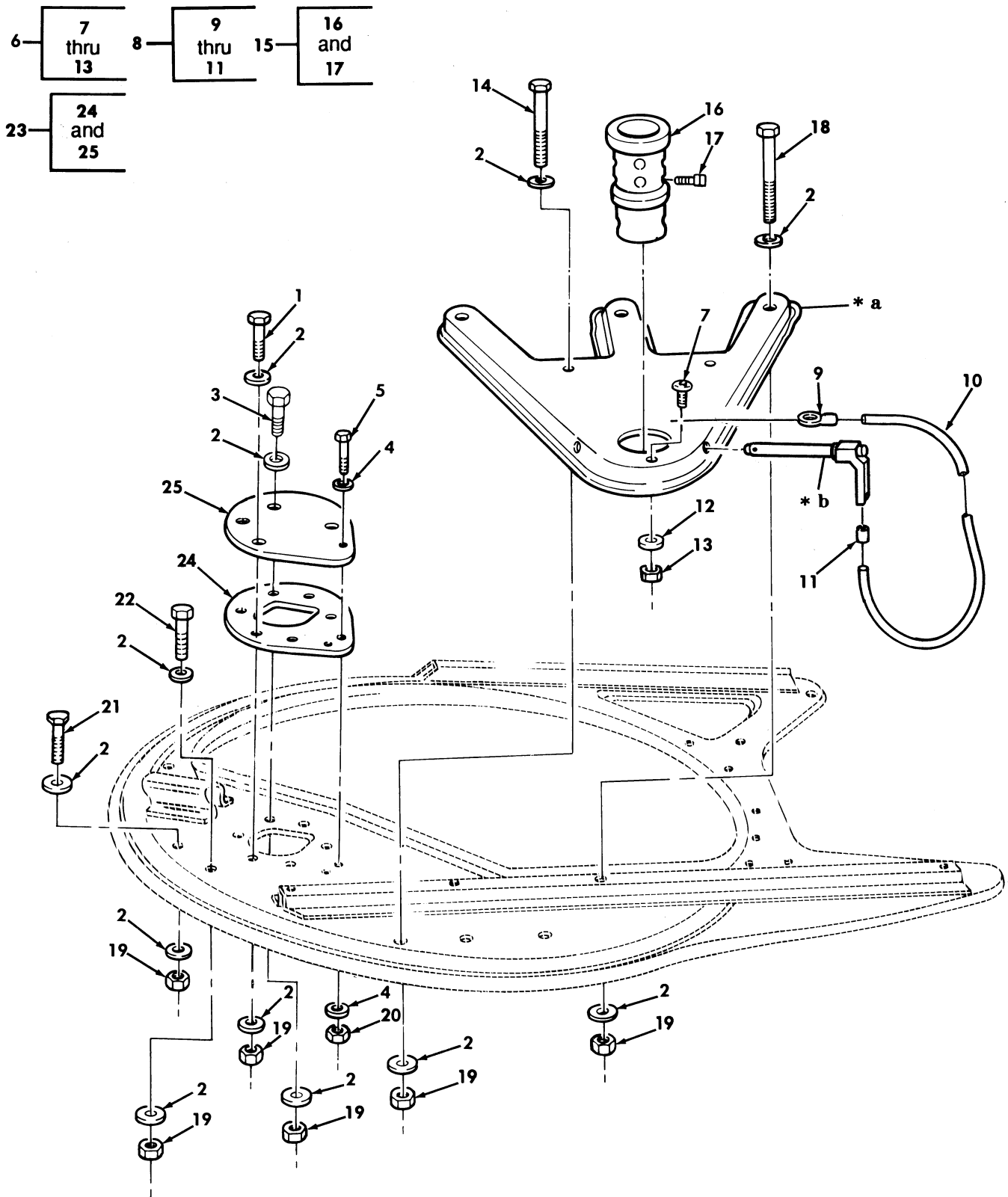

\* a PART OF ITEM 6  
\* b PART OF ITEM 8

Figure 275. Armament Pintle and Panel Assemblies, and Related Parts.

SECTION II			TM9-2320-280-24P			
(1)	(2)	(3)	(4)	(5)	(6)	(7)
ITEM NO	SMR CODE	NSN	CAGEC	PART NUMBER	DESCRIPTION AND USABLE ON CODES(UOC)	QTY
GROUP 1812 SPECIAL PURPOSE BODIES						
FIG. 275 ARMAMENT PINTLE AND PANEL ASSEMBLIES,AND RELATED PARTS						
1	PAOZZ	5305000680510	80204	B1821BH038C100N	SCREW,CAP,HEXAGON H 3/8-16 X 1.00..	1
					UOC:A25,A26,B17,B18,H17,H18,H25,H26	
2	PAOZZ	5310012057923	34623	5593213	WASHER,FLAT 3/8.....	22
					UOC:A25,A26,B17,B18,H17,H18,H25,H26	
3	PAOZZ	5305007813926	80204	B1821BH038C275N	SCREW,CAP,HEXAGON H 3/8-16 X 2.75..	2
					UOC:A25,A26,B17,B18,H17,H18,H25,H26	
4	PAOZZ	5310011023270	24617	2436161	WASHER,FLAT 1/4.....	2
					UOC:A25,A26,B17,B18,H17,H18,H25,H26	
5	PAOZZ	5305000680508	80204	B1821BH025C075N	SCREW,CAP,HEXAGON H 1/4-20 X 3/4...	1
					UOC:A25,A26,B17,B18,H17,H18,H25,H26	
6	PAOZZ		19207	12340349	PANEL ASSEMBLY,ARMA.....	1
					UOC:A25,A26,B17,B18,H17,H18,H25,H26	
7	PAOZZ	5305009846195	96906	MS35206-247	.SCREW,MACHINE #8-32 X 3/4.....	1
					UOC:A25,A26,B17,B18,H17,H18,H25,H26	
8	PAOOO	5315011977563	09094	QRP3C0855	.PIN,QUICK RELEASE.....	1
					UOC:A25,A26,B17,B18,H17,H18,H25,H26	
9	PAOZZ	4030001329181	96906	MS20668-4	..TERMINAL,ROPE,SWAGI.....	1
					UOC:A25,A26,B17,B18,H17,H18,H25,H26	
10	MOOZZ		81349	MIL-W-83420/14IN	..ROPE,WIRE MAKE FROM ROPE,WIRE,P/N MIL-W-83420/2-002, 14 INCHES LONG...	1
					UOC:A25,A26,B17,B18,H17,H18,H25,H26	
11	PAOZZ	4030006413921	81205	BACT14A6	..SWAGING SLEEVE,AIRC.....	1
					UOC:A25,A26,B17,B18,H17,H18,H25,H26	
12	PAOZZ	5310012531618	96906	MS51412-18	.WASHER,FLAT #8.....	1
					UOC:A25,A26,B17,B18,H17,H18,H25,H26	
13	PAOZZ	5310008071466	96906	MS21042-08	.NUT,SELF-LOCKING,EX #8-32.....	1
					UOC:A25,A26,B17,B18,H17,H18,H25,H26	
14	PAOZZ	5305007813930	80204	B1821BH038C475N	SCREW,CAP,HEXAGON H 3/8-16 X 4.75..	2
					UOC:A25,A26,B17,B18,H17,H18,H25,H26	
15	PAOZZ	3120011885082	19207	12340310	BEARING,SLEEVE.....	1
					UOC:A25,A26,B17,B18,H17,H18,H25,H26	
16	XAOZZ		19207	12340310-1	.ADAPTER,PINTLE.....	1
					UOC:A25,A26,B17,B18,H17,H18,H25,H26	
17	PAOZZ	5305012044190	7X677	9428747	.SETSCREW 3/8-24 X 1.00.....	4
					UOC:A25,A26,B17,B18,H17,H18,H25,H26	
18	PAOZZ	5305014460767	80204	B1821BH038C575N	SCREW,CAP,HEXAGON H 3/8-16 X 5.75..	4
					UOC:A25,A26,B17,B18,H17,H18,H25,H26	
19	PAOZZ	5310009359021	96906	MS51943-35	NUT,SELF-LOCKING,HE 3/8-16.....	11
					UOC:A25,A26,B17,B18,H17,H18,H25,H26	
20	PAOZZ	5310000614650	96906	MS51943-31	NUT,SELF-LOCKING,HE 1/4-20.....	1
					UOC:A25,A26,B17,B18,H17,H18,H25,H26	
21	PAOZZ	5305005432866	80204	B1821BH038C250N	SCREW,CAP,HEXAGON H 3/8-16 X 2.50..	1
					UOC:A25,A26,B17,B18,H17,H18,H25,H26	
22	PAOZZ	5305007252317	80204	B1821BH038C150N	SCREW,CAP,HEXAGON H 3/8-16 X 1.50..	1
					UOC:A25,A26,B17,B18,H17,H18,H25,H26	
23	PFOZZ	5342012680921	34623	55939274	COVER,SPECIAL SUPPLEMENTAL ARMOR...	1
					UOC:A25,A26,B17,B18,H17,H18,H25,H26	
24	PAOZZ	5330012383217	19207	12340095	.GASKET ARMAMENT COVER.....	1

SECTION II			TM9-2320-280-24P			
(1)	(2)	(3)	(4)	(5)	(6)	(7)
ITEM	SMR			PART		
NO	CODE	NSN	CAGEC	NUMBER	DESCRIPTION AND USABLE ON CODES(UC)	QTY
25	PFOZZ	5340012491587	19207	12340087	UC:A25,A26,B17,B18,H17,H18,H25,H26 .COVER,ACCESS.....	1
					UC:A25,A26,B17,B18,H17,H18,H25,H26	

END OF FIGURE

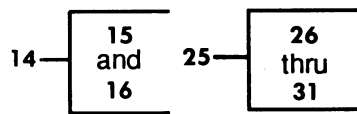

**USE WITH A2 VEHICLES**

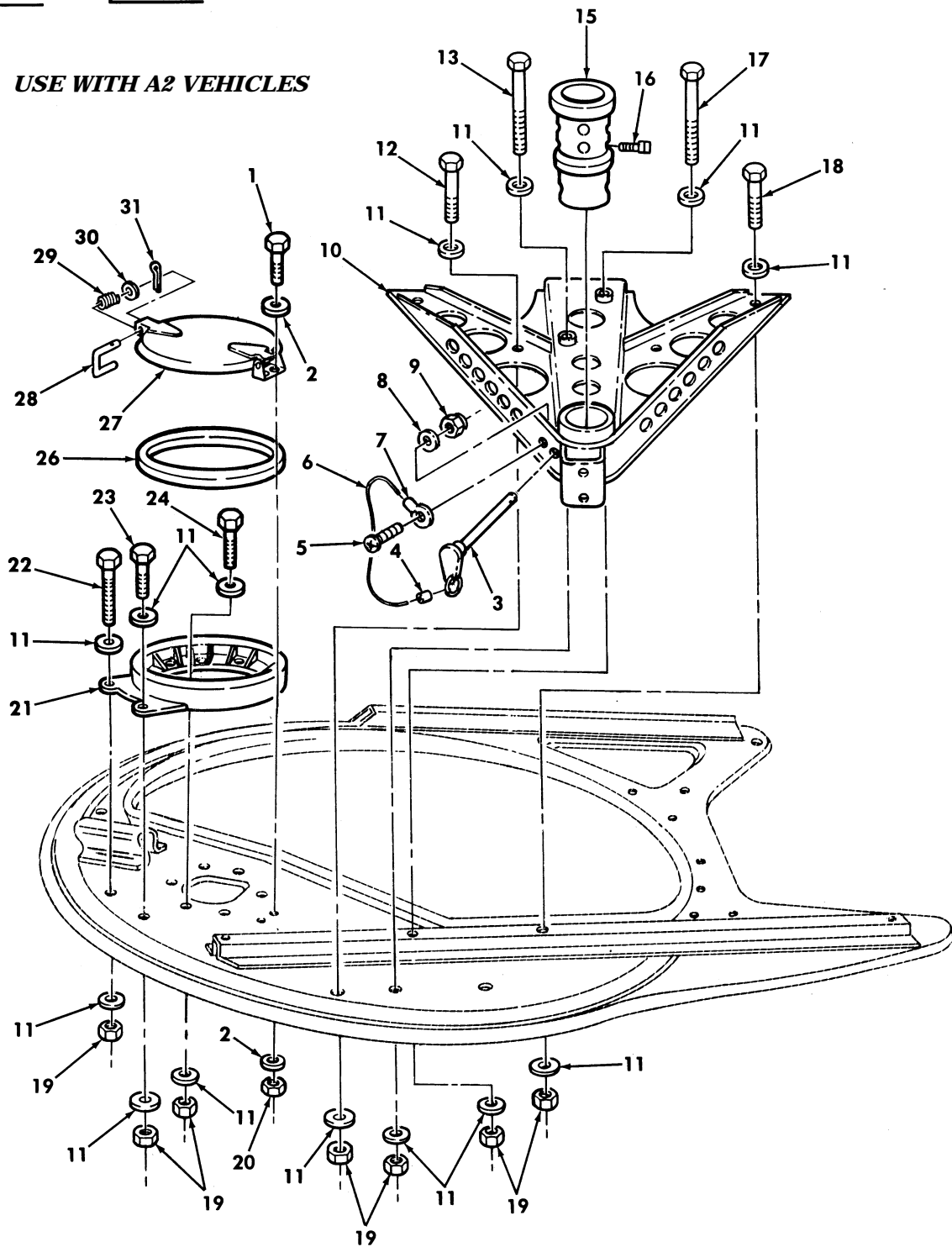

Figure 276. Armament Pintle and Panel Assemblies, and Related Parts.

SECTION II			TM9-2320-280-24P			
(1)	(2)	(3)	(4)	(5)	(6)	(7)
ITEM NO	SMR CODE	NSN	CAGEC	PART NUMBER	DESCRIPTION AND USABLE ON CODES(UOC)	QTY
GROUP 1812 SPECIAL PURPOSE BODIES						
FIG. 276 ARMAMENT PINTLE AND PANEL ASSEMBLIES,AND RELATED PARTS						
1	PAOZZ	5305000687837	80204	B1821BH025C063N	SCREW,CAP,HEXAGON H 1/4-20 X 5/8... UOC:B25,C17	4
2	PAOZZ	5310011023270	24617	2436161	WASHER,FLAT 1/4..... UOC:B25,C17	4
3	PAOOO	5315001502793	96906	MS17986-C840	PIN,QUICK RELEASE..... UOC:B25,C17	1
4	PAOZZ	4030011420456	96906	MS51844-63	SWAGING SLEEVE,WIRE..... UOC:B25,C17	1
5	PAOZZ	5305007542137	24617	159658	SCREW,MACHINE #8-32 X 3/4..... UOC:B25,C17	1
6	MOOZZ		81349	MIL-W-83420/14	ROPE,WIRE MAKE FROM ROPE,WIRE,P/N MIL-W-83420/2-002,14 INCHES LONG.... UOC:B25,C17	1
7	PAOZZ	4030001329181	96906	MS20668-4	TERMINAL,WIRE ROPE..... UOC:B25,C17	1
8	PAOZZ	5310012531618	96906	MS51412-18	WASHER,FLAT #8..... UOC:B25,C17	1
9	PAOZZ	5310008071466	96906	MS21042-08	NUT,SELF-LOCKING,HE #8-32..... UOC:B25,C17	1
10	PAOZZ	2590011887386	19207	12460206	PANEL ASSEMBLY,ARMA..... UOC:B25,C17	1
11	PAOZZ	5310012057923	34623	5593213	WASHER,FLAT 3/8..... UOC:B25,C17	28
12	PAOZZ	5305008576886	80204	B1821BH038C450N	SCREW,CAP,HEXAGON H 3/8-16 X 4.50.. UOC:B25,C17	1
13	PAOZZ		80204	B1821BH038C700N	SCREW,CAP,HEXAGON H 3/8-16 X 7.00.. UOC:B25,C17	1
14	PAOZZ	3120011885082	19207	12340310	BEARING,SLEEVE..... UOC:B25,C17	1
15	XAOZZ		19207	12340310-1	.ADAPTER,PINTAL..... UOC:B25,C17	1
16	PAOZZ	5305012044190	7X677	9428747	.SETSCREW 3/8-24..... UOC:B25,C17	1
17	PFOZZ		80204	B1821BH038C750N	SCREW,CAP,HEXAGON H 3/8-16 X 7.50.. UOC:B25,C17	1
18	PAOZZ	5305014581670	80204	B1821BH038C550N	SCREW,CAP,HEXAGON H 3/8-16 X 5.50.. UOC:B25,C17	3
19	PAOZZ	5310009359021	96906	MS51943-35	NUT,SELF-LOCKING,HE 3/8-16..... UOC:B25,C17	14
20	PAOZZ	5310000614650	96906	MS51943-31	NUT,SELF-LOCKING,HE 1/4-20..... UOC:B25,C17	2
21	PAOZZ	2590011899736	19207	12339679-1	PEDESTAL ASSEMBLY,T..... UOC:B25,C17	1
22	PAOZZ	5305009908632	80204	B1821BH038C375N	SCREW,CAP,HEXAGON H 3/8-16 X 3.75.. UOC:B25,C17	5
23	PAOZZ	5305005432866	80204	B1821BH038C250N	SCREW,CAP,HEXAGON H 3/8-16 X 2.50.. UOC:B25,C17	1
24	PAOZZ	5305000680510	80204	B1821BH038C100N	SCREW,CAP,HEXAGON H 3/8-16 X 1.00.. UOC:B25,C17	2

SECTION II			TM9-2320-280-24P			
(1)	(2)	(3)	(4)	(5)	(6)	(7)
ITEM	SMR			PART		
NO	CODE	NSN	CAGEC	NUMBER	DESCRIPTION AND USABLE ON CODES(UC)	QTY
					UOC:B25,C17	
25	PAOZZ	2510011899828	19207	12340311	DOOR,HATCH,VEHICLE.....	1
					UOC:B25,C17	
26	PAOZZ	5330012701353	19207	12340117	.SEAL.....	1
					UOC:B25,C17	
27	PAOZZ	2510013102324	34623	5582436	.COVER.....	1
					UOC:B25,C17	
28	PAOZZ	2510012573747	19207	12340104	.ROD,HOOD,VEHICULAR.....	1
					UOC:B25,C17	
29	PAOZZ	5360009028068	96906	MS24585-281	.SPRING,HELICAL,COM.....	1
					UOC:B25,C17	
30	PAOZZ	5310011023270	24617	2436161	.WASHER,FLAT 1/4.....	1
					UOC:B25,C17	
31	PAOZZ	5315008392326	96906	MS24665-281	.PIN,COTTER 3/32 X 1/2.....	1
					UOC:B25,C17	

END OF FIGURE

Section II.

TM 9-2320-280-24P-1

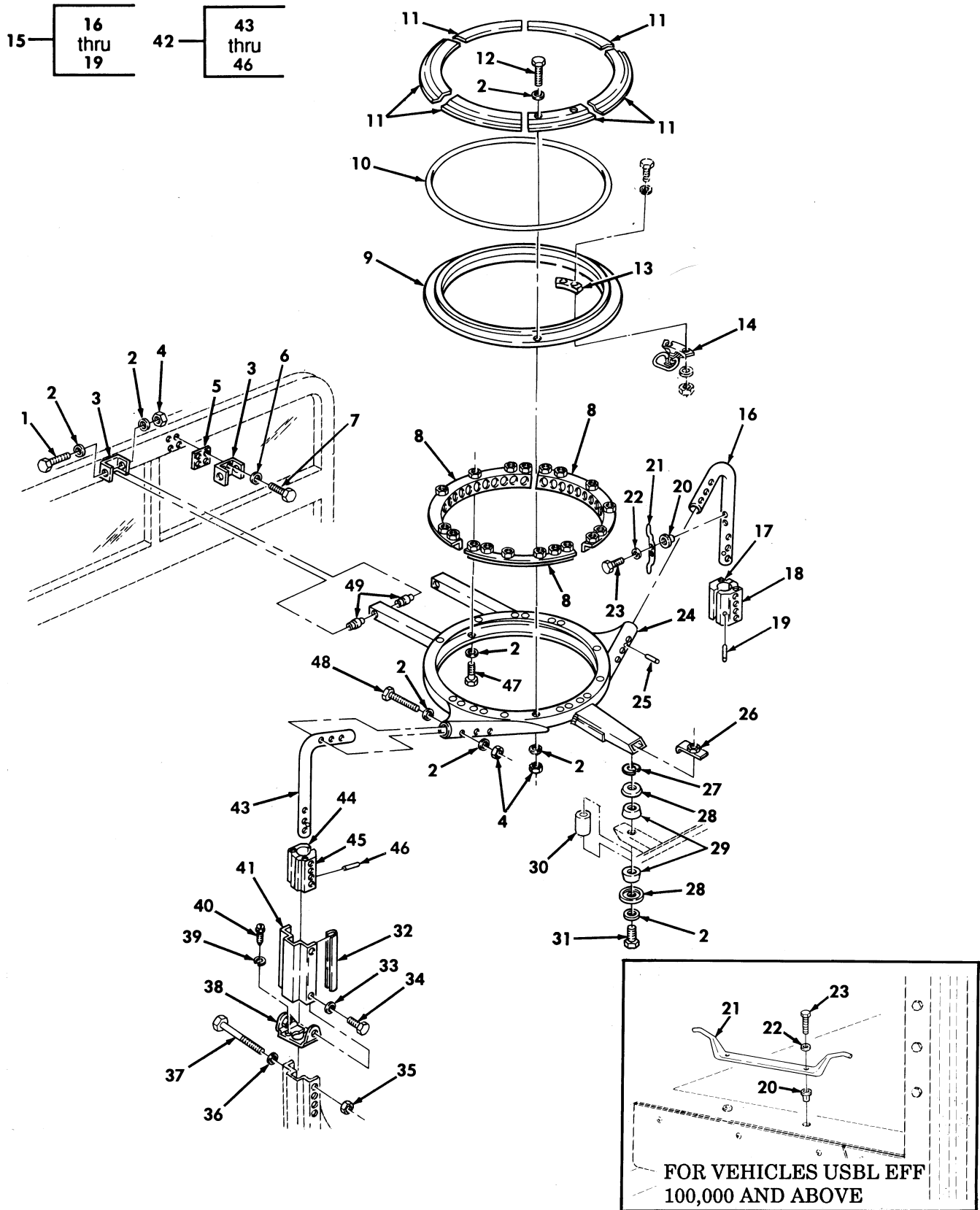

Figure 277. Turret Support Ring Assembly.



SECTION II			TM9-2320-280-24P			
(1)	(2)	(3)	(4)	(5)	(6)	(7)
ITEM	SMR			PART		
NO	CODE	NSN	CAGEC	NUMBER	DESCRIPTION AND USABLE ON CODES(UOC)	QTY
GROUP 1812 SPECIAL PURPOSE BODIES						
FIG. 277 TURRET SUPPORT RING ASSEMBLY						
1	PAOZZ	5305008576886	80204	B1821BH038C450N	SCREW,CAP,HEXAGON H 3/8-16 X 4.50.. UOC:A11,A24,A25,A26,A27,B17,B18,B24, B25,C17,H11,H17,H18,H24,H25,H26,H27, MMM	2
2	PAOZZ	5310000806004	96906	MS27183-14	WASHER,FLAT 3/8..... UOC:A11,A24,A25,A26,A27,B17,B18,B24, B25,C17,H11,H17,H18,H24,H25,H26,H27, MMM	47
3	PAFZZ	2510012526240	19207	12340116	FRAME SECTION,STRUC..... UOC:A11,A24,A25,A26,A27,B17,B18,B24, B25,C17,H11,H17,H18,H24,H25,H26,H27, MMM	2
4	PAOZZ	5310009359021	96906	MS51943-35	NUT,SELF-LOCKING,HE 3/8-16..... UOC:A11,A24,A25,A26,A27,B17,B18,B24, B25,C17,H11,H17,H18,H24,H25,H26,H27, MMM	20
5	PAFZZ	5365011954949	19207	12340099-1	SPACER,PLATE 0.125..... UOC:A11,A24,A25,A26,A27,B17,B18,B24, B25,C17,H11,H17,H18,H24,H25,H26,H27, MMM	2
5	PAFZZ	5365012554990	34623	5596642	SPACER,PLATE 0.030..... UOC:A11,A24,A25,A26,A27,B17,B18,B24, B25,C17,H11,H17,H18,H24,H25,H26,H27, MMM	2
5	PAFZZ	5365012554991	34623	5596643	SPACER,PLATE 0.060..... UOC:A11,A24,A25,A26,A27,B17,B18,B24, B25,C17,H11,H17,H18,H24,H25,H26,H27, MMM	2
5	PAFZZ	5365012554633	34623	5596644	SPACER,PLATE 0.090..... UOC:A11,A24,A25,A26,A27,B17,B18,B24, B25,C17,H11,H17,H18,H24,H25,H26,H27, MMM	2
5	PAFZZ	5365012554634	34623	5596645	SPACER,PLATE 0.190..... UOC:A11,A24,A25,A26,A27,B17,B18,B24, B25,C17,H11,H17,H18,H24,H25,H26,H27, MMM	2
6	PAFZZ	5310012520512	34623	5592832	WASHER,FLAT 5/16..... UOC:A11,A24,A25,A26,A27,B17,B18,B24, B25,C17,H11,H17,H18,H24,H25,H26,H27, MMM	8
7	PAFZZ	5306002264826	80204	B1821BH031C088N	BOLT,MACHINE 5/16-18 X 7/8..... UOC:A11,A24,A25,A26,A27,B17,B18,B24, B25,C17,H11,H17,H18,H24,H25,H26,H27, MMM	8
8	PAOZZ	2590011924525	19207	12340298	RING,TURRET LOCK..... UOC:A11,A24,A25,A26,A27,B17,B18,B24, B25,C17,H11,H17,H18,H24,H25,H26,H27, MMM	3

SECTION II			TM9-2320-280-24P			
(1)	(2)	(3)	(4)	(5)	(6)	(7)
ITEM NO	SMR CODE	NSN	CAGEC	PART NUMBER	DESCRIPTION AND USABLE ON CODES(UOC)	QTY
9	PAOZZ	3110011853114	19207	12340302	BEARING ASSEMBLY, TU..... UOC:A11, A24, A25, A26, A27, B17, B18, H11, H17, H18, H24, H25, H26, H27, MMM	1
9	PAOZZ	3110014579711	28666	T2H2-38P2	BEARING, ASSEMBLY, TU..... UOC:B24, B25, C17	1
10	PAOZZ	5330012822213	28666	MT161A	SEAL, NONMETALLIC SP..... UOC:A11, A24, A25, A26, A27, B17, B18, B24, B25, C17, H11, H17, H18, H24, H25, H26, H27, MMM	1
11	PAOZZ	2590011853112	19207	12340312	MOLDING, METAL..... UOC:A11, A24, A25, A26, A27, B17, B18, H11, H17, H18, H24, H25, H26, H27, MMM	6
11	PAOZZ	5340014575571	19207	12460290	BRACKET, DOUBLE ANGL..... UOC:B24, B25, C17	12
12	PAOZZ	5305007252317	80204	B1821BH038C150N	SCREW, CAP, HEXAGON H 3/8-16 X 1.50.. UOC:A11, A24, A25, A26, A27, B17, B18, H11, H17, H18, H24, H25, H26, H27, MMM	12
12	PAOZZ	5305007813926	80204	B1821BH038C275N	SCREW, CAP, HEXAGON H 3/8-16 X 2.75.. UOC:B24, B25, C17	12
13	PFFZZ	5365012544394	19207	12340115-1	SPACER, PLATE 0.050 INCHES THICK.... UOC:A11, A24, A25, A26, A27, B17, B18, B24, B25, C17, H11, H17, H18, H24, H25, H26, H27, MMM	1
13	PFFZZ	5365014573364	19207	12340115-2	SPACER, PLATE 0.160 INCHES THICK.... UOC:A11, A24, A25, A26, A27, B17, B18, B24, B25, C17, H11, H17, H18, H24, H25, H26, H27, MMM	1
14	PAOZZ	5340012538933	31272	45460-10	LOCK SET, RIM..... UOC:A11, A24, A25, A26, A27, B17, B18, B24, B25, C17, H11, H17, H18, H24, H25, H26, H27, MMM	1
15	PFFFF	4710011929720	19207	12340342-2	TUBE, BENT, METALLIC R.H., USBL EFF 1 THRU 99, 999..... UOC:H11, H17, H18, H24, H25, H26, H27, MMM	1
15	PFFFF	4710013357523	19207	12340342-6	TUBE, BENT, METALLIC R.H., USBL EFF 100,000 AND ABOVE..... UOC:A11, A24, A25, A26, A27, B17, B18, B24, B25, C17, H11, H17, H18, H24, H25, H26, H27, MMM	1
16	XAFZZ		19207	12340342-4	.SUPPORT UPPER B PILLAR, RIGHT HAND. UOC:A11, A24, A25, A26, A27, B17, B18, B24, B25, C17, H11, H17, H18, H24, H25, H26, H27, MMM	1
17	PFFZZ	2510012571572	19207	12340090-1	.FRAME SECTION, STRUC B PILLAR FRONT UOC:A11, A24, A25, A26, A27, B17, B18, B24, B25, C17, H11, H17, H18, H24, H25, H26, H27, MMM	1
18	PFFZZ	2510012668013	19207	12340090-2	.FRAME SECTION, STRUC B PILLAR REAR. UOC:A11, A24, A25, A26, A27, B17, B18, B24, B25, C17, H11, H17, H18, H24, H25, H26, H27, MMM	1
19	PAFZZ	5315011733397	24617	9412281	.PIN, SPRING..... UOC:A11, A24, A25, A26, A27, B17, B18, B24,	2

SECTION II			TM9-2320-280-24P			
(1)	(2)	(3)	(4)	(5)	(6)	(7)
ITEM NO	SMR CODE	NSN	CAGEC	PART NUMBER	DESCRIPTION AND USABLE ON CODES(UOC)	QTY
20	PAOZZ	4931012028692	19207	12339998-13	B25,C17,H11,H17,H18,H24,H25,H26,H27, MMM PLUSNUT 1/4-20..... UOC:A11,A24,A25,A26,A27,B17,B18,B24, B25,C17,H11,H17,H18,H24,H25,H26,H27, MMM	2
21	PFOZZ	2540011929718	19207	12340301	CLEAT,STOWAGE,CABLE..... UOC:A11,A24,A25,A26,A27,B17,B18,B24, B25,C17,H11,H17,H18,H24,H25,H26,H27, MMM	1
22	PAOZZ	5310011023270	24617	2436161	WASHER,FLAT 1/4..... UOC:A11,A24,A25,A26,A27,B17,B18,B24, B25,C17,H11,H17,H18,H24,H25,H26,H27, MMM	2
23	PAOZZ	5305002253843	80204	B1821BH025C100N	SCREW,CAP,HEXAGON H 1/4-20 X 1.00.. UOC:A11,A24,A25,A26,A27,B17,B18,B24, B25,C17,H11,H17,H18,H24,H25,H26,H27, MMM	2
24	PFFZZ	2540011853113	19207	12340334	SUPPORT ASSEMBLY,WE..... UOC:A11,A24,A25,A26,A27,B17,B18,B24, B25,C17,H11,H17,H18,H24,H25,H26,H27, MMM	1
25	PAFZZ	5315011960277	7X677	456369	PIN,SPRING 1/4 X 1/2..... UOC:A11,A24,A25,A26,A27,B17,B18,B24, B25,C17,H11,H17,H18,H24,H25,H26,H27, MMM	2
26	PFFZZ	2540011940197	19207	12339562	PLATE ASSEMBLY,ROOF REAR SUPPORT MOUNT..... UOC:A11,A24,A25,A26,A27,B17,B18,B24, B25,C17,H11,H17,H18,H24,H25,H26,H27, MMM	1
27	PAFZZ	5310012122303	34623	5591507	WASHER,SLOTTED..... V UOC:A11,A24,A25,A26,A27,B17,B18,B24, B25,C17,H11,H17,H18,H24,H25,H26,H27, MMM	
28	PFFZZ	2540011925949	19207	12339561	PLATE,SNUBBER,VEHIC REAR SUPPORT MOUNT..... UOC:A11,A24,A25,A26,A27,B17,B18,B24, B25,C17,H11,H17,H18,H24,H25,H26,H27, MMM	2
29	PAFZZ	5340012110838	34623	5584891	MOUNT,RESILIENT..... UOC:A11,A24,A25,A26,A27,B17,B18,B24, B25,C17,H11,H17,H18,H24,H25,H26,H27, MMM	2
30	PFFZZ	5365012160364	19207	12338186-52	SPACER,SLEEVE .407 ID X .625 OD X 2.250 LONG..... UOC:A11,A24,A25,A26,A27,B17,B18,B24, B25,C17,H11,H17,H18,H24,H25,H26,H27, MMM	1
31	PAFZZ	5305007813927	80204	B1821BH038C350N	SCREW,CAP,HEXAGON H 3/8-16 X 3.50 USE W/0-2 SHIMS..... UOC:A11,A24,A25,A26,A27,B17,B18,B24, B25,C17,H11,H17,H18,H24,H25,H26,H27,	1

SECTION II			TM9-2320-280-24P			
(1)	(2)	(3)	(4)	(5)	(6)	(7)
ITEM	SMR			PART		
NO	CODE	NSN	CAGEC	NUMBER	DESCRIPTION AND USABLE ON CODES(UC)	QTY
31	PAFZZ	5305009908632	80204	B1821BH038C375N	MMM SCREW,CAP,HEXAGON H 3/8-16 X 3.75 USE W/3-5 SHIMS..... UOC:A11,A24,A25,A26,A27,B17,B18,B24, B25,C17,H11,H17,H18,H24,H25,H26,H27, MMM	1
31	PAFZZ	5305007813928	80204	B1821BH038C400N	SCREW,CAP,HEXAGON H 3/8-16 X 4.00 USE W/6-7 SHIMS..... UOC:A11,A24,A25,A26,A27,B17,B18,B24, B25,C17,H11,H17,H18,H24,H25,H26,H27, MMM	1
32	PAOZZ	2590014608320	19207	12340103-3	BEZEL,AUTOMOTIVE TR LEFT 11.13" LONG..... UOC:A11,A24,A25,A26,A27,B17,B18,B24, B25,C17,H11,H17,H18,H24,H25,H26,H27, MMM	2
32	PAOZZ	2590014579922	19207	12340103-4	BEZEL,AUTOMOTIVE TR RIGHT 8.25" LONG..... UOC:A11,A24,A25,A26,A27,B17,B18,B24, B25,C17,H11,H17,H18,H24,H25,H26,H27, MMM	2
33	PAFZZ	5310000814219	96906	MS27183-12	WASHER,FLAT 5/16..... UOC:A11,A24,A25,A26,A27,B17,B18,B24, B25,C17,H11,H17,H18,H24,H25,H26,H27, MMM	6
34	PAFZZ	5305009845675	96906	MS35206-295	SCREW,MACHINE 5/16-18 X 5/8..... UOC:A11,A24,A25,A26,A27,B17,B18,B24, B25,C17,H11,H17,H18,H24,H25,H26,H27, MMM	6
35	PAFZZ	5310002416658	96906	MS51943-34	NUT,SELF-LOCKING,HE 5/16-24..... UOC:A11,A24,A25,A26,A27,B17,B18,B24, B25,C17,H11,H17,H18,H24,H25,H26,H27, MMM	8
36	PAFZZ	5310011946459	19207	12339724	WASHER,FLAT 5/16..... UOC:A11,A24,A25,A26,A27,B17,B18,B24, B25,C17,H11,H17,H18,H24,H25,H26,H27, MMM	8
37	PAFZZ	5306002928253	88044	AN5H41	BOLT,MACHINE 5/16-24 X 4.21..... UOC:A11,A24,A25,A26,A27,B17,B18,B24, B25,C17,H11,H17,H18,H24,H25,H26,H27, MMM	8
38	PFFZZ	5340011960572	34623	5584032	BRACKET,MOUNTING..... UOC:A11,A24,A25,A26,A27,B17,B18,B24, B25,C17,H11,H17,H18,H24,H25,H26,H27, MMM	2
39	PAFZZ	5310005845272	02978	ERNA245	WASHER,LOCK #10..... UOC:A11,A24,A25,A26,A27,B17,B18,B24, B25,C17,H11,H17,H18,H24,H25,H26,H27, MMM	4
40	PAFZZ	5305008550957	80205	MS24629-46	SCREW,TAPPING #10-32 X 1/2..... UOC:A11,A24,A25,A26,A27,B17,B18,B24, B25,C17,H11,H17,H18,H24,H25,H26,H27, MMM	4

SECTION II			TM9-2320-280-24P			
(1)	(2)	(3)	(4)	(5)	(6)	(7)
ITEM NO	SMR CODE	NSN	CAGEC	PART NUMBER	DESCRIPTION AND USABLE ON CODES(UC)	QTY
41	PFFZZ	2540011925937	19207	12340338	COVER,PILLAR..... UOC:A11,A24,A25,A26,A27,B17,B18,B24, B25,C17,H11,H17,H18,H24,H25,H26,H27, MMM	2
42	PFFZZ	4710013335995	19207	12340342-5	TUBE,BENT,METALLIC L.H.,USBL EFF 100,000 AND ABOVE..... UOC:A11,A24,A25,A26,A27,B17,B18,B24, B25,C17,H11,H17,H18,H24,H25,H26,H27, MMM	1
42	PFFZZ	4710011926113	34623	5578481	TUBE ASSEMBLY,METAL UPPER B PILLAR L.H.,USBL EFF 1 THRU 99,999..... UOC:A11,A24,A25,A26,A27,B17,B18,B24, B25,C17,H11,H17,H18,H24,H25,H26,H27, MMM	1
43	XAFZZ		19207	12340342-3	.SUPPORT UPPER B PILLAR,L.H..... UOC:A11,A24,A25,A26,A27,B17,B18,B24, B25,C17,H11,H17,H18,H24,H25,H26,H27, MMM	1
44	PFFZZ	2510012668013	19207	12340090-2	.FRAME SECTION,STRUC B PILLAR REAR. UOC:A11,A24,A25,A26,A27,B17,B18,B24, B25,C17,H11,H17,H18,H24,H25,H26,H27, MMM	1
45	PFFZZ	2510012571572	19207	12340090-1	.FRAME SECTION,STRUC B PILLAR FRONT UOC:A11,A24,A25,A26,A27,B17,B18,B24, B25,C17,H11,H17,H18,H24,H25,H26,H27, MMM	1
46	PAFZZ	5315011733397	24617	9412281	.PIN,SPRING..... UOC:A11,A24,A25,A26,A27,B17,B18,B24, B25,C17,H11,H17,H18,H24,H25,H26,H27, MMM	2
47	PAOZZ	5305000680510	80204	B1821BH038C100N	SCREW,CAP,HEXAGON H 3/8-16 X 1.00.. UOC:A11,A24,A25,A26,A27,B17,B18,B24, B25,C17,H11,H17,H18,H24,H25,H26,H27, MMM	18
48	PAFZZ	5305008465703	80204	B1821BH038C300N	SCREW,CAP,HEXAGON H 3/8-16 X 3.00.. UOC:A11,A24,A25,A26,A27,B17,B18,B24, B25,C17,H11,H17,H18,H24,H25,H26,H27, MMM	6
49	PAFZZ	5340011976755	96867	3541	MOUNT,RESILIENT FRONT SUPPORT, MOUNTING CLEVIS..... UOC:A11,A24,A25,A26,A27,B17,B18,B24, B25,C17,H11,H17,H18,H24,H25,H26,H27, MMM	4

END OF FIGURE

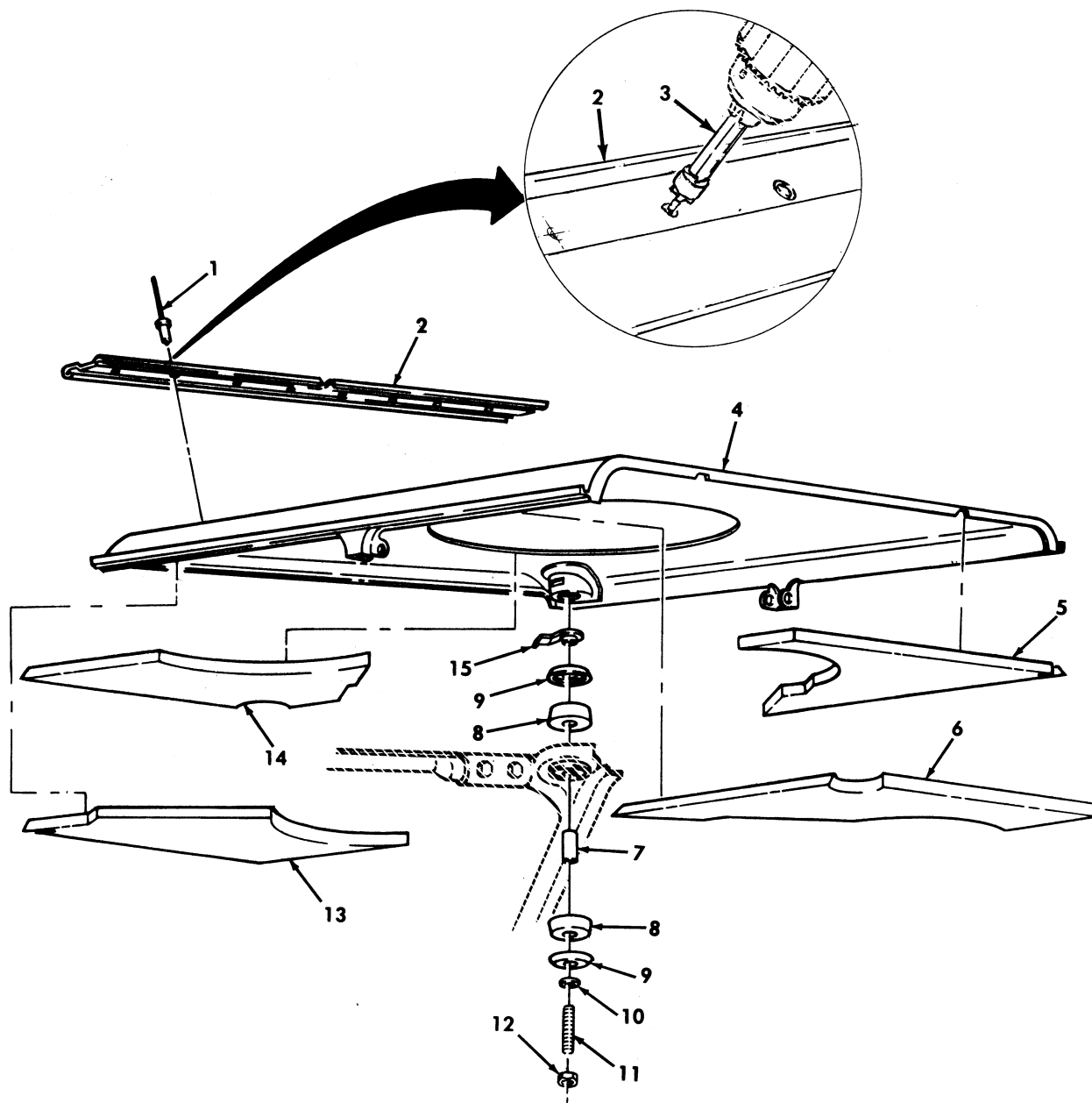

Figure 278. Roof and Mounting Components.

SECTION II			TM9-2320-280-24P			
(1)	(2)	(3)	(4)	(5)	(6)	(7)
ITEM	SMR			PART		
NO	CODE	NSN	CAGEC	NUMBER	DESCRIPTION AND USABLE ON CODES(UCO)	QTY
GROUP 1812 SPECIAL PURPOSE BODIES						
FIG. 278 ROOF AND MOUNTING COMPONENTS						
1	PAFZZ	5320011357319	80205	NAS9301BNS-6-03	RIVET,BLIND PART OF KIT P/N 57K0223.	28
2	PAFZA	5340014484316	19207	12339569	UOC:A11,A24,A27,B24,H11,H24,H27,MMM CLIP,SPRING TENSION BLAST SHIELD	1
3	KFFZZ		19207	12342805	UOC:A11,A24,A27,B24,H11,H24,H27,MMM PART OF KIT P/N 57K0223..... CUTTER,SPOTWELD PART OF KIT P/N	1
4	PAFZZ	2510012366488	34623	5595393	57K0223..... UOC:A11,A24,A27,B24,H11,H24,H27,MMM PANEL,BODY,VEHICULA SUPPLEMENTAL	1
4	PAFZZ	2510011873606	34623	12339623-1	ARMOR..... UOC:A25,A26,B25,H25,H26	1
4	PAFZZ	2510011929723	34623	12339623-3	PANEL,BODY,VEHICULA BASIC ARMOR....	1
4	PFFZZ	2540012366489	19207	12339631-2	UOC:B17,B18,C17,H17,H18 PANEL,BODY,VEHICULA BASIC ARMOR....	1
5	PAOZZ	2510012052507	19207	12339624-1	UOC:A11,H11,MMM PANEL ASSEMBLY,ROOF SUPPLEMENTAL	1
6	PAOZZ	2540012039872	19207	12339624-2	ARMOR..... UOC:A24,A27,B24,H24,H27	1
7	PFFZZ	5365012160364	19207	12338186-52	LINER,ROOF,VEHICULA REAR,L.H.....	1
8	PAFZZ	5340012110838	34623	5584891	UOC:A11,A24,A27,B17,B18,B24,C17,H11, H17,H18,H24,H27,MMM	1
9	PAFZZ	2540011925949	19207	12339561	INSULATION,THERMAL, REAR,R.H.....	1
10	PAFZZ	5310014124013	24617	2436163	UOC:A11,A24,A27,B17,B18,B24,C17,H11, H17,H18,H24,H27,MMM	5
11	PAFZZ	5307012542504	19207	12339559	SPACER,SLEEVE.....	8
12	PAFZZ	5310009359021	96906	MS51943-35	UOC:A11,A24,H11,H17,H18,H24,H25,H26, H27,MMM	8
13	PAOZZ	2590012052506	19207	12339626-1	MOUNT,RESILIENT.....	8
					UOC:A11,A24,A25,A26,A27,B17,B18,B24, B25,C17,H11,H17,H18,H24,H25,H26,H27, MMM	8
					PLATE,SNUBBER,VEHIC.....	8
					UOC:A11,A24,A25,A26,A27,B17,B18,B24, B25,C17,H11,H17,H18,H24,H25,H26,H27, MMM	4
					WASHER,FLAT 3/8.....	4
					UOC:A11,A24,A25,A26,A27,B17,B18,B24, B25,C17,H11,H17,H18,H24,H25,H26,H27, MMM	4
					STUD,PLAIN 3/8-16 X 3.75.....	4
					UOC:A11,A24,A25,A26,A27,B17,B18,B24, B25,C17,H11,H17,H18,H24,H25,H26,H27, MMM	4
					NUT,SELF-LOCKING,HE 3/8-16.....	4
					UOC:A11,A24,A25,A26,A27,B17,B18,B24, B25,C17,H11,H17,H18,H24,H25,H26,H27, MMM	1
					PANEL,ROOF,FRONT,L FRONT,L.H.....	1

SECTION II			TM9-2320-280-24P			
(1)	(2)	(3)	(4)	(5)	(6)	(7)
ITEM	SMR			PART		
NO	CODE	NSN	CAGEC	NUMBER	DESCRIPTION AND USABLE ON CODES(UC)	QTY
14	PAOZZ	2510012039873	34623	SF-5590748	UOC:A11,A24,A27,B17,B18,B24,C17,H11, H17,H18,H24,H27,MMM LINER,ROOF,VEHICULA FRONT,R.H..... UOC:A11,A24,A27,B17,B18,B24,C17,H11, H17,H18,H24,H27,MMM	1
15	PAFZZ	5340012039391	34623	5583231	BRACKET,DOUBLE ANGL..... UOC:A11,A24,A25,A26,A27,B17,B18,B24, B25,C17,H11,H17,H18,H24,H25,H26,H27, MMM	4

END OF FIGURE



1 — 2  
thru  
31

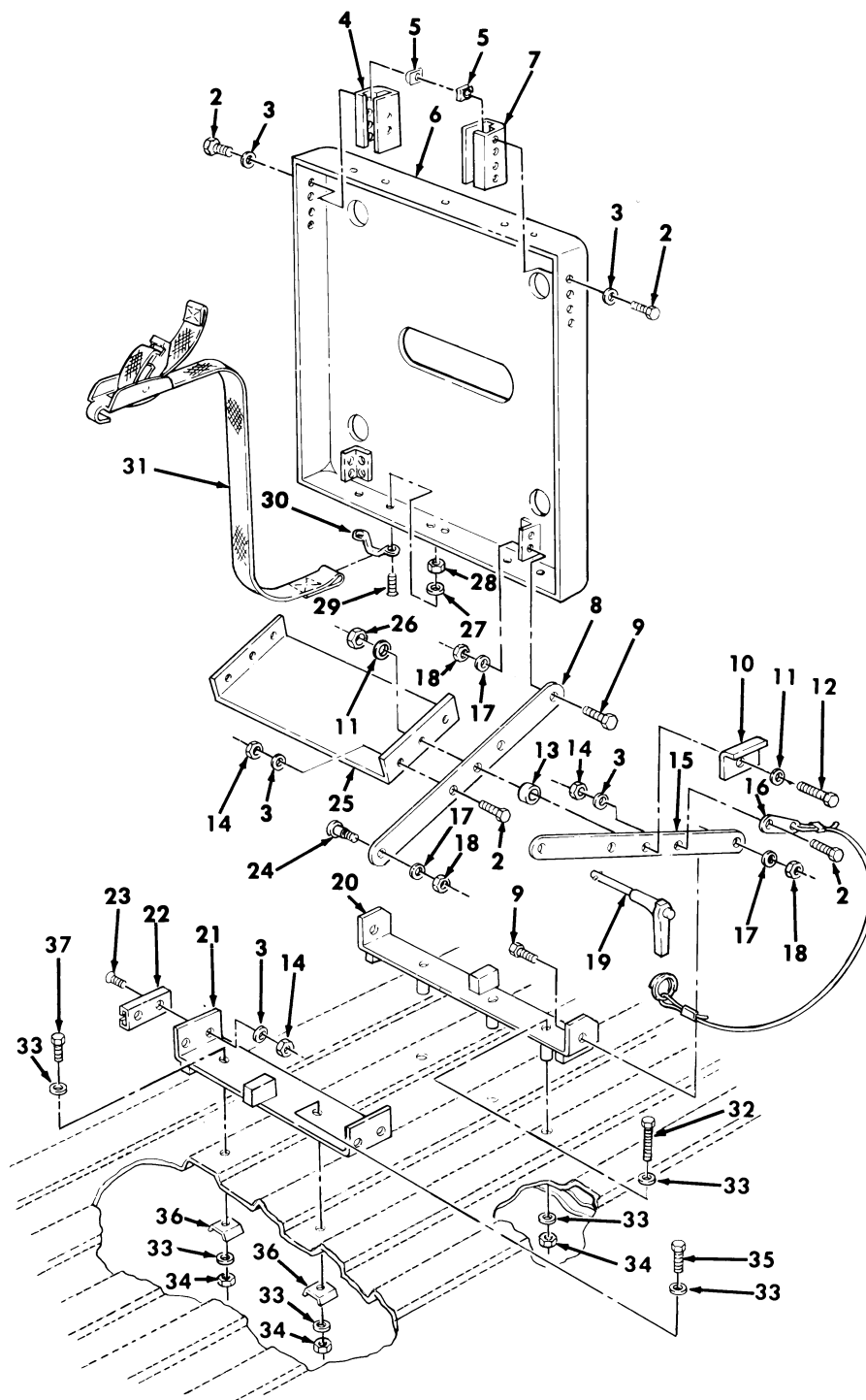

Figure 279. Gunner's Platform Assembly and Mounting Hardware.

SECTION II			TM9-2320-280-24P			
(1)	(2)	(3)	(4)	(5)	(6)	(7)
ITEM	SMR			PART		
NO	CODE	NSN	CAGEC	NUMBER	DESCRIPTION AND USABLE ON CODES(UOC)	QTY
GROUP 1812 SPECIAL PURPOSE BODIES						
FIG. 279 GUNNER'S PLATFORM ASSEMBLY AND MOUNTING HARDWARE						
1	PAOZZ	2540012491584	31272	45481-10	PLATFORM ASSEMBLY,..... UOC:A11,A24,A25,A26,A27,B17,B18,B24, B25,C17,H11,H17,H18,H24,H25,H26,H27, MMM	1
2	PAOZZ	5305002678953	80204	B1821BH025F063N	.SCREW,CAP,HEXAGON H 1/4-28 X 5/8.. UOC:A11,A24,A25,A26,A27,B17,B18,B24, B25,C17,H11,H17,H18,H24,H25,H26,H27, MMM	10
3	PAOZZ	5310001670835	88044	AN960-416L	.WASHER,FLAT 1/4..... UOC:A11,A24,A25,A26,A27,B17,B18,B24, B25,C17,H11,H17,H18,H24,H25,H26,H27, MMM	14
4	PFOZZ	2590012624980	31272	45602-11	.GUIDE,PLATFORM..... UOC:A11,A24,A25,A26,A27,B17,B18,B24, B25,C17,H11,H17,H18,H24,H25,H26,H27, MMM	1
5	PAOZZ	5310012984686	31272	45611-10	.NUT BLANK..... UOC:A11,A24,A25,A26,A27,B17,B18,B24, B25,C17,H11,H17,H18,H24,H25,H26,H27, MMM	4
6	PFOZZ	2590012600214	31272	45481-01	.PLATFORM ASSEMBLY,G..... UOC:A11,A24,A25,A26,A27,B17,B18,B24, B25,C17,H11,H17,H18,H24,H25,H26,H27, MMM	1
7	PFOZZ	2590012624981	31272	45602-10	.GUIDE,PLATFORM..... UOC:A11,A24,A25,A26,A27,B17,B18,B24, B25,C17,H11,H17,H18,H24,H25,H26,H27, MMM	1
8	PFOZZ	3040012649554	31272	45617-13	.CONNECTING LINK,RIG..... UOC:A11,A24,A25,A26,A27,B17,B18,B24, B25,C17,H11,H17,H18,H24,H25,H26,H27, MMM	2
9	PAOZZ	5306012696254	31272	45621-10	.BOLT,SHOULDER..... UOC:A11,A24,A25,A26,A27,B17,B18,B24, B25,C17,H11,H17,H18,H24,H25,H26,H27, MMM	4
10	PFOZZ	5342012600215	31272	45721-10	.LATCH,PLATFORM,GUNN..... UOC:A11,A24,A25,A26,A27,B17,B18,B24, B25,C17,H11,H17,H18,H24,H25,H26,H27, MMM	2
11	PAOZZ	5310001670837	88044	AN960-616L	.WASHER,FLAT..... UOC:A11,A24,A25,A26,A27,B17,B18,B24, B25,C17,H11,H17,H18,H24,H25,H26,H27, MMM	4
12	PAOZZ	5306002083639	88044	AN6-16A	.BOLT,MACHINE..... UOC:A11,A24,A25,A26,A27,B17,B18,B24, B25,C17,H11,H17,H18,H24,H25,H26,H27, MMM	2

SECTION II			TM9-2320-280-24P			
(1)	(2)	(3)	(4)	(5)	(6)	(7)
ITEM	SMR			PART		
NO	CODE	NSN	CAGEC	NUMBER	DESCRIPTION AND USABLE ON CODES(UC)	QTY
13	PAOZZ	5365012676769	31273	45613-10	. SPACER, SLEEVE..... UOC:A11, A24, A25, A26, A27, B17, B18, B24, B25, C17, H11, H17, H18, H24, H25, H26, H27, MMM	2
14	PAOZZ	5310008071475	80205	MS21042L4	. NUT, SELF-LOCKING, EX..... UOC:A11, A24, A25, A26, A27, B17, B18, B24, B25, C17, H11, H17, H18, H24, H25, H26, H27, MMM	10
15	PAOZZ	2590012600216	31272	45619-11	. LINK ASSEMBLY, PLATF..... UOC:A11, A24, A25, A26, A27, B17, B18, B24, B25, C17, H11, H17, H18, H24, H25, H26, H27, MMM	2
16	PAOZZ	4010012712598	31272	45623-10	. WIRE ROPE ASSEMBLY,..... UOC:A11, A24, A25, A26, A27, B17, B18, B24, B25, C17, H11, H17, H18, H24, H25, H26, H27, MMM	2
17	PAOZZ	5310008071476	80205	MS21042L5	. NUT, SELF-LOCKING, EX..... UOC:A11, A24, A25, A26, A27, B17, B18, B24, B25, C17, H11, H17, H18, H24, H25, H26, H27, MMM	6
18	PAOZZ	5310001670836	88044	AN960-516L	. WASHER, FLAT..... UOC:A11, A24, A25, A26, A27, B17, B18, B24, B25, C17, H11, H17, H18, H24, H25, H26, H27, MMM	6
19	PAOZZ	5315007652190	31272	BLC5LA13S	. PIN, QUICK RELEASE..... UOC:A11, A24, A25, A26, A27, B17, B18, B24, B25, C17, H11, H17, H18, H24, H25, H26, H27, MMM	2
20	PFOZZ	2590012600217	31272	45616-11	. BRACKET ASSEMBLY, RE..... UOC:A11, A24, A25, A26, A27, B17, B18, B24, B25, C17, H11, H17, H18, H24, H25, H26, H27, MMM	1
21	PFOZZ	5340012600218	31272	45615-10	. BRACKET, MOUNTING..... UOC:A11, A24, A25, A26, A27, B17, B18, B24, B25, C17, H11, H17, H18, H24, H25, H26, H27, MMM	1
22	PFOZZ	2590012610523	31272	45608-10	. RAIL, PLATFORM, GUNNE..... UOC:A11, A24, A25, A26, A27, B17, B18, B24, B25, C17, H11, H17, H18, H24, H25, H26, H27, MMM	2
23	PAOZZ	5305000432682	96906	MS24694-S98	. SCREW, MACHINE..... UOC:A11, A24, A25, A26, A27, B17, B18, B24, B25, C17, H11, H17, H18, H24, H25, H26, H27, MMM	4
24	PAOZZ	5307012866007	31272	45610-10	. STUD, PLAIN..... UOC:A11, A24, A25, A26, A27, B17, B18, B24, B25, C17, H11, H17, H18, H24, H25, H26, H27, MMM	2
25	PFOZZ	5340012714281	31272	45618-10	. BRACKET, ANGLE..... UOC:A11, A24, A25, A26, A27, B17, B18, B24, B25, C17, H11, H17, H18, H24, H25, H26, H27, MMM	1
26	PAOZZ	5310008071477	80205	MS21042L6	. NUT, SELF-LOCKING, EX.....	2

SECTION II			TM9-2320-280-24P			
(1)	(2)	(3)	(4)	(5)	(6)	(7)
ITEM	SMR			PART		
NO	CODE	NSN	CAGEC	NUMBER	DESCRIPTION AND USABLE ON CODES(UC)	QTY
					UOC:A11,A24,A25,A26,A27,B17,B18,B24, B25,C17,H11,H17,H18,H24,H25,H26,H27, MMM	
27	PAOZZ	5310001670834	99167	25932	.WASHER,FLAT.....	8
					UOC:A11,A24,A25,A26,A27,B17,B18,B24, B25,C17,H11,H17,H18,H24,H25,H26,H27, MMM	
28	PAOZZ	5310002081918	88044	AN365-1024A	.NUT,SELF-LOCKING,HE #10-24.....	8
					UOC:A11,A24,A25,A26,A27,B17,B18,B24, B25,C17,H11,H17,H18,H24,H25,H26,H27, MMM	
29	PAOZZ	5305010062053	96906	MS51849-75	.SCREW,MACHINE #10-24 X 5/8.....	8
					UOC:A11,A24,A25,A26,A27,B17,B18,B24, B25,C17,H11,H17,H18,H24,H25,H26,H27, MMM	
30	PAOZZ	5340012714282	31272	43977-12	.LOOP,STRAP FASTENER.....	4
					UOC:A11,A24,A25,A26,A27,B17,B18,B24, B25,C17,H11,H17,H18,H24,H25,H26,H27, MMM	
31	PAOZZ	5340012758567	31272	45410-19	.STRAP,WEBBING.....	2
					UOC:A11,A24,A25,A26,A27,B17,B18,B24, B25,C17,H11,H17,H18,H24,H25,H26,H27, MMM	
32	PAOZZ	5306012636142	34623	5593345	BOLT,MACHINE 5/16-18 X 2.00.....	3
					UOC:A11,A24,A25,A26,A27,B17,B18,B24, B25,C17,H11,H17,H18,H24,H25,H26,H27, MMM	
33	PAOZZ	5310012520512	34623	5592832	WASHER,FLAT 5/16.....	10
					UOC:A11,A24,A25,A26,A27,B17,B18,B24, B25,C17,H11,H17,H18,H24,H25,H26,H27, MMM	
34	PAOZZ	5310012170715	34623	5591514	NUT,SELF-LOCKING,EX 5/16-18.....	5
					UOC:A11,A24,A25,A26,A27,B17,B18,B24, B25,C17,H11,H17,H18,H24,H25,H26,H27, MMM	
35	PAOZZ	5305002264831	80204	B1821BH031C150N	SCREW,CAP,HEXAGON H 5/16-18 X 1.50.	1
					UOC:A11,A24,A25,A26,A27,B17,B18,B24, B25,C17,H11,H17,H18,H24,H25,H26,H27, MMM	
36	PAOZZ	5340012581547	34623	5593807	BRACKET,DOUBLE ANGL.....	2
					UOC:A11,A24,A25,A26,A27,B17,B18,B24, B25,C17,H11,H17,H18,H24,H25,H26,H27, MMM	
37	PAOZZ	5306012542360	34623	5592879	BOLT,MACHINE 5/16-18 X 1.00.....	1
					UOC:A11,A24,A25,A26,A27,B17,B18,B24, B25,C17,H11,H17,H18,H24,H25,H26,H27, MMM	

END OF FIGURE

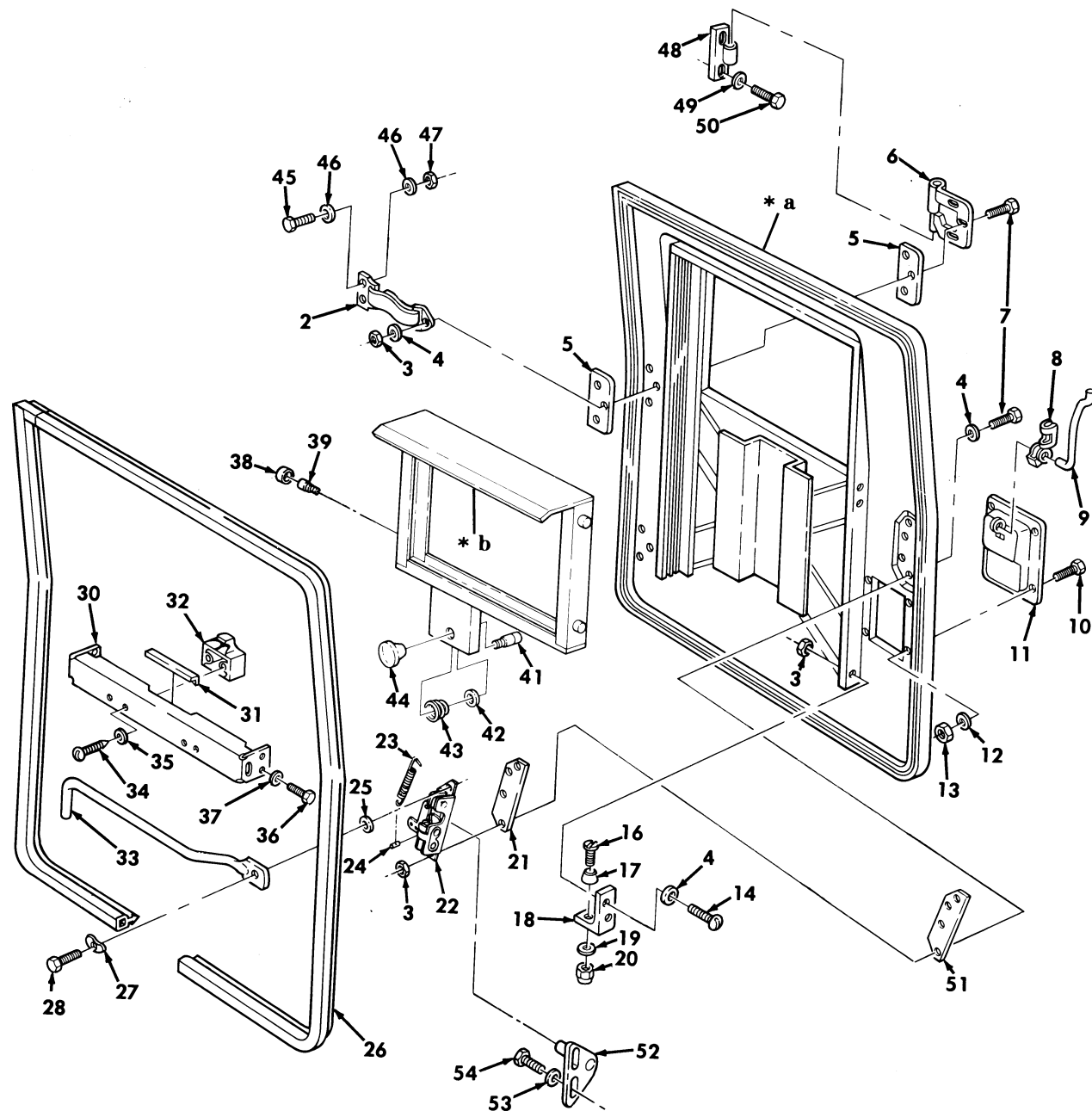
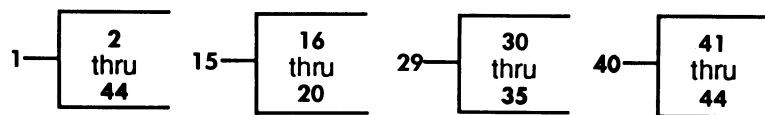

\* a PART OF ITEM 1  
 \* b PART OF ITEM 40

Figure 280. Crew Door Assembly, Front, Ballistic.

SECTION II			TM9-2320-280-24P			
(1)	(2)	(3)	(4)	(5)	(6)	(7)
ITEM	SMR			PART		
NO	CODE	NSN	CAGEC	NUMBER	DESCRIPTION AND USABLE ON CODES(UOC)	QTY
GROUP 1812 SPECIAL PURPOSE BODIES						
FIG. 280 CREW DOOR ASSEMBLY, FRONT, BALLISTIC						
1	PAOFF	2510012573903	19207	12339480-1	DOOR,VEHICULAR BASIC ARMOR,L.H..... UOC:A11,A15,B15,B16,B17,B18,C17,H11, H15,H16,H17,H18,MMM	1
1	PAOFF	2510012541500	19207	12339480-2	DOOR,VEHICULAR BASIC ARMOR,R.H..... UOC:A11,A15,B15,B16,B17,B18,C17,H11, H15,H16,H17,H18,MMM	1
1	PFOFF	2510012541482	19207	12339469-1	DOOR,VEHICULAR SUPPLEMENTAL ARMOR, L.H.....	1
					UOC:A24,A25,A26,A27,B24,B25,H24,H25, H26,H27	
1	PFOFF	2510012533907	19207	12339469-2	DOOR,VEHICULAR SUPPLEMENTAL ARMOR, R.H.....	1
					UOC:A24,A25,A26,A27,B24,B25,H24,H25, H26,H27	
2	PAOZZ	5340012538971	31272	45262-13	.STRAP,WEBBING UPPER HINGE L.H..... UOC:A11,A15,A24,A25,A26,A27,B15,B16, B17,B18,B24,B25,C17,H11,H15,H16,H17, H18,H24,H25,H26,H27,MMM	1
2	PAOZZ	5340012559918	31272	45262-11	.STRAP,WEBBING UPPER HINGE R.H..... UOC:A11,A15,A24,A25,A26,A27,B15,B16, B17,B18,B24,B25,C17,H11,H15,H16,H17, H18,H24,H25,H26,H27,MMM	1
3	PAOZZ	5310012544284	19207	12339730	.NUT,SELF-LOCKING,HE 1/4-20..... UOC:A11,A15,A24,A25,A26,A27,B15,B16, B17,B18,B24,B25,C17,H11,H15,H16,H17, H18,H24,H25,H26,H27,MMM	14
4	PAOZZ	5310012538949	34623	5592926	.WASHER,FLAT 1/4..... UOC:A11,A15,A24,A25,A26,A27,B15,B16, B17,B18,B24,B25,C17,H11,H15,H16,H17, H18,H24,H25,H26,H27,MMM	20
5	PFOZZ	5365012014749	34623	5584436	.SPACER,PLATE INNER AND OUTER, HINGE,SUPPLEMENTAL ARMOR.....	1
					UOC:A24,A25,A26,A27,B24,B25,H24,H25, H26,H27	
5	PFOZZ	5365012014749	34623	5584436	.SPACER,PLATE INNER AND OUTER, HINGE,BASIC ARMOR.....	4
					UOC:A11,A15,B15,B16,B17,B18,C17,H11, H15,H16,H17,H18,MMM	
6	PFOZZ	5340012042458	34623	5584325	.LEAF,BUTT HINGE LOWER,L.H..... UOC:A11,A15,A24,A25,A26,A27,B15,B16, B17,B18,B24,B25,C17,H11,H15,H16,H17, H18,H24,H25,H26,H27,MMM	1
6	PFOZZ	5340011993498	34623	12339448-1	.HINGE,ACCESS DOOR UPPER,L.H..... UOC:A11,A15,A24,A25,A26,A27,B15,B16, B17,B18,B24,B25,C17,H11,H15,H16,H17, H18,H24,H25,H26,H27,MMM	1
6	PFOZZ	5340012019076	34623	12339448-4	.LEAF,BUTT HINGE LOWER,R.H..... UOC:A11,A15,A24,A25,A26,A27,B15,B16,	1

SECTION II			TM9-2320-280-24P			
(1)	(2)	(3)	(4)	(5)	(6)	(7)
ITEM NO	SMR CODE	NSN	CAGEC	PART NUMBER	DESCRIPTION AND USABLE ON CODES(UOC)	QTY
6	PFOZZ	5340011978675	34623	5584867	B17,B18,B24,B25,C17,H11,H15,H16,H17, H18,H24,H25,H26,H27,MMM .LEAF,BUTT HINGE UPPER,R.H.....	1
7	PAOZZ	5305010524438	96906	MS51957-134	UOC:A11,A15,A24,A25,A26,A27,B15,B16, B17,B18,B24,B25,C17,H11,H15,H16,H17, H18,H24,H25,H26,H27,MMM .SCREW,MACHINE 1/4-20 X 1.38.....	10
8	PAOZZ	5340011982240	83058	HS99417	UOC:A11,A15,A24,A25,A26,A27,B15,B16, B17,B18,B24,B25,C17,H11,H15,H16,H17, H18,H24,H25,H26,H27,MMM .CLIP-CLEVIS,ROD RET.....	1
8	PAOZZ	5340011982241	83058	HS99338	UOC:A11,A15,A24,A25,A26,A27,B15,B16, B17,B18,B24,B25,C17,H11,H15,H16,H17, H18,H24,H25,H26,H27,MMM .CLIP-CLEVIS,ROD RET R.H.....	1
9	PFOZZ	2510011991498	19207	12339378-1	UOC:A11,A15,A24,A25,A26,A27,B15,B16, B17,B18,B24,B25,C17,H11,H15,H16,H17, H18,H24,H25,H26,H27,MMM .HOOK,LATCH VEHICULA L.H.....	1
9	PFOZZ	5340011974901	19207	12339378-2	UOC:A11,A15,A24,A25,A26,A27,B15,B16, B17,B18,B24,B25,C17,H11,H15,H16,H17, H18,H24,H25,H26,H27,MMM .LEVER,LOCK-RELEASE R.H.....	1
10	PAOZZ	5305009846196	96906	MS35206-248	UOC:A11,A15,A24,A25,A26,A27,B15,B16, B17,B18,B24,B25,C17,H11,H15,H16,H17, H18,H24,H25,H26,H27,MMM .SCREW,MACHINE #8-32 X 7/8.....	4
11	PAOZZ	5340012094870	19220	249	UOC:A11,A15,A24,A25,A26,A27,B15,B16, B17,B18,B24,B25,C17,H11,H15,H16,H17, H18,H24,H25,H26,H27,MMM .HANDLE,RECESS FRONT.....	1
12	PAOZZ	5310012538952	34623	5593241	UOC:A11,A15,A24,A25,A26,A27,B15,B16, B17,B18,B24,B25,C17,H11,H15,H16,H17, H18,H24,H25,H26,H27,MMM .WASHER,FLAT #8.....	4
13	PAOZZ	5310011983487	19207	12339728-3	UOC:A11,A15,A24,A25,A26,A27,B15,B16, B17,B18,B24,B25,C17,H11,H15,H16,H17, H18,H24,H25,H26,H27,MMM .NUT,SELF-LOCKING,HE #8-32.....	4
14	PAOZZ	5305009881725	96906	MS35206-281	UOC:A11,A15,A24,A25,A26,A27,B15,B16, B17,B18,B24,B25,C17,H11,H15,H16,H17, H18,H24,H25,H26,H27,MMM .SCREW,MACHINE 1/4-20 X 3/4.....	4
15	PAOOO	2510011965316	19207	12339416-1	UOC:A11,A15,A24,A25,A26,A27,B15,B16, B17,B18,B24,B25,C17,H11,H15,H16,H17, H18,H24,H25,H26,H27,MMM .STOP ASSEMBLY,WINDO L.H.....	2
15	PAOOO	5342011958039	19207	12339416-2	UOC:A11,A15,A24,A25,A26,A27,B15,B16, B17,B18,B24,B25,C17,H11,H15,H16,H17, H18,H24,H25,H26,H27,MMM .STOP ASSEMBLY,WINDO R.H.....	2

SECTION II			TM9-2320-280-24P			
(1)	(2)	(3)	(4)	(5)	(6)	(7)
ITEM NO	SMR CODE	NSN	CAGEC	PART NUMBER	DESCRIPTION AND USABLE ON CODES(UC)	QTY
16	PAOZZ	5305000509233	96906	MS51957-67	H18,H24,H25,H26,H27,MMM ..SCREW,MACHINE #10-24 X 1.00.....	1
					UOC:A11,A15,A24,A25,A26,A27,B15,B16, B17,B18,B24,B25,C17,H11,H15,H16,H17, H18,H24,H25,H26,H27,MMM	
17	PAOZZ	5340012038675	76385	ZB-1079M.I.	..BUMPER,NONMETALLIC.....	1
					UOC:A11,A15,A24,A25,A26,A27,B15,B16, B17,B18,B24,B25,C17,H11,H15,H16,H17, H18,H24,H25,H26,H27,MMM	
18	PFOZZ	5340012030324	34623	5584421	..BRACKET,ANGLE L.H.....	1
					UOC:A11,A15,A24,A25,A26,A27,B15,B16, B17,B18,B24,B25,C17,H11,H15,H16,H17, H18,H24,H25,H26,H27,MMM	
18	PFOZZ	5340011959107	19207	12339404-2	..BRACKET,ANGLE R.H.....	1
					UOC:A11,A15,A24,A25,A26,A27,B15,B16, B17,B18,B24,B25,C17,H11,H15,H16,H17, H18,H24,H25,H26,H27,MMM	
19	PAOZZ	5310012538953	34623	5593242	..WASHER,FLAT #10.....	1
					UOC:A11,A15,A24,A25,A26,A27,B15,B16, B17,B18,B24,B25,C17,H11,H15,H16,H17, H18,H24,H25,H26,H27,MMM	
20	PAOZZ	5310012033217	34623	5584710	..NUT,SELF-LOCKING,HE #10-24.....	1
					UOC:A11,A15,A24,A25,A26,A27,B15,B16, B17,B18,B24,B25,C17,H11,H15,H16,H17, H18,H24,H25,H26,H27,MMM	
21	PFOZZ	5365011979383	34623	5584299	..SPACER,PLATE.....	1
					UOC:A11,A15,A24,A25,A26,A27,B15,B16, B17,B18,B24,B25,C17,H11,H15,H16,H17, H18,H24,H25,H26,H27,MMM	
22	PAOZZ	2540011974900	19207	12340039-1	..LATCH,DOOR,VEHICULA L.H.....	1
					UOC:A11,A15,A24,A25,A26,A27,B15,B16, B17,B18,B24,B25,C17,H11,H15,H16,H17, H18,H24,H25,H26,H27,MMM	
22	PFOZZ	2540011965317	19220	9-300-U-R	..LOCK,DOOR,VEHICULAR DOOR ASSEMBLY R.H.....	1
					UOC:A11,A15,A24,A25,A26,A27,B15,B16, B17,B18,B24,B25,C17,H11,H15,H16,H17, H18,H24,H25,H26,H27,MMM	
23	PAOZZ	5360012829316	19220	2-300-P5	..SPRING,HELICAL,EXTE.....	1
					UOC:A11,A15,A24,A25,A26,A27,B15,B16, B17,B18,B24,B25,C17,H11,H15,H16,H17, H18,H24,H25,H26,H27,MMM	
24	PAOZZ	5315013003012	19220	565698-4	..PIN,STRAIGHT,HEADED.....	1
					UOC:A11,A15,A24,A25,A26,A27,B15,B16, B17,B18,B24,B25,C17,H11,H15,H16,H17, H18,H24,H25,H26,H27,MMM	
25	PAOZZ	5310000806004	96906	MS27183-14	..WASHER,FLAT 3/8.....	1
					UOC:A11,A15,A24,A25,A26,A27,B15,B16, B17,B18,B24,B25,C17,H11,H15,H16,H17, H18,H24,H25,H26,H27,MMM	
26	PAOZZ	5330011988789	19207	12339463-1	..SEAL,NONMETALLIC SP L.H.....	1
					UOC:A11,A15,A24,A25,A26,A27,B15,B16, B17,B18,B24,B25,C17,H11,H15,H16,H17,	



SECTION II			TM9-2320-280-24P			
(1)	(2)	(3)	(4)	(5)	(6)	(7)
ITEM	SMR			PART		
NO	CODE	NSN	CAGEC	NUMBER	DESCRIPTION AND USABLE ON CODES(UOC)	QTY
26	PAOZZ	5330011967968	19207	12339463-2	H18,H24,H25,H26,H27,MMM .SEAL,NONMETALLIC SP R.H.....	1
					UOC:A11,A15,A24,A25,A26,A27,B15,B16, B17,B18,B24,B25,C17,H11,H15,H16,H17, H18,H24,H25,H26,H27,MMM	
27	PAOZZ	5310011983428	34623	5584713	.WASHER,SPRING TENSI 3/8.....	1
					UOC:A11,A15,A24,A25,A26,A27,B15,B16, B17,B18,B24,B25,C17,H11,H15,H16,H17, H18,H24,H25,H26,H27,MMM	
28	PAOZZ	5306012042139	34623	5589067	.BOLT,SELF-LOCKING 1/4-20 X 1/2....	1
					UOC:A11,A15,A24,A25,A26,A27,B15,B16, B17,B18,B24,B25,C17,H11,H15,H16,H17, H18,H24,H25,H26,H27,MMM	
29	PAOOO	2540011995812	34623	12339454-1	.LATCH,DOOR,VEHICULA L.H.....	1
					UOC:A11,A15,A24,A25,A26,A27,B15,B16, B17,B18,B24,B25,C17,H11,H15,H16,H17, H18,H24,H25,H26,H27,MMM	
29	PAOOO	5340011987580	34623	5584259	.BRACKET,MOUNTING R.H.....	1
					UOC:A11,A15,A24,A25,A26,A27,B15,B16, B17,B18,B24,B25,C17,H11,H15,H16,H17, H18,H24,H25,H26,H27,MMM	
30	XAOZZ		34623	5588063	..BRACKET ASSEMBLY.....	1
					UOC:A11,A15,A24,A25,A26,A27,B15,B16, B17,B18,B24,B25,C17,H11,H15,H16,H17, H18,H24,H25,H26,H27,MMM	
31	MOOZZ		34623	5584707	..PROTECTOR,EDGE MAKE FROM PAD,P/N 12339902-1 8.90 INCHES LONG.....	1
					UOC:A11,A15,A24,A25,A26,A27,B15,B16, B17,B18,B24,B25,C17,H11,H15,H16,H17, H18,H24,H25,H26,H27,MMM	
32	PFOZZ	2510011991499	19207	12339450	..GUIDE,DOOR LATCH VE.....	1
					UOC:A11,A15,A24,A25,A26,A27,B15,B16, B17,B18,B24,B25,C17,H11,H15,H16,H17, H18,H24,H25,H26,H27,MMM	
33	PFOZZ	3040012001015	19207	12339452-1	..LEVER,REMOTE CONTRO L.H.....	1
					UOC:A11,A15,A24,A25,A26,A27,B15,B16, B17,B18,B24,B25,C17,H11,H15,H16,H17, H18,H24,H25,H26,H27,MMM	
33	PFOZZ	2510012113229	34623	5584264	..ARM,DOOR LATCH,VEHI R.H.....	1
					UOC:A11,A15,A24,A25,A26,A27,B15,B16, B17,B18,B24,B25,C17,H11,H15,H16,H17, H18,H24,H25,H26,H27,MMM	
34	PAOZZ	5305004324205	96906	MS51861-49	..SCREW,TAPPING #10-16 X 1.00.....	2
					UOC:A11,A15,A24,A25,A26,A27,B15,B16, B17,B18,B24,B25,C17,H11,H15,H16,H17, H18,H24,H25,H26,H27,MMM	
35	PAOZZ	5310012538953	34623	5593242	..WASHER,FLAT #10.....	2
					UOC:A11,A15,A24,A25,A26,A27,B15,B16, B17,B18,B24,B25,C17,H11,H15,H16,H17, H18,H24,H25,H26,H27,MMM	
36	PAOZZ	5305009846193	96906	MS35206-245	.SCREW,MACHINE #8-32 X 1/2.....	4
					UOC:A11,A15,A24,A25,A26,A27,B15,B16, B17,B18,B24,B25,C17,H11,H15,H16,H17,	

SECTION II			TM9-2320-280-24P			
(1)	(2)	(3)	(4)	(5)	(6)	(7)
ITEM NO	SMR CODE	NSN	CAGEC	PART NUMBER	DESCRIPTION AND USABLE ON CODES(UC)	QTY
37	PAOZZ	5310012538952	34623	5593241	H18, H24, H25, H26, H27, MMM .WASHER, FLAT #8..... V	
					UOC:A11, A15, A24, A25, A26, A27, B15, B16, B17, B18, B24, B25, C17, H11, H15, H16, H17, H18, H24, H25, H26, H27, MMM	
38	PAOZZ	5355012526504	19207	12339380	.KNOB..... 4	
					UOC:A11, A15, A24, A25, A26, A27, B15, B16, B17, B18, B24, B25, C17, H11, H15, H16, H17, H18, H24, H25, H26, H27, MMM	
39	PAOZZ	5315012042328	34623	5584278	.PIN, SHOULDER, HEADLE..... 4	
					UOC:A11, A15, A24, A25, A26, A27, B15, B16, B17, B18, B24, B25, C17, H11, H15, H16, H17, H18, H24, H25, H26, H27, MMM	
40	PAOOO	2510011899748	19207	12339374-2	.WINDOW ASSEMBLY, VEH BALLISTIC FRONT DOOR, BASIC, L.H..... 1	
					UOC:A11, A15, B15, B16, B17, B18, C17, H11, H15, H16, H17, H18, MMM	
40	PAOOO	2510011887381	19207	12339374-1	.WINDOW ASSEMBLY, VEH BALLISTIC FRONT DOOR, BASIC, R.H..... 1	
					UOC:A11, A15, B15, B16, B17, B18, C17, H11, H15, H16, H17, H18, MMM	
40	PAOOO	2510012093450	19207	12339375-1	.WINDOW, VEHICULAR L.H., SUPPLEMENTAL ARMOR..... 1	
					UOC:A24, A25, A26, A27, B24, B25, H24, H25, H26, H27	
40	PAOOO	2510011965506	19207	12339375-2	.WINDOW, VEHICULAR R.H., SUPPLEMENTAL ARMOR..... 1	
					UOC:A24, A25, A26, A27, B24, B25, H24, H25, H26, H27	
41	PAOZZ	5315012038543	19207	12339726	..PIN, SHOULDER, HEADLE..... 1	
					UOC:A11, A15, A24, A25, A26, A27, B15, B16, B17, B18, B24, B25, C17, H11, H15, H16, H17, H18, H24, H25, H26, H27, MMM	
42	PAOZZ	5325004425845	96906	MS16633-1050	..RING, RETAINING..... 1	
					UOC:A11, A15, A24, A25, A26, A27, B15, B16, B17, B18, B24, B25, C17, H11, H15, H16, H17, H18, H24, H25, H26, H27, MMM	
43	PFOZZ	5360011983525	19207	12339369	..SPRING, HELICAL, COMP..... 1	
					UOC:A11, A15, A24, A25, A26, A27, B15, B16, B17, B18, B24, B25, C17, H11, H15, H16, H17, H18, H24, H25, H26, H27, MMM	
44	PAOZZ	5355012988571	80813	1-236-005	..KNOB..... 1	
					UOC:A11, A15, A24, A25, A26, A27, B15, B16, B17, B18, B24, B25, C17, H11, H15, H16, H17, H18, H24, H25, H26, H27, MMM	
45	PAOZZ	5306002259089	96906	MS90726-34	BOLT, MACHINE 5/16-24 X 1.00..... 4	
					UOC:A11, A15, A24, A25, A26, A27, B15, B16, B17, B18, B24, B25, C17, H11, H15, H16, H17, H18, H24, H25, H26, H27, MMM	
46	PAFZZ	5310000814219	96906	MS27183-12	WASHER, FLAT 5/16..... 8	
					UOC:A11, A15, A24, A25, A26, A27, B15, B16, B17, B18, B24, B25, C17, H11, H15, H16, H17, H18, H24, H25, H26, H27, MMM	

SECTION II			TM9-2320-280-24P			
(1)	(2)	(3)	(4)	(5)	(6)	(7)
ITEM	SMR			PART		
NO	CODE	NSN	CAGEC	NUMBER	DESCRIPTION AND USABLE ON CODES(UC)	QTY
47	PAFZZ	5310002416658	96906	MS51943-34	NUT, SELF-LOCKING, HE 1/4-20..... UOC:A11, A15, A24, A25, A26, A27, B15, B16, B17, B18, B24, B25, C17, H11, H15, H16, H17, H18, H24, H25, H26, H27, MMM	4
48	PFOZZ	5342012032822	19207	12338650	MOUNT, RESILIENT..... UOC:A11, A15, A24, A25, A26, A27, B15, B16, B17, B18, B24, B25, C17, H11, H15, H16, H17, H18, H24, H25, H26, H27, MMM	4
49	PAOZZ	5310008094058	96906	MS27183-10	WASHER, FLAT 1/4..... UOC:A11, A15, A24, A25, A26, A27, B15, B16, B17, B18, B24, B25, C17, H11, H15, H16, H17, H18, H24, H25, H26, H27, MMM	8
50	PAOZZ	5306013235535	19207	12340352-1	BOLT, MACHINE 1/4-20 X 3/4..... UOC:A11, A15, A24, A25, A26, A27, B15, B16, B17, B18, B24, B25, C17, H11, H15, H16, H17, H18, H24, H25, H26, H27, MMM	8
51	PAOZZ	5365012538980	19207	12339379	SPACER, PLATE 0.063..... UOC:A11, A15, A24, A25, A26, A27, B15, B16, B17, B18, B24, B25, C17, H11, H15, H16, H17, H18, H24, H25, H26, H27, MMM	2
52	PFOZZ	5340012111645	34623	5584294	LATCH, RIM..... UOC:A11, A15, A24, A25, A26, A27, B15, B16, B17, B18, B24, B25, C17, H11, H15, H16, H17, H18, H24, H25, H26, H27, MMM	2
53	PAOZZ	5310012538949	34623	5592926	WASHER, FLAT 1/4..... UOC:A11, A15, A24, A25, A26, A27, B15, B16, B17, B18, B24, B25, C17, H11, H15, H16, H17, H18, H24, H25, H26, H27, MMM	4
54	PAOZZ	5305000712505	80204	B1821BH025C088N	SCREW, CAP, HEXAGON H 1/4-20 X 7/8... UOC:A11, A15, A24, A25, A26, A27, B15, B16, B17, B18, B24, B25, C17, H11, H15, H16, H17, H18, H24, H25, H26, H27, MMM	4

END OF FIGURE

Section II.

TM 9-2320-280-24P-1

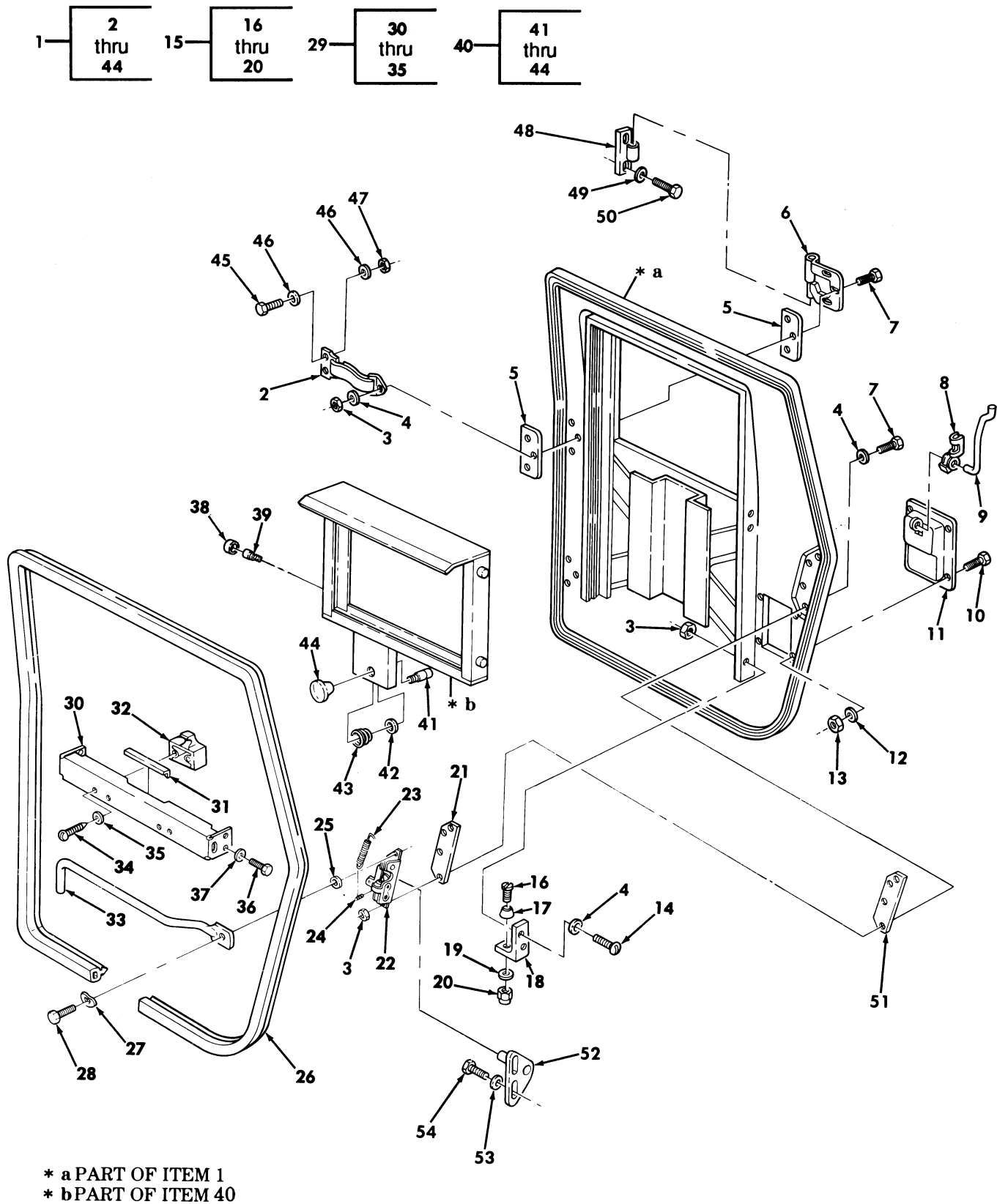

Figure 281. Crew Door Assembly, Rear, Ballistic.

SECTION II			TM9-2320-280-24P			
(1)	(2)	(3)	(4)	(5)	(6)	(7)
ITEM NO	SMR CODE	NSN	CAGEC	PART NUMBER	DESCRIPTION AND USABLE ON CODES(UOC)	QTY
GROUP 1812 SPECIAL PURPOSE BODIES						
FIG. 281 CREW DOOR ASSEMBLY, REAR, BALLISTIC						
1	PAOFF	2510012541501	19207	12339473-1	DOOR,VEHICULAR BASIC ARMOR,L.H..... UOC:A11,B17,B18,C17,H11,H17,H18,MMM	1
1	PAOFF	2510012573904	19207	12339473-2	DOOR,VEHICULAR BASIC ARMOR,R.H..... UOC:A11,B17,B18,C17,H11,H17,H18,MMM	1
1	PAOFF	2510012573876	19207	12339477-1	DOOR,VEHICULAR SUPPLEMENTAL ARMOR, L.H..... UOC:A24,A25,A26,A27,B24,H24,H25,H26, H27	1
1	PFOFF	2510012541483	34623	12339477-2	DOOR,VEHICULAR SUPPLEMENTAL ARMOR, R.H..... UOC:A24,A25,A26,A27,B24,H24,H25,H26, H27	1
2	PAOZZ	5340012538971	31272	45262-13	.STRAP,WEBBING UPPER HINGE,L.H..... UOC:A11,A24,A25,A26,A27,B17,B18,B24, B25,C17,H11,H17,H18,H24,H25,H26,H27, MMM	1
2	PAOZZ	5340012559918	31272	45262-11	.STRAP,WEBBING UPPER HINGE,R.H..... UOC:A11,A24,A25,A26,A27,B17,B18,B24, B25,C17,H11,H17,H18,H24,H25,H26,H27, MMM	1
3	PAOZZ	5310012544284	19207	12339730	.NUT,SELF-LOCKING,HE 1/4-20..... UOC:A11,A24,A25,A26,A27,B17,B18,B24, B25,C17,H11,H17,H18,H24,H25,H26,H27, MMM	14
4	PAOZZ	5310012538949	34623	5592926	.WASHER,FLAT 1/4..... UOC:A11,A24,A25,A26,A27,B17,B18,B24, B25,C17,H11,H17,H18,H24,H25,H26,H27, MMM	20
5	PFOZZ	5365012014749	34623	5584436	.SPACER,PLATE INNER AND OUTER HINGE,SUPPLEMENTAL ARMOR..... UOC:A24,A25,A26,A27,B24,H24,H25,H26, H27	2
5	PFOZZ	5365012014749	34623	5584436	.SPACER,PLATE INNER AND OUTER HINGE,BASIC ARMOR..... UOC:A11,B17,B18,C17,H11,H17,H18,MMM	4
6	PFOZZ	5340012042458	34623	5584325	.LEAF,BUTT HINGE LOWER,L.H..... UOC:A11,A24,A25,A26,A27,B17,B18,B24, B25,C17,H11,H17,H18,H24,H25,H26,H27, MMM	1
6	PFOZZ	5340011993498	19207	12339448-1	.HINGE,ACCESS DOOR UPPER,L.H..... UOC:A11,A24,A25,A26,A27,B17,B18,B24, B25,C17,H11,H17,H18,H24,H25,H26,H27, MMM	1
6	PFOZZ	5340011978675	34623	5584867	.LEAF,BUTT HINGE UPPER,R.H..... UOC:A11,A24,A25,A26,A27,B17,B18,B24, B25,C17,H11,H17,H18,H24,H25,H26,H27, MMM	1
6	PFOZZ	5340012019076	34623	12339448-4	.LEAF,BUTT HINGE LOWER,R.H.....	1

SECTION II			TM9-2320-280-24P			
(1)	(2)	(3)	(4)	(5)	(6)	(7)
ITEM NO	SMR CODE	NSN	CAGEC	PART NUMBER	DESCRIPTION AND USABLE ON CODES(UOC)	QTY
7	PAOZZ	5305004826825	96906	MS35206-345	UOC:A11,A24,A25,A26,A27,B17,B18,B24, B25,C17,H11,H17,H18,H24,H25,H26,H27, MMM .SCREW,MACHINE 1/4-20 X 1.38.....	10
8	PAOZZ	5340011982240	83058	HS99417	UOC:A11,A24,A25,A26,A27,B17,B18,B24, B25,C17,H11,H17,H18,H24,H25,H26,H27, MMM .CLIP-CLEVIS,ROD RET L.H.....	1
8	PAOZZ	5340011982241	83058	HS99338	UOC:A11,A24,A25,A26,A27,B17,B18,B24, B25,C17,H11,H17,H18,H24,H25,H26,H27, MMM .CLIP-CLEVIS,ROD RET R.H.....	1
9	PFOZZ	2540012012356	19207	12339377-1	UOC:A11,A24,A25,A26,A27,B17,B18,B24, B25,C17,H11,H17,H18,H24,H25,H26,H27, MMM .HOOK,REAR LATCH L.H.....	1
9	PFOZZ	2540012012357	19207	12339377-2	UOC:A11,A24,A25,A26,A27,B17,B18,B24, B25,C17,H11,H17,H18,H24,H25,H26,H27, MMM .HOOK,REAR LATCH R.H.....	1
10	PAOZZ	5305009846196	96906	MS35206-248	UOC:A11,A24,A25,A26,A27,B17,B18,B24, B25,C17,H11,H17,H18,H24,H25,H26,H27, MMM .SCREW,MACHINE #8-32 X 7/8.....	4
11	PAOZZ	5340012094870	19220	249	UOC:A11,A24,A25,A26,A27,B17,B18,B24, B25,C17,H11,H17,H18,H24,H25,H26,H27, MMM .HANDLE,RECESS.....	1
12	PAOZZ	5310012538952	34623	5593241	UOC:A11,A24,A25,A26,A27,B17,B18,B24, B25,C17,H11,H17,H18,H24,H25,H26,H27, MMM .WASHER,FLAT #8.....	4
13	PAOZZ	5310011983487	19207	12339728-3	UOC:A11,A24,A25,A26,A27,B17,B18,B24, B25,C17,H11,H17,H18,H24,H25,H26,H27, MMM .NUT,SELF-LOCKING,HE #8-32.....	4
14	PAOZZ	5305009881725	96906	MS35206-281	UOC:A11,A24,A25,A26,A27,B17,B18,B24, B25,C17,H11,H17,H18,H24,H25,H26,H27, MMM .SCREW,MACHINE 1/4-20 X 3/4.....	4
15	PAOOO	2510011965316	19207	12339416-1	UOC:A11,A24,A25,A26,A27,B17,B18,B24, B25,C17,H11,H17,H18,H24,H25,H26,H27, MMM .STOP ASSEMBLY,WINDO L.H.....	2
15	PAOOO	5342011958039	19207	12339416-2	UOC:A11,A24,A25,A26,A27,B17,B18,B24, B25,C17,H11,H17,H18,H24,H25,H26,H27, MMM .STOP ASSEMBLY,WINDO R.H.....	2
16	PAOZZ	5305009846214	96906	MS35206-267	UOC:A11,A24,A25,A26,A27,B17,B18,B24, MMM ..SCREW,MACHINE #10-24 X 1.00.....	1

SECTION II			TM9-2320-280-24P			
(1)	(2)	(3)	(4)	(5)	(6)	(7)
ITEM NO	SMR CODE	NSN	CAGEC	PART NUMBER	DESCRIPTION AND USABLE ON CODES(UOC)	QTY
17	PAOZZ	5340012038675	76385	ZB-1079M.I.	B25,C17,H11,H17,H18,H24,H25,H26,H27, MMM ..BUMPER, NONMETALLIC.....	1
					UOC:A11,A24,A25,A26,A27,B17,B18,B24, B25,C17,H11,H17,H18,H24,H25,H26,H27, MMM	
18	PFOZZ	5340012030324	34623	5584421	..BRACKET, ANGLE L.H.....	1
					UOC:A11,A24,A25,A26,A27,B17,B18,B24, B25,C17,H11,H17,H18,H24,H25,H26,H27, MMM	
18	PFOZZ	5340011959107	19207	12339404-2	..BRACKET, ANGLE R.H.....	1
					UOC:A11,A24,A25,A26,A27,B17,B18,B24, B25,C17,H11,H17,H18,H24,H25,H26,H27, MMM	
19	PAOZZ	5310012538953	34623	5593242	..WASHER, FLAT #10.....	1
					UOC:A11,A24,A25,A26,A27,B17,B18,B24, B25,C17,H11,H17,H18,H24,H25,H26,H27, MMM	
20	PAOZZ	5310012033217	34623	5584710	..NUT, SELF-LOCKING, HE #10-24.....	1
					UOC:A11,A24,A25,A26,A27,B17,B18,B24, B25,C17,H11,H17,H18,H24,H25,H26,H27, MMM	
21	PFOZZ	5365011979383	34623	5584299	..SPACER, PLATE.....	1
					UOC:A11,A24,A25,A26,A27,B17,B18,B24, B25,C17,H11,H17,H18,H24,H25,H26,H27, MMM	
22	PFOZZ	2540011974900	19220	9-300-U-L	..LATCH, DOOR, VEHICULA L.H.....	1
					UOC:A11,A24,A25,A26,A27,B17,B18,B24, B25,C17,H11,H17,H18,H24,H25,H26,H27, MMM	
22	PFOZZ	2540011965317	19220	9-300-U-R	..LOCK, DOOR, VEHICULAR R.H.....	1
					UOC:A11,A24,A25,A26,A27,B17,B18,B24, B25,C17,H11,H17,H18,H24,H25,H26,H27, MMM	
23	PAOZZ	5360012829316	19220	2-300-P5	..SPRING, HELICAL, EXTE.....	1
					UOC:A11,A24,A25,A26,A27,B17,B18,B24, B25,C17,H11,H17,H18,H24,H25,H26,H27, MMM	
24	PAOZZ	5315013003012	19220	565698-4	..PIN, STRAIGHT, HEADED.....	1
					UOC:A11,A24,A25,A26,A27,B17,B18,B24, B25,C17,H11,H17,H18,H24,H25,H26,H27, MMM	
25	PAOZZ	5310000806004	96906	MS27183-14	..WASHER, FLAT 3/8.....	1
					UOC:A11,A24,A25,A26,A27,B17,B18,B24, B25,C17,H11,H17,H18,H24,H25,H26,H27, MMM	
26	PAOZZ	5330011967969	19207	12339462	..SEAL, NONMETALLIC SP.....	1
					UOC:A11,A24,A25,A26,A27,B17,B18,B24, B25,C17,H11,H17,H18,H24,H25,H26,H27, MMM	
27	PAOZZ	5310011983428	34623	5584713	..WASHER, SPRING TENSI 3/8.....	1
					UOC:A11,A24,A25,A26,A27,B17,B18,B24, B25,C17,H11,H17,H18,H24,H25,H26,H27,	

SECTION II			TM9-2320-280-24P			
(1)	(2)	(3)	(4)	(5)	(6)	(7)
ITEM NO	SMR CODE	NSN	CAGEC	PART NUMBER	DESCRIPTION AND USABLE ON CODES(UOC)	QTY
28	PAOZZ	5365012014749	19207	12339727	MMM .SPACER,PLATE 3/8-20 X 1/2..... UOC:A11,A24,A25,A26,A27,B17,B18,B24, B25,C17,H11,H17,H18,H24,H25,H26,H27, MMM	1
29	PAOOO	5340011976714	34623	5584260	..BRACKET,LATCH ASSEM L.H..... UOC:A11,A24,A25,A26,A27,B17,B18,B24, B25,C17,H11,H17,H18,H24,H25,H26,H27, MMM	1
29	PAOOO	2540011987581	34623	5584261	..LATCH,DOOR,VEHICULA R.H..... UOC:A11,A24,A25,A26,A27,B17,B18,B24, B25,C17,H11,H17,H18,H24,H25,H26,H27, MMM	1
30	XAOZZ		34623	5588063	..BRACKET ASSEMBLY..... UOC:A11,A24,A25,A26,A27,B17,B18,B24, B25,C17,H11,H17,H18,H24,H25,H26,H27, MMM	1
31	MOOZZ		34623	5584707	..PROTECTOR,EDGE MAKE FROM PAD,P/N 12339902-1,8.90 INCHES LONG..... UOC:A11,A24,A25,A26,A27,B17,B18,B24, B25,C17,H11,H17,H18,H24,H25,H26,H27, MMM	1
32	PFOZZ	2510011991499	19207	12339450	..GUIDE,DOOR LATCH VE..... UOC:A11,A24,A25,A26,A27,B17,B18,B24, B25,C17,H11,H17,H18,H24,H25,H26,H27, MMM	1
33	PFOZZ	3040011954173	34623	12339451-1	..LEVER,REMOTE CONTRO L.H..... UOC:A11,A24,A25,A26,A27,B17,B18,B24, B25,C17,H11,H17,H18,H24,H25,H26,H27, MMM	1
33	PFOZZ	3040011961493	34623	12339451-2	..LEVER,REMOTE CONTRO R.H..... UOC:A11,A24,A25,A26,A27,B17,B18,B24, B25,C17,H11,H17,H18,H24,H25,H26,H27, MMM	1
34	PAOZZ	5305004324205	96906	MS51861-49	..SCREW,TAPPING #10-16 X 1.00..... UOC:A11,A24,A25,A26,A27,B17,B18,B24, B25,C17,H11,H17,H18,H24,H25,H26,H27, MMM	2
35	PAOZZ	5310012538953	34623	5593242	..WASHER,FLAT #10..... UOC:A11,A24,A25,A26,A27,B17,B18,B24, B25,C17,H11,H17,H18,H24,H25,H26,H27, MMM	2
36	PAOZZ	5305009846193	96906	MS35206-245	..SCREW,MACHINE #10-16 X 1/2..... UOC:A11,A24,A25,A26,A27,B17,B18,B24, B25,C17,H11,H17,H18,H24,H25,H26,H27, MMM	4
37	PAOZZ	5310012538952	34623	5593241	..WASHER,FLAT #8..... V UOC:A11,A24,A25,A26,A27,B17,B18,B24, B25,C17,H11,H17,H18,H24,H25,H26,H27, MMM	
38	PAOZZ	5355012526504	19207	12339380	..KNOB..... UOC:A11,A24,A25,A26,A27,B17,B18,B24, B25,C17,H11,H17,H18,H24,H25,H26,H27,	4



SECTION II			TM9-2320-280-24P			
(1)	(2)	(3)	(4)	(5)	(6)	(7)
ITEM NO	SMR CODE	NSN	CAGEC	PART NUMBER	DESCRIPTION AND USABLE ON CODES(UOC)	QTY
39	PAOZZ	5315012042328	34623	5584278	MMM .PIN, SHOULDER, HEADLE.....	4
					UOC:A11, A24, A25, A26, A27, B17, B18, B24, B25, C17, H11, H17, H18, H24, H25, H26, H27, MMM	
40	PAOOO	2510011899748	19207	12339374-2	.WINDOW ASSEMBLY,VEH BALLISTIC REAR DOOR,BASIC,L.H.....	1
					UOC:A11, B17, B18, C17, H11, H17, H18, MMM	
40	PAOOO	2510012093450	19207	12339375-1	.WINDOW,VEHICULAR BALLISTIC REAR DOOR,SUPPLEMENTAL,L.H.....	1
					UOC:A24, A25, A26, A27, B24, H24, H25, H26, H27	
40	PAOOO	2510011887381	19207	12339374-1	.WINDOW ASSEMBLY,VEH BALLISTIC REAR DOOR,BASIC,R.H.....	1
					UOC:A11, B17, B18, C17, H11, H17, H18, MMM	
40	PAOOO	2510011965506	19207	12339375-2	.WINDOW,VEHICULAR BALLISTIC,REAR DOOR,SUPPLEMENTAL,R.H.....	1
					UOC:A24, A25, A26, A27, B24, B25, H24, H25, H26, H27	
41	PAOZZ	5315012038543	19207	12339726	..PIN, SHOULDER, HEADLE.....	1
					UOC:A11, A24, A25, A26, A27, B17, B18, B24, B25, C17, H11, H17, H18, H24, H25, H26, H27, MMM	
42	PAOZZ	5325004425845	96906	MS16633-1050	..RING,RETAINING.....	1
					UOC:A11, A24, A25, A26, A27, B17, B18, B24, B25, C17, H11, H17, H18, H24, H25, H26, H27, MMM	
43	PAOZZ	5360011983525	19207	12339369	..SPRING,HELICAL,COMP.....	1
					UOC:A11, A24, A25, A26, A27, B17, B18, B24, B25, C17, H11, H17, H18, H24, H25, H26, H27, MMM	
44	PAOZZ	5355012988571	80813	1-236-005	..KNOB.....	1
					UOC:A11, A24, A25, A26, A27, B17, B18, B24, B25, C17, H11, H17, H18, H24, H25, H26, H27, MMM	
45	PAOZZ	5306002259089	96906	MS90726-34	BOLT,MACHINE 5/16-24 X 1.00.....	4
					UOC:A11, A24, A25, A26, A27, B17, B18, B24, B25, C17, H11, H17, H18, H24, H25, H26, H27, MMM	
46	PAOZZ	5310000814219	96906	MS27183-12	WASHER,FLAT 5/16.....	8
					UOC:A11, A24, A25, A26, A27, B17, B18, B24, B25, C17, H11, H17, H18, H24, H25, H26, H27, MMM	
47	PAOZZ	5310002416658	96906	MS51943-34	NUT,SELF-LOCKING,HE 5/16-24.....	4
					UOC:A11, A24, A25, A26, A27, B17, B18, B24, B25, C17, H11, H17, H18, H24, H25, H26, H27, MMM	
48	PFOZZ	5342012032822	19207	12338650	MOUNT,RESILIENT A-PILLAR,REAR DOOR.	4
					UOC:A11, A24, A25, A26, A27, B17, B18, B24, B25, C17, H11, H17, H18, H24, H25, H26, H27, MMM	
49	PAOZZ	5310008094058	96906	MS27183-10	WASHER,FLAT 1/4.....	8
					UOC:A11, A24, A25, A26, A27, B17, B18, B24,	

SECTION II			TM9-2320-280-24P			
(1)	(2)	(3)	(4)	(5)	(6)	(7)
ITEM	SMR			PART		
NO	CODE	NSN	CAGEC	NUMBER	DESCRIPTION AND USABLE ON CODES(UC)	QTY
50	PAOZZ	5306013235535	34623	5585259	B25,C17,H11,H17,H18,H24,H25,H26,H27, MMM BOLT,MACHINE 1/4-20 X 3/4.....	8
					UOC:A11,A24,A25,A26,A27,B17,B18,B24, B25,C17,H11,H17,H18,H24,H25,H26,H27, MMM	
51	PAOZZ	5365012538980	19207	12339379	SPACER,PLATE 0.063.....	2
					UOC:A11,A24,A25,A26,A27,B17,B18,B24, B25,C17,H11,H17,H18,H24,H25,H26,H27, MMM	
52	PAOZZ	5340014211782	19207	12339386	STRIKE,CATCH.....	2
					UOC:A11,A24,A25,A26,A27,B17,B18,B24, B25,C17,H11,H17,H18,H24,H25,H26,H27, MMM	
53	PAOZZ	5310012538949	34623	5592926	WASHER,FLAT 1/4.....	4
					UOC:A11,A24,A25,A26,A27,B17,B18,B24, B25,C17,H11,H17,H18,H24,H25,H26,H27, MMM	
54	PAOZZ	5305000712505	80204	B1821BH025C088N	SCREW,CAP,HEXAGON H 1/4-20 X 7/8...	4
					UOC:A11,A24,A25,A26,A27,B17,B18,B24, B25,C17,H11,H17,H18,H24,H25,H26,H27, MMM	

END OF FIGURE

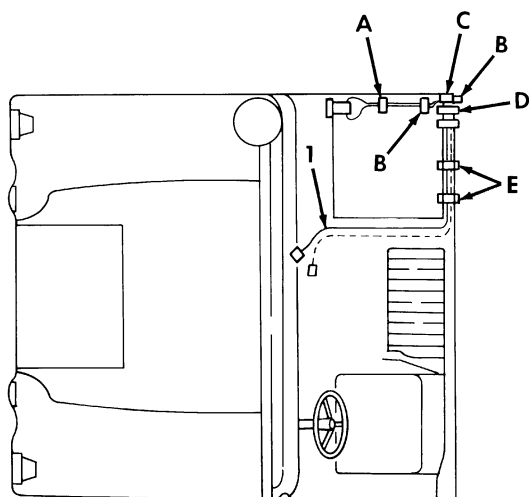

**CABLE ASSY-12340655**  
**USBL EFF 1 THRU 99,999**

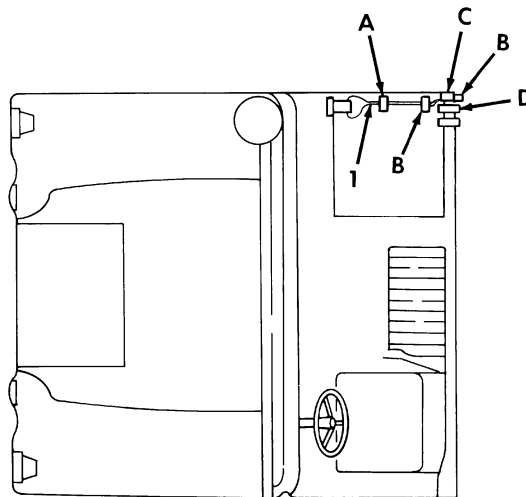

**CABLE ASSY-13495871 (M1121)**

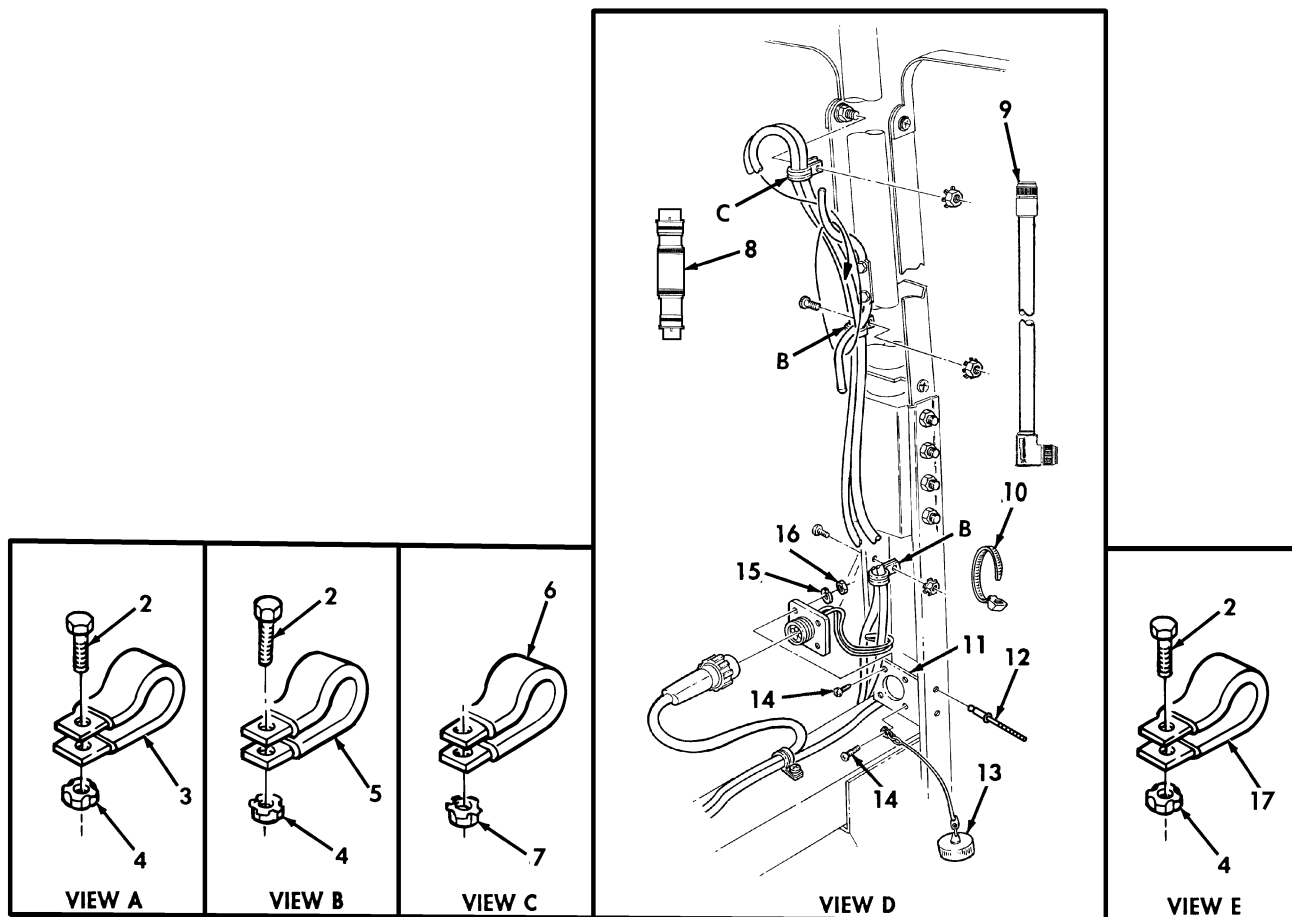

*Figure 282. TOW Electrical Cables and Mounting Hardware (Sheet 1 of 2).*

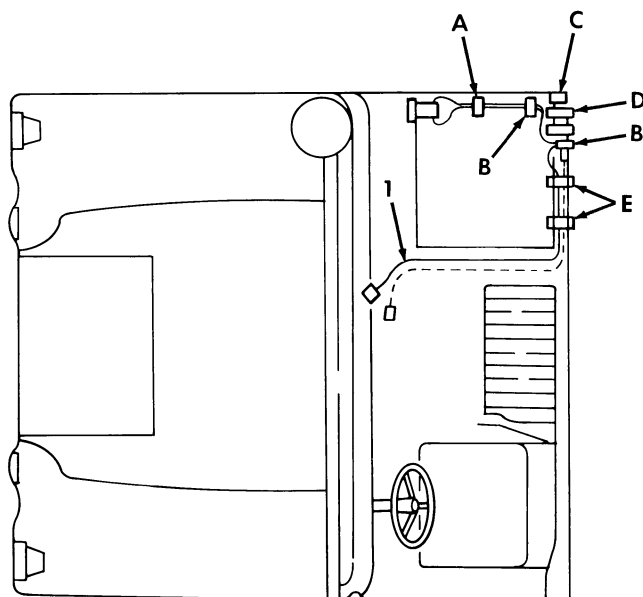

*USBL EFF 100,000 AND ABOVE*

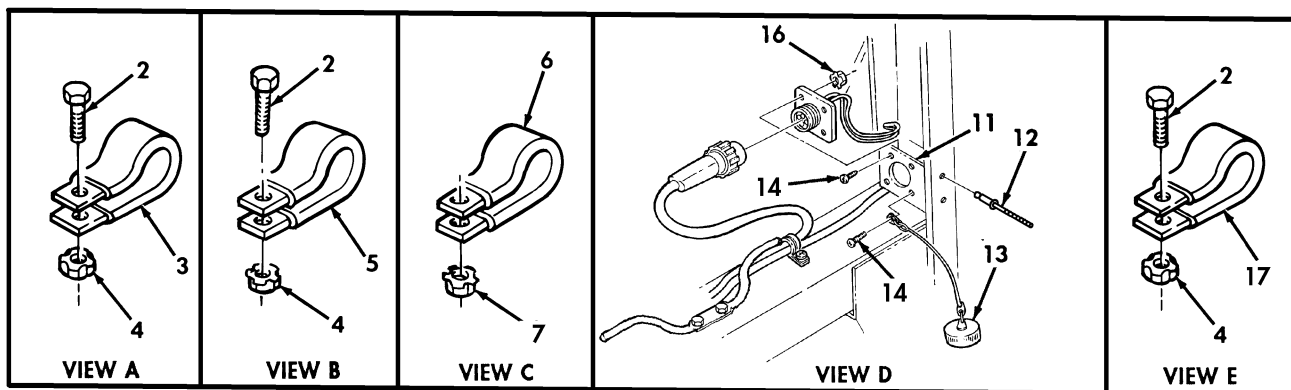

*Figure 282. TOW Electrical Cables and Mounting Hardware (Sheet 2 of 2).*

SECTION II			TM9-2320-280-24P			
(1)	(2)	(3)	(4)	(5)	(6)	(7)
ITEM	SMR			PART		
NO	CODE	NSN	CAGEC	NUMBER	DESCRIPTION AND USABLE ON CODES(UOC)	QTY
GROUP 1812 SPECIAL PURPOSE BODIES						
FIG. 282 TOW ELECTRICAL CABLES AND MOUNTING HARDWARE						
1	PFOZZ	5995011951918	19207	12340655	WIRING HARNESS,BRAN USBL EFF 1 THRU 99,999.....	1
					UOC:A11,H11	
1	PFOZZ	5995013390190	19207	12340655-1	WIRING HARNESS,BRAN USBL EFF 100,000 AND ABOVE OR VEHICLES WITH SLAVE RECE.....	1
					UOC:A11,A24,A27,B24,H11,H24,H27	
1	PAOZZ	6150014523557	18876	13495871	CABLE ASSEMBLY,POWE.....	1
					UOC:MMM	
2	PAOZZ	5305009897434	96906	MS35207-263	SCREW,MACHINE #10-32 X 1/2.....	5
					UOC:A11,A24,A27,B24,H11,H24,H27,MMM	
3	PAOZZ	5340000572904	96906	MS21333-71	CLAMP,LOOP.....	1
					UOC:A11,A24,A27,B24,H11,H24,H27,MMM	
4	PAOZZ	5310001249265	24617	271169	NUT,PLAIN,ASSEMBLED #10-32.....	6
					UOC:A11,A24,A27,B24,H11,H24,H27,MMM	
5	PAOZZ	5340009899222	96906	MS21333-74	CLAMP,LOOP USBL EFF 100,000 AND ABOVE.....	2
					UOC:A11,A24,A27,B24,H11,H24,H27,MMM	
5	PAOZZ	5340000502740	96906	MS21333-75	CLAMP,LOOP USBL EFF 1 THRU 99,999..	2
					UOC:A11,A24,A27,B24,H11,H24,H27,MMM	
6	PAOZZ	5340000573052	96906	MS21333-114	CLAMP,LOOP.....	1
					UOC:A11,A24,A27,B24,H11,H24,H27,MMM	
7	PAOZZ	5310009334310	24617	271184	NUT,PLAIN,ASSEMBLED 5/16-18.....	2
					UOC:A11,A24,A27,B24,H11,H24,H27,MMM	
8	PAOZZ	5935014572965	18876	13480720	BATTERY PWR SOURCE.....	1
					UOC:MMM	
9	PFOZZ	6150014572964	18876	13493198	CABLE ASSEMBLY,POWE.....	1
					UOC:MMM	
10	PAOZZ	5975008994606	96906	MS3367-2-0	STRAP,TIEDOWN,ELECT.....	V
					UOC:MMM	
11	PAOZZ	5340014766612	19207	12340654	BRACKET,DOUBLE ANGL.....	1
					UOC:A11,A24,A27,B24,H11,H24,H27	
11	PAOZZ	5340014672127	18876	13495916	BRACKET,DOUBLE ANGL.....	1
					UOC:MMM	
12	PAOZZ	5320009572507	96906	MS20604AD6W4	RIVET,BLIND 3/8.....	4
					UOC:MMM	
13	PAOZZ	5935003382822	19207	7261674	COVER,ELECTRICAL CO.....	1
					UOC:A11,A24,A27,B24,H11,H24,H27,MMM	
14	PAOZZ	5305009846195	96906	MS35206-247	SCREW,MACHINE #8-32 X 3/4,USBL EFF 100,000 AND ABOVE.....	4
					UOC:A11,A24,A27,B24,H11,H24,H27,MMM	
14	PAOZZ	5305000545650	10138	15406-022	SCREW,MACHINE #4-40 X 7/16,USBL EFF 1 THRU 99,999.....	4
					UOC:A11,A24,A27,H11,H24,H27,MMM	
15	PAOZZ	5310009338118	70318	S147-1	WASHER,LOCK #4,USBL EFF 1 THRU 99,999.....	4
					UOC:A11,A24,A27,H11,H24,H27,MMM	
16	PAOZZ	5310010695243	72582	271163	NUT,PLAIN,ASSEMBLED #8-32,USBL EFF	4

SECTION II			TM9-2320-280-24P			
(1)	(2)	(3)	(4)	(5)	(6)	(7)
ITEM	SMR			PART		
NO	CODE	NSN	CAGEC	NUMBER	DESCRIPTION AND USABLE ON CODES(UC)	QTY
					100,000 AND ABOVE.....	
					UC:A11,A24,A27,B24,H11,H24,H27,MMM	
16	PAOZZ	5310009349748	27914	S45043-3405	NUT,PLAIN,HEXAGON #4-40,USBL EFF 1	4
					THRU 99,999.....	
					UC:A11,A24,A27,H11,H24,H27,MMM	
17	PAOZZ	5340009588457	96906	MS21333-78	CLAMP,LOOP.....	2
					UC:A11,A24,A27,B24,H11,H24,H27,MMM	

END OF FIGURE

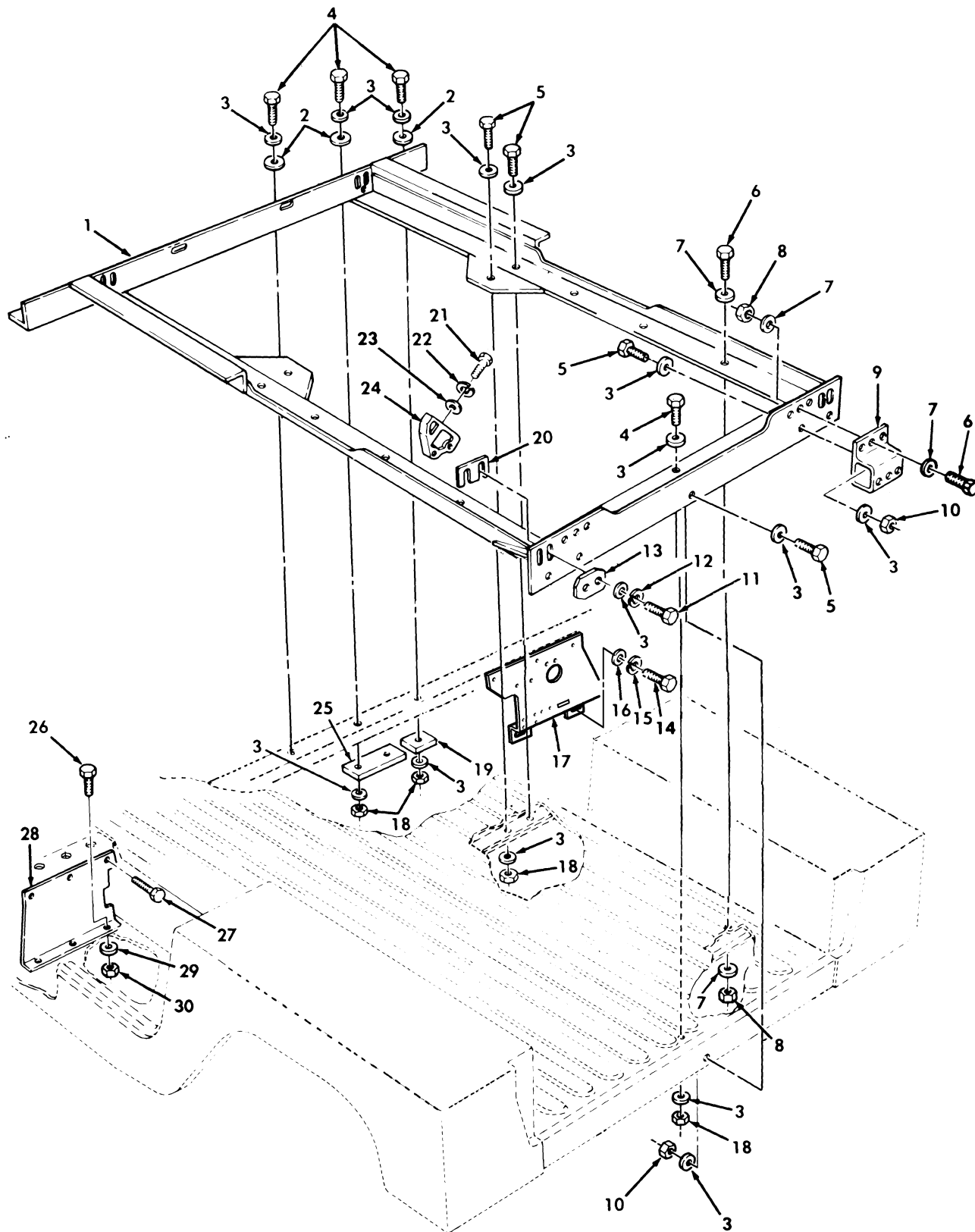

Figure 283. S250 Shelter Mounting Components.

SECTION II			TM9-2320-280-24P			
(1)	(2)	(3)	(4)	(5)	(6)	(7)
ITEM	SMR			PART		
NO	CODE	NSN	CAGEC	NUMBER	DESCRIPTION AND USABLE ON CODES(UOC)	QTY
GROUP 1812 SPECIAL PURPOSE BODIES						
FIG. 283 S250 SHELTER MOUNTING COMPONENTS						
1	PAOZZ	2540012138057	19207	12339875	SUPPORT ASSEMBLY,MO.....	1
					UOC:H21,H28	
2	PAOZZ	5310012110698	19207	12339862-2	WASHER,FLAT 1/2.....	6
					UOC:H21,H28	
3	PAOZZ	5310012538948	34623	5593320	WASHER,FLAT 1/2.....	36
					UOC:H21,H28	
4	PAOZZ	5305000712072	80204	B1821BH050C225N	SCREW,CAP,HEXAGON H 1/2-13 X 2.25..	7
					UOC:H21,H28	
5	PAOZZ	5305000712069	52304	113324	SCREW,CAP,HEXAGON H 1/2-13 X 1.50..	7
					UOC:H21,H28	
6	PAOZZ	5305000680511	80204	B1821BH038C125N	SCREW,CAP,HEXAGON H 3/8-16 X 1.25..	6
					UOC:H21,H28	
7	PAOZZ	5310014124013	24617	2436163	WASHER,FLAT 3/8.....	16
					UOC:H21,H28	
8	PAOZZ	5310009359021	96906	MS51943-35	NUT,SELF-LOCKING,HE 3/8-16.....	6
					UOC:H21,H28	
9	PAOZZ	5340012144675	19207	12338972	BRACKET,MOUNTING.....	2
					UOC:H21,H28	
10	PAOZZ	5310007613706	96906	MS51967-15	NUT,PLAIN,HEXAGON 1/2-13.....	5
					UOC:H21,H28	
11	PAOZZ	5306012761621	34623	5597349	BOLT,SELF-LOCKING 1/2-13 X 2.75....	8
					UOC:H21,H28	
12	PAOZZ	5310000071607	77252	QR816	WASHER,LOCK 1/2.....	8
					UOC:H21,H28	
13	PAOZZ	5365012772387	34623	12341968	SPACER,PLATE.....	4
					UOC:H21,H28	
14	PAOZZ	5310004883889	96906	MS51943-39	NUT,SELF-LOCKING,HE 1/2-13.....	11
					UOC:H21,H28	
15	PFOZZ	2590012131629	34623	12339857	PLATE,REINFORCEMENT.....	2
					UOC:H21,H28	
16	PAOZZ	5365012658939	19207	12341967-3	SPACER,PLATE REAR,.03.....	V
					UOC:H21,H28	
16	PAOZZ	5365012658937	34623	5597351	SPACER,PLATE REAR,.09.....	V
					UOC:H21,H28	
16	PAOZZ	5365012658938	34623	12341967-2	SPACER,PLATE REAR,.12.....	V
					UOC:H21,H28	
17	PAOZZ	5306013601123	24617	9423557	BOLT,MACHINE 7/16-14 X 2.50.....	4
					UOC:H21,H28	
18	PAOZZ	5310010169348	96906	MS51848-13	WASHER,LOCK 7/16.....	4
					UOC:H21,H28	
19	PAOZZ	5310012789555	34623	5593318	WASHER,FLAT 7/16.....	4
					UOC:H21,H28	
20	PAOZZ	5340012658905	19207	12341969	BRACKET,MOUNTING.....	4
					UOC:H21,H28	
21	PFOZZ	2590012131628	19207	12339856	PLATE,REINFORCEMENT.....	2
					UOC:H21,H28	
22	PAOZZ	5305004703321	96906	MS51849-74	SCREW,MACHINE #10-24 X 1/2.....	6
					UOC:H21,H28	



SECTION II			TM9-2320-280-24P			
(1)	(2)	(3)	(4)	(5)	(6)	(7)
ITEM	SMR			PART		
NO	CODE	NSN	CAGEC	NUMBER	DESCRIPTION AND USABLE ON CODES(UOC)	QTY
23	PAOZZ	5305012729042	34623	5593409	SCREW,CAP,HEXAGON H #10-24 X 1/2...	6
					UOC:H21,H28	
24	PAOZZ	2590012039874	19207	12339036	PANEL,CAB SHELTER L.H.,USBL EFF 1	1
					THRU 99,999.....	
					UOC:H21,H28	
24	PAOZZ	2510013357343	19207	12339043-3	PANEL,BODY,VEHICULA R.H.,USBL EFF	1
					100,000 AND ABOVE.....	
					UOC:H21,H28	
24	PAOZZ	2590012039875	19207	12339043-1	PANEL,CABSHELTER,RI R.H.,USBL EFF	1
					1 THRU 99,999.....	
					UOC:H21,H28	
24	PAOZZ	2510013835444	19207	12339036-1	PANEL,BODY,VEHICULA L.H.,USBL EFF	1
					100,000 AND ABOVE.....	
					UOC:H21,H28	
25	PAOZZ	5310000453296	96906	MS35338-43	WASHER,LOCK #10.....	6
					UOC:H21,H28	
26	PAOZZ	5310009349758	96906	MS35649-202	NUT,PLAIN,HEXAGON #10-24.....	6
					UOC:H21,H28	

END OF FIGURE

3 — 

4 thru 11
-----------------

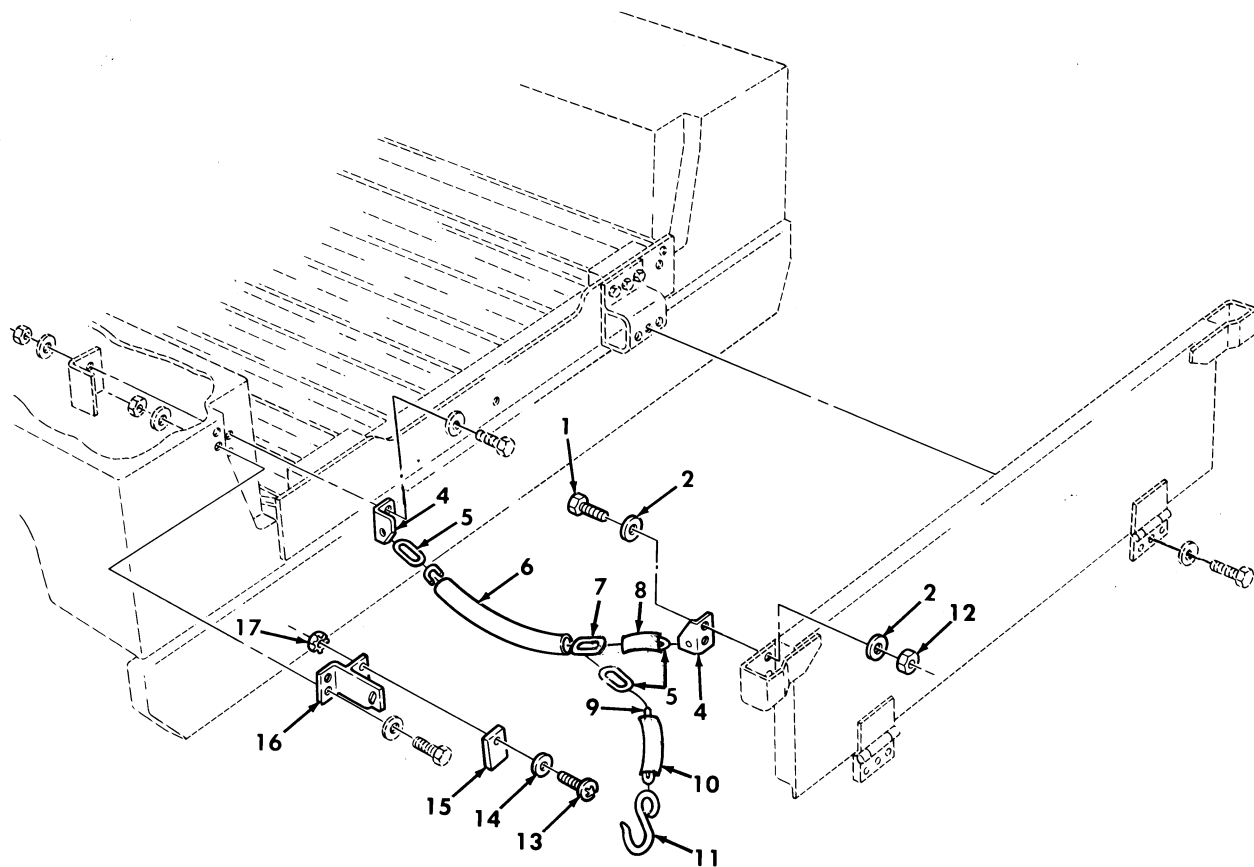

Figure 284. S250 Shelter Tailgate Mounting Components.

SECTION II			TM9-2320-280-24P			
(1)	(2)	(3)	(4)	(5)	(6)	(7)
ITEM	SMR			PART		
NO	CODE	NSN	CAGEC	NUMBER	DESCRIPTION AND USABLE ON CODES(UOC)	QTY
GROUP 1812 SPECIAL PURPOSE BODIES						
FIG. 284 S250 SHELTER TAILGATE MOUNTING COMPONENTS						
1	PAOZZ	5306002264828	80204	B1821BH031C113N	BOLT,MACHINE 5/16-18 X 1-1/8.....	4
					UOC:H21,H28	
2	PAOZZ	5310012520512	34623	5592832	WASHER,FLAT 5/16.....	8
					UOC:H21,H28	
3	PFOZZ	4010012177086	34623	12339229-1	CHAIN ASSEMBLY,SING L.H.....	1
					UOC:H21,H28	
3	PFOZZ	4010012157466	34623	12339229-2	CHAIN ASSEMBLY,SING R.H.....	1
					UOC:H21,H28	
4	PAOZZ	5340011861280	34623	5575702	.BRACKET,ANGLE L.H.....	1
					UOC:H21,H28	
4	PAOZZ	5340011861281	34623	5575703	.BRACKET,ANGLE R.H.....	1
					UOC:H21,H28	
5	PAOZZ	4010011948546	19207	12339223	.LINK,CHAIN,LAP.....	3
					UOC:H21,H28	
6	PAOZZ	2510012528461	34623	5592725	.COVER,CHAIN,TAILGAT.....	1
					UOC:H21,H28	
7	PAOZZ	4010012184639	19207	12339224-1	.CHAIN,WELDED.....	1
					UOC:H21,H28	
8	PAOZZ	2510012527903	34623	5592726	.COVER,CHAIN,TAILGAT.....	1
					UOC:H21,H28	
9	PAOZZ	4010012184640	19207	12339224-2	.CHAIN,WELDED.....	1
					UOC:H21,H28	
10	PAOZZ	2510012527904	34623	5592727	.COVER,CHAIN,TAILGAT.....	1
					UOC:H21,H28	
11	PAOZZ	4030012553634	19207	12339225-1	.HOOK,CHAIN,S R.H.....	1
					UOC:H21,H28	
11	PAOZZ	4030012691263	19207	12339225-2	.HOOK,CHAIN,S L.H.....	1
					UOC:H21,H28	
12	PAOZZ	5310008140673	96906	MS51943-33	NUT,SELF-LOCKING,HE 5/16-18.....	4
					UOC:H21,H28	
13	PAOZZ	5305009846212	96906	MS35206-265	SCREW,MACHINE #10-24 X .75.....	4
					UOC:H21,H28	
14	PAOZZ	5310012349416	96906	MS51412-2	WASHER,FLAT #10.....	4
					UOC:H21,H28	
15	PAOZZ	5342012147809	19207	12338976	MOUNT,RESILIENT.....	2
					UOC:H21,H28	
16	PAOZZ	2540012096875	19207	12338978-2	LATCH,DOOR,VEHICULA L.H.....	1
					UOC:H21,H28	
16	PAOZZ	2540013141121	34623	5590669	LATCH,DOOR,VEHICULA R.H.....	1
					UOC:H21,H28	
17	PAOZZ	5310012538928	34623	5592995	NUT,PLAIN,EXTENDED #10-24.....	4
					UOC:H21,H28	

END OF FIGURE

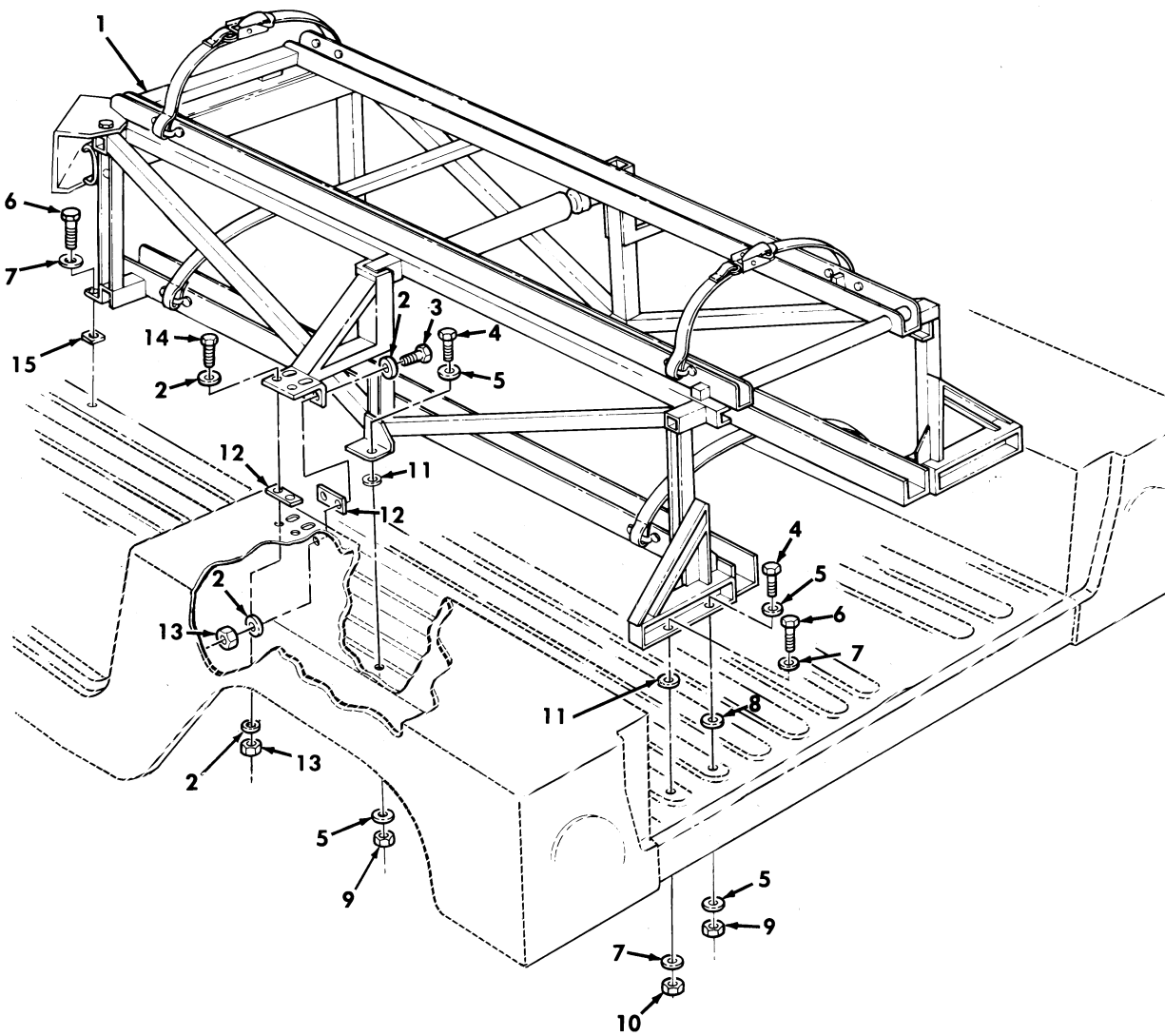

Figure 285. Litter Assembly and Mounting Components.

SECTION II			TM9-2320-280-24P			
(1)	(2)	(3)	(4)	(5)	(6)	(7)
ITEM	SMR			PART		
NO	CODE	NSN	CAGEC	NUMBER	DESCRIPTION AND USABLE ON CODES(UOC)	QTY
GROUP 1812 SPECIAL PURPOSE BODIES						
FIG. 285 LITTER ASSEMBLY AND MOUNTING COMPONENTS						
1	PBOOO	2590011995425	19207	12339959	LITTER SUPPORT,VEHI.....	1
					UOC:A20,B20,H20	
2	PAOZZ	5310011023270	24617	2436161	WASHER,FLAT 1/4.....	24
					UOC:A20,B20,H20	
3	PAOZZ	5305000680509	80204	B1821BH025C125N	SCREW,CAP,HEXAGON H 1/4-20 X 1.25..	4
					UOC:A20,B20,H20	
4	PAOZZ	5305008213869	80204	B1821BH038C175N	SCREW,CAP,HEXAGON H 3/8-16 X 1.75..	4
					UOC:A20,B20,H20	
5	PAOZZ	5310000877493	96906	MS27183-13	WASHER,FLAT 3/8.....	8
					UOC:A20,B20,H20	
6	PAOZZ	5305000712071	80204	B1821BH050C200N	SCREW,CAP,HEXAGON H 1/2-13 X 2.00..	4
					UOC:A20,B20,H20	
7	PAOZZ	5310011211703	06032	2310-0143-001	WASHER,FLAT 1/2.....	6
					UOC:A20,B20,H20	
8	PAOZZ	5365012189914	19207	12338521-5	SPACER,SLEEVE.....	4
					UOC:A20,B20,H20	
9	PAOZZ	5310009359021	96906	MS51943-35	NUT,SELF-LOCKING,HE 3/8-16.....	4
					UOC:A20,B20,H20	
10	PAOZZ	5310007613706	96906	MS51967-15	NUT,PLAIN,HEXAGON 1/2-13.....	2
					UOC:A20,B20,H20	
11	PAOZZ	5365012189914	19207	12338521-5	SPACER,SLEEVE.....	4
					UOC:A20,B20,H20	
12	PFOZZ	5365012189848	34623	5583066	SPACER,PLATE.....	4
					UOC:A20,B20,H20	
13	PAOZZ	5310000614650	96906	MS51943-31	NUT,SELF-LOCKING,HE 1/4-20.....	8
					UOC:A20,B20,H20	
14	PAOZZ	5305002253843	80204	B1821BH025C100N	SCREW,CAP,HEXAGON H 1/4-20 X 1.00..	8
					UOC:A20,B20,H20	
15	PAOZZ	5365012553610	19207	12339913	SPACER,PLATE.....	2
					UOC:A20,B20,H20	

END OF FIGURE

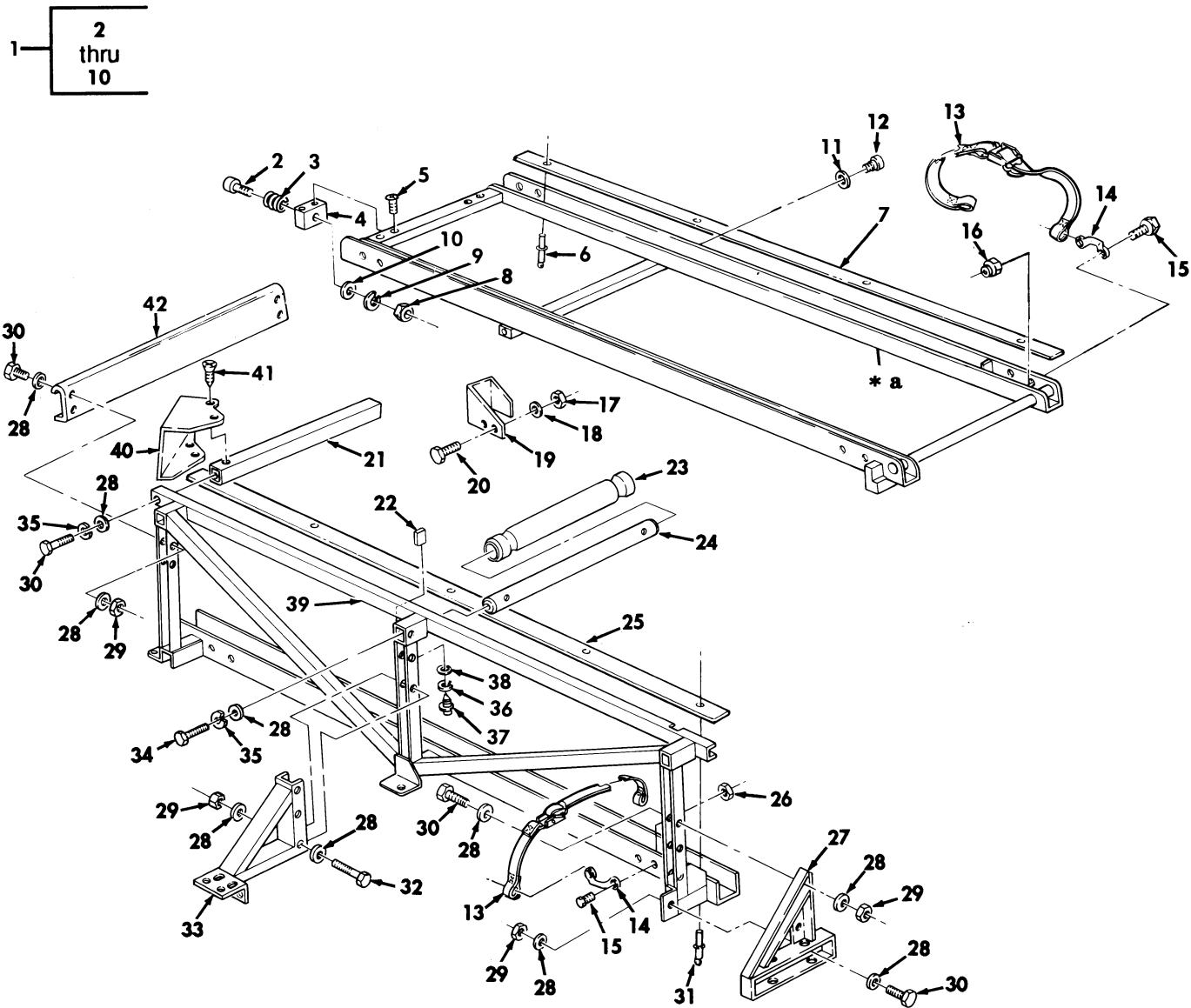

Figure 286. Litter Assembly.

SECTION II			TM9-2320-280-24P			
(1)	(2)	(3)	(4)	(5)	(6)	(7)
ITEM NO	SMR CODE	NSN	CAGEC	PART NUMBER	DESCRIPTION AND USABLE ON CODES(UOC)	QTY
GROUP 1812 SPECIAL PURPOSE BODIES						
FIG. 286 LITTER ASSEMBLY						
1	PFOZZ	2590012175743	19207	12339957	TRAY ASSEMBLY,LITTE.....	1
					UOC:A20,B20,H20	
2	PAOZZ	5305012217734	58132	08084	.SCREW,SHOULDER 3/8-16 X 2.50.....	2
					UOC:A20,B20,H20	
3	PAOZZ	5360012181608	73821	C0720-081-1500S	.SPRING,HELICAL,COMP.....	2
					UOC:A20,B20,H20	
4	PFOZZ	5340011975469	19207	12339916	.PLATE,MOUNTING.....	2
					UOC:A20,B20,H20	
5	PAOZZ	5305012241449	58132	64046	.SCREW,CAP,SOCKET HE 1/4-20 X 3/4..	4
					UOC:A20,B20,H20	
6	PAOZZ	5320012197261	34623	5590150	.RIVET,BLIND.....	8
					UOC:A20,B20,H20	
7	PAOZZ	2540013890984	34623	12339942	.TRACK,LITTER.....	2
					UOC:A20,B20,H20	
8	PAOZZ	5310007610654	96906	MS51967-9	.NUT,PLAIN,HEXAGON 3/8-16.....	2
					UOC:A20,B20,H20	
9	PAOZZ	5310006379541	96906	MS35338-46	.WASHER,LOCK 3/8.....	2
					UOC:A20,B20,H20	
10	PAOZZ	5310000877493	96906	MS27183-13	.WASHER,FLAT 3/8.....	2
					UOC:A20,B20,H20	
11	PAOZZ	5310012203099	34623	5577458	WASHER,FLAT 1/4.....	2
					UOC:A20,B20,H20	
12	PAOZZ	3110001623766	60380	CRS22CP	CAM FOLLOWER,NEEDLE.....	2
					UOC:A20,B20,H20	
13	PAOZZ	5340012609940	31272	44648-24	STRAP,WEBBING.....	4
					UOC:A20,B20,H20	
14	PAOZZ	5340004895684	19220	6411-B	LOOP,STRAP FASTENER.....	8
					UOC:A20,B20,H20	
15	PAOZZ	5305002400194	96906	MS51849-76	SCREW,MACHINE #10-24 X 3/4.....	16
					UOC:A20,B20,H20	
16	PAOZZ	5310009349764	96906	MS35649-205	NUT,PLAIN,HEXAGON #10-24.....	8
					UOC:A20,B20,H20	
17	PAOZZ	5310000614650	96906	MS51943-31	NUT,SELF-LOCKING,HE 1/4-20.....	3
					UOC:A20,B20,H20	
18	PAOZZ	5310012538949	34623	5592926	WASHER,FLAT 1/4.....	3
					UOC:A20,B20,H20	
19	PAOZZ	2590012491588	19207	12340779	LITTER STOP,LOWER T.....	1
					UOC:A20,B20,H20	
20	PAOZZ	5305000680501	96906	MS90725-5	SCREW,CAP,HEXAGON H 1/4-20 X 5/8...	3
					UOC:A20,B20,H20	
21	PAOZZ	2540012172666	19207	12339925	BUMPER,VEHICULAR.....	1
					UOC:A20,B20,H20	
22	PAOZZ	5310012283299	19207	12339924	NUT,SLEEVE.....	4
					UOC:A20,B20,H20	
23	PAOZZ	4710012179959	19207	12339912	TUBING,NONMETALLIC.....	1
					UOC:A20,B20,H20	
24	PAOZZ	2590012172665	19207	12339921	SUPPORT,ROUND,LITTE.....	1
					UOC:A20,B20,H20	
25	PAOZZ	2540013836470	19207	12339951	SLIDE,LOWER TRACK.....	2

SECTION II			TM9-2320-280-24P			
(1)	(2)	(3)	(4)	(5)	(6)	(7)
ITEM	SMR			PART		
NO	CODE	NSN	CAGEC	NUMBER	DESCRIPTION AND USABLE ON CODES(UC)	QTY
					UOC:A20,B20,H20	
26	PAOZZ	5310002081918	24617	190254	NUT,SELF-LOCKING,HE #10-24.....	8
					UOC:A20,B20,H20	
27	PFOZZ	5340012172576	19207	12339954-2	BRACE,CORNER LOWER REAR,R.H.....	1
					UOC:A20,B20,H20	
27	PFOZZ	5340012172667	19207	12339954-1	BRACE,CORNER LOWER REAR,L.H.....	1
					UOC:A20,B20,H20	
28	PAOZZ	5310012538438	34623	5593218	WASHER,FLAT 3/8.....	42
					UOC:A20,B20,H20	
29	PFOZZ	5310009359021	96906	MS51943-35	NUT,SELF-LOCKING,HE 3/8-16.....	18
					UOC:A20,B20,H20	
30	PAOZZ	5305000680510	80204	B1821BH038C100N	SCREW,CAP,HEXAGON H 3/8-16 X 1.00..	14
					UOC:A20,B20,H20	
31	PAOZZ	5320012185802	34623	5590149	RIVET,BLIND.....	5
					UOC:A20,B20,H20	
32	PAOZZ	5305007813926	80204	B1821BH038C275N	SCREW,CAP,HEXAGON H 3/8-16 X 2.75..	6
					UOC:A20,B20,H20	
33	PFOZZ	2510012172663	19207	12339947-1	SUPPORT,CENTER,WHEEL L.H.....	1
					UOC:A20,B20,H20	
33	PFOZZ	2510012172664	19207	12339947-2	SUPPORT,CENTER,WHEEL R.H.....	1
					UOC:A20,B20,H20	
34	PAOZZ	5305007252317	80204	B1821BH038C150N	SCREW,CAP,HEXAGON H 3/8-16 X 1.50..	2
					UOC:A20,B20,H20	
35	PAOZZ	5310006379541	96906	MS35338-46	WASHER,LOCK 3/8.....	4
					UOC:A20,B20,H20	
36	PAOZZ	5310005825965	96906	MS35338-44	WASHER,LOCK 1/4.....	2
					UOC:A20,B20,H20	
37	PAOZZ	5305002253843	80204	B1821BH025C100N	SCREW,CAP,HEXAGON H 1/4-20 X 1.00..	2
					UOC:A20,B20,H20	
38	PAOZZ	5310011023270	24617	2436161	WASHER,FLAT 1/4.....	2
					UOC:A20,B20,H20	
39	PFOZZ	2590011975474	19207	12339958-1	TRACK,LITTER SUPPOR L.H.....	1
					UOC:A20,B20,H20	
39	PFOZZ	2590011975475	19207	12339958-2	TRACK,LITTER SUPPOR R.H.....	1
					UOC:A20,B20,H20	
40	PAOZZ	2590012489536	19207	12339952	SHIELD,LITTER RACK UPPER FRONT,L.H.	1
					UOC:A20,B20,H20	
40	PAOZZ	2590012489531	34623	5594676	SHIELD,LITTER RACK UPPER FRONT R.H.	1
					UOC:A20,B20,H20	
41	PAOZZ	5305012596322	34623	12342499-1	SCREW,MACHINE #10-32 X .50.....	8
					UOC:A20,B20,H20	
42	PAOZZ	2590012328210	19207	12339944	BRACKET,LITTER.....	1
					UOC:A20,B20,H20	

END OF FIGURE



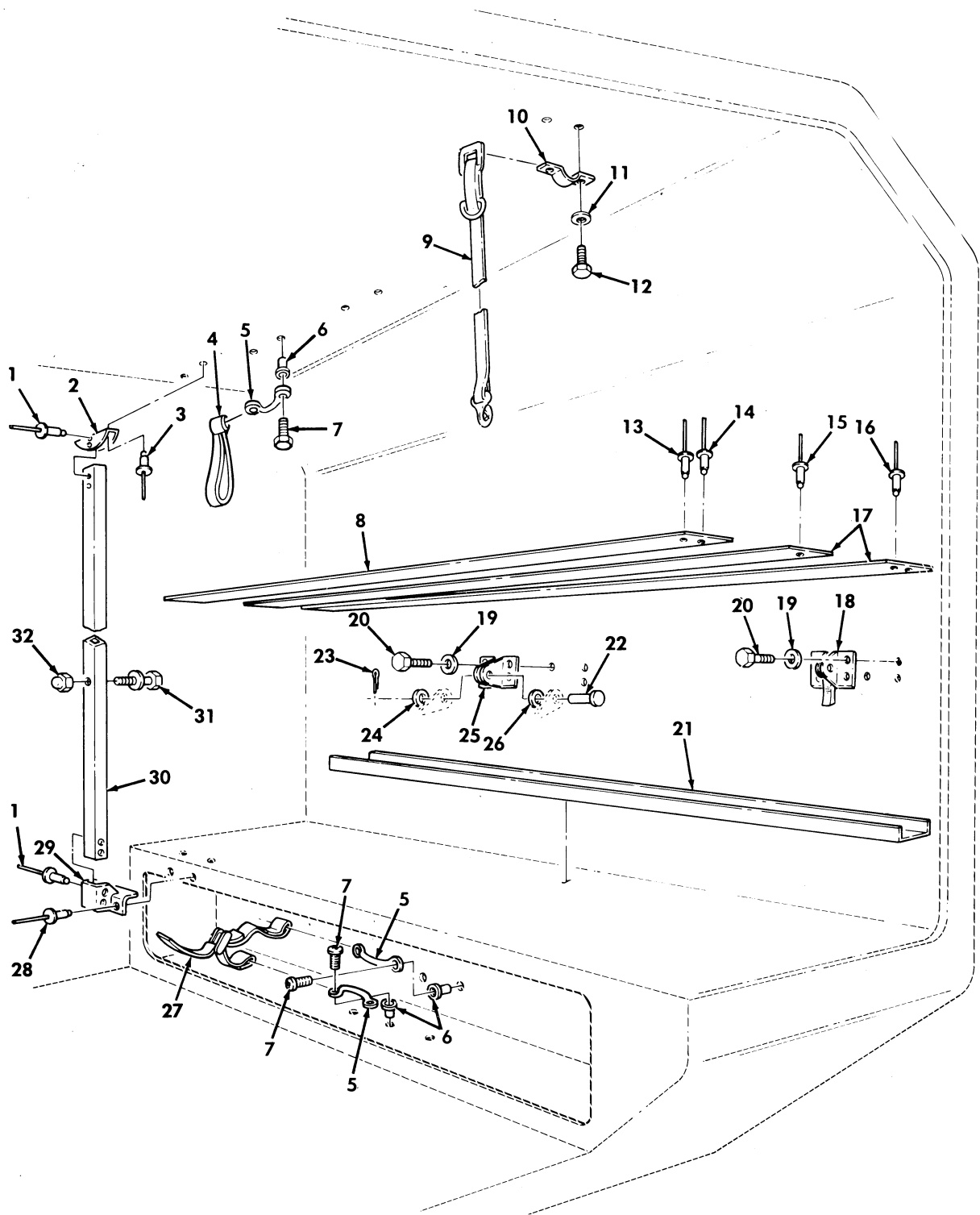

Figure 287. Lower Litter Skids and Upper Litter Mounting Hardware, M997, M997A1, and M997A2 Ambulance.

SECTION II			TM9-2320-280-24P			
(1)	(2)	(3)	(4)	(5)	(6)	(7)
ITEM	SMR			PART		
NO	CODE	NSN	CAGEC	NUMBER	DESCRIPTION AND USABLE ON CODES(UC)	QTY
GROUP 1812 SPECIAL PURPOSE BODIES						
FIG. 287 LOWER LITTER SKIDS AND UPPER LITTER MOUNTING HARDWARE,M997, M997A1,AND M997A2 AMBULANCE						
1	PAOZZ	5320011361782	11815	CR3213-6-4	RIVET,BLIND 3/16.....	8
					UOC:A15,B15,H15	
2	PFOZZ	5340012727495	19207	12341496	BRACKET,DOUBLE ANGL.....	2
					UOC:A15,B15,H15	
3	PAOZZ	5320010849235	11815	CR-213-6-5	RIVET,BLIND 3/16.....	4
					UOC:A15,B15,H15	
4	PAOZZ	5340013658796	19207	12341384	STRAP,WEBBING.....	4
					UOC:A15,B15,H15	
5	PAOZZ	5340013145957	19207	12338839-1	LOOP,STRAP FASTENER.....	6
					UOC:A15,B15,H15	
6	PAOZZ	5310011976253	25472	S10P320	NUT,PLAIN,BLIND RIV #10-32.....	12
					UOC:A15,B15,H15	
7	PAOZZ	5305011850114	7X677	157166	SCREW #10-32 X 3/4.....	12
					UOC:A15,B15,H15	
8	PFOZZ	9330012761470	34623	SF5934157	MOLDING,PLASTIC.....	2
					UOC:A15,B15,H15	
9	PAOZZ	5340012663846	31272	45085-11	STRAP,WEBBING.....	2
					UOC:A15,B15,H15	
10	PFOZZ	5340012723402	31272	45094-10	STRAP,RETAINING.....	2
					UOC:A15,B15,H15	
11	PAOZZ	5310005825965	96906	MS35338-44	WASHER,LOCK 1/4.....	4
					UOC:A15,B15,H15	
12	PAOZZ	5305000680508	80204	B1821BH025C075N	SCREW,CAP,HEXAGON H 1/4-20 X .75...	4
					UOC:A15,B15,H15	
13	PAOZZ	5320010861148	80205	NAS9302BNS-6-06	RIVET,BLIND 3/16.....	18
					UOC:A15,B15,H15	
14	PAOZZ	5320011361785	11815	CR-212-6-4	RIVET,BLIND 3/16.....	20
					UOC:A15,B15,H15	
15	PAOZZ	5320012730020	11815	CR-212-6-5	RIVET,BLIND 3/16.....	30
					UOC:A15,B15,H15	
16	PAOZZ	5320010861147	11815	CR3212-6-7	RIVET,BLIND 3/16.....	30
					UOC:A15,B15,H15	
17	PFOZZ	9330012697114	19207	12341320-6	PLASTIC STRIP.....	4
					UOC:A15,B15,H15	
18	PAOZZ	5340012663844	31272	44996-10	BUCKLE.....	2
					UOC:A15,B15,H15	
19	PAOZZ	5310004079566	96906	MS35338-45	WASHER,LOCK 5/16.....	16
					UOC:A15,B15,H15	
20	PAOZZ	5306002264827	80204	B1821BH031C100N	BOLT,MACHINE 5/16-18 X 1.00.....	16
					UOC:A15,B15,H15	
21	PFOZZ	2540012756202	34623	12341076	TRACK,LOWER LITTER.....	4
					UOC:A15,B15,H15	
22	PAOZZ	5315012730096	19207	12341354	PIN,STRAIGHT,HEADED 1/4.....	4
					UOC:A15,B15,H15	
23	PAOZZ	5315012806185	70655	10392	PIN,LOCK 1-35/64.....	4
					UOC:A15,B15,H15	
24	PAOZZ	5310008094058	96906	MS27183-10	WASHER,FLAT 1/4.....	4

SECTION II			TM9-2320-280-24P			
(1)	(2)	(3)	(4)	(5)	(6)	(7)
ITEM	SMR			PART		
NO	CODE	NSN	CAGEC	NUMBER	DESCRIPTION AND USABLE ON CODES (UOC)	QTY
25	PFOZZ	5340012734667	34623	5589868	UOC:A15,B15,H15 BRACKET,MOUNTING.....	2
26	PAOZZ	5310012727449	19207	12341353-1	UOC:A15,B15,H15 WASHER,FLAT 3/8.....	4
27	PAOZZ	5340012658923	19207	12339817-4	UOC:A15,B15,H15 STRAP,WEBBING.....	1
28	PAOZZ	5320010859995	11815	CR3213-6-7	UOC:A15,B15,H15 RIVET,BLIND 3/16.....	8
29	PFOZZ	5340012725594	34623	5589864	UOC:A15,B15,H15 BRACKET,MOUNTING.....	2
30	PFOZZ	4710012717937	19207	12341049	UOC:A15,B15,H15 TUBE,METALLIC.....	2
31	PAOZZ	5306012658897	27182	J4501XXBZ01	UOC:A15,B15,H15 BOLT,SHOULDER.....	2
32	PAOZZ	5310012726546	34623	5593387	UOC:A15,B15,H15 NUT,PLAIN,CAP 7/16-14.....	2

END OF FIGURE

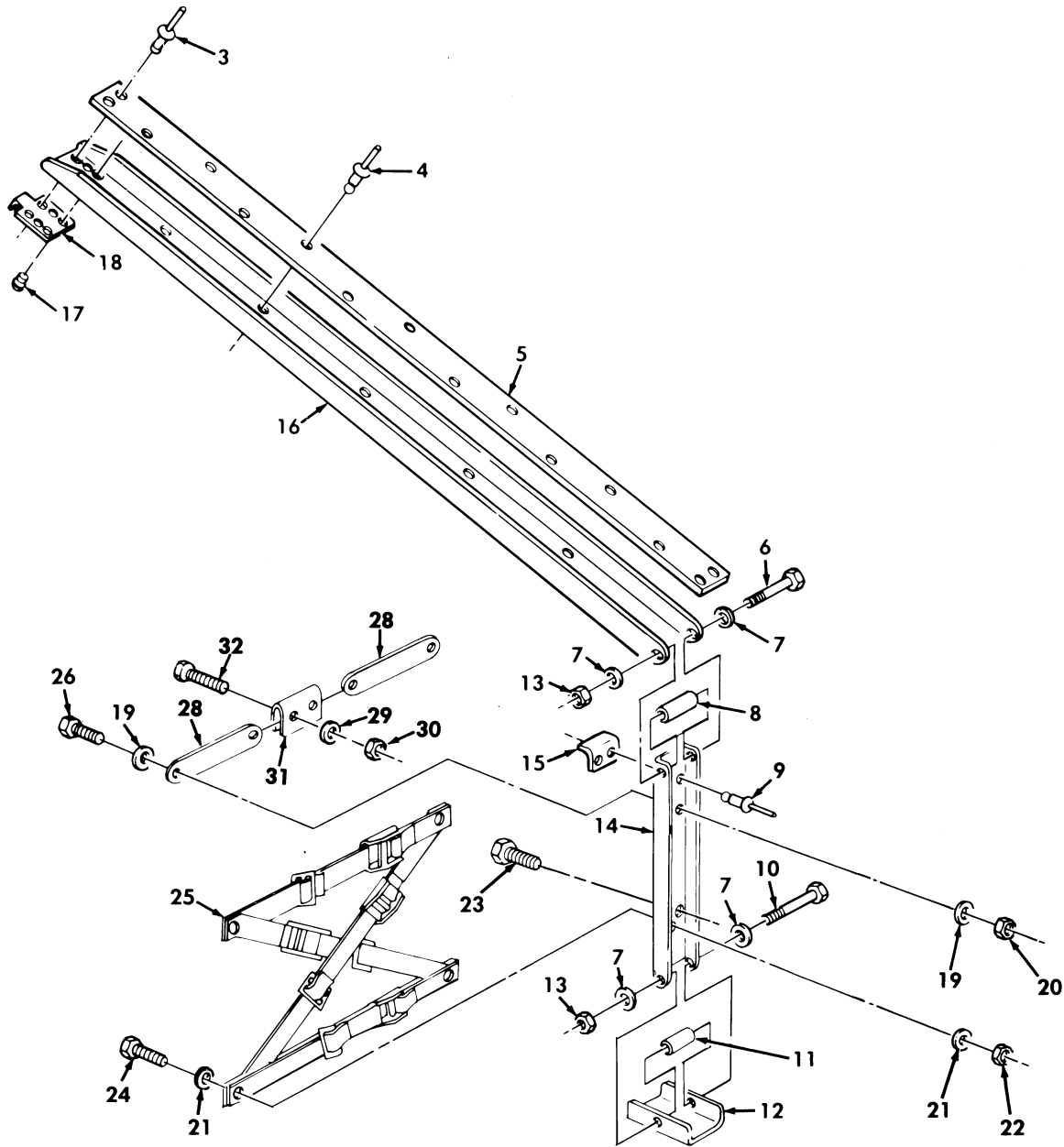
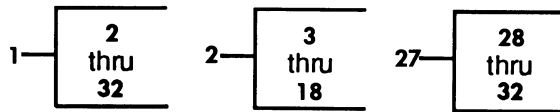

Figure 288. Litter Tray Extension Assembly, M997, M997A1, and M997A2 Ambulance.

SECTION II			TM9-2320-280-24P			
(1)	(2)	(3)	(4)	(5)	(6)	(7)
ITEM NO	SMR CODE	NSN	CAGEC	PART NUMBER	DESCRIPTION AND USABLE ON CODES(UOC)	QTY
GROUP 1812 SPECIAL PURPOSE BODIES						
FIG. 288 LITTER TRAY EXTENSION ASSEMBLY,M997,M997A1,AND M997A2 AMBULANCE						
1	PFOZZ	2540013578939	34623	12340946	EXTENSION ASSEMBLY,.....	1
					UOC:A15,B15,H15	
2	AOOOO		34623	5588872	.TRAY ASSEMBLY R.H.....	1
					UOC:A15,B15,H15	
2	AOOOO		34623	5589785	.TRAY ASSEMBLY L.H.....	1
					UOC:A15,B15,H15	
3	PAOZZ	5320011361787	11815	CR3212-6-5	..RIVET,BLIND 3/16 X 7/16.....	8
					UOC:A15,B15,H15	
4	PAOZZ	5320001177289	96906	MS20426AD6-9	..RIVET,SOLID 3/16 X 5/16.....	26
					UOC:A15,B15,H15	
5	PFOZZ	2540012713772	19207	12341012	..RAIL SKID,EXTENSION.....	2
					UOC:A15,B15,H15	
6	PAOZZ	5305007813928	80204	B1821BH038C400N	..SCREW,CAP,HEXAGON H 3/8-16 X 4.00	2
					UOC:A15,B15,H15	
7	PAOZZ	5310000877493	96906	MS27183-13	..WASHER,FLAT 3/8.....	8
					UOC:A15,B15,H15	
8	PFOZZ	4710012709507	19207	12341582-2	..TUBE,METALLIC.....	2
					UOC:A15,B15,H15	
9	PAOZZ	5320007219062	80205	MS20470AD6-10	..RIVET,SOLID 3/16 X 3/8.....	4
					UOC:A15,B15,H15	
10	PAOZZ	5305007813927	80204	B1821BH038C350N	..SCREW,CAP,HEXAGON H 3/8-16 X 3.50	2
					UOC:A15,B15,H15	
11	PAOZZ	4710005414935	19207	12341582-1	..TUBE,METALLIC.....	2
					UOC:A15,B15,H15	
12	PFOZZ	2510012723951	19207	12341020	..FRAME SECTION,STRUC.....	2
					UOC:A15,B15,H15	
13	PAOZZ	5310009359021	96906	MS51943-35	..NUT,SELF-LOCKING,HE 3/8-16.....	4
					UOC:A15,B15,H15	
14	PFOZZ	2510012723952	19207	12341556-2	..FRAME SECTION,STRUC R.H.....	1
					UOC:A15,B15,H15	
14	PFOZZ	2510012720538	19207	12341556-1	..FRAME SECTION,STRUC L.H.....	1
					UOC:A15,B15,H15	
15	PFOZZ	2540012756203	34623	5588878	..LEG,STOP.....	2
					UOC:A15,B15,H15	
16	PFOZZ	2510012723953	19207	12341112	..FRAME SECTION,STRUC.....	2
					UOC:A15,B15,H15	
17	PAOZZ	5320001176910	96906	MS20426AD10-16	..RIVET,SOLID 5/16 X 1.00.....	8
					UOC:A15,B15,H15	
18	PAOZZ	5340012729105	34623	5597808	..BRACKET,ANGLE R.H.....	1
					UOC:A15,B15,H15	
18	PAOZZ	5340012813429	34623	5588877	..BRACKET,ANGLE L.H.....	1
					UOC:A15,B15,H15	
19	PAOZZ	5310000814219	96906	MS27183-12	.WASHER,FLAT 1/4.....	8
					UOC:A15,B15,H15	
20	PAOZZ	5310008140673	96906	MS51943-33	.NUT,SELF-LOCKING,HE 5/16-18.....	4
					UOC:A15,B15,H15	
21	PAOZZ	5310008094058	96906	MS27183-10	.WASHER,FLAT 5/16.....	8

SECTION II			TM9-2320-280-24P			
(1)	(2)	(3)	(4)	(5)	(6)	(7)
ITEM	SMR			PART		
NO	CODE	NSN	CAGEC	NUMBER	DESCRIPTION AND USABLE ON CODES(UOC)	QTY
					UOC:A15,B15,H15	
22	PAOZZ	5310000614650	96906	MS51943-31	.NUT,SELF-LOCKING,HE 1/4-20.....	4
					UOC:A15,B15,H15	
23	PAOZZ	5305002264831	80204	B1821BH031C150N	.SCREW,CAP,HEXAGON H LOWER ARM,5/ 16-18 X 1.50.....	2
					UOC:A15,B15,H15	
24	PAOZZ	5305000680509	80204	B1821BH025C125N	.SCREW,CAP,HEXAGON H 1/4-20 X 1.00.	4
					UOC:A15,B15,H15	
25	PAOZZ	5342012806264	31272	45243-10	.STRAP ASSEMBLY.....	1
					UOC:A15,B15,H15	
26	PAOZZ	5306002264828	80204	B1821BH031C113N	.BOLT,MACHINE UPPER ARM,5/16 18 X 1.125.....	2
					UOC:A15,B15,H15	
27	PAOZZ	2540012711946	19207	12341132	.ARM ASSEMBLY,RAIL.....	2
					UOC:A15,B15,H15	
28	PAOZZ	2540012713773	34623	5592019	..LOCKING ARM,EXTENSI.....	2
					UOC:A15,B15,H15	
29	PAOZZ	5310008094058	96906	MS27183-10	..WASHER,FLAT 1/4.....	2
					UOC:A15,B15,H15	
30	PAOZZ	5310000614650	96906	MS51943-31	..NUT,SELF-LOCKING,HE 1/4-20.....	2
					UOC:A15,B15,H15	
31	PAOZZ	5340012727493	34623	5592020	..BRACKET,DOUBLE ANGL.....	1
					UOC:A15,B15,H15	
32	PAOZZ	5305000680509	80204	B1821BH025C125N	..SCREW,CAP,HEXAGON H 1/4-20 X 1.25	2
					UOC:A15,B15,H15	

END OF FIGURE

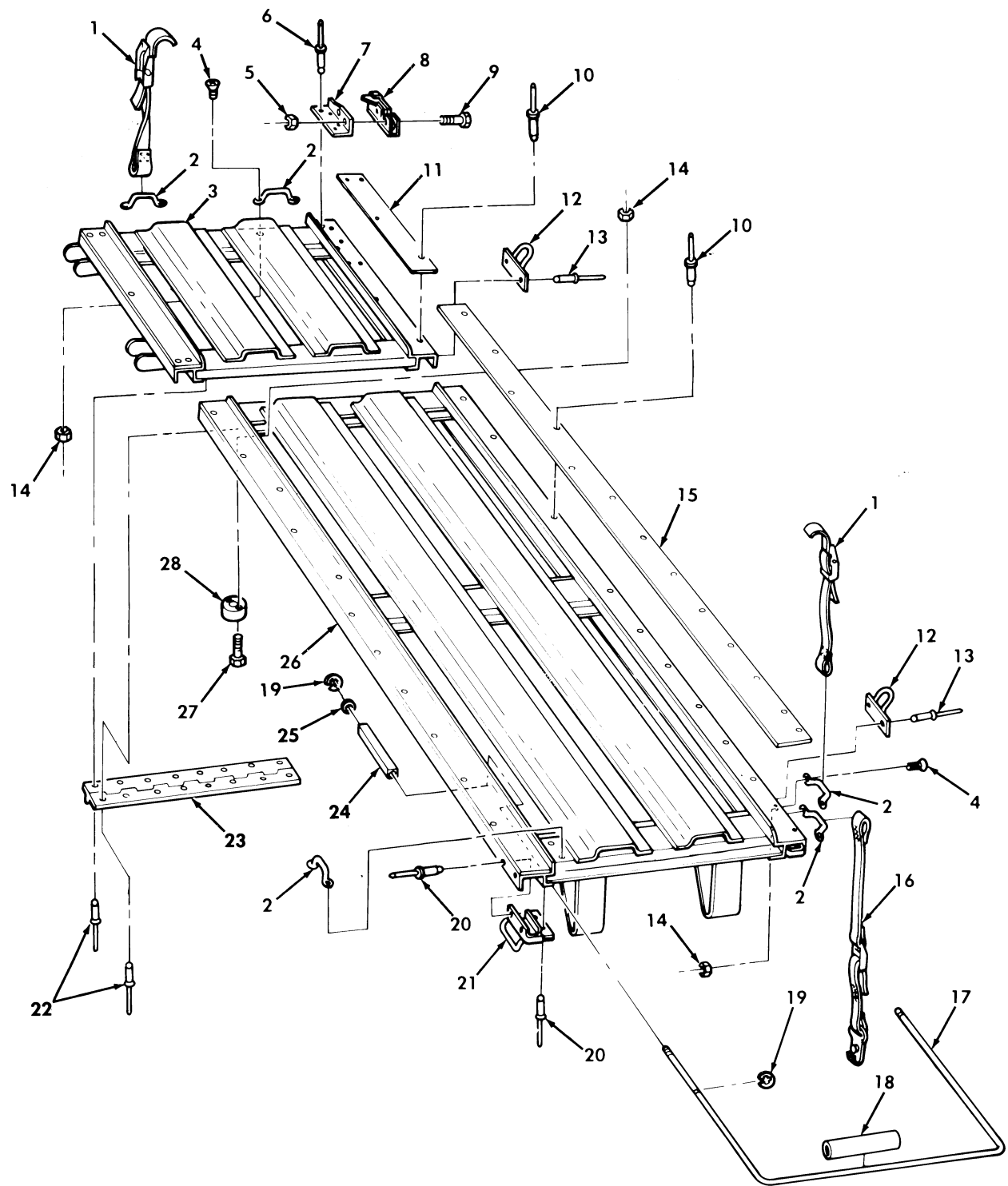

Figure 289. Upper Litter Tray Assembly, M997, M997A1, and M997A2 Ambulance.

SECTION II			TM9-2320-280-24P			
(1)	(2)	(3)	(4)	(5)	(6)	(7)
ITEM NO	SMR CODE	NSN	CAGEC	PART NUMBER	DESCRIPTION AND USABLE ON CODES(UOC)	QTY
GROUP 1812 SPECIAL PURPOSE BODIES						
FIG. 289 UPPER LITTER TRAY ASSEMBLY, M997,M997A1,AND M997A2 AMBULANCE						
1	PAOZZ	5340012658925	31272	45084-11	STRAP,WEBBING.....	8
					UOC:A15,B15,H15	
2	PAOZZ	5340011918186	34623	5582608	HANDLE,BOW.....	10
					UOC:A15,B15,H15	
3	PFOZZ	2540012712840	19207	12341143-1	LITTER TRAY,AMBULAN L.H.....	1
					UOC:A15,B15,H15	
3	PFOZZ	2540012712841	19207	12341143-2	LITTER TRAY,AMBULAN R.H.....	1
					UOC:A15,B15,H15	
4	PAOZZ	5305001804966	96906	MS51849-64	SCREW,MACHINE #10-32 X .50.....	20
					UOC:A15,B15,H15	
5	PAOZZ	5310000614650	96906	MS51943-31	NUT,SELF-LOCKING,HE 1/4-20.....	4
					UOC:A15,B15,H15	
6	PAOZZ	5320011361782	11815	CR3213-6-4	RIVET,BLIND 3/16.....	8
					UOC:A15,B15,H15	
7	PFOZZ	5340012722635	19207	12340952-1	BRACKET,ANGLE L.H.....	1
					UOC:A15,B15,H15	
7	PFOZZ	5340012731680	19207	12340952-2	BRACKET,ANGLE R.H.....	1
					UOC:A15,B15,H15	
8	PAOZZ	2540013857497	27182	J450XXLXBZ01	LATCH,LITTER,VEHICU FRONT,L.H.....	1
					UOC:A15,B15,H15	
8	PAOZZ	5342012667559	27182	S4501XRXBZXX	LATCH,UPPER LITTER FRONT,R.H.....	1
					UOC:A15,B15,H15	
9	PAOZZ	5305000712509	80204	B1821BH025C150N	SCREW,CAP,HEXAGON H FRONT,1/4-20 X 1.50.....	4
					UOC:A15,B15,H15	
10	PAOZZ	5320001177288	96906	MS20426-AD6-8	RIVET,SOLID 3/16.....	68
					UOC:A15,B15,H15	
11	PFOZZ	2540012765928	34623	SF5589377	SKID,TRAY,LITTER.....	4
					UOC:A15,B15,H15	
12	PAOZZ	2540012713771	19207	12340955	RING ASSEMBLY,LITTE.....	4
					UOC:A15,B15,H15	
13	PAOZZ	5320001176853	80205	MS20470AD6-8	RIVET,SOLID 3/16 X 1/4.....	8
					UOC:A15,B15,H15	
14	PAOZZ	5310012510726	34623	5593053	NUT,SELF-LOCKING,HE #10-32.....	28
					UOC:A15,B15,H15	
15	PAOZZ	2540012719806	19207	12341320-4	SKID,UPPER TRAY,REA.....	4
					UOC:A15,B15,H15	
16	PAOZZ	5340012822670	31272	45087-10	STRAP,WEBBING.....	2
					UOC:A15,B15,H15	
17	PAOZZ	5340012728405	19207	12341064	HANDLE,BOW.....	2
					UOC:A15,B15,H15	
18	PAOZZ	5365012722806	19207	12341670	BUSHING,NONMETALLIC.....	2
					UOC:A15,B15,H15	
19	PAOZZ	5325004425845	96906	MS16633-1050	RING,RETAINING.....	8
					UOC:A15,B15,H15	
20	PAOZZ	5320007219062	80205	MS20470AD6-10	RIVET,SOLID 3/16.....	8
					UOC:A15,B15,H15	
21	PFOZZ	5340012725652	19207	12341045-1	STRIKE,CATCH L.H.....	1



SECTION II			TM9-2320-280-24P			
(1)	(2)	(3)	(4)	(5)	(6)	(7)
ITEM	SMR			PART		
NO	CODE	NSN	CAGEC	NUMBER	DESCRIPTION AND USABLE ON CODES(UOC)	QTY
21	PFOZZ	5340012724962	19207	12341045-2	UOC:A15,B15,H15 STRIKE,CATCH R.H.....	1
22	PAOZZ	5320012716357	9K475	MGLP-B6-4	UOC:A15,B15,H15 RIVET,BLIND 3/16.....	32
23	PFOZZ	5340012658858	19207	12341565	UOC:A15,B15,H15 HINGE,BUTT.....	2
24	PFOZZ	5340012724935	34623	5589748-C	UOC:A15,B15,H15 HANDLE,MANUAL CONTR.....	4
25	PAOZZ	5310012729985	19207	12341399	UOC:A15,B15,H15 WASHER,FLAT 3/4.....	4
26	PFOZZ	2590012713770	19207	12341145-1	UOC:A15,B15,H15 TRAY ASSEMBLY,LITTE L.H.....	1
26	PFOZZ	2590012719807	19207	12341145-2	UOC:A15,B15,H15 TRAY ASSEMBLY,LITTE R.H.....	1
27	PAOZZ	5305012725433	3M915	5593390	UOC:A15,B15,H15 SCREW,MACHINE #10-32 X 1.00.....	8
28	PAOZZ	6230012698054	0VDA9	922-721-00	UOC:A15,B15,H15 STAND,LIGHT.....	4
					UOC:A15,B15,H15	

END OF FIGURE

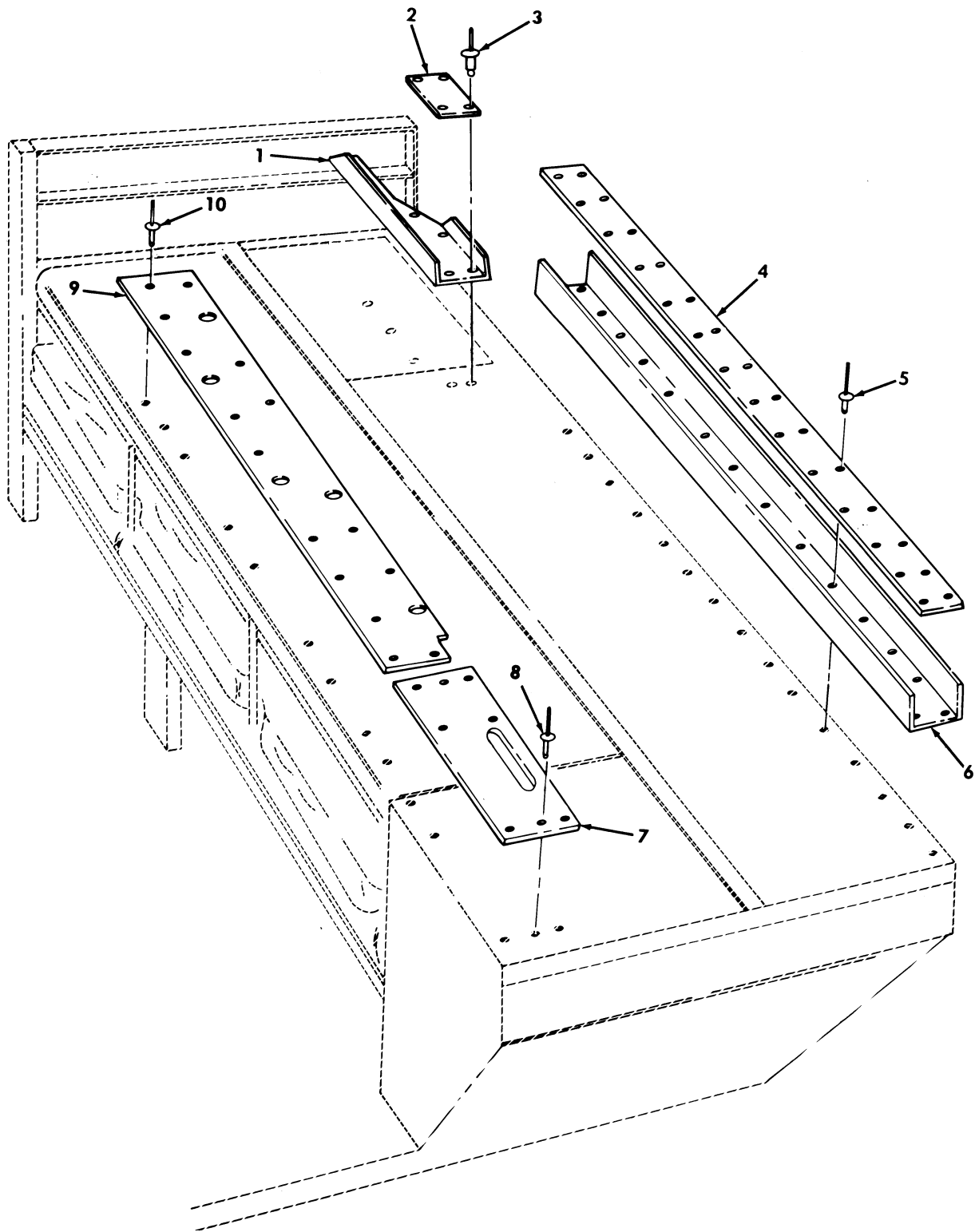

Figure 290. Litter Skids and Tracks, M996 and M996A1 Ambulance.

SECTION II			TM9-2320-280-24P			
(1)	(2)	(3)	(4)	(5)	(6)	(7)
ITEM	SMR			PART		
NO	CODE	NSN	CAGEC	NUMBER	DESCRIPTION AND USABLE ON CODES(UC)	QTY
GROUP 1812 SPECIAL PURPOSE BODIES						
FIG. 290 LITTER SKIDS AND TRACKS, M996 AND M996A1 AMBULANCE						
1	PFOZZ	5340012765850	34623	5597602	BRACKET,DOUBLE ANGL FRONT,L.H..... UOC:B16,H16	1
1	PFOZZ	5342012746210	34623	5597603	TRACK,LITTER,FRONT, FRONT,R.H..... UOC:B16,H16	1
2	PFOZZ	2540012712832	34623	SF5597606	SKID,COVER..... UOC:B16,H16	2
3	PAOZZ	5320010861148	80205	NAS9302BNS-6-06	RIVET,BLIND 3/16 X 1/8..... UOC:B16,H16	8
4	PFOZZ	2540012706458	19207	12341320-2	SKID,COVER REAR..... UOC:B16,H16	2
5	PAOZZ	5320011361787	80205	NAS9302BNS-6-05	RIVET,BLIND 3/16..... UOC:B16,H16	56
6	PFOZZ	5340012731686	19207	12341507	BRACKET,DOUBLE ANGL LITTER, REAR... UOC:B16,H16	2
7	PFOZZ	2540012706459	34623	SF5934158	SKID,COVER REAR..... UOC:B16,H16	2
8	PAOZZ	5320011361785	11815	CR-212-6-4	RIVET,BLIND 3/16 X 1/4..... UOC:B16,H16	16
9	PFOZZ	2540012706460	19207	12341499	SKID,SEAT BACK..... UOC:B16,H16	2
10	PAOZZ	5320010846101	11815	CR3212-6-3	RIVET,BLIND 3/16..... UOC:B16,H16	52

END OF FIGURE

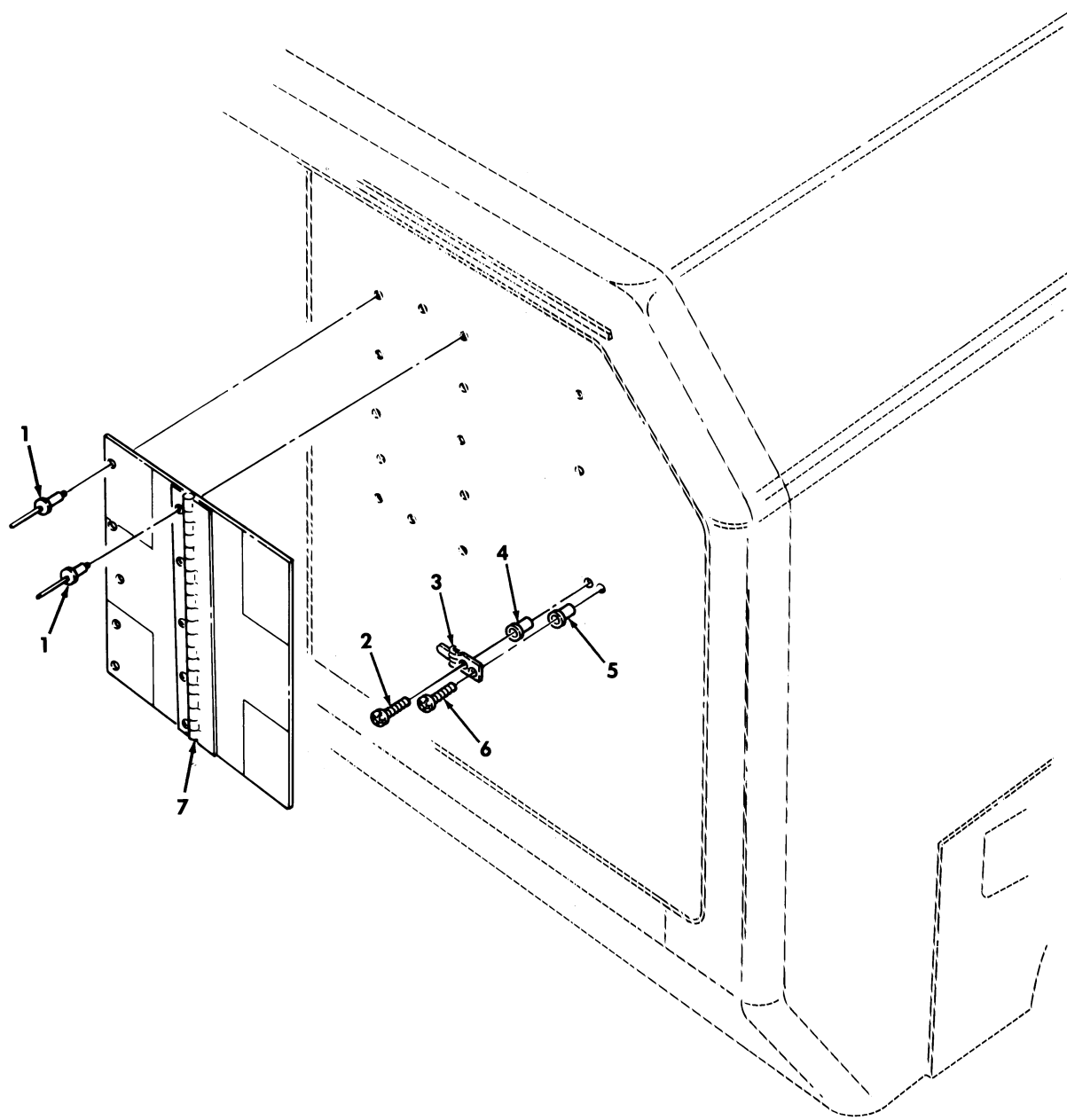
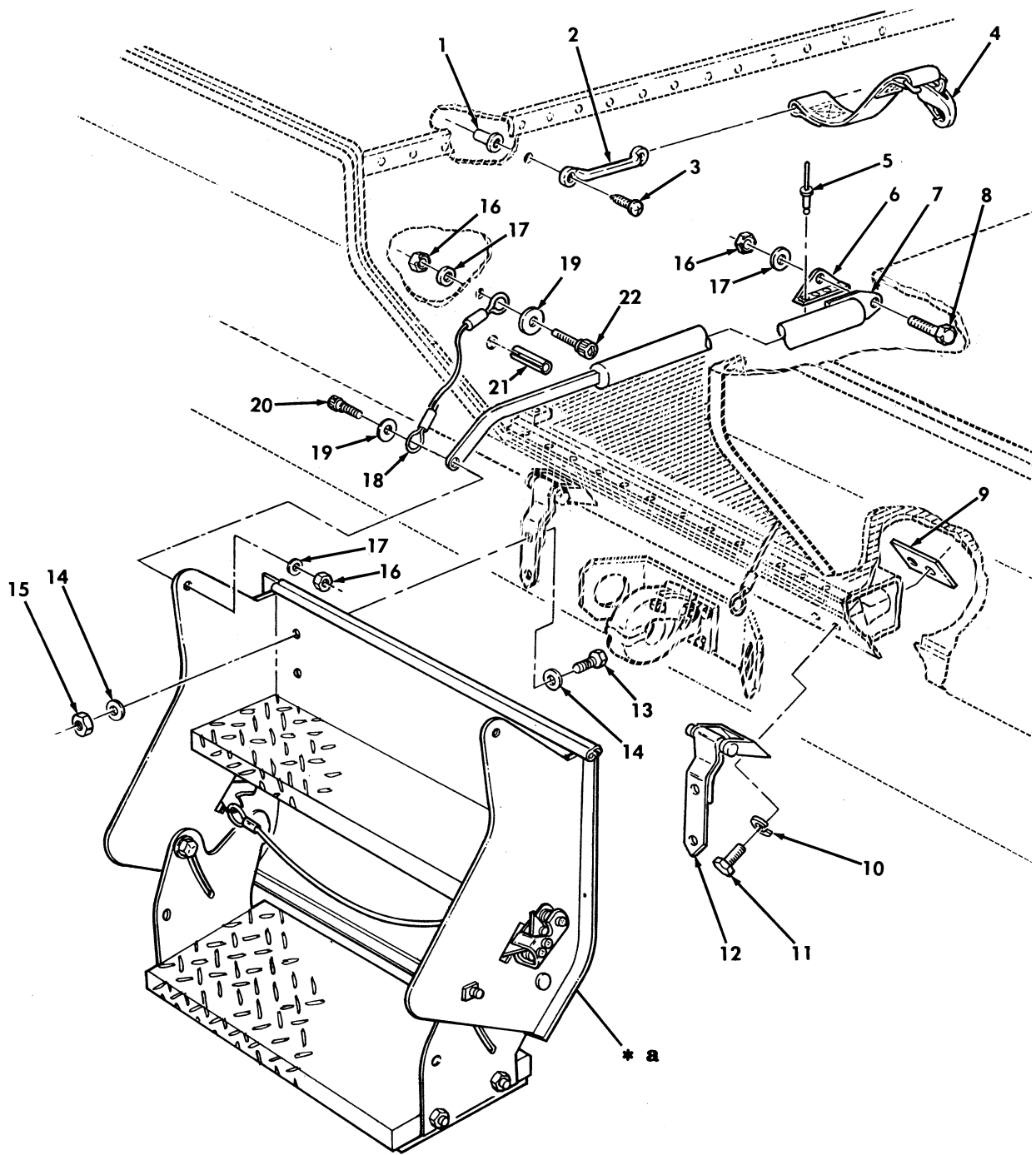

Figure 291. Red Cross Marking Rear Door, M996, M996A1, M997, M997A1, and M997A2 Ambulance.

SECTION II			TM9-2320-280-24P			
(1)	(2)	(3)	(4)	(5)	(6)	(7)
ITEM	SMR			PART		
NO	CODE	NSN	CAGEC	NUMBER	DESCRIPTION AND USABLE ON CODES(UC)	QTY
GROUP 1812 SPECIAL PURPOSE BODIES						
FIG. 291 RED CROSS MARKING REAR DOOR,M996,M996A1,M997,M997A1,AND M997A2 AMBULANCE						
1	PAOZZ	5320012716357	9K475	MGLP-B6-4	RIVET,BLIND.....	24
					UOC:A15,B15,H15	
1	PAOZZ	5320012716357	9K475	MGLP-B6-4	RIVET,BLIND.....	12
					UOC:B16,H16	
2	PAOZZ	5305009896265	96906	MS35207-262	SCREW,MACHINE #10-32 X 7/8.....	8
					UOC:A15,B15,H15	
2	PAOZZ	5305009896265	96906	MS35207-262	SCREW,MACHINE #10-32 X 7/8.....	4
					UOC:B16,H16	
3	PAOZZ	5340012715866	19207	12341798	CLIP,SPRING TENSION.....	8
					UOC:A15,B15,H15	
3	PAOZZ	5340012715866	19207	12341798	CLIP,SPRING TENSION.....	4
					UOC:B16,H16	
4	PAOZZ	5310010099785	96906	MS27130-20	NUT,PLAIN,BLIND RIV.....	8
					UOC:A15,B15,H15	
4	PAOZZ	5310010099785	96906	MS27130-20	NUT,PLAIN,BLIND RIV.....	4
					UOC:B16,H16	
5	PAOZZ	2510012653282	19207	12341082-2	PANEL,BODY,VEHICULA.....	2
					UOC:A15,B15,H15	
5	PAOZZ	2510012653282	19207	12341082-2	PANEL,BODY,VEHICULA.....	1
					UOC:B16,H16	
6	PAOZZ	5320011357319	80205	NAS9301BNS-6-03	RIVET,BLIND.....	10
					UOC:A15,B15,H15	
6	PAOZZ	5320011357319	80205	NAS9301BNS-6-03	RIVET,BLIND.....	5
					UOC:B16,H16	

END OF FIGURE



\* a FOR BREAKDOWN SEE FIGURE 293

Figure 292. Rear Step Mounting Hardware, M996, M996A1, M997, M997A1, and M997A2 Ambulance.

SECTION II			TM9-2320-280-24P			
(1)	(2)	(3)	(4)	(5)	(6)	(7)
ITEM NO	SMR CODE	NSN	CAGEC	PART NUMBER	DESCRIPTION AND USABLE ON CODES(UOC)	QTY
GROUP 1812 SPECIAL PURPOSE BODIES						
FIG. 292 REAR STEP MOUNTING HARDWARE ,M996,M996A1,M997,M997A1,AND M997A2 AMBULANCE						
1	PAOZZ	5310000742351	96906	MS27130-29	NUT,PLAIN,BLIND RIV #10-32 X 7/8... UOC:A15,B15,B16,H15,H16	2
2	PAOZZ	5340013145957	19207	12338839-1	LOOP,STRAP FASTENER..... UOC:A15,B15,B16,H15,H16	1
3	PAOZZ	5305001804966	96906	MS51849-64	SCREW,MACHINE..... UOC:A15,B15,B16,H15,H16	2
4	PAOZZ	5340013866067	19207	12341382	STRAP,WEBBING..... UOC:A15,B15,B16,H15,H16	1
5	PAOZZ	5320011357319	11815	CR-213-6-3	RIVET,BLIND 3/16..... UOC:A15,B15,B16,H15,H16	4
6	PFOZZ	5340012882127	34623	5598052	BRACKET,ANGLE..... UOC:A15,B15,B16,H15,H16	1
7	PAOZZ	2540012653160	19207	12341176	STEPPED,RETRACTABLE..... UOC:A15,B15,B16,H15,H16	1
8	PAOZZ	5305009890830	72582	186678	SCREW,CAP,HEXAGON H 3/8-16 X 1.00.. UOC:A15,B15,B16,H15,H16	1
9	PAOZZ	5310012724823	34623	5933974	NUT STRIP..... UOC:A15,B15,B16,H15,H16	2
10	PAOZZ	5310008094058	96906	MS27183-10	WASHER,FLAT 1/4..... UOC:A15,B15,B16,H15,H16	4
11	PAOZZ	5305002253843	80204	B1821BH025C100N	SCREW,CAP,HEXAGON H 1/4-20 X 1.00.. UOC:A15,B15,B16,H15,H16	4
12	PAOZZ	5340012658859	27182	J8UBXXFXBZ01	HINGE,TEE..... UOC:A15,B15,B16,H15,H16	2
13	PAOZZ	5306002264828	80204	B1821BH031C113N	BOLT,MACHINE 5/16-18 X 1.125..... UOC:A15,B15,B16,H15,H16	4
14	PAOZZ	5310012520512	34623	5592832	WASHER,FLAT 5/16..... UOC:A15,B15,B16,H15,H16	8
15	PAOZZ	5310008140673	96906	MS51943-33	NUT,SELF-LOCKING,HE 5/16-18..... UOC:A15,B15,B16,H15,H16	4
16	PAOZZ	5310009359021	96906	MS51943-35	NUT,SELF-LOCKING,HE 3/8-16..... UOC:A15,B15,B16,H15,H16	2
17	PAOZZ	5310000877493	96906	MS27183-13	WASHER,FLAT 3/8..... UOC:A15,B15,B16,H15,H16	5
18	PAOZZ	4010012663842	34623	5934065	WIRE ROPE ASSEMBLY,..... UOC:A15,B15,B16,H15,H16	2
19	PAOZZ	5310008095997	96906	MS27183-17	WASHER,FLAT 1/2..... UOC:A15,B15,B16,H15,H16	4
20	PAOZZ	5305012728323	19207	12341791-2	SCREW,SHOULDER 3/8-16 X 5/8..... UOC:A15,B15,B16,H15,H16	1
21	PAOZZ	5315012782123	96906	MS51987-117	PIN,SPRING 3/16 X 1.25..... UOC:A15,B15,B16,H15,H16	2
22	PAOZZ	5305012728322	19207	12341791-1	SCREW,SHOULDER 3/8-16 X 5/8..... UOC:A15,B15,B16,H15,H16	3

END OF FIGURE

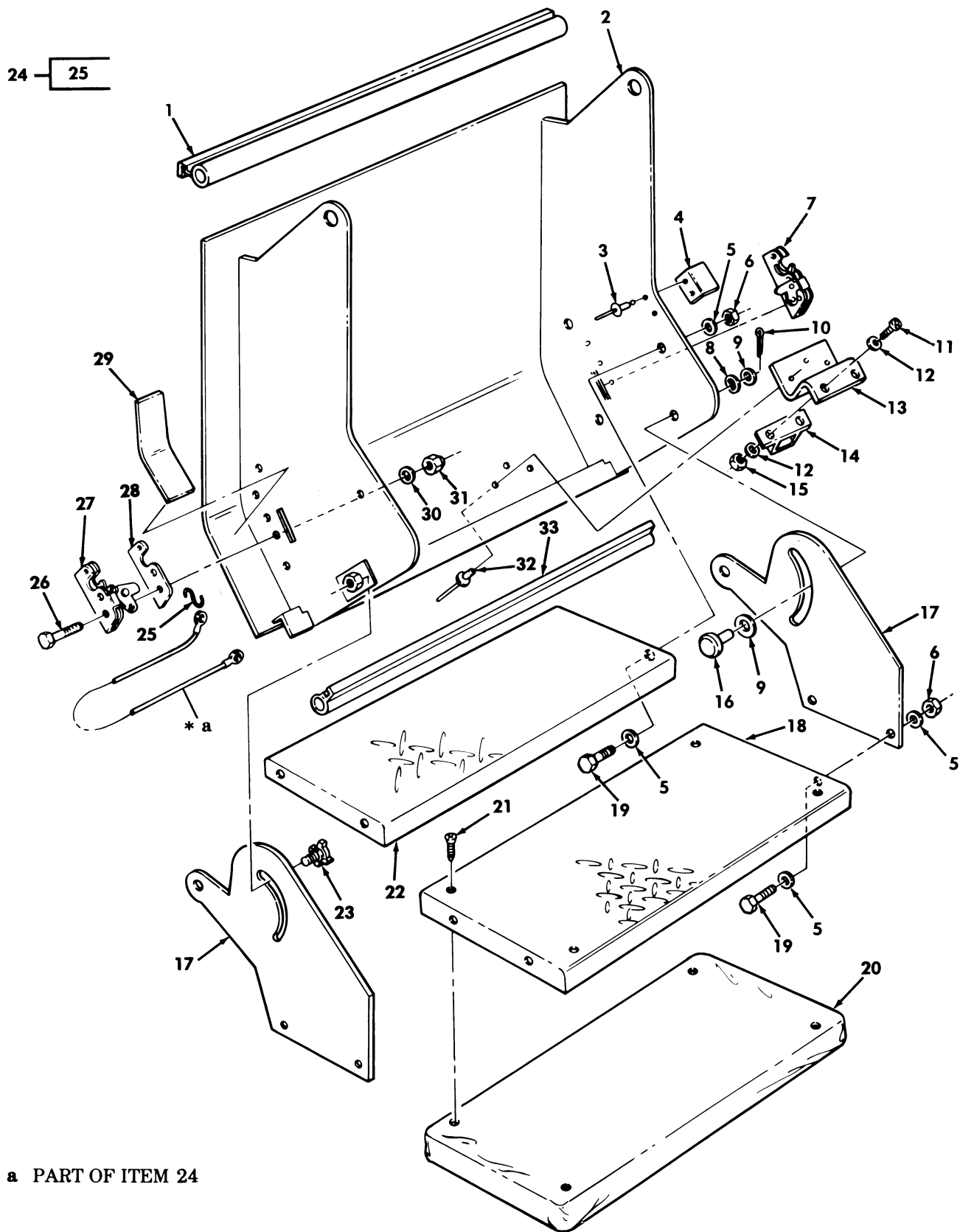

Figure 293. Rear Step Assembly, M996, M996A1, M997, M997A1, and M997A2 Ambulance.



SECTION II			TM9-2320-280-24P			
(1)	(2)	(3)	(4)	(5)	(6)	(7)
ITEM	SMR			PART		
NO	CODE	NSN	CAGEC	NUMBER	DESCRIPTION AND USABLE ON CODES(UC)	QTY
GROUP 1812 SPECIAL PURPOSE BODIES						
FIG. 293 REAR STEP ASSEMBLY, M996, M996A1, M997, M997A1, AND M997A2 AMBULANCE						
1	PAOZZ	5330012658803	19207	12341211-1	SEAL, PLAIN.....	1
					UOC:A15, B15, B16, H15, H16	
2	PFOZZ	2510012804240	19207	12341250	FRAME, STRUCTURAL, VE.....	1
					UOC:A15, B15, B16, H15, H16	
3	PAOZZ	5320012716357	9K475	MGLP-B6-4	RIVET, BLIND.....	2
					UOC:A15, B15, B16, H15, H16	
4	PAOZZ	5340012728397	19207	12342003	BRACKET, MOUNTING.....	2
					UOC:A15, B15, B16, H15, H16	
5	PAOZZ	5310000877493	96906	MS27183-13	WASHER, FLAT 3/8.....	16
					UOC:A15, B15, B16, H15, H16	
6	PAOZZ	5310009359021	96906	MS51943-35	NUT, SELF-LOCKING, HE 3/8-16.....	8
					UOC:A15, B15, B16, H15, H16	
7	PFOZZ	2540014251617	34623	5598864	LATCH, DOOR, VEHICULA R. H.....	1
					UOC:A15, B15, B16, H15, H16	
8	PAOZZ	5310011059398	92830	U500-0113	WASHER, SPRING TENSIS 1/2.....	3
					UOC:A15, B15, B16, H15, H16	
9	PAOZZ	5310008095998	96906	MS27183-18	WASHER, FLAT 1/2.....	7
					UOC:A15, B15, B16, H15, H16	
10	PAOZZ	5315008395820	80205	MS24665-134	PIN, COTTER 1/8 X 1.00.....	3
					UOC:A15, B15, B16, H15, H16	
11	PAOZZ	5305009846212	96906	MS35206-265	SCREW, MACHINE .190-24 X 3/4.....	4
					UOC:A15, B15, B16, H15, H16	
12	PAOZZ	5310000145850	96906	MS27183-42	WASHER, FLAT 3/16.....	8
					UOC:A15, B15, B16, H15, H16	
13	PFOZZ	5340012743295	19207	12341276	BRACKET, DOUBLE ANGL.....	2
					UOC:A15, B15, B16, H15, H16	
14	PAOZZ	5340012663845	34623	5588959	STRIKE, CATCH.....	2
					UOC:A15, B15, B16, H15, H16	
15	PAOZZ	5310009349764	96906	MS35649-205	NUT, PLAIN, HEXAGON .190-24.....	4
					UOC:A15, B15, B16, H15, H16	
16	PAOZZ	5315001401938	96906	MS35810-6	PIN, STRAIGHT, HEADED 1/2.....	3
					UOC:A15, B15, B16, H15, H16	
17	PFOZZ	2510012653155	19207	12341073	FRAME SECTION, STRUC.....	2
					UOC:A15, B15, H15	
17	PFOZZ	2510012653157	34623	5597895	SIDE PLATE, STEP.....	2
					UOC:B16, H16	
18	PFOZZ	2540012804159	34623	5589776	STEP, VEHICLE BOARDI.....	1
					UOC:A15, B15, B16, H15, H16	
19	PAOZZ	5305009890830	72582	186678	SCREW, CAP, HEXAGON H 3/8-16 X 1.00..	4
					UOC:A15, B15, B16, H15, H16	
20	PAOZZ	2540012711991	34623	12341168	CUSHION, SEAT, VEHICU.....	1
					UOC:A15, B15, B16, H15, H16	
21	PAOZZ	5305012837776	34623	5593432	SCREW, TAPPING #10-16 X .75.....	4
					UOC:A15, B15, B16, H15, H16	
22	PFOZZ	2510012653194	34623	12341092-1	STEP ASSEMBLY, UPPER.....	1
					UOC:A15, B15, B16, H15, H16	
23	PAOZZ		19207	12460217	KNOB.....	1

SECTION II			TM9-2320-280-24P			
(1)	(2)	(3)	(4)	(5)	(6)	(7)
ITEM	SMR			PART		
NO	CODE	NSN	CAGEC	NUMBER	DESCRIPTION AND USABLE ON CODES(UOC)	QTY
24	PAOZZ	4010012997699	34623	12342007	UOC:A15,B15,B16,H15,H16 WIRE ROPE ASSEMBLY,.....	1
25	PAOZZ	4030009487315	96906	MS87006-33	UOC:A15,B15,B16,H15,H16 .HOOK,CHAIN,S.....	4
26	PAOZZ	5305000712512	80204	B1821BH025C225N	UOC:A15,B15,B16,H15,H16 SCREW,CAP,HEXAGON H 1/4-20 X 2.25..	6
27	PFOZZ	5342012651129	27182	S450XXLXBZXX	UOC:A15,B15,B16,H15,H16 LATCH ASSEMBLY,STEP L.H.....	1
28	PFOZZ	5365012987780	19207	12342002	UOC:A15,B15,B16,H15,H16 SPACER,PLATE.....	2
29	PAOZZ	5330012810911	34623	5597687	UOC:A15,B15,B16,H15,H16 GASKET.....	2
30	PAOZZ	5310008094058	96906	MS27183-10	UOC:A15,B15,B16,H15,H16 WASHER,FLAT 1/4.....	6
31	PAOZZ	5310000614650	96906	MS51943-31	UOC:A15,B15,B16,H15,H16 NUT,SELF-LOCKING,HE 1/4-20.....	6
32	PAOZZ	5320010859995	80205	NAS9301BNS-6-07	UOC:A15,B15,B16,H15,H16 RIVET,BLIND 3/16.....	6
33	PFOZZ	5330012659231	19207	12341211-4	UOC:A15,B15,B16,H15,H16 SEAL,PLAIN.....	1
34	PAOZZ	5315012067135	92871	G121224	UOC:A15,B15,B16,H15,H16 PIN,COTTER.....	1

END OF FIGURE

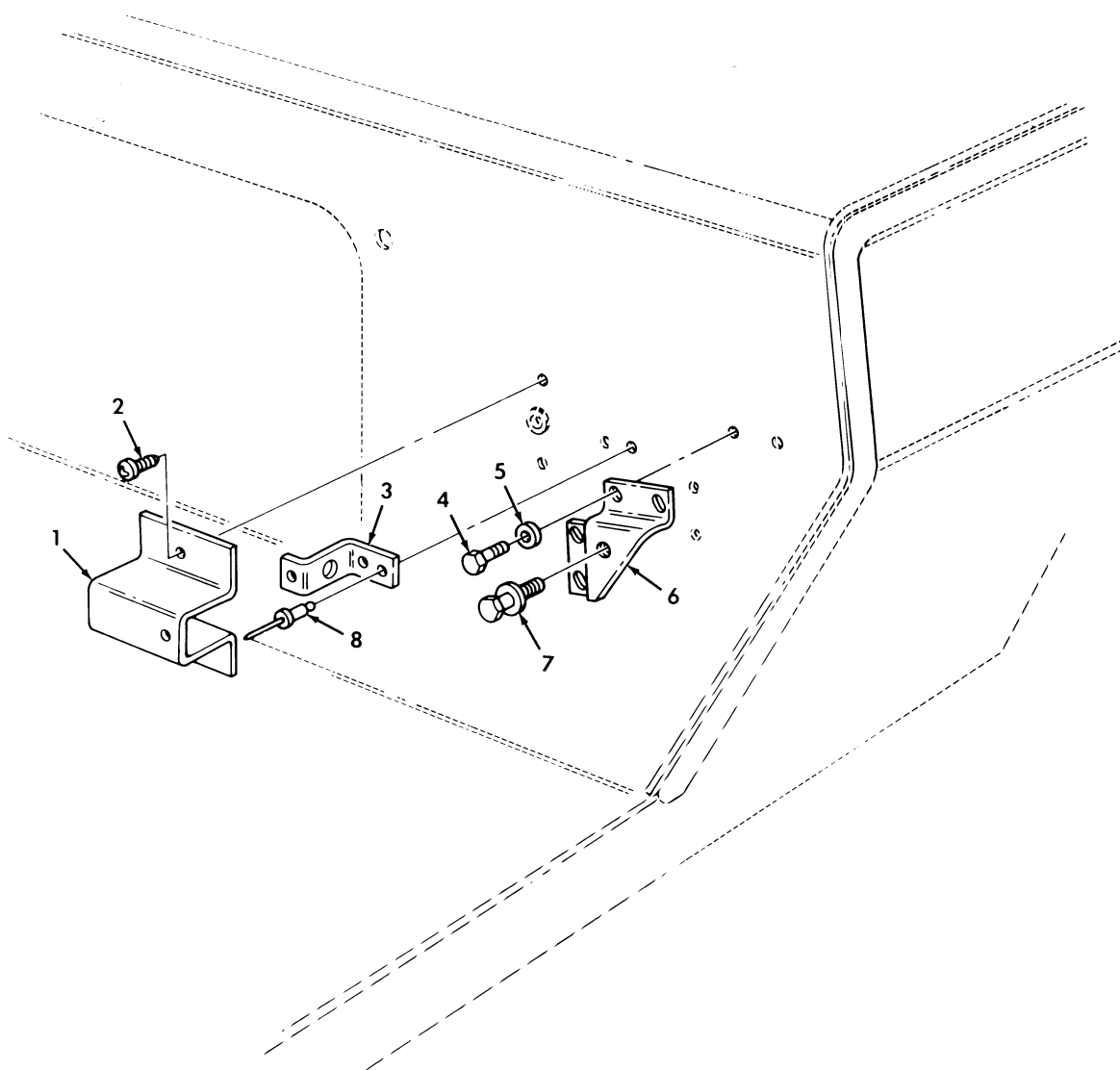

Figure 294. Rear Step Latch, Bracket, and Blackout Switch Mounting Hardware, M996, M996A1, M997, M997A1, and M997A2 Ambulance.

SECTION II			TM9-2320-280-24P			
(1)	(2)	(3)	(4)	(5)	(6)	(7)
ITEM	SMR			PART		
NO	CODE	NSN	CAGEC	NUMBER	DESCRIPTION AND USABLE ON CODES(UC)	QTY
GROUP 1812 SPECIAL PURPOSE BODIES						
FIG. 294 REAR STEP LATCH, STRIKER BRACKET, AND BLACKOUT SWITCH MOUNTING HARDWARE, M996, M996A1, M997, M997A1, AND M997A2 AMBULANCE						
1	PFOZZ	5975012708552	19207	12341003	COVER, JUNCTION BOX REAR DOOR.....	1
					UOC:A15, B15, B16, H15, H16	
2	PAOZZ	5305008550957	80205	MS24629-46	SCREW, TAPPING #10-24 X .50.....	3
					UOC:A15, B15, B16, H15, H16	
3	PFOZZ	5340012729109	19207	12341004	BRACKET, DOUBLE ANGL.....	1
					UOC:A15, B15, B16, H15, H16	
4	PAOZZ	5305000680502	96906	MS90725-6	SCREW, CAP, HEXAGON H 1/4-20 X .75...	8
					UOC:A15, B15, B16, H15, H16	
5	PAOZZ	5310008094058	96906	MS27183-10	WASHER, FLAT 1/4.....	8
					UOC:A15, B15, B16, H15, H16	
6	PFOZZ	5340012962814	34623	12342005	BRACKET, MOUNTING.....	2
					UOC:A15, B15, B16, H15, H16	
7	PAOZZ	5306012658897	27182	J4501XXBZ01	BOLT, SHOULDER.....	2
					UOC:A15, B15, B16, H15, H16	
8	PAOZZ	5320012734601	11815	CR-213-6-8	RIVET, BLIND 3/16.....	2
					UOC:A15, B15, B16, H15, H16	

END OF FIGURE

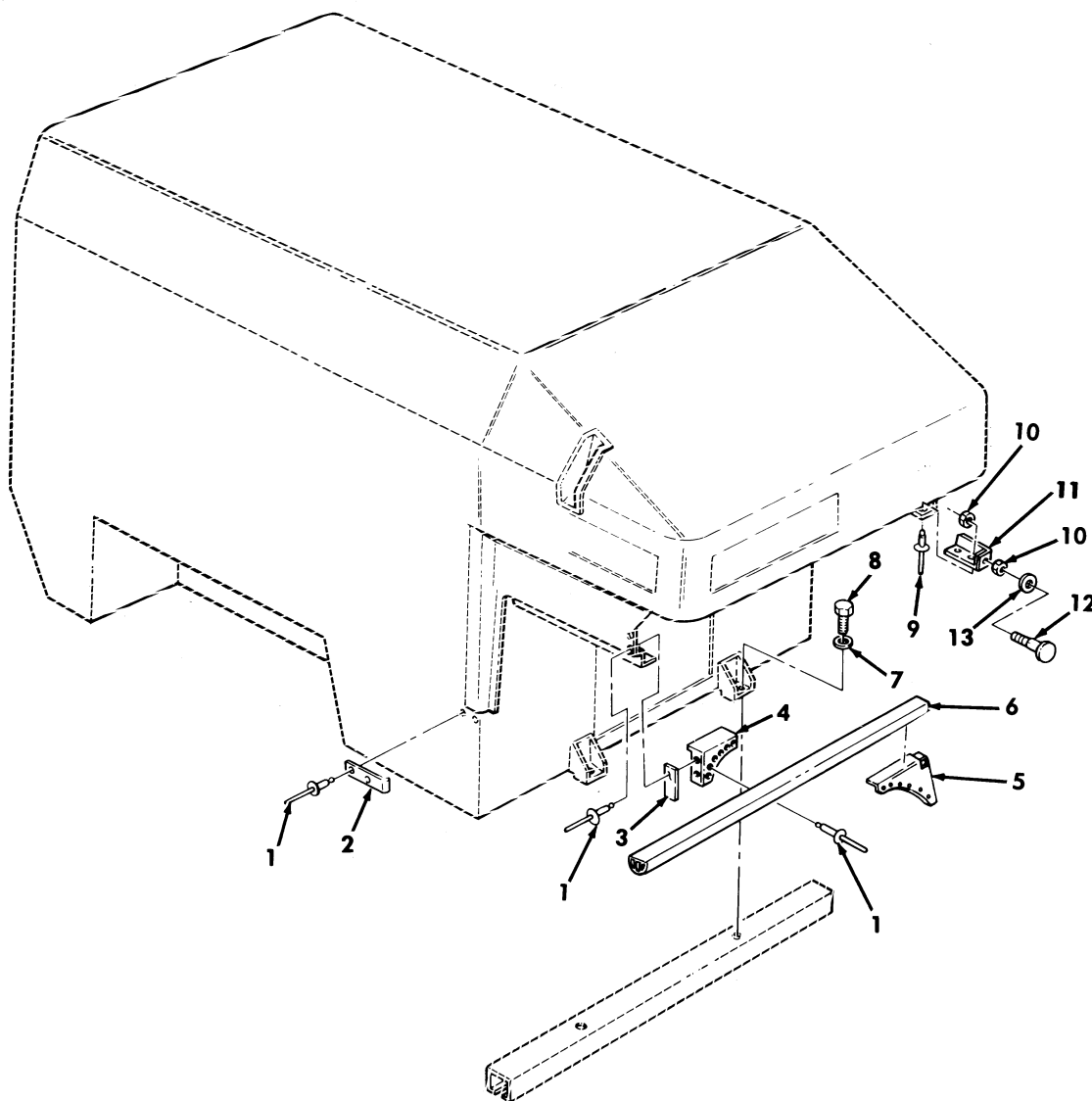

Figure 295. Two and Four Liter Ambulance Body, Mounting Hardware and Seals, M996, M996A1, M997, M997A1, and M997A2 Ambulance.

SECTION II			TM9-2320-280-24P			
(1)	(2)	(3)	(4)	(5)	(6)	(7)
ITEM	SMR			PART		
NO	CODE	NSN	CAGEC	NUMBER	DESCRIPTION AND USABLE ON CODES(UOC)	QTY
GROUP 1812 SPECIAL PURPOSE BODIES						
FIG. 295 TWO AND FOUR LITTER AMBULANCE BODY MOUNTING HARDWARE AND SEALS, M996, M996A1, M997, M997A1, AND M997A2 AMBULANCE						
1	PAFZZ	5320012716357	9K475	MGLP-B6-4	RIVET, BLIND WHEELHOUSE SEAL, 3/16...	14
					UOC: A15, B15, B16, H15, H16	
2	PAHZZ	5340012902265	34623	5598163	BRACKET, ANGLE.....	2
					UOC: A15, B15, B16, H15, H16	
3	PAFZZ	5330012727473	34623	5589947	GASKET.....	2
					UOC: A15, B15, B16, H15, H16	
4	PAFZZ	2510012709447	34623	5585446	EXTENSION, WINDSHIEL R.H.....	1
					UOC: A15, B15, B16, H15, H16	
5	PAFZZ	2590012709446	34623	5585445	BRACKET, VEHICULAR C L.H.....	1
					UOC: A15, B15, B16, H15, H16	
6	PAFZZ	5330011978298	06968	ORD-112	SEAL.....	1
					UOC: A15, B15, B16, H15, H16	
7	PAFZZ	5310008095998	96906	MS27183-18	WASHER, FLAT 1/2.....	2
					UOC: A15, B15, B16, H15, H16	
8	PAFZZ	5305000712071	80204	B1821BH050C200N	SCREW, CAP, HEXAGON H 1/2-13 X 2.00..	2
					UOC: A15, B15, B16, H15, H16	
9	PAOZZ	5320012645978	19207	12339355-2	RIVET, BLIND 3/16.....	42
					UOC: A15, B15, B16, H15, H16	
10	PAOZZ	5310008807744	96906	MS51967-5	NUT, PLAIN, HEXAGON 5/16-18.....	4
					UOC: A15, B15, B16, H15, H16	
11	PAOZZ	5340012893245	34623	5598904	BRACKET, MOUNTING.....	2
					UOC: A15, B15, B16, H15, H16	
12	PAOZZ	5342012897708	70655	4375	BUMPER, SPECIAL.....	2
					UOC: A15, B15, B16, H15, H16	
13	PAOZZ	5310008095998	96906	MS27183-18	WASHER, FLAT 5/16.....	2
					UOC: A15, B15, B16, H15, H16	

END OF FIGURE

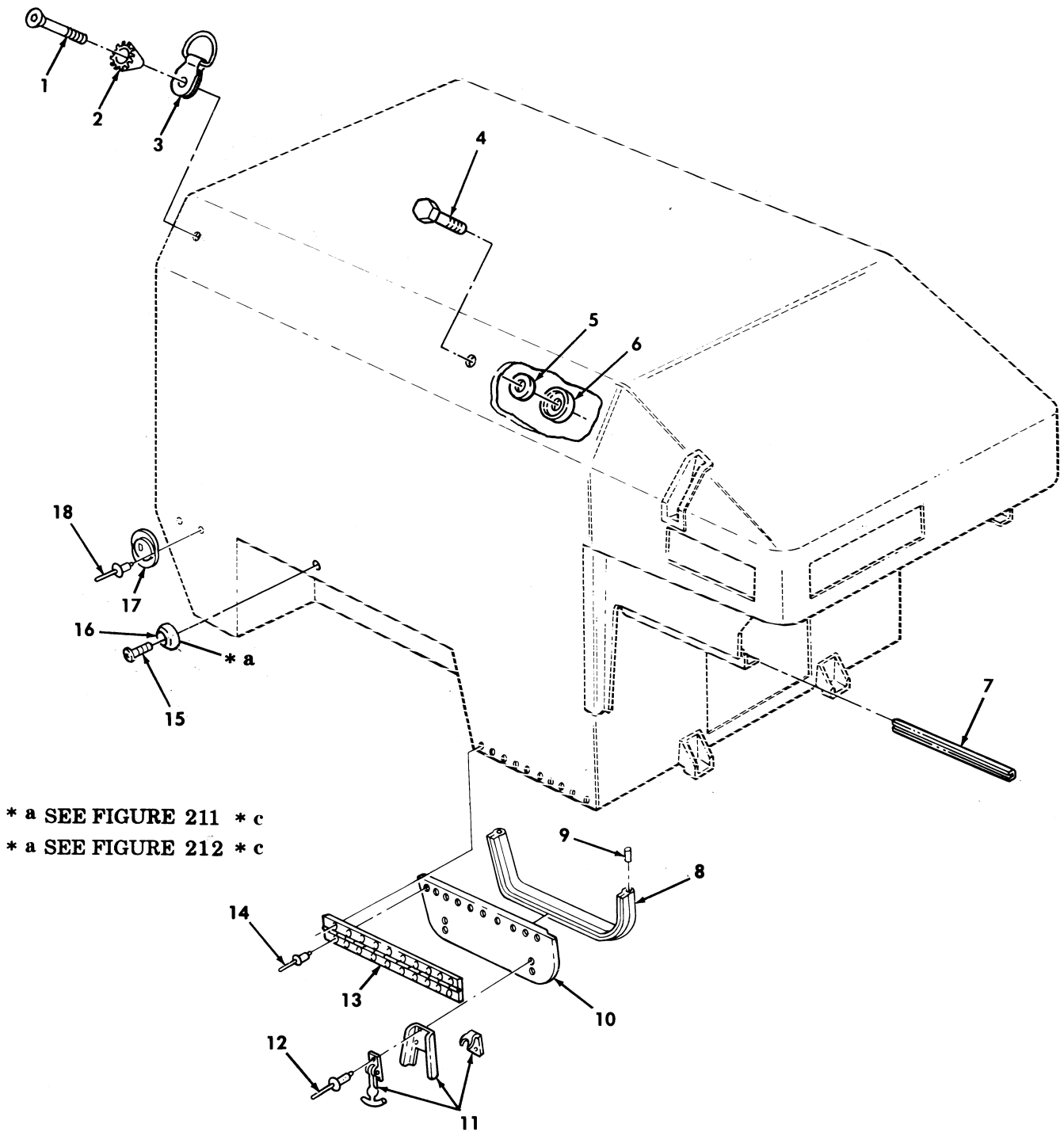

Figure 296. Two and Four Liter Ambulance Body Mounting Hardware and Seals, M996, M996A1, M997, M997A1, and M997A2 Ambulance.

SECTION II			TM9-2320-280-24P			
(1)	(2)	(3)	(4)	(5)	(6)	(7)
ITEM NO	SMR CODE	NSN	CAGEC	PART NUMBER	DESCRIPTION AND USABLE ON CODES(UOC)	QTY
GROUP 1812 SPECIAL PURPOSE BODIES						
FIG. 296 TWO AND FOUR LITTER AMBULANCE BODY MOUNTING HARDWARE AND SEALS, M996, M996A1, M997, M997A1, AND M997A2 AMBULANCE						
1	PAOZZ	5305000522232	96906	MS24667-77	SCREW, CAP, SOCKET HE..... UOC:A15, B15, B16, H15, H16	4
2	PAOZZ	5310009572677	96906	MS35336-53	WASHER, LOCK..... UOC:A15, B15, B16, H15, H16	4
3	PAOZZ	3990013148393	19207	12342077	TIE DOWN, CARGO, VEHI..... UOC:A15, B15, B16, H15, H16	4
4	PAOZZ	5305000712066	80204	B1821BH050C100N	SCREW, CAP, HEXAGON H..... UOC:A15, B15, B16, H15, H16	4
5	PAOZZ	5330012746106	19207	12341700	GASKET..... UOC:A15, B15, B16, H15, H16	2
6	PAOZZ	5340012144992	19207	12339545	RETAINER, HELICAL CO..... UOC:A15, B15, B16, H15, H16	4
7	PAOZZ	9390012829949	76385	ZX-4597	NONMETALLIC CHANNEL..... UOC:A15, B15, B16, H15, H16	2
8	PAOZZ	5330012753381	76385	ZX-2024	SEAL, NONMETALLIC SP..... UOC:A15, B15, B16, H15, H16	2
9	PAOZZ	5330012986009	19207	12340926-3	RUBBER ROUND SECTIO..... UOC:A15, B15, B16, H15, H16	8
10	PAOZZ	2510012707925	34623	5588931	DOOR, HATCH, VEHICLE STOWAGE, L.H..... UOC:A15, B15, B16, H15, H16	1
10	PAOZZ	2510012706487	34623	5588932	DOOR, HATCH, VEHICLE STOWAGE, R.H..... UOC:A15, B15, B16, H15, H16	1
11	PAOZZ	5340012716461	27182	F35SRBXXBZXX	CATCH, CLAMPING..... UOC:A15, B15, B16, H15, H16	4
12	PAOZZ	5320000835009	11078	ADS43	RIVET, BLIND 1/8..... UOC:A15, B15, B16, H15, H16	16
13	PFOZZ	5340012971549	34623	5592234	HINGE, BUTT..... UOC:A15, B15, B16, H15, H16	2
14	PAOZZ	5320012716357	9K475	MGLP-B6-4	RIVET, BLIND 3/16..... UOC:A15, B15, B16, H15, H16	40
15	PAOZZ	5305000711318	96906	MS51957-83	SCREW, MACHINE..... UOC:A15, B15, B16, H15, H16	2
16	PAOZZ	5340013097900	34623	5589853-A	HOLDER, DOOR..... UOC:A15, B15, B16, H15, H16	2
17	PAOZZ	9905002052795	96906	MS35387-1	REFLECTOR, INDICATIN..... UOC:A15, B15, B16, H15, H16	2
18	PAOZZ	5320012711834	34623	5575940	RIVET, SOLID 3/16..... UOC:A15, B15, B16, H15, H16	4

END OF FIGURE



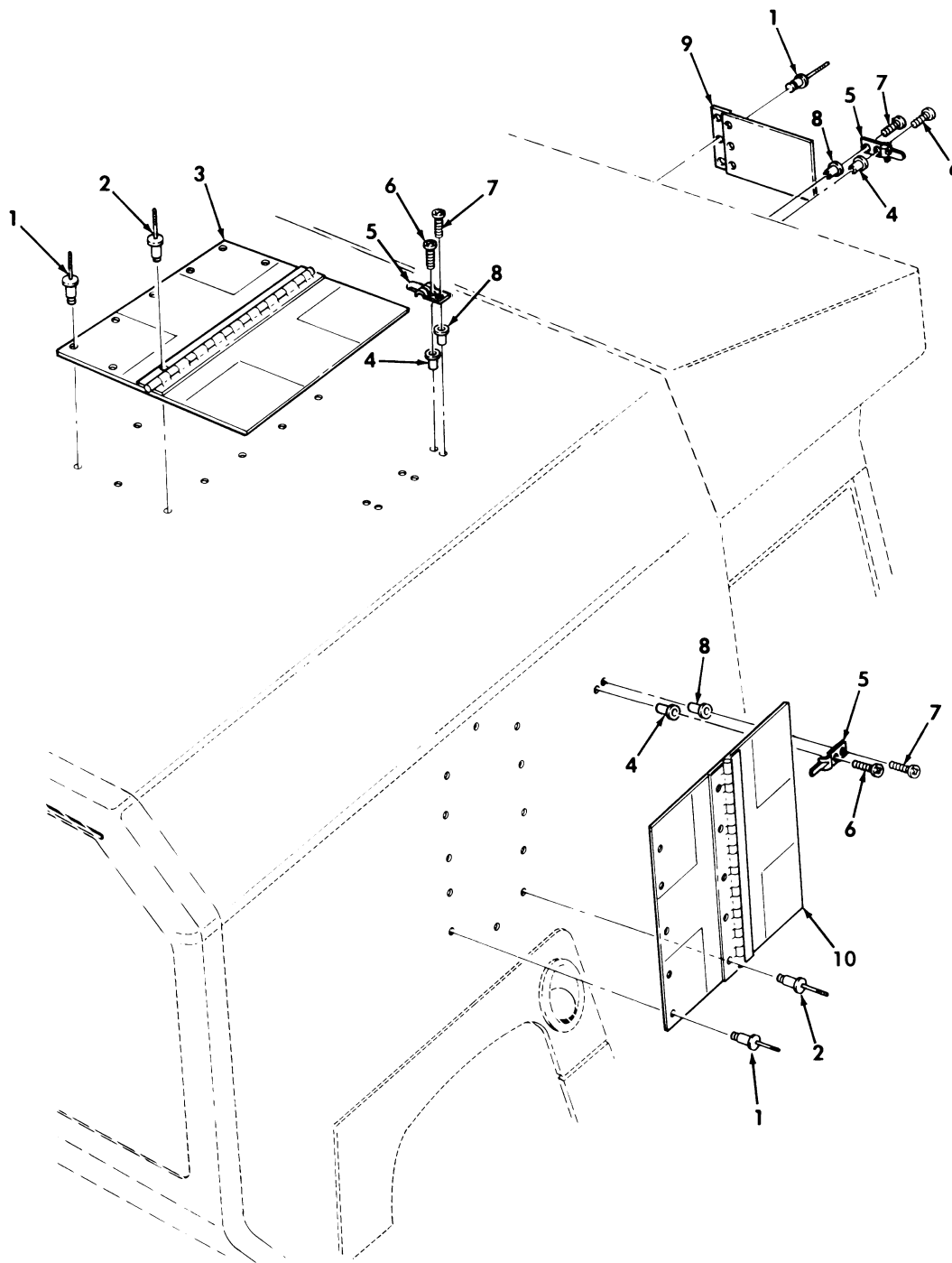

Figure 297. Two and Four Litter Ambulance Body , Red Cross Markings, M996, M996A1, M997, M997A1, and M997A2 Ambulance.

SECTION II			TM9-2320-280-24P			
(1)	(2)	(3)	(4)	(5)	(6)	(7)
ITEM	SMR			PART		
NO	CODE	NSN	CAGEC	NUMBER	DESCRIPTION AND USABLE ON CODES(UOC)	QTY
GROUP 1812 SPECIAL PURPOSE BODIES						
FIG. 297 TWO AND FOUR LITTER						
AMBULANCE BODY,RED CROSS MARKINGS,						
M996,M996A1,M997,M997A1,AND M997A2						
AMBULANCE						
1	PAOZZ	5320012716357	9K475	MGLP-B6-4	RIVET,BLIND 3/16.....	21
					UOC:A15,B15,H15	
1	PAOZZ	5320012716357	9K475	MGLP-B6-4	RIVET,BLIND 3/16.....	25
					UOC:B16,H16	
2	PAOZZ	5320012645978	19207	12339355-2	RIVET,BLIND 3/16.....	6
					UOC:A15,B15,B16,H15,H16	
2	PAOZZ	5320012645978	19207	12339355-2	RIVET,BLIND.....	11
					UOC:B16,H16	
3	PAOZZ	2510012653281	19207	12341082-1	PANEL,BODY,VEHICULA.....	1
					UOC:A15,B15,B16,H15,H16	
4	PAOZZ	5310008110966	80205	NAS1329A3B80	NUT,PLAIN,BLIND RIV.....	22
					UOC:A15,B15,H15	
4	PAOZZ	5310008110966	80205	NAS1329A3B80	NUT,PLAIN,BLIND RIV.....	16
					UOC:B16,H16	
5	PAOZZ	5340012715866	19207	12341798	CLIP,SPRING TENSION.....	16
					UOC:B16,H16	
5	PAOZZ	5340012715866	19207	12341798	CLIP,SPRING TENSION.....	22
					UOC:A15,B15,H15	
6	PAOZZ	5305009953444	96906	MS35207-266	SCREW,MACHINE #10-32 X 7/8.....	16
					UOC:B16,H16	
6	PAOZZ	5305009953444	96906	MS35207-266	SCREW,MACHINE #10-32 X 7/8.....	22
					UOC:A15,B15,H15	
7	PAOZZ	5305009930190	96906	MS35206-214	SCREW,MACHINE.....	22
					UOC:A15,B15,H15	
7	PAOZZ	5305009930190	96906	MS35206-214	SCREW,MACHINE.....	16
					UOC:B16,H16	
8	PAOZZ		80205	NAS1329A4B60	NUT,PLAIN,BLIND RIV.....	22
					UOC:A15,B15,H15	
8	PAOZZ		80205	NAS1329A4B60	NUT,PLAIN,BLIND RIV.....	16
					UOC:B16,H16	
9	PAOZZ	2510012653283	19207	12341081-2	PANEL,BODY,VEHICULA.....	1
					UOC:A15,B15,H15	
10	PAOZZ	2510012653282	19207	12341082-2	PANEL,BODY,VEHICULA.....	2
					UOC:B16,H16	
10	PAOZZ	2510012653281	19207	12341082-1	PANEL,BODY,VEHICULA.....	2
					UOC:A15,B15,H15	

END OF FIGURE

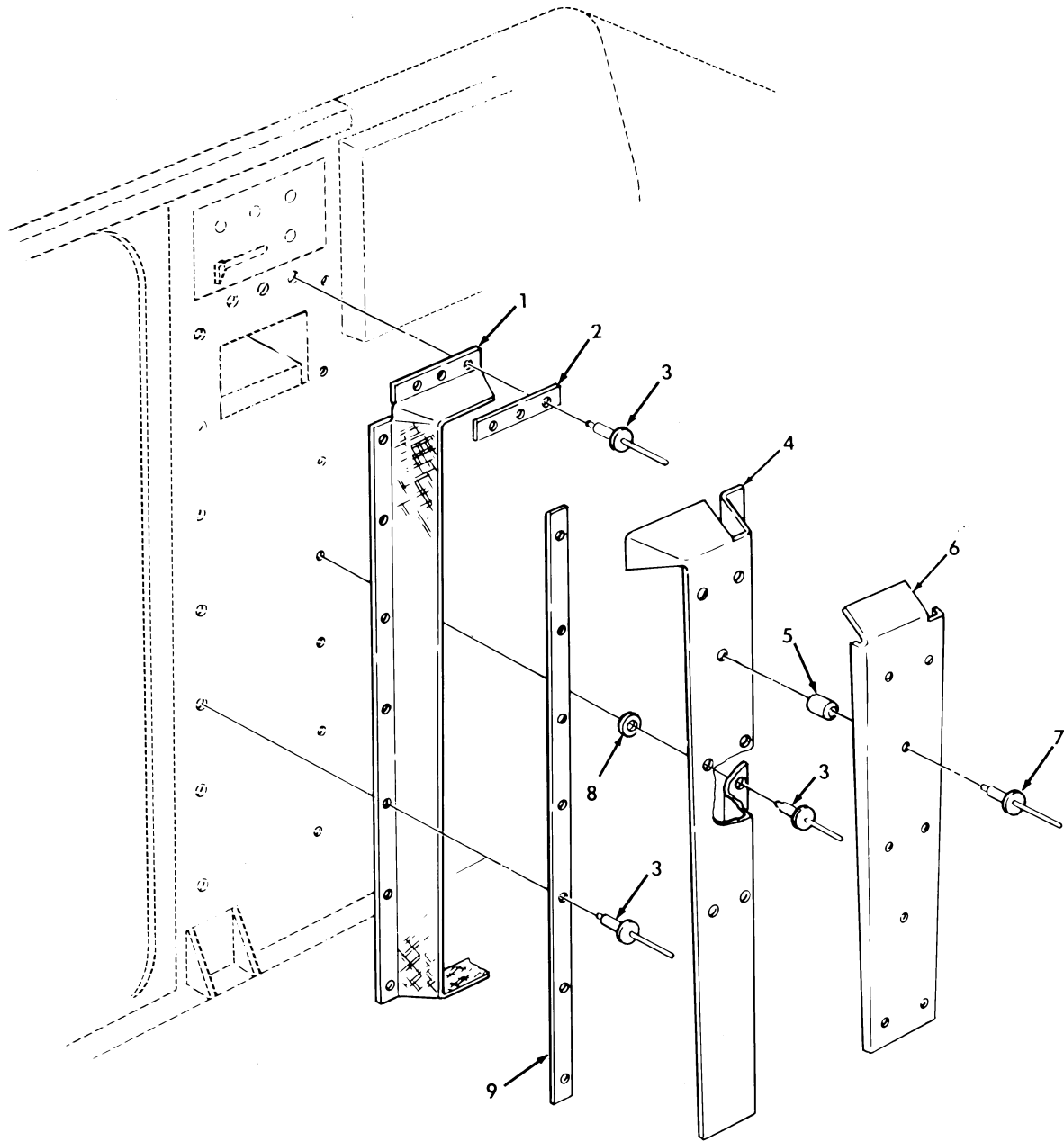

Figure 298. Heater Duct and Grille, M996 and M996A1 Ambulance.

SECTION II			TM9-2320-280-24P			
(1)	(2)	(3)	(4)	(5)	(6)	(7)
ITEM	SMR			PART		
NO	CODE	NSN	CAGEC	NUMBER	DESCRIPTION AND USABLE ON CODES(UC)	QTY
GROUP 1812 SPECIAL PURPOSE BODIES						
FIG. 298 HEATER DUCT AND GRILLE,M996 AND M996A1 AMBULANCE						
1	PAOZZ	5340012704415	19207	12341552	GRILLE,METAL.....	1
					UOC:B16,H16	
2	PAOZZ	5365012726574	34623	12341489-2	SPACER,PLATE.....	1
					UOC:B16,H16	
3	PAOZZ	5320012716357	9K475	MGLP-B6-4	RIVET,BLIND 3/16.....	17
					UOC:B16,H16	
4	PAOZZ	4520012705080	19207	12341551	PIPE,AIR CONDITIONI.....	1
					UOC:B16,H16	
5	PAOZZ	5365012728376	34623	5598113	SPACER,SLEEVE.....	8
					UOC:B16,H16	
6	PAOZZ	2540012704353	34623	5598104	SHIELD,HEATER DUCT.....	1
					UOC:B16,H16	
7	PAOZZ	5320012237728	11815	AAP-610	RIVET,BLIND 3/16.....	8
					UOC:B16,H16	
8	PAOZZ	5310012349416	96906	MS51412-2	WASHER,FLAT #10.....	7
					UOC:B16,H16	
9	PAOZZ	5365012730010	34623	5598107	SPACER,PLATE.....	1
					UOC:B16,H16	

END OF FIGURE

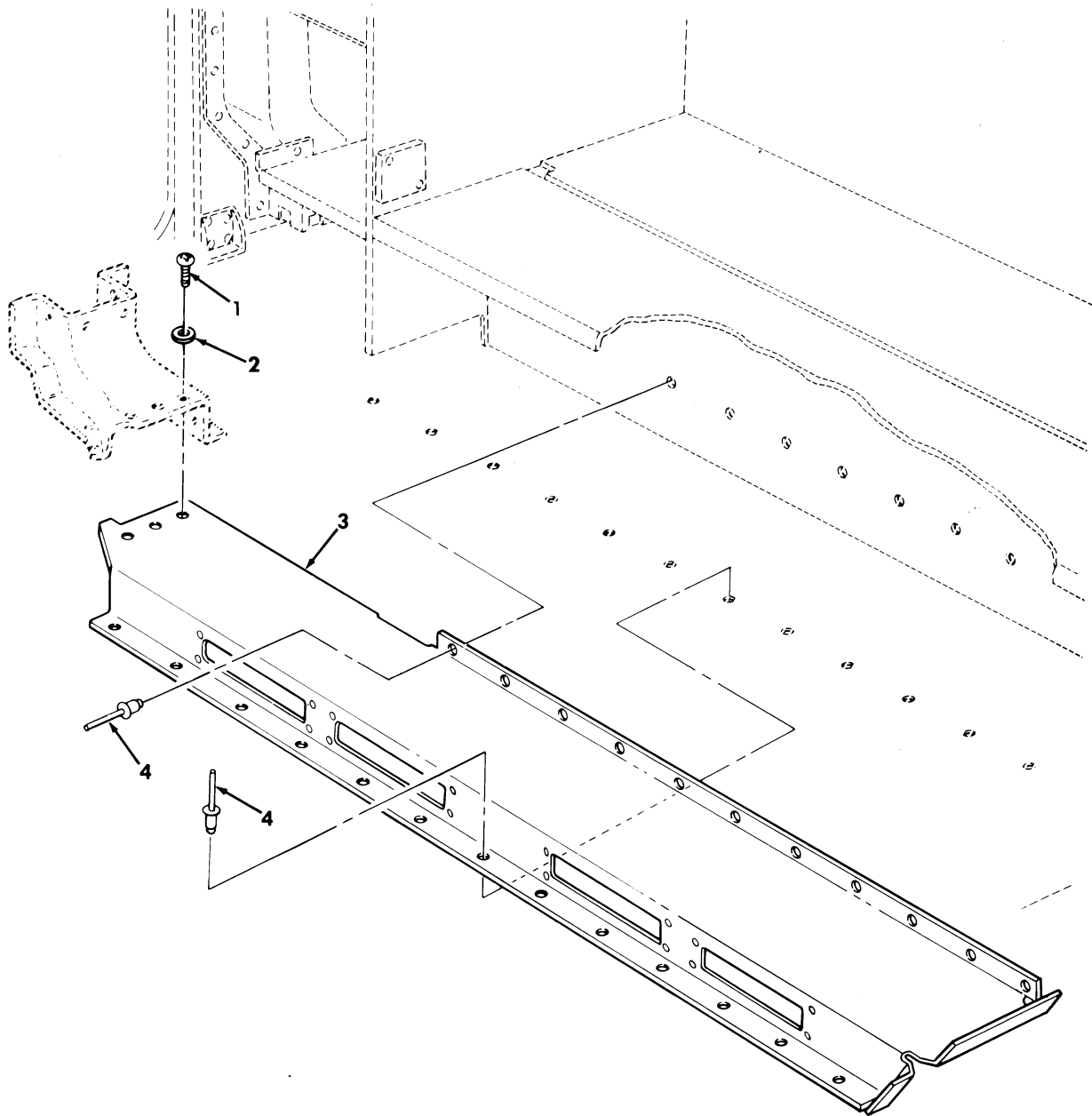

Figure 299. Heating Director Housing Assembly, M997, M997A1, and M997A2 Ambulance.

SECTION II			TM9-2320-280-24P			
(1)	(2)	(3)	(4)	(5)	(6)	(7)
ITEM	SMR			PART		
NO	CODE	NSN	CAGEC	NUMBER	DESCRIPTION AND USABLE ON CODES(UC)	QTY
					GROUP 1812 SPECIAL PURPOSE BODIES	
					FIG. 299 HEATING DIRECTOR HOUSING ASSEMBLY,M997,M997A1,AND M997A2 AMBULANCE	
1	PAOZZ	5305009846210	08484	WA-1429-10	SCREW,MACHINE #10-24 X 1/2.....	3
					UOC:A15,B15,H15	
2	PAOZZ	5310000145850	96906	MS27183-42	WASHER,FLAT #10.....	4
					UOC:A15,B15,H15	
3	PAOZZ	2540012687203	19207	12341139	HOUSING,HEATING DIR.....	1
					UOC:A15,B15,H15	
4	PAOZZ	5320012716357	9K475	MGLP-B6-4	RIVET,BLIND 3/16.....	24
					UOC:A15,B15,H15	

END OF FIGURE

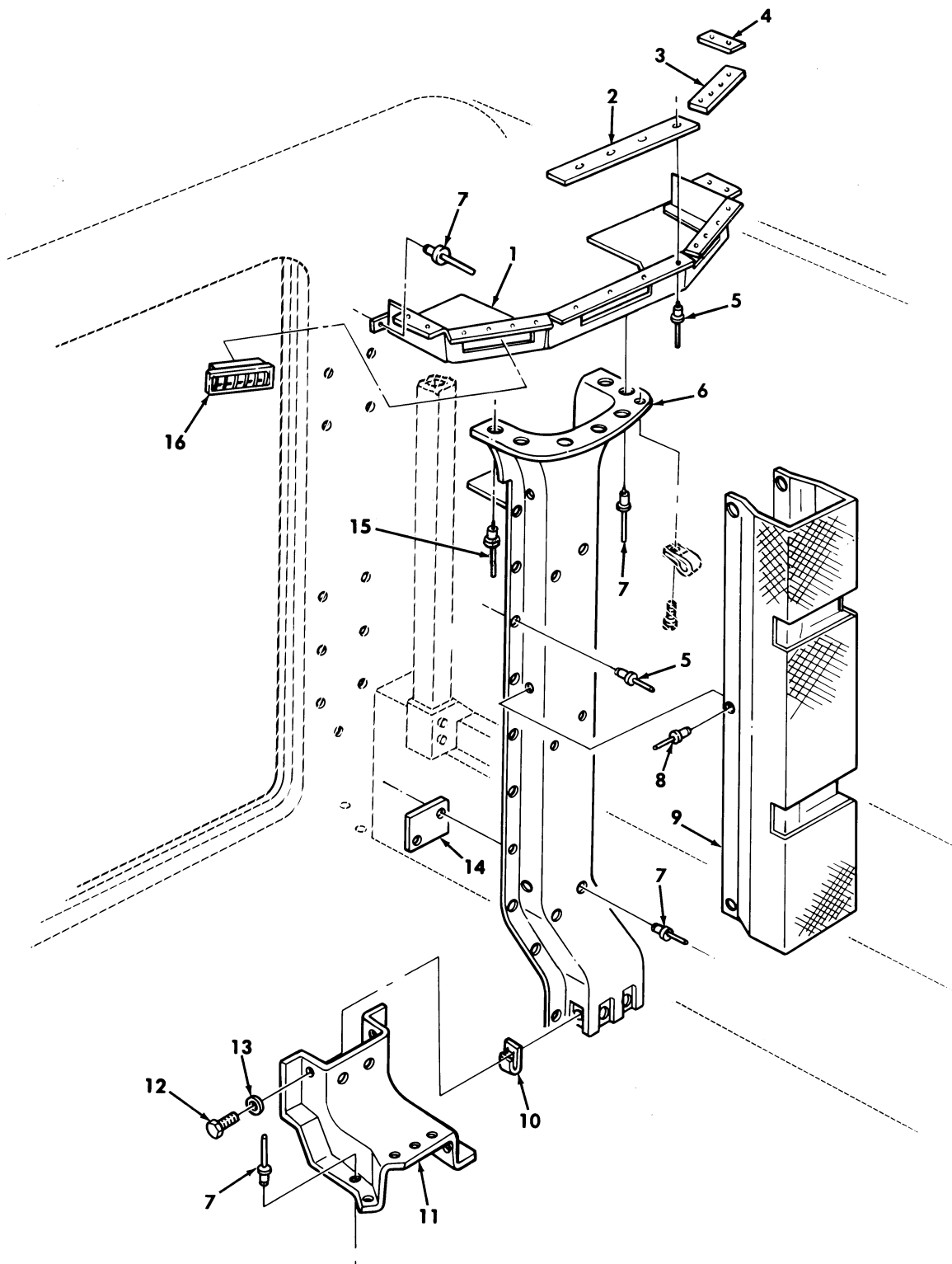

Figure 300. Patient Compartment Heater and A/C Ducts, M997, M997A1, and M997A2 Ambulance.

SECTION II			TM9-2320-280-24P			
(1)	(2)	(3)	(4)	(5)	(6)	(7)
ITEM	SMR			PART		
NO	CODE	NSN	CAGEC	NUMBER	DESCRIPTION AND USABLE ON CODES(UOC)	QTY
GROUP 1812 SPECIAL PURPOSE BODIES						
FIG. 300 PATIENT COMPARTMENT HEATER AND A/C DUCTS,M997,M997A1,AND M997A2 AMBULANCE						
1	PFOZZ	2510012709707	34623	5589763	PANEL,BODY,VEHICULA.....	1
					UOC:A15,B15,H15	
2	PAOZZ	5340012944415	19207	12342000-2	BRACKET,MOUNTING.....	1
					UOC:A15,B15,H15	
3	PAOZZ	5340012943230	19207	12342000-1	BRACKET,MOUNTING.....	2
					UOC:A15,B15,H15	
4	PAOZZ	5340013063606	19207	12342000-3	BRACKET,MOUNTING.....	2
					UOC:A15,B15,H15	
5	PAOZZ	5320012645978	19207	12339355-2	RIVET,BLIND 3/16.....	16
					UOC:A15,B15,H15	
6	PFOZZ	4720012716151	19207	12341591	HOSE,AIR DUCT.....	1
					UOC:A15,B15,H15	
7	PAOZZ	5320012716357	9K475	MGLP-B6-4	RIVET,BLIND 3/16.....	33
					UOC:A15,B15,H15	
8	PAOZZ	5320004934101	81349	M24243/1-B604	RIVET,BLIND 3/16.....	6
					UOC:A15,B15,H15	
9	PFOZZ	2540012713769	19207	12341535	SHIELD,HEATER DUCT.....	1
					UOC:A15,B15,H15	
10	PAOZZ	5310012725464	78553	C-8036-832	NUT,SHEET SPRING #8-32.....	4
					UOC:A15,B15,H15	
11	PFOZZ	4520012712949	19207	12341553	PIPE,AIR CONDITIONI.....	1
					UOC:A15,B15,H15	
12	PAOZZ	5305009846193	96906	MS35206-245	SCREW,MACHINE #8-32 X .50.....	4
					UOC:A15,B15,H15	
13	PAOZZ	5310012531618	96906	MS51412-18	WASHER,FLAT #8.....	4
					UOC:A15,B15,H15	
14	PFOZZ	5365012727482	19207	12340961	SPACER,PLATE.....	3
					UOC:A15,B15,H15	
15	PAOZZ	5320011435075	11815	CR3213-6-2	RIVET,BLIND 3/16.....	1
					UOC:A15,B15,H15	
16	PFOZZ	2540012828562	21102	HV032504	VENTILATOR,AIR CIRC.....	3
					UOC:A15,B15,H15	

END OF FIGURE



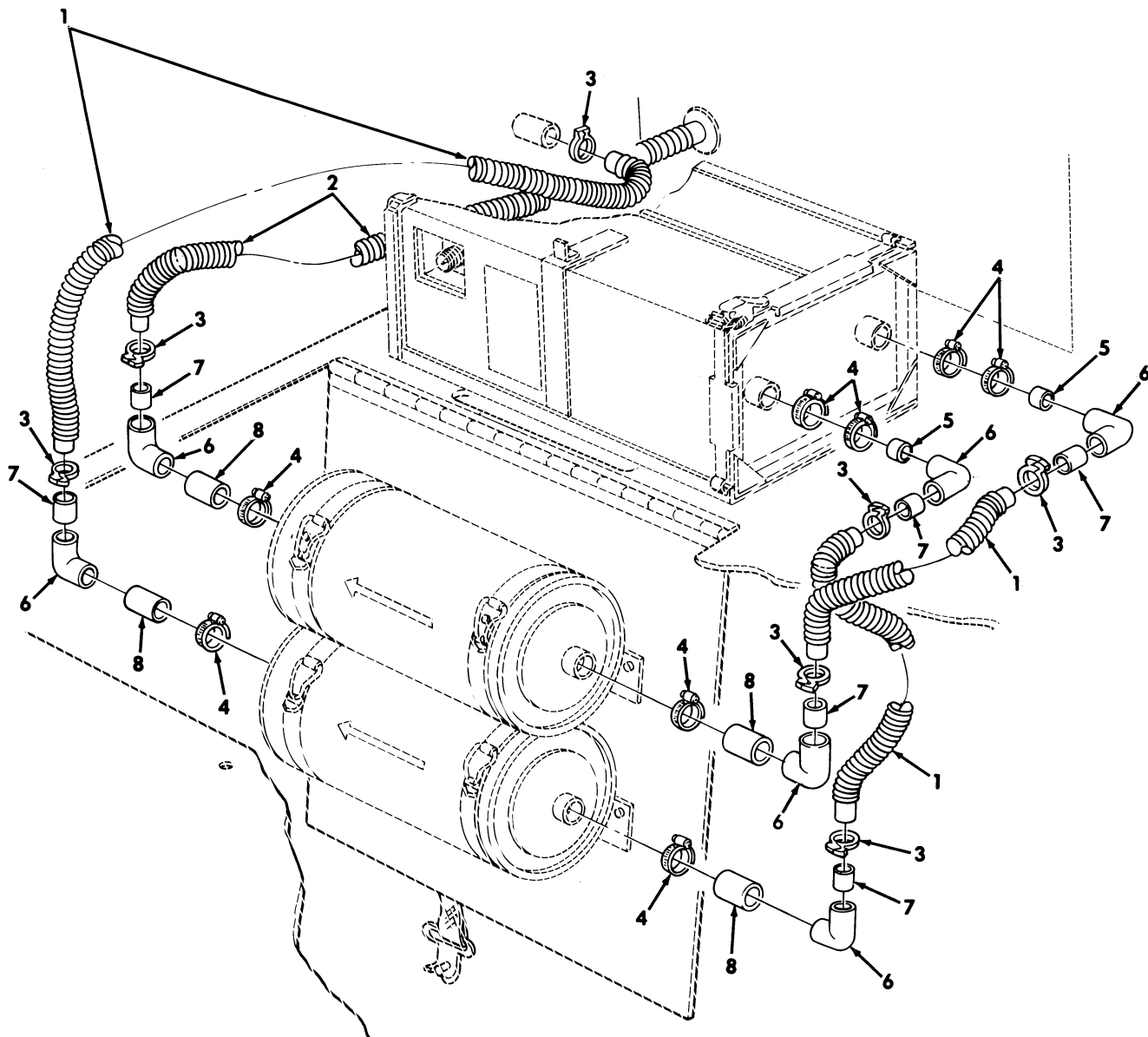

Figure 301. Hose Assembly, Blower to Filter, M996 and M996A1 Ambulance.

SECTION II			TM9-2320-280-24P			
(1)	(2)	(3)	(4)	(5)	(6)	(7)
ITEM	SMR			PART		
NO	CODE	NSN	CAGEC	NUMBER	DESCRIPTION AND USABLE ON CODES(UC)	QTY
GROUP 1812 SPECIAL PURPOSE BODIES						
FIG. 301 HOSE ASSEMBLY,BLOWER TO FILTER,M996 AND M996A1 AMBULANCE						
1	PAOZZ	4720012653237	19207	12341795-1	HOSE, NONMETALLIC.....	3
					UOC: B16, H16	
2	PAOZZ	4720012653222	19207	12341795-2	HOSE ASSEMBLY, NONME.....	1
					UOC: B16, H16	
3	PFOZZ	4730012384371	53421	SNP22	CLAMP, HOSE.....	7
					UOC: B16, H16	
4	PAOZZ	4730009083193	66295	WWD48-58H	CLAMP, HOSE.....	8
					UOC: B16, H16	
5	PFOZZ	4720013841212	19207	12341586-3	TUBING, NONMETALLIC.....	2
					UOC: B16, H16	
6	PAOZZ	4730012653166	19207	12341583	ELBOW, TUBE.....	6
					UOC: B16, H16	
7	MOOZZ		19207	12341587-20	TUBING, NONMETALLIC MAKE FROM PIPE, P/N D1785, 1.31 INCHES LONG.....	6
					UOC: B16, H16	
8	PAOZZ	4730012707931	34623	SF5597721	CONNECTOR, TUBING, ST.....	4
					UOC: B16, H16	

END OF FIGURE

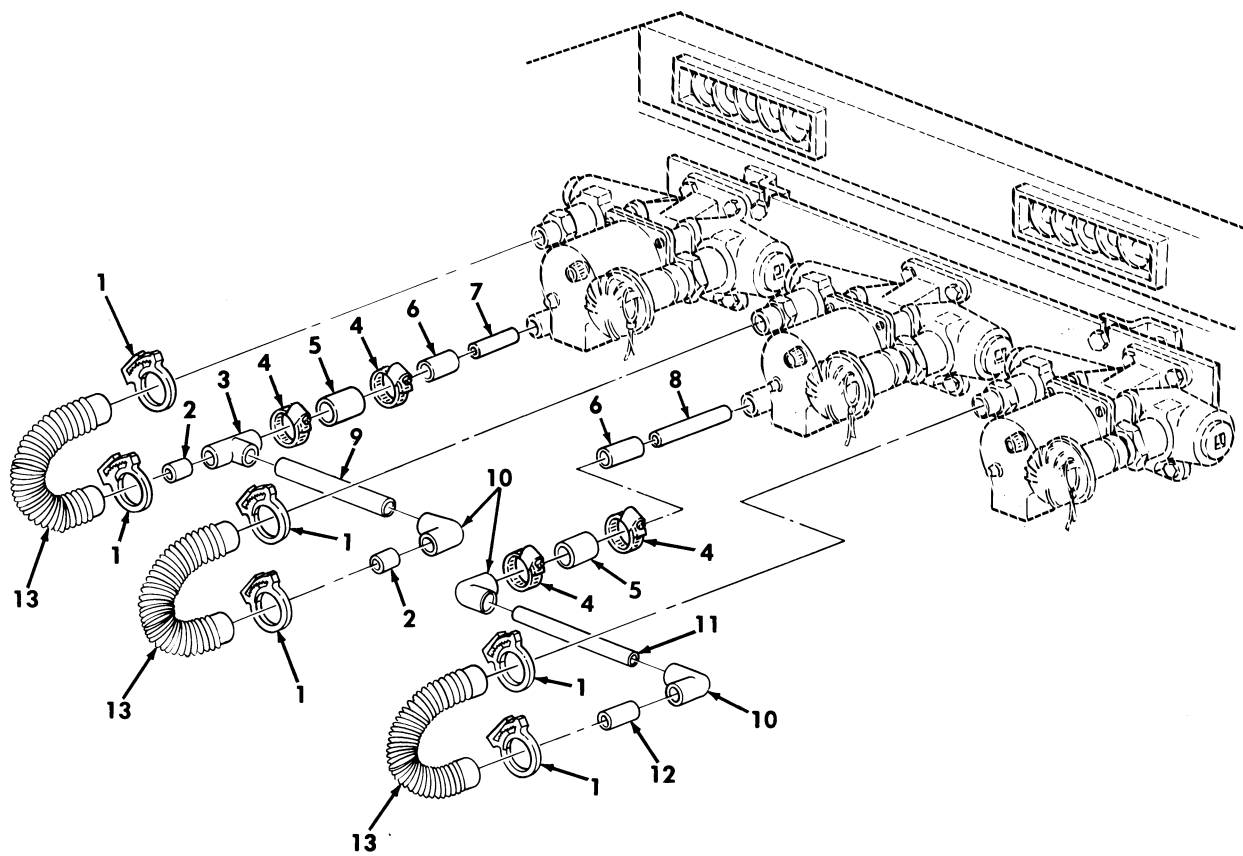

Figure 302. NBC Piping for # 1, 2, & 3 Heaters, M997, M997A1, and M997A2 Ambulance.

SECTION II			TM9-2320-280-24P			
(1)	(2)	(3)	(4)	(5)	(6)	(7)
ITEM	SMR			PART		
NO	CODE	NSN	CAGEC	NUMBER	DESCRIPTION AND USABLE ON CODES(UOC)	QTY
GROUP 1812 SPECIAL PURPOSE BODIES						
FIG. 302 NBC PIPING FOR #1,2,& 3 HEATERS,M997,M997A1,AND M997A2 AMBULANCE						
1	PAOZZ	4730013823165	34623	12341606-2	CLAMP,HOSE.....	6
					UOC:A15,B15,H15	
2	MOOZZ		34623	SF5597725	TUBING,NONMETALLIC MAKE FROM PIPE, P/N D1785,1.38 INCHES LONG.....	2
					UOC:A15,B15,H15	
3	PAOZZ	4730004767127	19207	12341584	TEE,PIPE 2.50.....	1
					UOC:A15,B15,H15	
4	PAOZZ	4730013229160	80205	NAS1922-0150	CLAMP,HOSE.....	4
					UOC:A15,B15,H15	
5	PAOZZ	4730012653284	34623	SF5597744	CONNECTOR,TUBING,ST.....	2
					UOC:A15,B15,H15	
6	PAOZZ	4730004765859	19207	12341585	COUPLING,PIPE 1.50.....	2
					UOC:A15,B15,H15	
7	MOOZZ		34623	SF5598134	TUBING MAKE FROM PIPE,P/N D1785, 3.03 INCHES LONG.....	1
					UOC:A15,B15,H15	
8	MOOZZ		34623	SF-5597223	TUBING,PVC MAKE FROM PIPE,P/N D1785,4.38 INCHES LONG.....	1
					UOC:A15,B15,H15	
9	MOOZZ		34623	SF5597958	TUBING,PCV MAKE FROM PIPE,P/N D1785,7.50 INCHES LONG.....	1
					UOC:A15,B15,H15	
10	PFOZZ	4730012653166	9C234	SF-5597234	ELBOW,TUBE.....	3
					UOC:A15,B15,H15	
11	MOOZZ		34623	SF5598132	TUBING,NONMETALLIC MAKE FROM PIPE, P/N D1785,10.28 INCHES LONG.....	1
					UOC:A15,B15,H15	
12	MOOZZ		34623	SF5598133	TUBING,NONMETALLIC MAKE FROM PIPE, P/N D1785,2.88 INCHES LONG.....	1
					UOC:A15,B15,H15	
13	PAOZZ	4720012653239	19207	12341862	HOSE,AIR DUCT.....	3
					UOC:A15,B15,H15	

END OF FIGURE

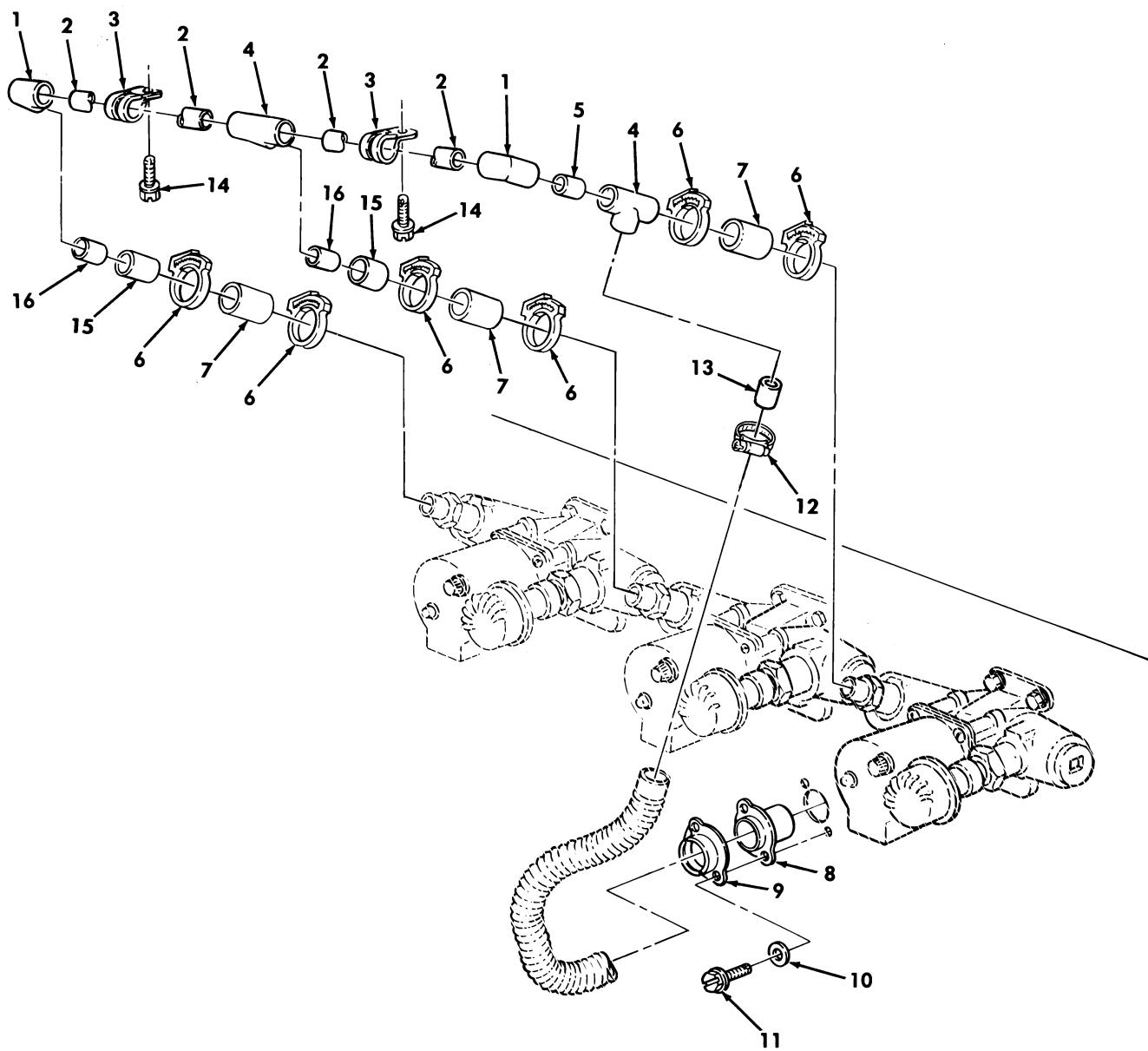

Figure 303. NBC Piping For # 1, 2, & 3 Heaters, M996 and M996A1 Ambulance.

SECTION II			TM9-2320-280-24P			
(1)	(2)	(3)	(4)	(5)	(6)	(7)
ITEM	SMR			PART		
NO	CODE	NSN	CAGEC	NUMBER	DESCRIPTION AND USABLE ON CODES(UOC)	QTY
GROUP 1812 SPECIAL PURPOSE BODIES						
FIG. 303 NBC PIPING FOR #1,2,& 3 HEATERS,M996 AND M996A1 AMBULANCE						
1	PFOZZ	4730012653166	19207	12341583	ELBOW,TUBE.....	2
					UOC:B16,H16	
2	MOOZZ		34623	SF5597958	TUBING,PCV MAKE FROM PIPE,P/N	4
					D1785,7.50 INCHES LONG.....	
					UOC:B16,H16	
3	PAOZZ	5340009588457	96906	MS21333-78	CLAMP,LOOP.....	2
					UOC:B16,H16	
4	PFOZZ	4730004767127	19207	12341584	TEE,PIPE 2.50.....	2
					UOC:B16,H16	
5	MOOZZ		34623	SF5597214	TUBING,PCV MAKE FROM PIPE,P/N	1
					D1785,1.62 INCHES LONG.....	
					UOC:B16,H16	
6	PAOZZ	4730009083193	66295	WWD48-58H	CLAMP,HOSE.....	6
					UOC:B16,H16	
7	PAOZZ	4720012709616	34623	SF5934202	TUBING,NONMETALLIC.....	3
					UOC:B16,H16	
8	PFOZZ	5365013812215	19207	12341231-6	BUSHING,NONMETALLIC.....	1
					UOC:B16,H16	
9	PFOZZ	2590004543620	19207	809223	RETAINER,ASSEMBLY.....	1
					UOC:B16,H16	
10	PAOZZ	5310000145850	96906	MS27183-42	WASHER,FLAT 7/32.....	2
					UOC:B16,H16	
11	PAOZA	5305010065736	02126	DR-T10X3/4	SCREW,TAPPING #10-32 X 3/4.....	2
					UOC:B16,H16	
12	PAOZZ	4730012395251	53421	SNP-22	CLAMP,HOSE.....	1
					UOC:B16,H16	
13	MOOZZ		19207	12341587-20	TUBING,NONMETALLIC MAKE FROM PIPE,	1
					P/N D1785,1.31 INCHES LONG.....	
					UOC:B16,H16	
14	PAOZZ	5305012596322	34623	12342499-1	SCREW,MACHINE #10-32 X .50.....	2
					UOC:B16,H16	
15	PFOZZ	4730004765859	19207	12341585	COUPLING,PIPE.....	2
					UOC:B16,H16	
16	MOOZZ		34623	SF5597957	CONNECTOR STRAIGHT MAKE FROM PIPE,	2
					P/N D1785,2.70 INCHES LONG.....	
					UOC:B16,H16	

END OF FIGURE

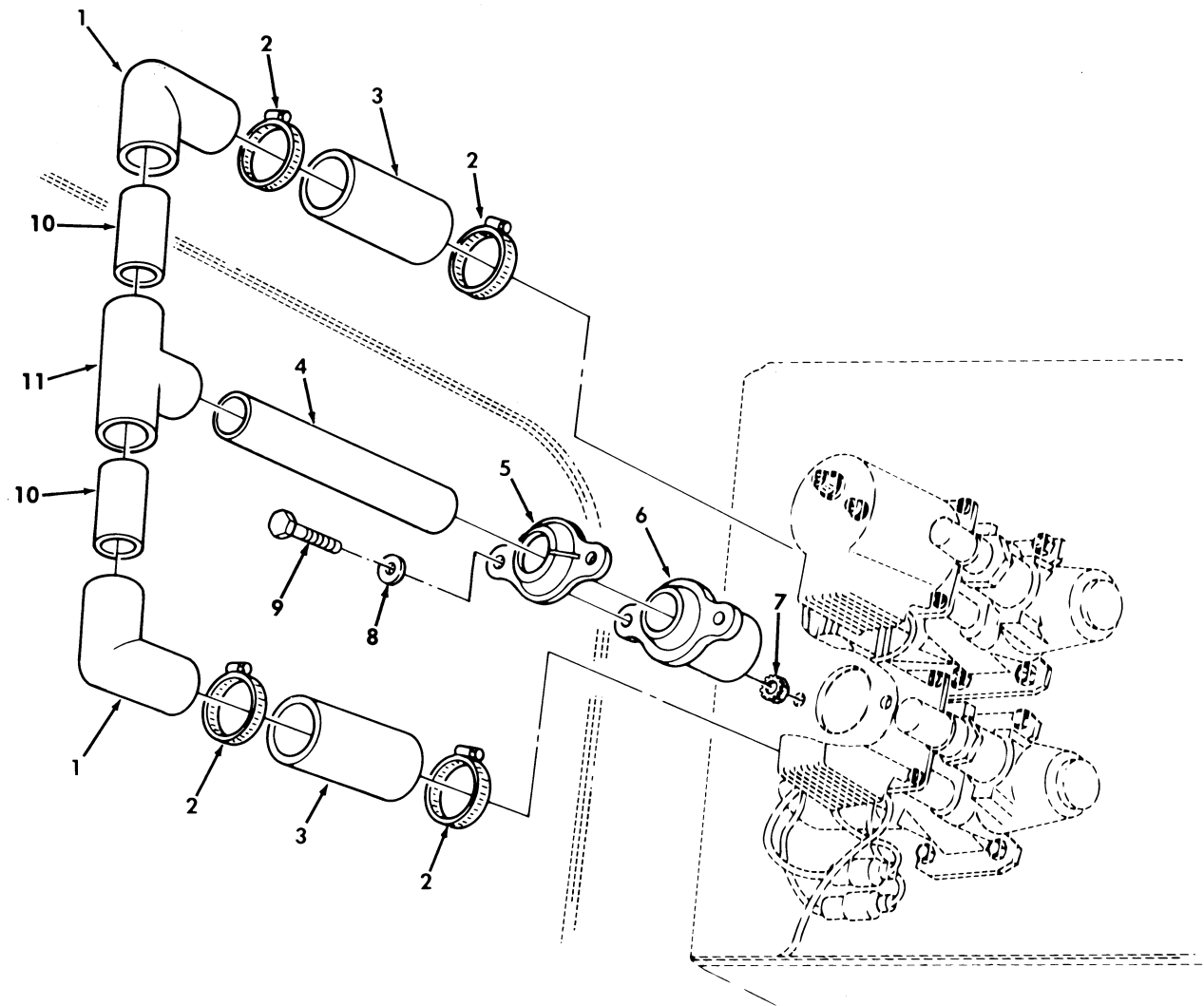

Figure 304. NBC Piping for # 4, & 5 Heaters, M996 and M996A1 Ambulance.

SECTION II			TM9-2320-280-24P			
(1)	(2)	(3)	(4)	(5)	(6)	(7)
ITEM	SMR			PART		
NO	CODE	NSN	CAGEC	NUMBER	DESCRIPTION AND USABLE ON CODES(UC)	QTY
GROUP 1812 SPECIAL PURPOSE BODIES						
FIG. 304 NBC PIPING FOR #4 & 5 HEATERS,M996 AND M996A1 AMBULANCE						
1	PAOZZ	4730012653166	19207	12341583	ELBOW,TUBE.....	2
					UOC:B16,H16	
2	PAOZZ	4730009083193	66295	WWD48-58H	CLAMP,HOSE.....	4
					UOC:B16,H16	
3	PAOZZ	4730012653285	19207	12341586	CONNECTOR,TUBING,ST.....	2
					UOC:B16,H16	
4	MOOZZ		34623	SF5597723	TUBING,NONMETALLIC MAKE FROM PIPE, P/N D1785,8.75 INCHES LONG.....	1
					UOC:B16,H16	
5	PAOZZ	2590004543620	19207	809223	RETAINER,ASSEMBLY.....	1
					UOC:B16,H16	
6	PAOZZ	5365013833722	19207	12341231-5	BUSHING,NONMETALLIC.....	1
					UOC:B16,H16	
7	PAOZZ	5310011520598	24617	271172	NUT,SELF-LOCKING,AS 1/4-20.....	2
					UOC:B16,H16	
8	PAOZZ	5310008094058	96906	MS27183-10	WASHER,FLAT 1/4.....	2
					UOC:B16,H16	
9	PAOZZ	5305012729042	34623	5593409	SCREW,CAP,HEXAGON H #10-32 X 3/4...	2
					UOC:B16,H16	
10	MOOZZ		34623	SF5597214	TUBING,PCV MAKE FROM PIPE, P/N D1785, 1.62 INCHES LONG.....	2
					UOC:B16,H16	
11	PAOZZ	4730004767127	19207	12341584	TEE,PIPE.....	1
					UOC:B16,H16	

END OF FIGURE



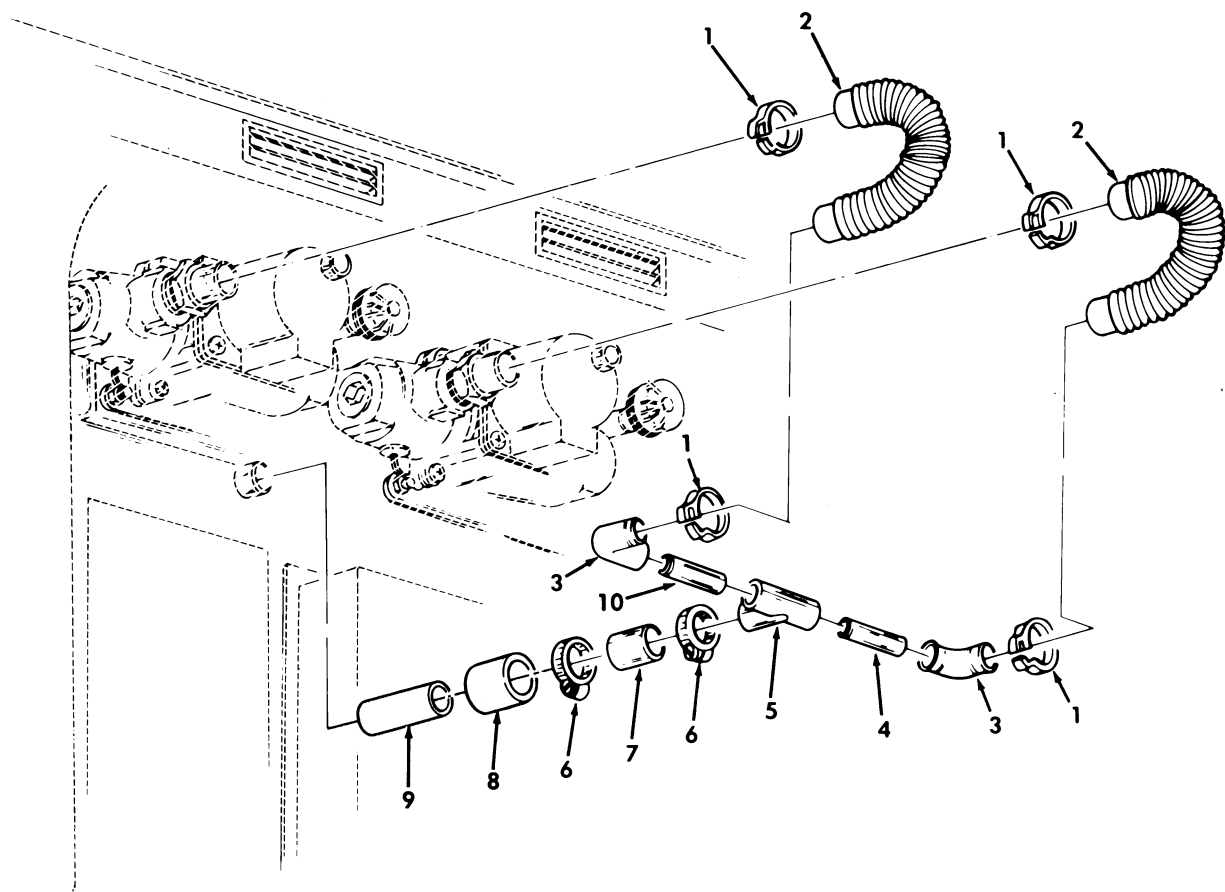

Figure 305. NBC Piping for # 4 & 5 Heaters, M997, M997A1, and M997A2 Ambulance.

SECTION II			TM9-2320-280-24P			
(1)	(2)	(3)	(4)	(5)	(6)	(7)
ITEM	SMR			PART		
NO	CODE	NSN	CAGEC	NUMBER	DESCRIPTION AND USABLE ON CODES(UOC)	QTY
GROUP 1812 SPECIAL PURPOSE BODIES						
FIG. 305 NBC PIPING FOR #4 & 5 HEATERS,M997,M997A1,AND M997A2 AMBULANCE						
1	PAOZZ	4730013823165	34623	12341606-2	CLAMP,HOSE.....	4
					UOC:A15,B15,H15	
2	PFOZZ	4720012653239	19207	12341862	HOSE,AIR DUCT.....	2
					UOC:A15,B15,H15	
3	PFOZZ	4730012653166	19207	12341583	ELBOW,TUBE.....	2
					UOC:A15,B15,H15	
4	MOOZZ		34623	SF-5597223	TUBING,PVC MAKE FROM PIPE,P/N	1
					D1785,4.38 INCHES LONG.....	
					UOC:A15,B15,H15	
5	PFOZZ	4730004767127	19207	12341584	TEE,PIPE.....	1
					UOC:A15,B15,H15	
6	PAOZZ	4730013229160	80205	NAS1922-0150-1	CLAMP,HOSE.....	2
					UOC:A15,B15,H15	
7	PFOZZ	4730012653284	34623	SF5597744	CONNECTOR,TUBING,ST.....	1
					UOC:A15,B15,H15	
8	PAOZZ	4730004765859	19207	12341585	COUPLING,PIPE.....	1
					UOC:A15,B15,H15	
9	MOOZZ		34623	SF5598134	TUBING MAKE FROM PIPE,P/N D1785,	1
					3.03 INCHES LONG.....	
					UOC:A15,B15,H15	
10	MOOZZ		34623	SF5597216	PIPE STRAIGHT MAKE FROM PIPE,P/N	1
					D1785,2 INCHES LONG.....	
					UOC:A15,B15,H15	

END OF FIGURE

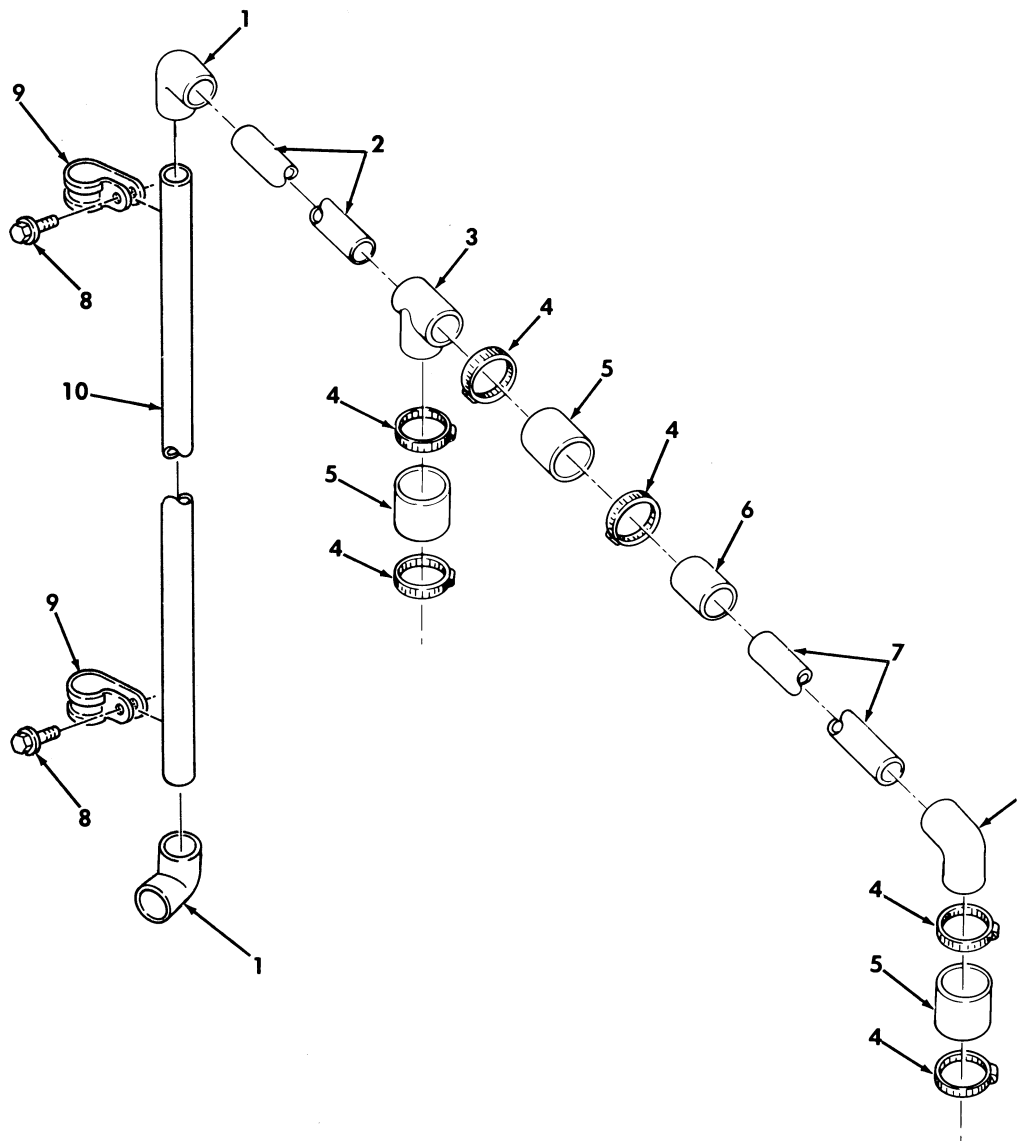

Figure 306. NBC Piping for #6 & 7 Heaters, M997, M997A1, and M997A2 Ambulance.

SECTION II			TM9-2320-280-24P			
(1)	(2)	(3)	(4)	(5)	(6)	(7)
ITEM	SMR			PART		
NO	CODE	NSN	CAGEC	NUMBER	DESCRIPTION AND USABLE ON CODES(UC)	QTY
GROUP 1812 SPECIAL PURPOSE BODIES						
FIG. 306 NBC PIPING FOR #6 & 7 HEATERS,M997,M997A1,AND M997A2 AMBULANCE						
1	PFOZZ	4730012653166	19207	12341583	ELBOW,TUBE.....	3
					UOC:A15,B15,H15	
2	MOOZZ		34623	SF5597229	PIPE,STRAIGHT,PVC MAKE FROM PIPE,P/N D1785,15.88 INCHES LONG.....	1
					UOC:A15,B15,H15	
3	PFOZZ	4730004767127	19207	12341584	TEE,PIPE 2.50.....	1
					UOC:A15,B15,H15	
4	PAOZZ	4730013229160	80205	NAS1922-0150-1	CLAMP,HOSE.....	6
					UOC:A15,B15,H15	
5	PFOZZ	4730012653285	19207	12341586	CONNECTOR,TUBING,ST.....	3
					UOC:A15,B15,H15	
6	PAOZZ	4730004765859	19207	12341585	COUPLING,PIPE 1.66 INCHES LONG.....	1
					UOC:A15,B15,H15	
7	MOOZZ		34623	SF5597230	PIPE,STRAIGHT,PVC MAKE FROM PIPE,P/N D1785,30.72 INCHES LONG.....	1
					UOC:A15,B15,H15	
8	PAOZZ	5305013615353	24617	9414241	SCREW,TAPPING.....	2
					UOC:A15,B15,H15	
9	PAOZZ	5340009226300	96906	MS21333-77	CLAMP,LOOP.....	2
					UOC:A15,B15,H15	
10	MOOZZ		34623	SF5597231	PIPE,STRAIGHT,PVC MAKE FROM PIPE,P/N D1785,31.38 INCHES LONG.....	1
					UOC:A15,B15,H15	

END OF FIGURE

13—14

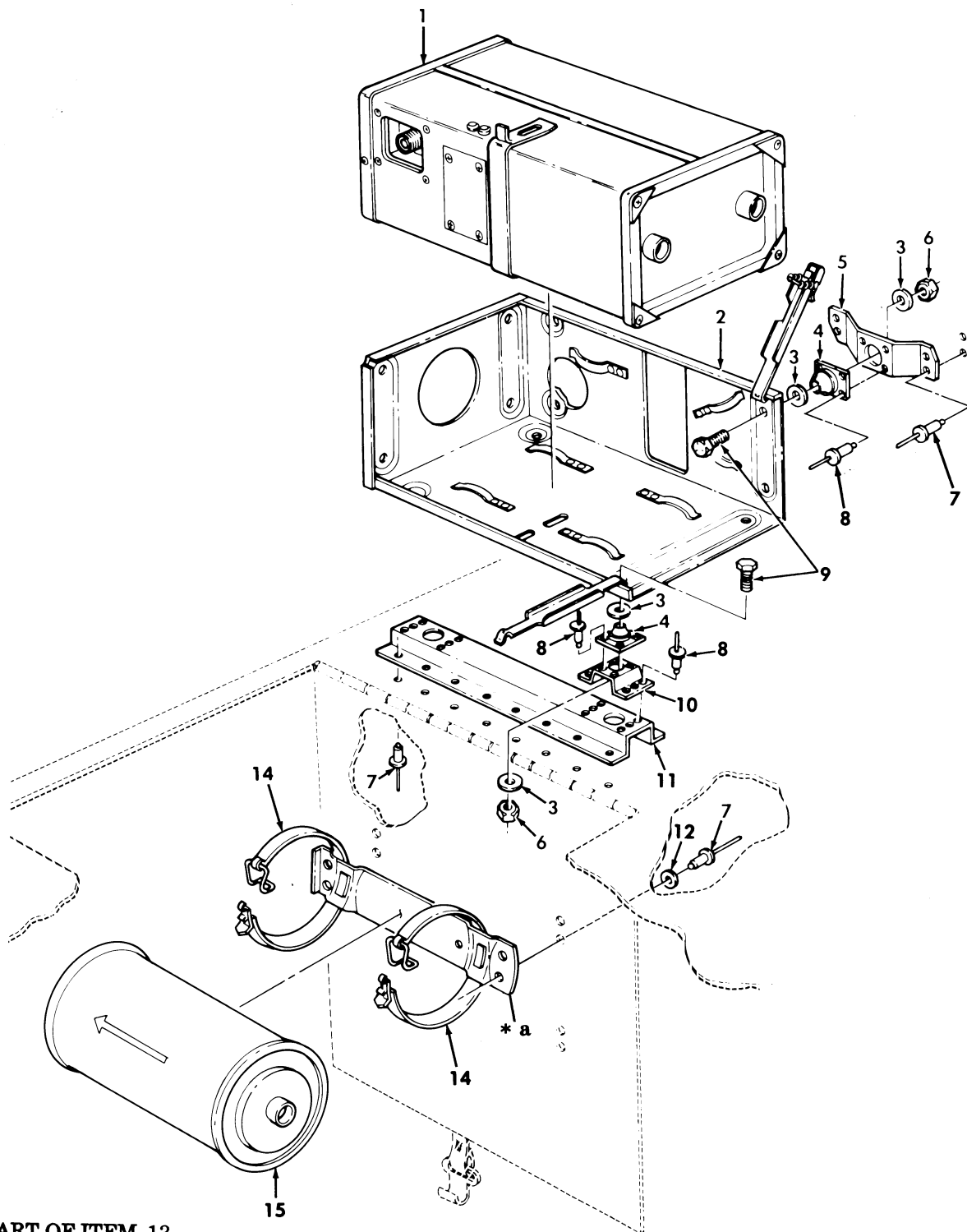
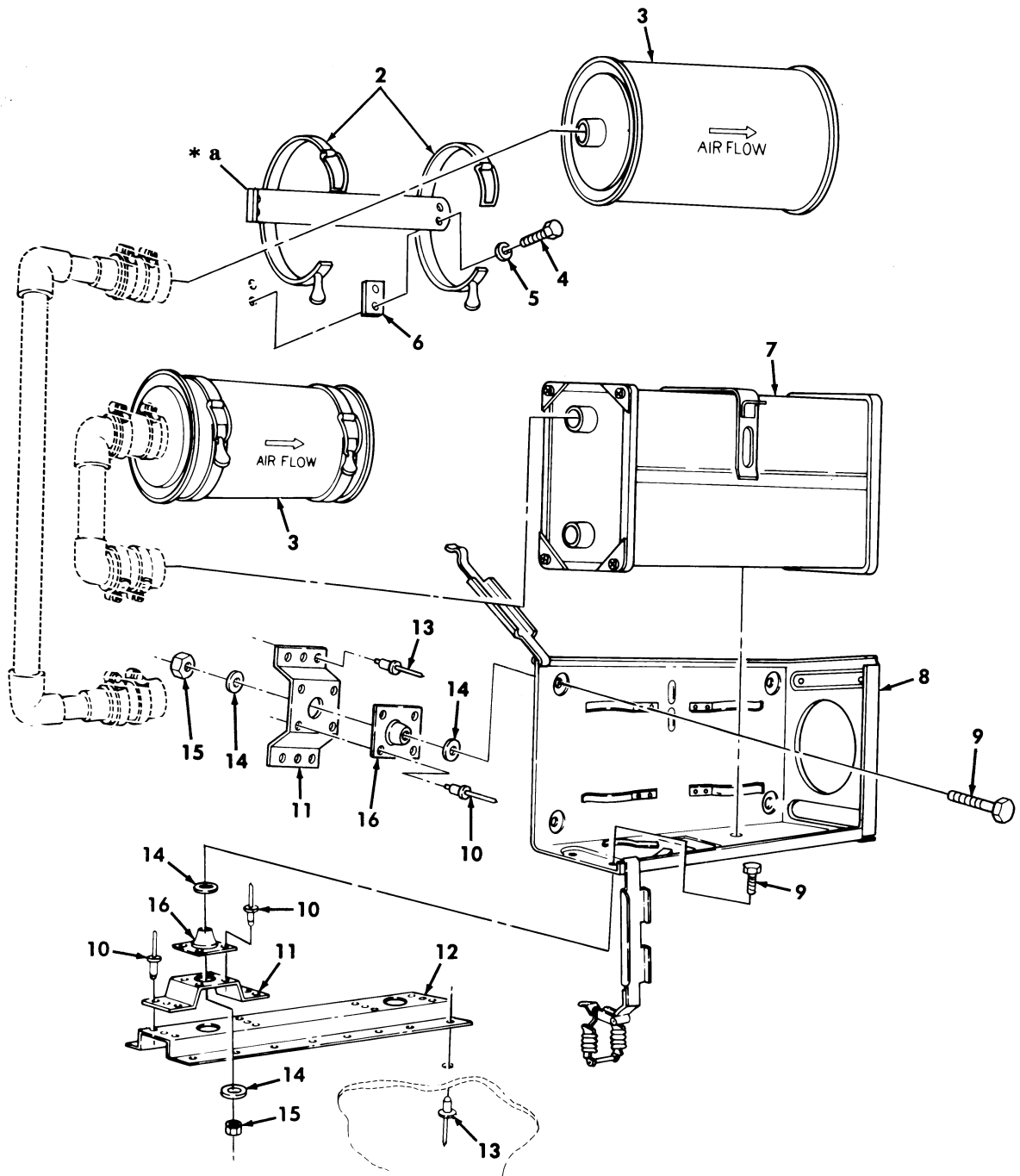

Figure 307. NBC Blower and Filter Mounting Hardware, M996 and M996A1 Ambulance.

SECTION II			TM9-2320-280-24P			
(1)	(2)	(3)	(4)	(5)	(6)	(7)
ITEM NO	SMR CODE	NSN	CAGEC	PART NUMBER	DESCRIPTION AND USABLE ON CODES(UOC)	QTY
GROUP 1812 SPECIAL PURPOSE BODIES						
FIG. 307 NBC BLOWER AND FILTER MOUNTING HARDWARE,M996 AND M996A1 AMBULANCE						
1	PAOZA	4240010263112	81361	D5-19-2353	PRECLEANER AND PART.....	1
					UOC:B16,H16	
2	PAOZZ	4240005656059	81361	D5-19-1754	FRAME ASSEMBLY.....	1
					UOC:B16,H16	
3	PAOZZ	5310001670893	88044	AN8013-2	WASHER,FLAT.....	10
					UOC:B16,H16	
4	PAOZZ	5342002007564	88044	AN8008D6	MOUNT,RESILIENT.....	5
					UOC:B16,H16	
5	PAOZZ	5340012912301	34623	5598285	BRACKET,MOUNTING.....	1
					UOC:B16,H16	
6	PAOZZ	5310012538380	34623	5592818	NUT.....	5
					UOC:B16,H16	
7	PAOZZ	5320012645978	19207	12339355-2	RIVET,BLIND 3/16 DIA., .247-.437... GRIP LENGTH.....	31
					UOC:B16,H16	
8	PAOZZ	5320012716357	9K475	MGLP-B6-4	RIVET,BLIND 3/16 DIA, .062-.270.... GRIP LENGTH.....	44
					UOC:B16,H16	
9	PAOZZ	5305000680501	96906	MS90725-5	SCREW,CAP,HEXAGON H 1/4-20 X 1.125 INCHES.....	5
					UOC:B16,H16	
10	PAOZZ	5340012886550	34623	5598279	BRACKET,MOUNTING LOWER.....	4
					UOC:B16,H16	
11	PAOZZ	5340012894474	34623	5598286	BRACKET,MOUNTING.....	2
					UOC:B16,H16	
12	PAOZZ	5310012349416	96906	MS51412-2	WASHER,FLAT 3/16.....	16
					UOC:B16,H16	
13	PFOZZ	5342012707921	19207	12341714	BRACKET,ENGINE ACCE.....	2
					UOC:B16,H16	
14	PAOZZ	5340014263850	54905	10084	.CLAMP,LOOP.....	2
					UOC:B16,H16	
15	PAOZZ	4240013650982	81361	5-19-2300	FILTER,GAS.....	2
					UOC:B16,H16	

END OF FIGURE

1-2



\* a PART OF ITEM 1

Figure 308. NBC Blower and Filter Mounting Hardware, M997, M997A1, and M997A2 Ambulance.

SECTION II			TM9-2320-280-24P			
(1)	(2)	(3)	(4)	(5)	(6)	(7)
ITEM	SMR			PART		
NO	CODE	NSN	CAGEC	NUMBER	DESCRIPTION AND USABLE ON CODES(UOC)	QTY
GROUP 1812 SPECIAL PURPOSE BODIES						
FIG. 308 NBC BLOWER AND FILTER MOUNTING HARDWARE, M997, M997A1, AND M997A2 AMBULANCE						
1	PAOOO	5342012707921	19207	12341714	BRACKET, ENGINE ACCE.....	2
					UOC:A15, B15, H15	
2	PAOZZ	5340014263850	54905	10084	. CLAMP, LOOP.....	2
					UOC:A15, B15, H15	
3	PAOZZ	4240008283952	81361	D5-19-2350	FILTER, GAS.....	2
					UOC:A15, B15, H15	
4	PAOZZ	5305010750957	96906	MS51849-100	SCREW, MACHINE 1/4-20 X 1.50.....	8
					UOC:A15, B15, H15	
5	PAOZZ	5310005825965	96906	MS35338-44	WASHER, LOCK 1/4.....	8
					UOC:A15, B15, H15	
6	PFOZZ	5365012729082	19207	12341401	SPACER, PLATE.....	4
					UOC:A15, B15, H15	
7	PAOZA	4240010263112	81361	D5-19-2353	PRECLEANER AND PART.....	1
					UOC:A15, B15, H15	
8	PAOZZ	4240005656059	81361	D5-19-1754	FRAME ASSEMBLY.....	1
					UOC:A15, B15, H15	
9	PAOZZ	5305002253842	80204	B1821BH025C113N	SCREW, CAP, HEXAGON H 1/4-20 X 1.125.	4
					UOC:A15, B15, H15	
10	PAOZZ	5320012716357	9K475	MGLP-B6-4	RIVET, BLIND 3/16 DIA. .062-.270....	24
					GRIP LENGTH.....	
					UOC:A15, B15, H15	
11	PFOZZ	5340012886550	34623	5598279	BRACKET, MOUNTING.....	4
					UOC:A15, B15, H15	
12	PFOZZ	5340012895055	34623	5598278	BRACKET, MOUNTING.....	1
					UOC:A15, B15, H15	
13	PAOZZ	5320012645978	19207	12339355-2	RIVET, BLIND 3/16 DIA, .214-.437....	18
					GRIP.....	
					UOC:A15, B15, H15	
14	PAOZZ	5310001670893	88044	AN8013-2	WASHER, FLAT 1/4.....	8
					UOC:A15, B15, H15	
15	PAOZZ	5310012538380	34623	5592818	NUT.....	4
					UOC:A15, B15, H15	
16	PFOZZ	5342002007564	88044	AN8008D6	MOUNT, RESILIENT.....	4
					UOC:A15, B15, H15	

END OF FIGURE



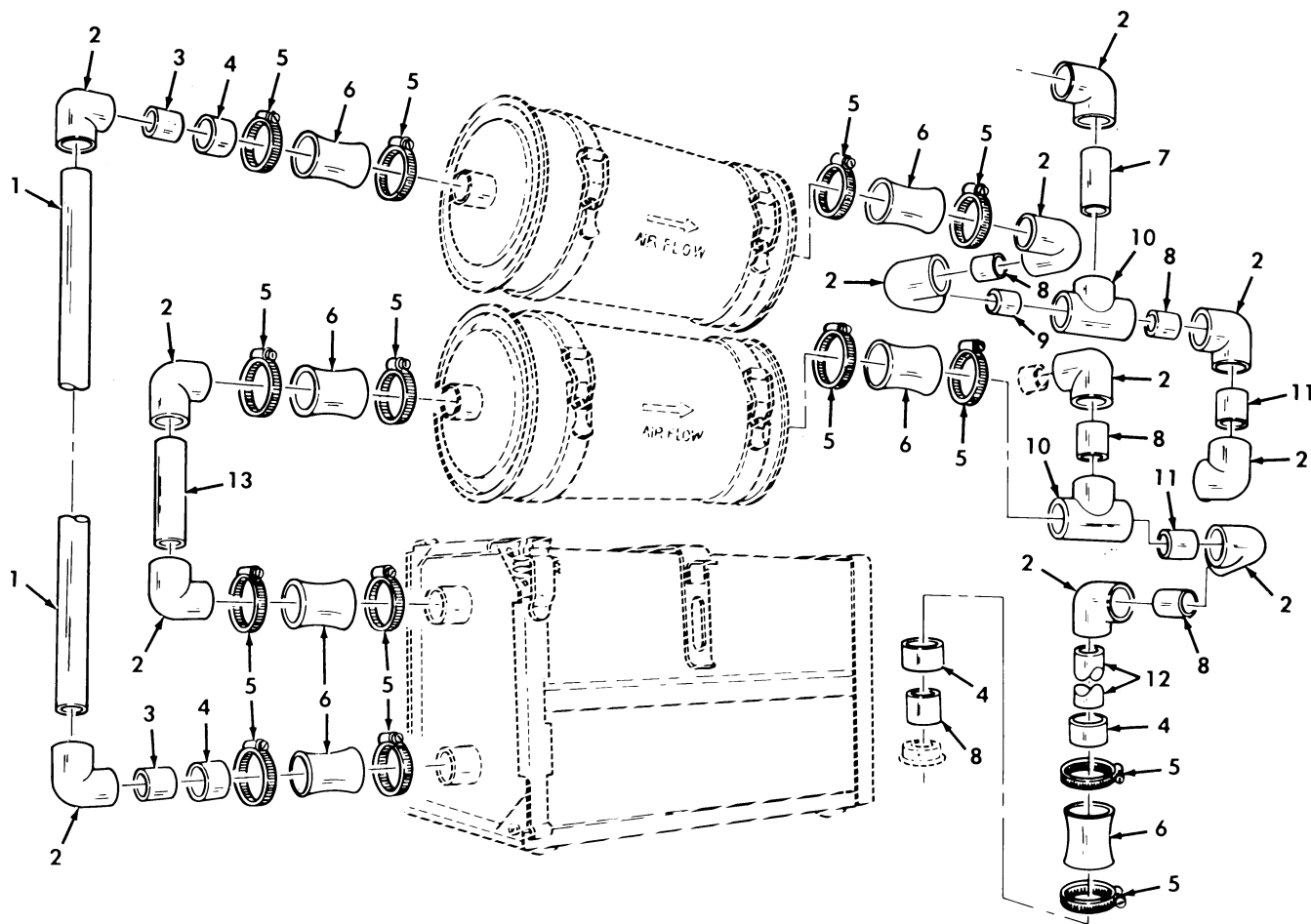

Figure 309. NBC Piping, Blower Box, and Filter, M997, M997A1, and M997A2 Ambulance.

SECTION II			TM9-2320-280-24P			
(1)	(2)	(3)	(4)	(5)	(6)	(7)
ITEM	SMR			PART		
NO	CODE	NSN	CAGEC	NUMBER	DESCRIPTION AND USABLE ON CODES(UOC)	QTY
GROUP 1812 SPECIAL PURPOSE BODIES						
FIG. 309 NBC PIPING,BLOWER BOX,AND FILTER,M997,M997A1,AND M997A2 AMBULANCE						
1	MOOZZ		34623	SF5597228	PIPE,STRAIGHT,PVC MAKE FROM PIPE,P/N D1785,15.31 INCHES LONG.....	1
					UOC:A15,B15,H15	
2	PFOZZ	4730012653166	19207	12341583	ELBOW,TUBE.....	12
					UOC:A15,B15,H15	
3	MOOZZ		34623	SF5597218	PIPE,STRAIGHT,PVC MAKE FROM PIPE,P/N D1785,2.38 INCHES LONG.....	2
					UOC:A15,B15,H15	
4	PFOZZ	4730004765859	19207	12341585	COUPLING,PIPE.....	4
					UOC:A15,B15,H15	
5	PAOZZ	4730013229160	80205	NAS1922-0150-1	CLAMP,HOSE.....	14
					UOC:A15,B15,H15	
6	PFOZZ	4730012653285	19207	12341586	CONNECTOR,TUBING,ST.....	7
					UOC:A15,B15,H15	
7	MOOZZ		34623	SF5597219	PIPE,STRAIGHT,PVC MAKE FROM PIPE,P/N D1785, 3.75 INCHES LONG.....	1
					UOC:A15,B15,H15	
8	MOOZZ		34623	SF5597214	TUBING,PCV MAKE FROM PIPE, P/N D1785, 1.62 INCHES LONG.....	5
					UOC:A15,B15,H15	
9	MOOZZ		34623	SF5597215	PIPE,STRAIGHT,PVC MAKE FROM PIPE, P/N D1785, 1.81 INCHES LONG.....	1
					UOC:A15,B15,H15	
10	PFOZZ	4730004767127	19207	12341584	TEE,PIPE.....	2
					UOC:A15,B15,H15	
11	MOOZZ		34623	SF5597217	PIPE,STRAIGHT MAKE FROM PIPE, P/N D1785, 2.12 INCHES LONG.....	2
					UOC:A15,B15,H15	
12	MOOZZ		34623	SF5597227	PIPE,STRAIGHT,PVC MAKE FROM PIPE, P/N D1785, 10.62 INCHES LONG.....	1
					UOC:A15,B15,H15	
13	MOOZZ		34623	SF5597221	PIPE,STRAIGHT,PVC MAKE FROM PIPE, P/N D1785, 4.75 INCHES LONG.....	1
					UOC:A15,B15,H15	

END OF FIGURE

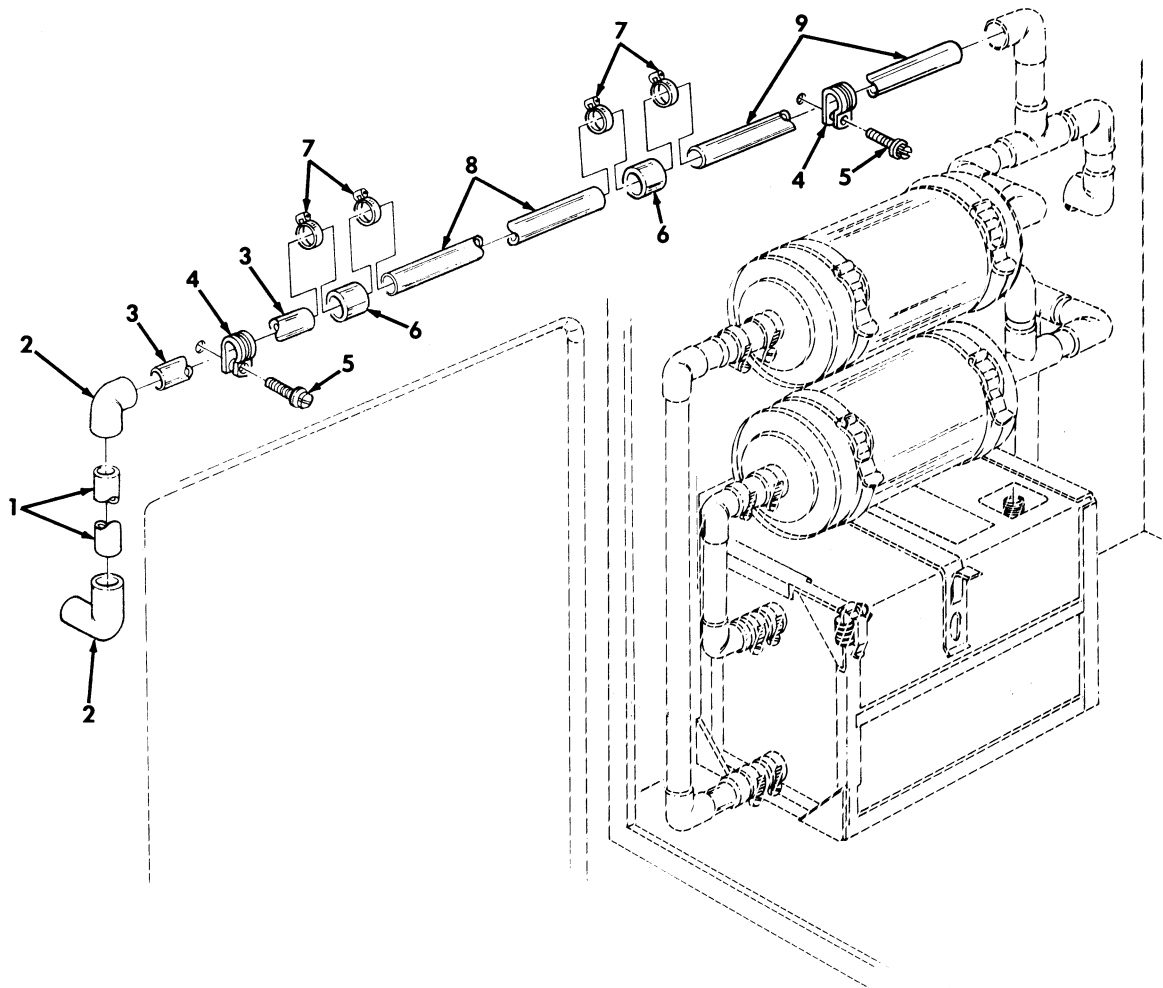
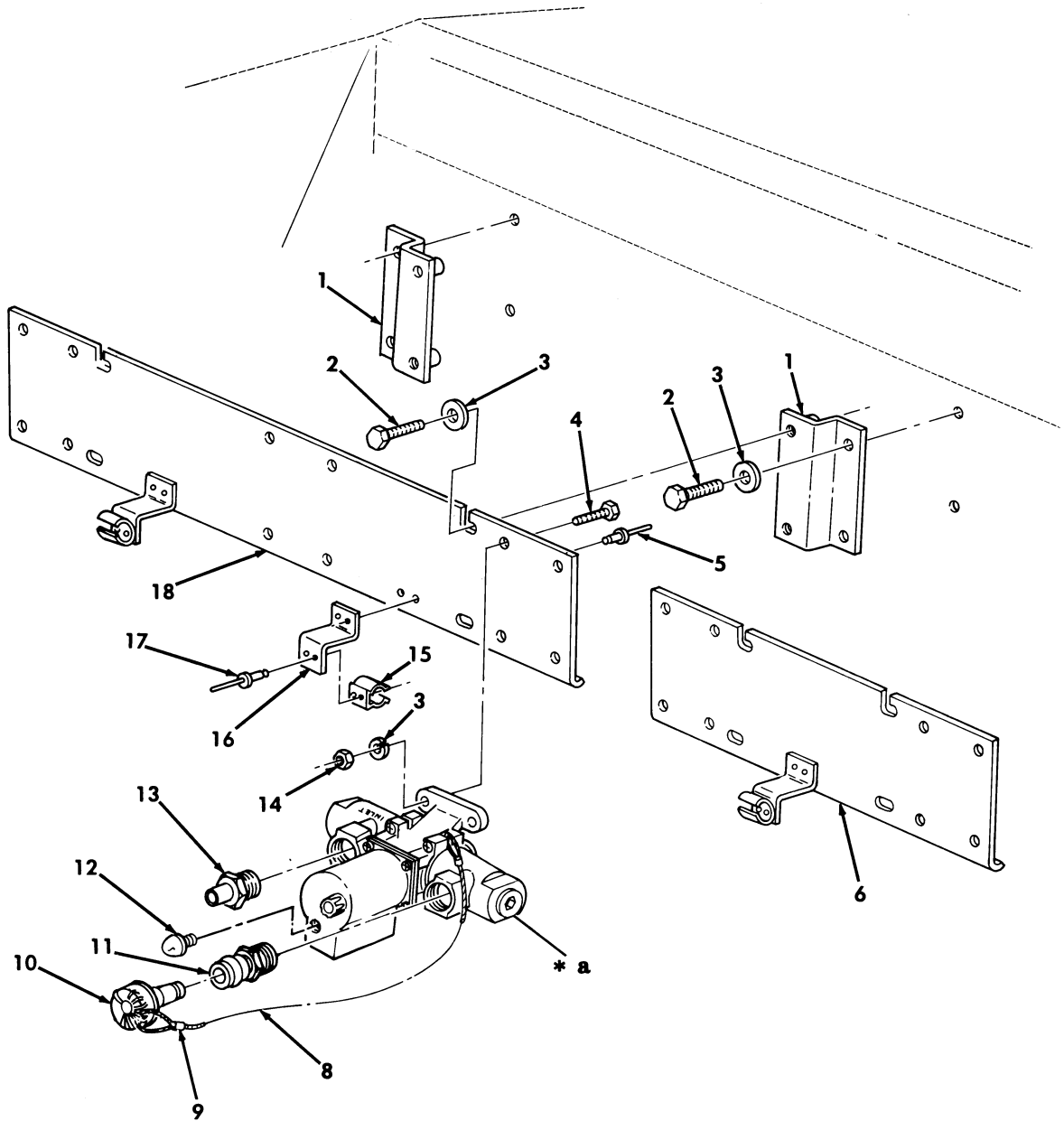

Figure 310. NBC Tubing from Filters to Heaters, M997, M997A1, and M997A2 Ambulance.

SECTION II			TM9-2320-280-24P			
(1)	(2)	(3)	(4)	(5)	(6)	(7)
ITEM	SMR			PART		
NO	CODE	NSN	CAGEC	NUMBER	DESCRIPTION AND USABLE ON CODES(UOC)	QTY
GROUP 1812 SPECIAL PURPOSE BODIES						
FIG. 310 NBC TUBING FROM FILTERS TO HEATERS,M997,M997A1,AND M997A2 AMBULANCE						
1	MOOZZ		34623	SF5597226	TUBING MAKE FROM PIPE,P/N D1785, 6.87 INCHES LONG.....	1
					UOC:A15,B15,H15	
2	PAOZZ	4730012653166	19207	12341583	ELBOW,TUBE.....	2
					UOC:A15,B15,H15	
3	MOOZZ		34623	SF5597232	TUBING,NONMETALLIC MAKE FROM PIPE, P/N D1785,6.81 INCHES LONG.....	1
					UOC:A15,B15,H15	
4	PAOZZ	5340009226300	96906	MS21333-77	CLAMP,LOOP.....	2
					UOC:A15,B15,H15	
5	PAOZZ	5305012596322	34623	12342499-1	SCREW,MACHINE #10-32 X .50.....	2
					UOC:A15,B15,H15	
6	PAOZZ	4730004765859	19207	12341585	COUPLING,PIPE.....	2
					UOC:A15,B15,H15	
7	PAOZZ	4730009083194	96906	MS35842-11	CLAMP,HOSE.....	4
					UOC:A15,B15,H15	
8	PAOZZ	4720012709618	19207	12341614	TUBING,NONMETALLIC.....	1
					UOC:A15,B15,H15	
9	MOOZZ		34623	SF5597970	TUBING MAKE FROM PIPE,P/N D1785, 14.12 INCHES LONG.....	1
					UOC:A15,B15,H15	

END OF FIGURE

7—  
8  
thru  
13



\* a PART OF ITEM 7

Figure 311. NBC Heater and Mounting Hardware, M997, M997A1, and M997A2 Ambulance.

SECTION II			TM9-2320-280-24P			
(1)	(2)	(3)	(4)	(5)	(6)	(7)
ITEM	SMR			PART		
NO	CODE	NSN	CAGEC	NUMBER	DESCRIPTION AND USABLE ON CODES(UOC)	QTY
GROUP 1812 SPECIAL PURPOSE BODIES						
FIG. 311 NBC HEATER AND MOUNTING HARDWARE, M997, M997A1, AND M997A2 AMBULANCE						
1	PFOZZ	5340012727712	19207	12341863	BRACKET, MOUNTING.....	4
					UOC:A15, B15, H15	
2	PAOZZ	5305000680502	96906	MS90725-6	SCREW, CAP, HEXAGON H 1/4-20 X 3/4...	24
					UOC:A15, B15, H15	
3	PAOZZ	5310005825965	96906	MS35338-44	WASHER, LOCK 1/4.....	36
					UOC:A15, B15, H15	
4	PAOZZ	5305000712505	80204	B1821BH025C088N	SCREW, CAP, HEXAGON H 1/4-20 X 7/8...	20
					UOC:A15, B15, H15	
5	PFOZZ	5320000835009	11078	ADS43	RIVET, BLIND 1/8 DIA, .126-.187 GRIP	6
					UOC:A15, B15, H15	
6	PFOZZ	2540012711954	19207	12341814	PLATE, MOUNTING, GROM R.H.....	1
					UOC:A15, B15, H15	
7	PAOOO	4240008076856	81361	E5-19-1782	HEATER, AIR, ELECTRIC.....	7
					UOC:A15, B15, H15	
8	MOOZZ		34623	5597768	.ROPE, WIRE MAKE FROM ROPE, WIRE, P/N	1
					MIL-W-83420/2-002, 14 INCHES LONG....	
					UOC:A15, B15, H15	
9	PFOZZ	4030012727573	34623	5597769	.FERRULE, WIRE ROPE.....	2
					UOC:A15, B15, H15	
10	PAOZZ	4240000079453	81361	B5-19-1829	.CONNECTOR, ORIFICE A.....	1
					UOC:A15, B15, H15	
11	PFOZZ	4730012709652	19207	12341414	.COUPLING HALF, QUICK.....	1
					UOC:A15, B15, H15	
12	PAOZZ	6210005787970	83330	8-1930-0112-912	.LIGHT, INDICATOR.....	1
					UOC:A15, B15, H15	
13	PAOZZ	4730008085090	81361	B5-19-1676-1	.ADAPTER, STRAIGHT, PI.....	1
					UOC:A15, B15, H15	
14	PAOZZ	5310009050762	96906	MS51967-3	NUT, PLAIN, HEXAGON 1/4-20.....	20
					UOC:A15, B15, H15	
15	PFOZZ	5340012821115	81349	M24066-2-354	CLIP, SPRING TENSION.....	3
					UOC:A15, B15, H15	
16	PFOZZ	5340012805985	34623	5598124	BRACKET, DOUBLE ANGL.....	3
					UOC:A15, B15, H15	
17	PAOZZ	5320000835009	81349	M24243/1-A403	RIVET, BLIND 1/8 DIA., 0.126-.187	6
					GRIP.....	
					UOC:A15, B15, H15	
18	PFOZZ	2540012711955	19207	12341813	PLATE, MOUNTING, GROM L.H.....	1
					UOC:A15, B15, H15	

END OF FIGURE

3—  
4  
thru  
9

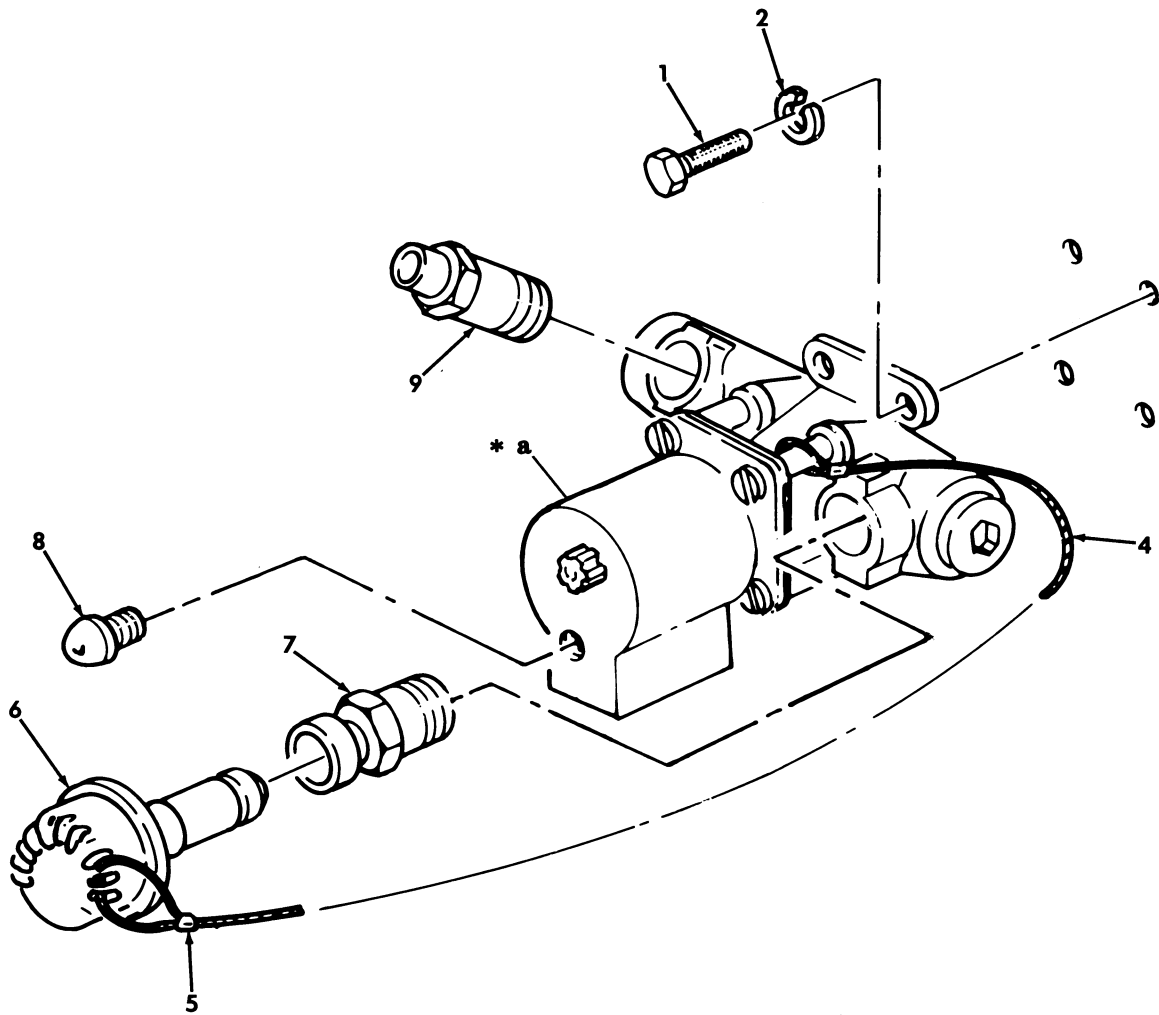

\* a PART OF ITEM 3

Figure 312. NBC Heater and Mounting Hardware, M996 and M996A1 Ambulance.

SECTION II			TM9-2320-280-24P			
(1)	(2)	(3)	(4)	(5)	(6)	(7)
ITEM	SMR			PART		
NO	CODE	NSN	CAGEC	NUMBER	DESCRIPTION AND USABLE ON CODES(UOC)	QTY
GROUP 1812 SPECIAL PURPOSE BODIES						
FIG. 312 NBC HEATER AND MOUNTING HARDWARE,M996 AND M996A1 AMBULANCE						
1	PAOZZ	5305002253843	80204	B1821BH025C100N	SCREW,CAP,HEXAGON H 1/4-20 X 1.00..	20
					UOC:B16,H16	
2	PAOZZ	5310008094058	96906	MS27183-10	WASHER,FLAT 1/4.....	20
					UOC:B16,H16	
3	PAOOO	4240008076856	81361	E5-19-1782	HEATER,AIR,ELECTRIC.....	5
					UOC:B16,H16	
4	MOOZZ		34623	5597768	.ROPE,WIRE MAKE FROM ROPE,WIRE,P/N	1
					MIL-W-83240/2-002,14 INCHES LONG....	
					UOC:B16,H16	
5	PAOZZ	4030012727573	34623	5597769	.FERRULE,WIRE ROPE.....	2
					UOC:B16,H16	
6	PAOZA	4240000079453	81361	B5-19-1829	.CONNECTOR,ORIFICE A.....	1
					UOC:B16,H16	
7	PAOZZ	4730012709652	19207	12341414	.COUPLING HALF,QUICK.....	1
					UOC:B16,H16	
8	PAOZZ	6210005787970	83330	8-1930-0112-912	.LIGHT,INDICATOR.....	1
					UOC:B16,H16	
9	PAOZZ	4730008085090	81361	B5-19-1676-1	.ADAPTER,STRAIGHT,PI.....	1
					UOC:B16,H16	

END OF FIGURE



Section II.

TM 9-2320-280-24P-1

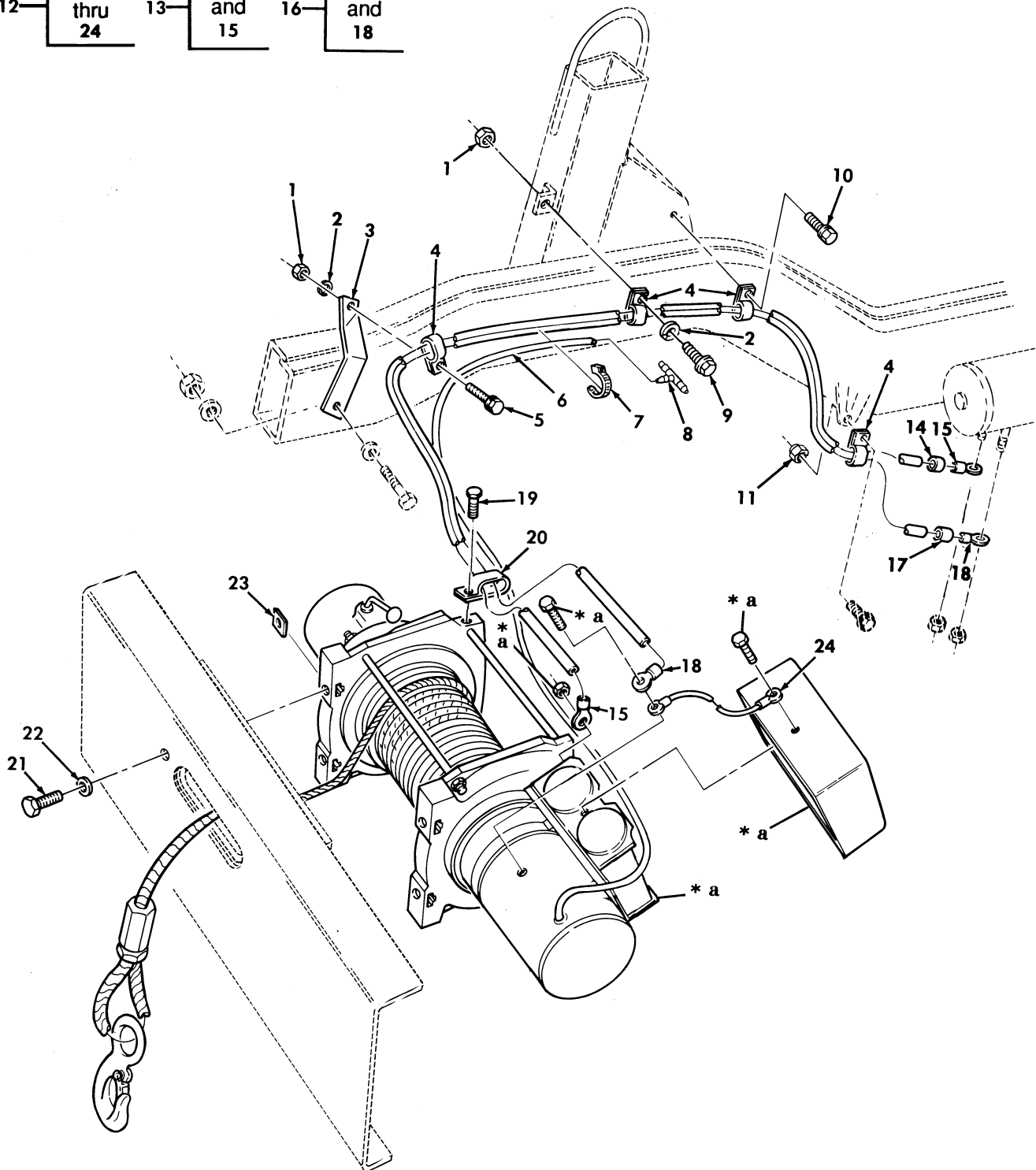
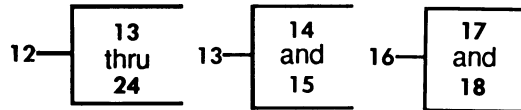

\* a PART OF ITEM 12

Figure 313. Winch Assembly, Mounting Hardware, and Related Parts.

SECTION II			TM9-2320-280-24P			
(1)	(2)	(3)	(4)	(5)	(6)	(7)
ITEM	SMR			PART		
NO	CODE	NSN	CAGEC	NUMBER	DESCRIPTION AND USABLE ON CODES(UOC)	QTY
					GROUP 20 HOIST,WINCH,CAPSTAN, WINDLASS,POWER CONTROL UNIT,AND POWER TAKE-OFF 2001 HOIST,CAPSTAN,WINDLASS, CRANE OR WINCH ASSEMBLY	
					FIG. 313 WINCH ASSEMBLY,MOUNTING HARDWARE,AND RELATED PARTS	
1	PAOZZ	5310009050762	96906	MS51967-3	NUT,PLAIN,HEXAGON 1/4-20.....	2
					UOC:A14,A26,A27,B18,H14,H18,H26,H27, H28	
2	PAOZZ	5310005825965	96906	MS35338-44	WASHER,LOCK 1/4.....	2
					UOC:A14,A26,A27,B18,H14,H18,H26,H27, H28	
3	PPFZZ	5340012669173	19207	12338481	BRACKET,DOUBLE ANGL.....	1
					UOC:A14,A26,A27,B18,H14,H18,H26,H27, H28	
4	PAOZZ	5340004381833	19207	7721654	CLAMP,LOOP.....	4
					UOC:A14,A26,A27,B18,H14,H18,H26,H27, H28	
5	PAOZZ	5305009881725	96906	MS35206-281	SCREW,MACHINE 1/4-20 X 3/4.....	1
					UOC:A14,A26,A27,B18,H14,H18,H26,H27, H28	
6	MOOZZ		19207	CPR104420-1-70	TUBING,NONMETALLIC MAKE FROM TUBING,P/N CPR104420-1,70 INCHES LONG.....	1
					UOC:A14,A26,A27,B18,H14,H18,H26,H27, H28	
7	PAOZZ	5975012055379	96906	MS3367-7	STRAP,TIEDOWN,ELECT.....	4
					UOC:A14,A26,A27,B18,H14,H18,H26,H27, H28	
8	PAOZZ	4730010035105	79470	1064X4	TEE,HOSE.....	1
					UOC:A14,A26,A27,B18,H14,H18,H26,H27, H28	
9	PAOZZ	5305000680502	96906	MS90725-6	SCREW,CAP,HEXAGON H 1/4-20 X 3/4...	1
					UOC:A14,A26,A27,B18,H14,H18,H26,H27, H28	
10	PAOZZ	5305001913640	96906	MS51851-85	SCREW,TAPPING 1/4-20 X 5/8.....	1
					UOC:A14,A26,A27,B18,H14,H18,H26,H27, H28	
11	PAOZZ	5310011520598	24617	271172	NUT,SELF-LOCKING,AS 1/4-20.....	1
					UOC:A14,A26,A27,B18,H14,H18,H26,H27, H28	
12	XBOFF		27647	W6000HMV	WINCH,DRUM,VEHICLE.....	1
					UOC:A14,A26,A27,B18,H14,H18,H26,H27, H28	
13	MOOZZ		27647	15847	.CABLE ASSY,ELECTRIC MAKE FROM WIRE,P/N M13486/1-11, 77 INCHES LONG	1
					UOC:A14,A26,A27,B18,H14,H18,H26,H27, H28	
14	PAOZA	5970008276566	06090	CRN1RED	..INSULATION SLEEVING RED.....	1
					UOC:A14,A26,A27,B18,H14,H18,H26,H27,	

SECTION II			TM9-2320-280-24P			
(1)	(2)	(3)	(4)	(5)	(6)	(7)
ITEM NO	SMR CODE	NSN	CAGEC	PART NUMBER	DESCRIPTION AND USABLE ON CODES(UOC)	QTY
15	PAOZZ	5940011704956	19207	8689221	H28 .. TERMINAL, LUG.....	2
					UOC:A14, A26, A27, B18, H14, H18, H26, H27, H28	
16	MOOZZ		27647	15848	. CABLE ASSY ELECTRIC MAKE FROM WIRE, P/N M13486/1-11, 87.5 INCHES LONG.....	1
					UOC:A14, A26, A27, B18, H14, H18, H26, H27, H28	
17	PAOZZ	5970002215301	14429	RESINITEEP69C	.. INSULATION SLEEVING BLACK.....	1
					UOC:A14, A26, A27, B18, H14, H18, H26, H27, H28	
18	PAOZZ	5940005202447	19207	7064829	.. TERMINAL, LUG.....	2
					UOC:A14, A26, A27, B18, H14, H18, H26, H27, H28	
19	PAOZZ	5305012102309	27647	8548	. SCREW, TAPPING #10-24 X 3/8.....	2
					UOC:A14, A26, A27, B18, H14, H18, H26, H27, H28	
20	PAOZZ	5340009265449	96906	MS21334-28	. CLAMP, LOOP.....	2
					UOC:A14, A26, A27, B18, H14, H18, H26, H27, H28	
21	PAOZZ	5306012032637	96906	MS35764-851	. BOLT, SELF-LOCKING 7/16-14 X 1.50..	4
					UOC:A14, A26, A27, B18, H14, H18, H26, H27, H28	
22	PAOZZ	5310008094085	96906	MS27183-16	. WASHER, FLAT 7/16.....	4
					UOC:A14, A26, A27, B18, H14, H18, H26, H27, H28	
23	PAOZZ	5310009824939	96906	MS27040-13	. NUT, PLAIN, SQUARE 7/16-14.....	4
					UOC:A14, A26, A27, B18, H14, H18, H26, H27, H28	
24	PAOZZ	6150002424885	81349	M83413/8-A05BD	. LEAD ELECTRICAL.....	1
					UOC:A14, A26, A27, B18, H14, H18, H26, H27, H28	

END OF FIGURE

15 — 16 and 17

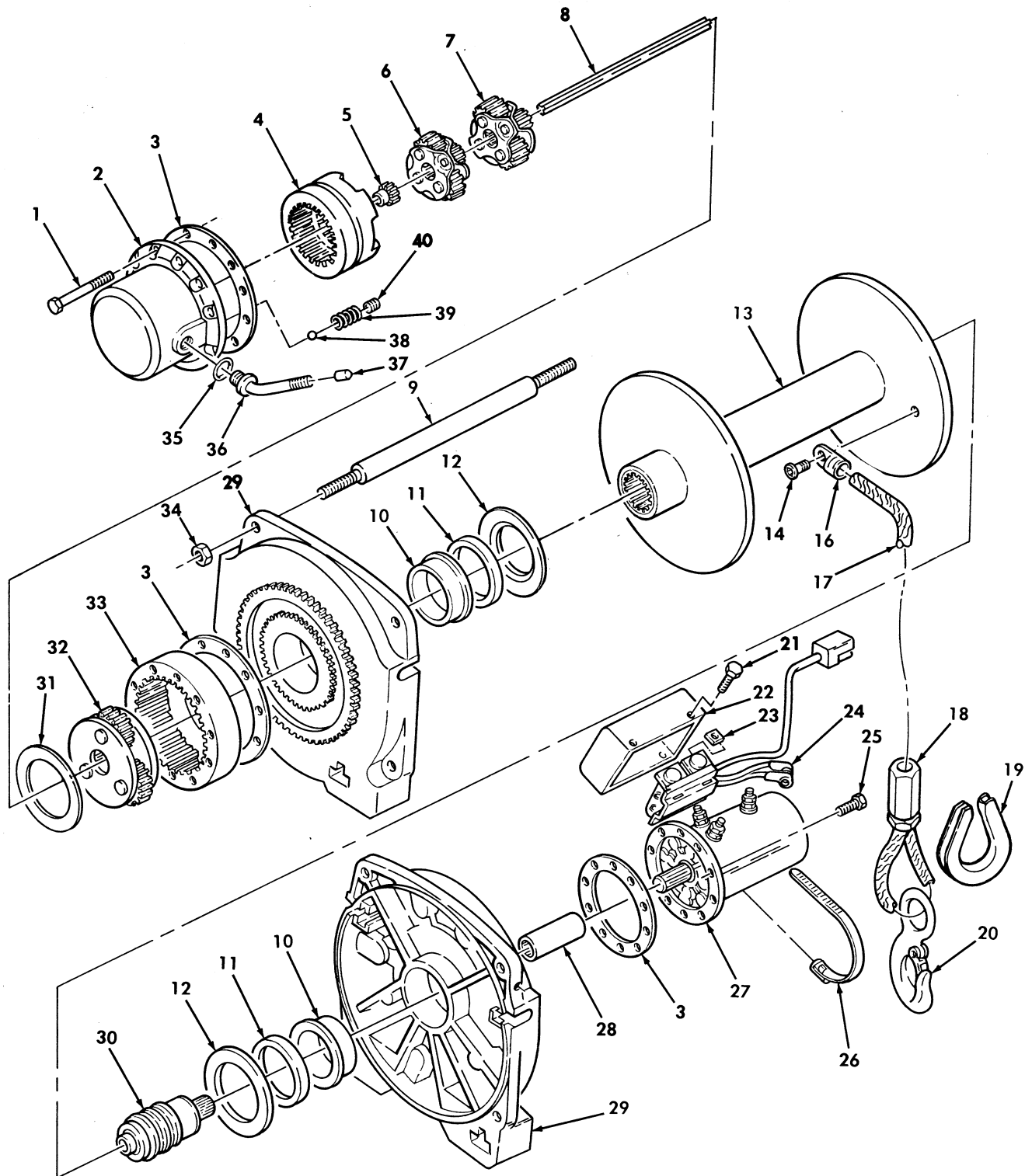

Figure 314. Winch Assembly.

SECTION II			TM9-2320-280-24P			
(1)	(2)	(3)	(4)	(5)	(6)	(7)
ITEM	SMR			PART		
NO	CODE	NSN	CAGEC	NUMBER	DESCRIPTION AND USABLE ON CODES(UC)	QTY
					GROUP 2001 HOIST,CAPSTAN,WINDLASS, CRANE OR WINCH ASSEMBLY	
					FIG. 314 WINCH ASSEMBLY	
1	PAFZZ	5305012113101	27647	13850	SCREW,CAP,SOCKET HE #10-24 X 2.25.. UOC:A14,A26,A27,B18,H14,H18,H26,H27, H28	10
2	PAHZZ	2590013299910	27647	16013	HOUSING,SHIFTER,WIN..... UOC:A14,A26,A27,B18,H14,H18,H26,H27, H28	1
3	PAFZZ	5330012110717	27647	13848	GASKET..... UOC:A14,A26,A27,B18,H14,H18,H26,H27, H28	3
4	PAFZZ	3020012094603	27647	13839	GEAR,INTERNAL..... UOC:A14,A26,A27,B18,H14,H18,H26,H27, H28	1
5	PAHZZ	3020012094606	27647	13874	GEAR,SPUR..... UOC:A14,A26,A27,B18,H14,H18,H26,H27, H28	1
6	PAFZZ	2590011857949	27647	14401	CARRIER ASSEMBLY,WI..... UOC:A14,A26,A27,B18,H14,H18,H26,H27, H28	1
7	PAFZZ	3020011857948	27647	15654	PLANETARY GEAR UNIT..... UOC:A14,A26,A27,B18,H14,H18,H26,H27, H28	1
8	PAFZZ	3040011853201	27647	15597	SHAFT,STRAIGHT..... UOC:A14,A26,A27,B18,H14,H18,H26,H27, H28	1
9	PAFZZ	3040011858011	27647	18138	SHAFT,SHOULDERED..... UOC:A14,A26,A27,B18,H14,H18,H26,H27, H28	2
10	PAFZZ	5365012161166	27647	15598	BUSHING,DRUM..... UOC:A14,A26,A27,B18,H14,H18,H26,H27, H28	2
11	PAFZZ	5330012160288	27647	15668	SEAL,PLAIN ENCASED..... UOC:A14,A26,A27,B18,H14,H18,H26,H27, H28	2
12	PAFZZ	3120013775220	27647	18545	BEARING,WASHER,THRU..... UOC:A14,A26,A27,B18,H14,H18,H26,H27, H28	2
13	PAFZZ	2590013306102	27647	15664	REEL,CABLE..... UOC:A14,A26,A27,B18,H14,H18,H26,H27, H28	1
14	PAOZZ	5305012113100	27647	16064	SCREW,CAP,SOCKET HE..... UOC:A14,A26,A27,B18,H14,H18,H26,H27, H28	1
15	PAOOO	4010013154179	27647	15667	WIRE ROPE ASSEMBLY 3/8 INCH DIA. 100 FT LONG..... UOC:A14,A26,A27,B18,H14,H18,H26,H27, H28	1
16	PAOZZ	4030012100691	27647	16464	. TERMINAL,WIRE ROPE,..... UOC:A14,A26,A27,B18,H14,H18,H26,H27,	1

SECTION II			TM9-2320-280-24P			
(1)	(2)	(3)	(4)	(5)	(6)	(7)
ITEM NO	SMR CODE	NSN	CAGEC	PART NUMBER	DESCRIPTION AND USABLE ON CODES(UC)	QTY
17	PAOZZ	4010012315075	27647	21451	H28 .ROPE,WIRE 3/8 INCH DIA. 100 FT LONG..... UOC:A14,A26,A27,B18,H14,H18,H26,H27, H28	1
18	PAOZZ	4030002378741	96906	MS16843-5	CLAMP,WIRE ROPE,THR..... UOC:A14,A26,A27,B18,H14,H18,H26,H27, H28	1
19	PAOZZ	4030012560471	75535	G-408-3/8	THIMBLE,ROPE WIRE ROPE..... UOC:A14,A26,A27,B18,H14,H18,H26,H27, H28	1
20	PAOZZ	4030012097047	27647	21781	HOOK,HOIST 7/16..... UOC:A14,A26,A27,B18,H14,H18,H26,H27, H28	1
21	PAOZZ	5305012106248	27647	8763	SCREW,MACHINE #10-24 X 3/8..... UOC:A14,A26,A27,B18,H14,H18,H26,H27, H28	3
22	PAOZZ	2590011923021	27647	15849	HOUSING,SOLENOID..... UOC:A14,A26,A27,B18,H14,H18,H26,H27, H28	1
23	PAOZZ	5310011382605	27647	8762	NUT,SHEET SPRING #10-24..... UOC:A14,A26,A27,B18,H14,H18,H26,H27, H28	3
24	PAFZZ	2590011853116	27647	15655	CONTROL ASSEMBLY,WI..... UOC:A14,A26,A27,B18,H14,H18,H26,H27, H28	1
25	PAFZZ	5305012104967	27647	980074 5553	SCREW,CAP,SOCKET HE #10-24 X 3/4... UOC:A14,A26,A27,B18,H14,H18,H26,H27, H28	10
26	PAOZZ	5342012052519	27647	6005	CLAMP..... UOC:A14,A26,A27,B18,H14,H18,H26,H27, H28	1
27	PAFZZ	6105011853187	27647	15665	MOTOR,DIRECT CURREN..... UOC:A14,A26,A27,B18,H14,H18,H26,H27, H28	1
28	PAFZZ	3040012093376	27647	16554	COUPLING ASSEMBLY,G..... UOC:A14,A26,A27,B18,H14,H18,H26,H27, H28	1
29	PAHZZ	3950013299890	27647	18136	SUPPORT,WINCH..... UOC:A14,A26,A27,B18,H14,H18,H26,H27, H28	2
30	PAHZZ	2590011857947	27647	15663	BRAKE ASSEMBLY,WINC..... UOC:A14,A26,A27,B18,H14,H18,H26,H27, H28	1
31	PAFZZ	3120013063577	27647	13826	BEARING,WASHER,THRU..... UOC:A14,A26,A27,B18,H14,H18,H26,H27, H28	1
32	PAFZZ	2590011853115	27647	26781	CARRIER ASSEMBLY,WI..... UOC:A14,A26,A27,B18,H14,H18,H26,H27, H28	1
33	PAFZZ	3020012101365	27647	16014	GEAR,INTERNAL..... UOC:A14,A26,A27,B18,H14,H18,H26,H27, H28	1

SECTION II			TM9-2320-280-24P			
(1)	(2)	(3)	(4)	(5)	(6)	(7)
ITEM NO	SMR CODE	NSN	CAGEC	PART NUMBER	DESCRIPTION AND USABLE ON CODES (UOC)	QTY
34	PAFZZ	5310012134174	27647	6779	NUT, SELF-LOCKING, HE..... UOC:A14, A26, A27, B18, H14, H18, H26, H27, H28	6
35	PAFZZ	5331009843750	02697	2-016 N674-7	O-RING..... UOC:A14, A26, A27, B18, H14, H18, H26, H27, H28	1
36	PAFZZ	3040012093409	27647	21880	LEVER, MANUAL CONTRO..... UOC:A14, A26, A27, B18, H14, H18, H26, H27, H28	1
37	PAOZZ	5355012116991	27647	15604	KNOB..... UOC:A14, A26, A27, B18, H14, H18, H26, H27, H28	1
38	PAFZZ	3110001006162	96906	MS19059-2410	BALL, BEARING..... UOC:A14, A26, A27, B18, H14, H18, H26, H27, H28	1
39	PAFZZ	5360012113163	27647	15634	SPRING, HELICAL, COMP..... UOC:A14, A26, A27, B18, H14, H18, H26, H27, H28	1
40	PAFZZ	5305014566358	24617	9416402	SETSCREW #10-24 X 1/4..... UOC:A14, A26, A27, B18, H14, H18, H26, H27, H28	1

END OF FIGURE

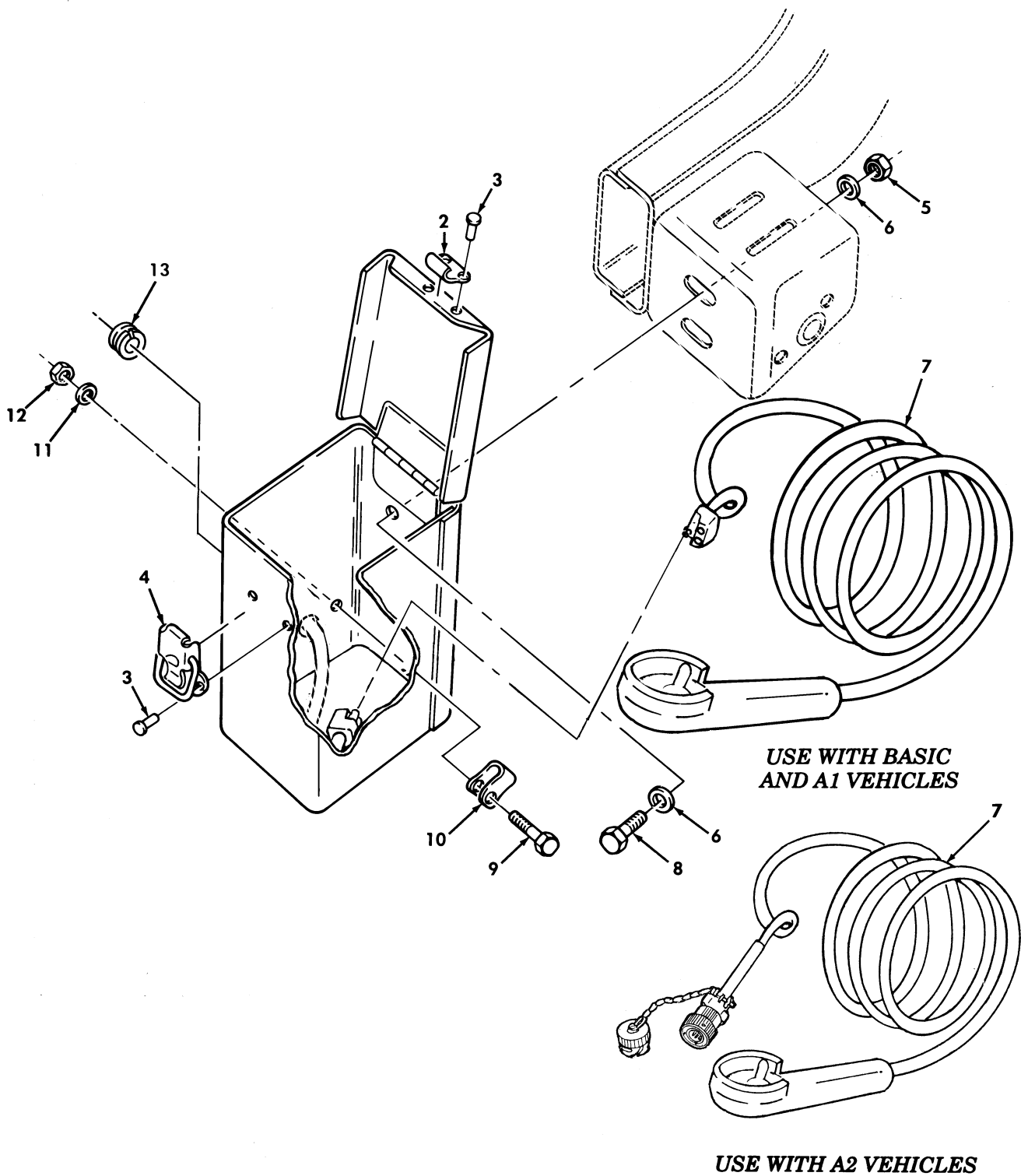
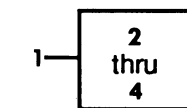
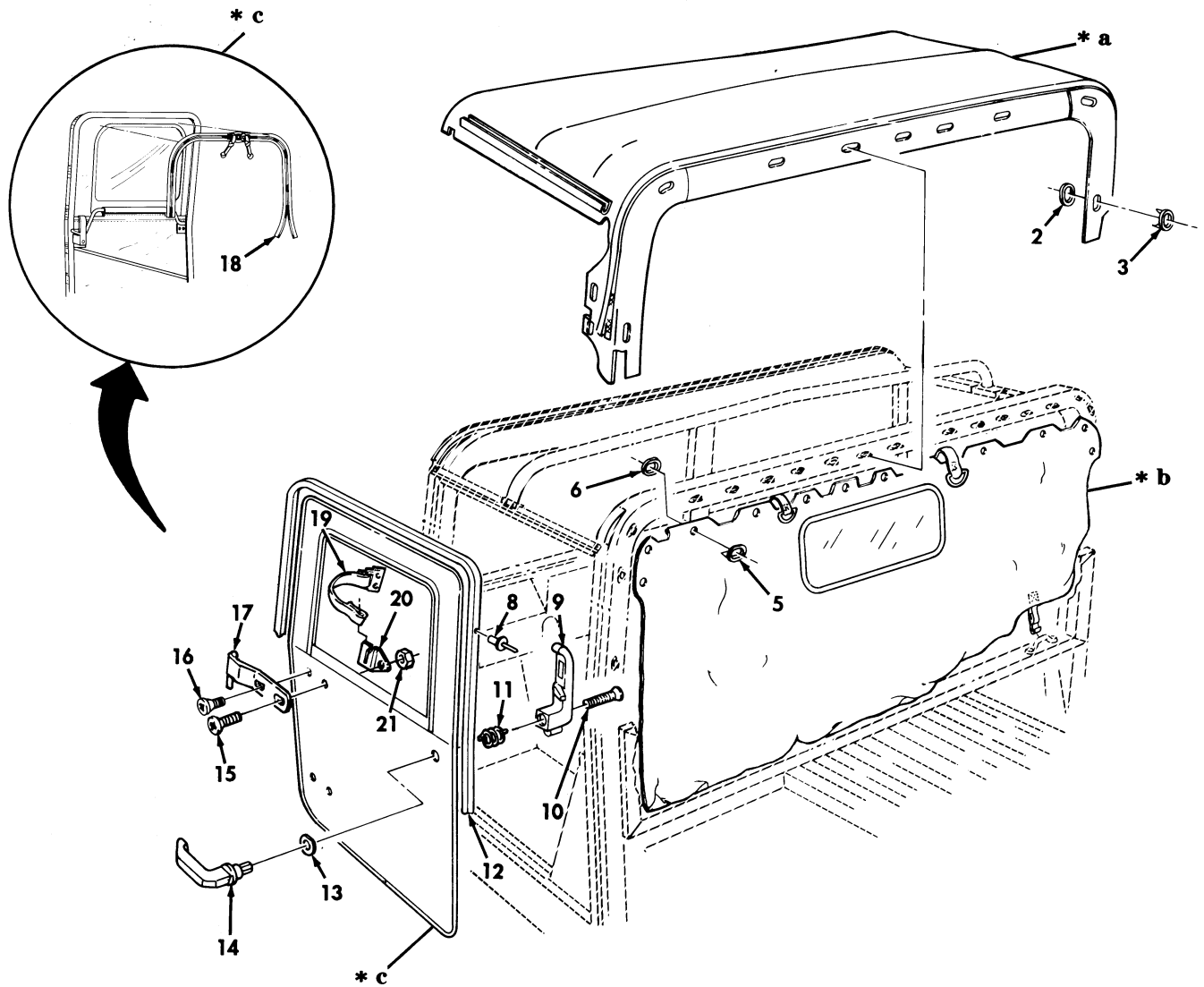
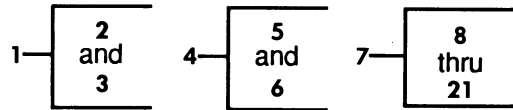

Figure 315. Winch Control, Storage Box, and Mounting Hardware.



SECTION II			TM9-2320-280-24P			
(1)	(2)	(3)	(4)	(5)	(6)	(7)
ITEM NO	SMR CODE	NSN	CAGEC	PART NUMBER	DESCRIPTION AND USABLE ON CODES(UOC)	QTY
					GROUP 2001 HOIST,CAPSTAN,WINDLASS, CRANE OR WINCH ASSEMBLY	
					FIG. 315 WINCH CONTROL,STORAGE BOX, AND MOUNTING HARDWARE	
1	PAOZZ	2540013544291	19207	12338489-1	BOX,ACCESSORIES STO USBL EFF 100, 000 AND ABOVE.....	1
					UOC:A14,A26,A27,B18,H14,H18,H26,H27, H28	
1	PAOZZ	2540012096838	19207	12338489	BOX,ACCESSORIES STO USBL EFF 1 THRU 99,999.....	1
					UOC:A14,A26,A27,B18,H14,H18,H26,H27, H28	
2	PAOZZ	5340011958057	06349	14L15-1-1XX	. STRIKE,CATCH.....	1
					UOC:A14,A26,A27,B18,H14,H18,H26,H27, H28	
3	PAOZZ	5320008990981	54402	AD42BS	.RIVET,BLIND 1/8 DIA.,.063-.125 GRIP.....	4
					UOC:A14,A26,A27,B18,H14,H18,H26,H27, H28	
4	PAOZZ	5340012096874	71286	51L3-1X1AB	. LATCH,STORAGE BOX,W.....	1
					UOC:A14,A26,A27,B18,H14,H18,H26,H27, H28	
5	PAOZZ	5310004883889	96906	MS51943-39	NUT,SELF-LOCKING,HE 1/2-13.....	2
					UOC:A14,A26,A27,B18,H14,H18,H26,H27, H28	
6	PAOZZ	5310011211703	11862	2436165	WASHER,FLAT 1/2.....	4
					UOC:A14,A26,A27,B18,H14,H18,H26,H27, H28	
7	PAOZZ	2590014481105	34623	12447171	HANDLE,MANUAL.....	1
					UOC:BVY,B15,B20,B24,B25,C17,NNN	
7	PAOZZ	2590012141566	34623	12338495	CONTROL HANDLE,WINC.....	1
					UOC:A14,A26,A27,B18,H14,H18,H26,H27, H28	
8	PAOZZ	5305000712069	80204	B1821BH050C150N	SCREW,CAP,HEXAGON H 1/2-13 X 1.50..	2
					UOC:A14,A26,A27,B18,H14,H18,H26,H27, H28	
9	PAOZZ	5305009887614	80205	MS16995-50	SCREW,CAP,SOCKET HE 1/4-20 X 3/4...	1
					UOC:A14,A26,A27,B18,H14,H18,H26,H27, H28	
10	PAOZZ	5340008091492	81348	CMDX2-3PT573036	CLAMP,LOOP.....	1
					UOC:A14,A26,A27,B18,H14,H18,H26,H27, H28	
11	PAOZZ	5310002748715	96906	MS35338-63	WASHER,LOCK 1/4.....	1
					UOC:A14,A26,A27,B18,H14,H18,H26,H27, H28	
12	PAOZZ	5310009050762	96906	MS51967-3	NUT,PLAIN,HEXAGON 1/4-20.....	1
					UOC:A14,A26,A27,B18,H14,H18,H26,H27, H28	
13	PAOZZ	5325001749332	96906	MS35489-48	GROMMET,NONMETALLIC 11/16.....	1
					UOC:A14,A26,A27,B18,H14,H18,H26,H27, H28	

END OF FIGURE



- \* a PART OF ITEM 1
- \* b PART OF ITEM 4
- \* c PART OF ITEM 7

Figure 316. Two Man Crew Soft Top Enclosure, Top Assembly, Rear Curtain, and Door Assemblies.

SECTION II			TM9-2320-280-24P			
(1)	(2)	(3)	(4)	(5)	(6)	(7)
ITEM NO	SMR CODE	NSN	CAGEC	PART NUMBER	DESCRIPTION AND USABLE ON CODES(UOC)	QTY
					GROUP 22 BODY, CHASSIS, AND HULL ACCESSORY ITEMS 2201 CONVAS, RUBBER OR PLASTIC ITEMS	
					FIG. 316 TWO MAN CREW SOFT TOP ENCLOSURE, TOP ASSEMBLY, REAR CURTAIN, AND DOOR ASSEMBLIES	
1	PAOFF	2540014504017	19207	12340736-18	COVER, FITTED, VEHICU CAMOUFLAGE PART OF KIT P/N 57K3496..... UOC:AVY, A13, A14, BVY, HVY, H13, H14, H21, H28, NNN	1
1	PAOFF	2540014504021	19207	12340736-13	COVER, FITTED, VEHICU WHITE PART OF KIT P/N 57K0162..... UOC:AVY, A13, A14, BVY, HVY, H13, H14, H21, H28, NNN	1
1	PAOFF	2540013142786	19207	12340736-7	COVER, FITTED, VEHICU PART OF KIT P/N 57K0112..... UOC:AVY, A13, A14, BVY, HVY, H13, H14, H21, H28, NNN	1
1	PAOFF	2540013306173	19207	12340736-8	COVER, FITTED, VEHICU TAN PART OF KIT P/N 57K0156..... UOC:AVY, A13, A14, BVY, HVY, H13, H14, H21, H28, NNN	1
2	PAFZZ	5325003718108	13940	BS 78505	. CLINCH PLATE, TURNBU..... UOC:AVY, A13, A14, BVY, HVY, H13, H14, H21, H28, NNN	23
3	PAFZZ	5325002818642	61864	400COMMONSENSE PE	. SOCKET, TURNBUTON F..... UOC:AVY, A13, A14, BVY, HVY, H13, H14, H21, H28, NNN	23
4	PAOFF	2540014504018	19207	12340737-6	CURTAIN ASSEMBLY, VE CAMOUFLAGE PART OF KIT P/N 57K3496..... UOC:AVY, A13, A14, BVY, HVY, H13, H14, H21, H28, NNN	1
4	PAOFF	2540014079241	34623	12340737-3	COVER, FITTED, VEHICU WHITE PART OF KIT P/N 57K0162..... UOC:AVY, A13, A14, BVY, HVY, H13, H14, H21, H28, NNN	1
4	PAOFF	2540013306171	19207	12340737-2	CURTAIN, VEHICULAR TAN PART OF KIT P/N 57K0156..... UOC:AVY, A13, A14, BVY, HVY, H13, H14, H21, H28, NNN	1
4	PAOFF	2540012008393	19207	12340737	CURTAIN, VEHICULAR GREEN PART OF KIT P/N 57K0112..... UOC:AVY, A13, A14, BVY, HVY, H13, H14, H21, H28, NNN	1
5	PAFZZ	5325002818643	13940	91-BS-78403	. SOCKET, TURNBUTON F..... UOC:AVY, A13, A14, BVY, HVY, H13, H14, H21, H28, NNN	12
6	PAFZZ	5325003718108	13940	BS 78505	. CLINCH PLATE, TURNBU..... UOC:AVY, A13, A14, BVY, HVY, H13, H14, H21, H28, NNN	12

## SECTION II TM9-2320-280-24P

(1) ITEM NO	(2) SMR CODE	(3) NSN	(4) CAGEC	(5) PART NUMBER	(6) DESCRIPTION AND USABLE ON CODES(UOC)	(7) QTY
7	PAOFF	2510014076037	34623	12340231-5	DOOR,VEHICULAR L.H.,WHITE PART OF KIT P/N 57K0162..... UOC:AVY,A13,A14,BVY,HVY,H13,H14,H21, H28,NNN	1
7	PAOFF	2510014076036	34623	12340231-6	DOOR,VEHICULAR R.H.,WHITE PART OF KIT P/N 57K0162..... UOC:AVY,A13,A14,BVY,HVY,H13,H14,H21, H28,NNN	1
7	PAOFF	2510014505480	19207	12340231-10	DOOR,VEHICULAR CAMOUFLAGE L.H. PART OF KIT P/N 57K3496..... UOC:AVY,A13,A14,BVY,HVY,H13,H14,H21, H28,NNN	1
7	PAOFF	2510014505479	19207	12340231-11	DOOR,VEHICULAR CAMOUFLAGE R.H. PART OF KIT P/N 57K3496..... UOC:AVY,A13,A14,BVY,HVY,H13,H14,H21, H28,NNN	1
7	PAOFF	2510013306174	19207	12340231-3	DOOR,VEHICULAR TAN L.H. PART OF KIT P/N 57K0156..... UOC:AVY,A13,A14,BVY,HVY,H13,H14,H21, H28,NNN	1
7	PAOFF	2510013306175	19207	12340231-4	DOOR,VEHICULAR TAN R.H. PART OF KIT P/N 57K0156..... UOC:AVY,A13,A14,BVY,HVY,H13,H14,H21, H28,NNN	1
7	PAOFF	2510011899724	34623	5581348	DOOR,VEHICULAR L.H. GREEN PART OF KIT P/N 57K0112..... UOC:AVY,A13,A14,BVY,HVY,H13,H14,H21, H28,NNN	1
7	PAOFF	2510011899725	19207	12340231-2	DOOR,VEHICULAR R.H. GREEN PART OF KIT P/N 57K0112..... UOC:AVY,A13,A14,BVY,HVY,H13,H14,H21, H28,NNN	1
8	PAOZZ	5320010232529	81349	M24243/1-A404	.RIVET,BLIND 1/8..... UOC:AVY,A13,A14,BVY,HVY,H13,H14,H21, H28,NNN	18
9	PAOZZ	2540012001994	19207	12301363-1	.HANDLE,DOOR,VEHICUL INSIDE,R.H. PART OF KIT P/N 5705618..... UOC:AVY,A13,A14,BVY,HVY,H13,H14,H21, H28,NNN	1
9	PAOZZ	2540012037721	19207	12301363-2	.HANDLE,DOOR,VEHICUL INSIDE,L.H. PART OF KIT P/N 5705619..... UOC:AVY,A13,A14,BVY,HVY,H13,H14,H21, H28,NNN	1
10	PAOZZ	5305000711327	96906	MS51960-70	.SCREW,MACHINE 10-32 X 1.25 PART OF KIT P/N 5705618 PART OF KIT P/N 5705619..... UOC:AVY,A13,A14,BVY,HVY,H13,H14,H21, H28,NNN	1
11	PAOZZ	5360013157211	19207	12356764-2	.SPRING,HELICAL,TORS R.H. PART OF KIT P/N 5705618..... UOC:AVY,A13,A14,BVY,HVY,H13,H14,H21, H28,NNN	1
11	PAOZZ	5360013157212	19207	12356764-1	.SPRING,HELICAL,TORS L.H. PART OF KIT P/N 5705619.....	1

SECTION II			TM9-2320-280-24P			
(1)	(2)	(3)	(4)	(5)	(6)	(7)
ITEM	SMR			PART		
NO	CODE	NSN	CAGEC	NUMBER	DESCRIPTION AND USABLE ON CODES(UOC)	QTY
					UOC:AVY,A13,A14,BVY,HVY,H13,H14,H21, H28,NNN	
12	MOOZZ		41024	21022103-150IN	.SEAL,NONMETALLIC SP MAKE FROM SEAL,P/N 21022103,150 INCHES LONG...	1
					UOC:AVY,A13,A14,BVY,HVY,H13,H14,H21, H28,NNN	
13	PAOZZ	5310012059056	34623	5581321	.WASHER,FLAT 5/8 PART OF KIT P/N 5705618 PART OF KIT P/N 5705619.....	1
					UOC:AVY,A13,A14,BVY,HVY,H13,H14,H21, H28,NNN	
14	PAOZZ	2540012001995	19207	12301365	.HANDLE,DOOR,VEHICUL PART OF KIT P/N 5705618 PART OF KIT P/N 5705619.....	1
					UOC:AVY,A13,A14,BVY,HVY,H13,H14,H21, H28,NNN	
15	PAOZZ	5305009881725	96906	MS35206-281	.SCREW,MACHINE 1/4-20 X 3/4.....	1
					UOC:AVY,A13,A14,BVY,HVY,H13,H14,H21, H28,NNN	
16	PAOZZ	5305000711315	96906	MS51957-79	.SCREW,MACHINE 1/4-20 X 1/2.....	3
					UOC:AVY,A13,A14,BVY,HVY,H13,H14,H21, H28,NNN	
17	PAOZZ	5340012059021	19207	12340193-1	.LEAF,BUTT HINGE L.H.....	2
					UOC:AVY,A13,A14,BVY,HVY,H13,H14,H21, H28,NNN	
17	PFOZZ	5340012059022	19207	12340193-2	.LEAF,BUTT HINGE R.H.....	2
					UOC:AVY,A13,A14,BVY,HVY,H13,H14,H21, H28,NNN	
18	PAFZZ	5325013571080	19207	12340212-3	.FASTENER,SLIDE,INTE.....	1
					UOC:AVY,A13,A14,BVY,HVY,H13,H14,H21, H28,NNN	
19	PAOZZ	5340012547189	19207	12340201	.LOOP,STRAP FASTENER.....	1
					UOC:AVY,A13,A14,BVY,HVY,H13,H14,H21, H28,NNN	
20	PAOZZ	5340012569318	41024	41256040	.LOOP,STRAP FASTENER L.H.....	1
					UOC:AVY,A13,A14,BVY,HVY,H13,H14,H21, H28,NNN	
20	PAOZZ	5340012559919	34623	5595217	.LOOP,STRAP FASTENER R.H.....	1
					UOC:AVY,A13,A14,BVY,HVY,H13,H14,H21, H28,NNN	
21	PAOZZ	5310000614650	96906	MS51943-31	.NUT,SELF-LOCKING,HE 1/4-20.....	4
					UOC:AVY,A13,A14,BVY,HVY,H13,H14,H21, H28,NNN	

END OF FIGURE

Section II.

TM 9-2320-280-24P-1

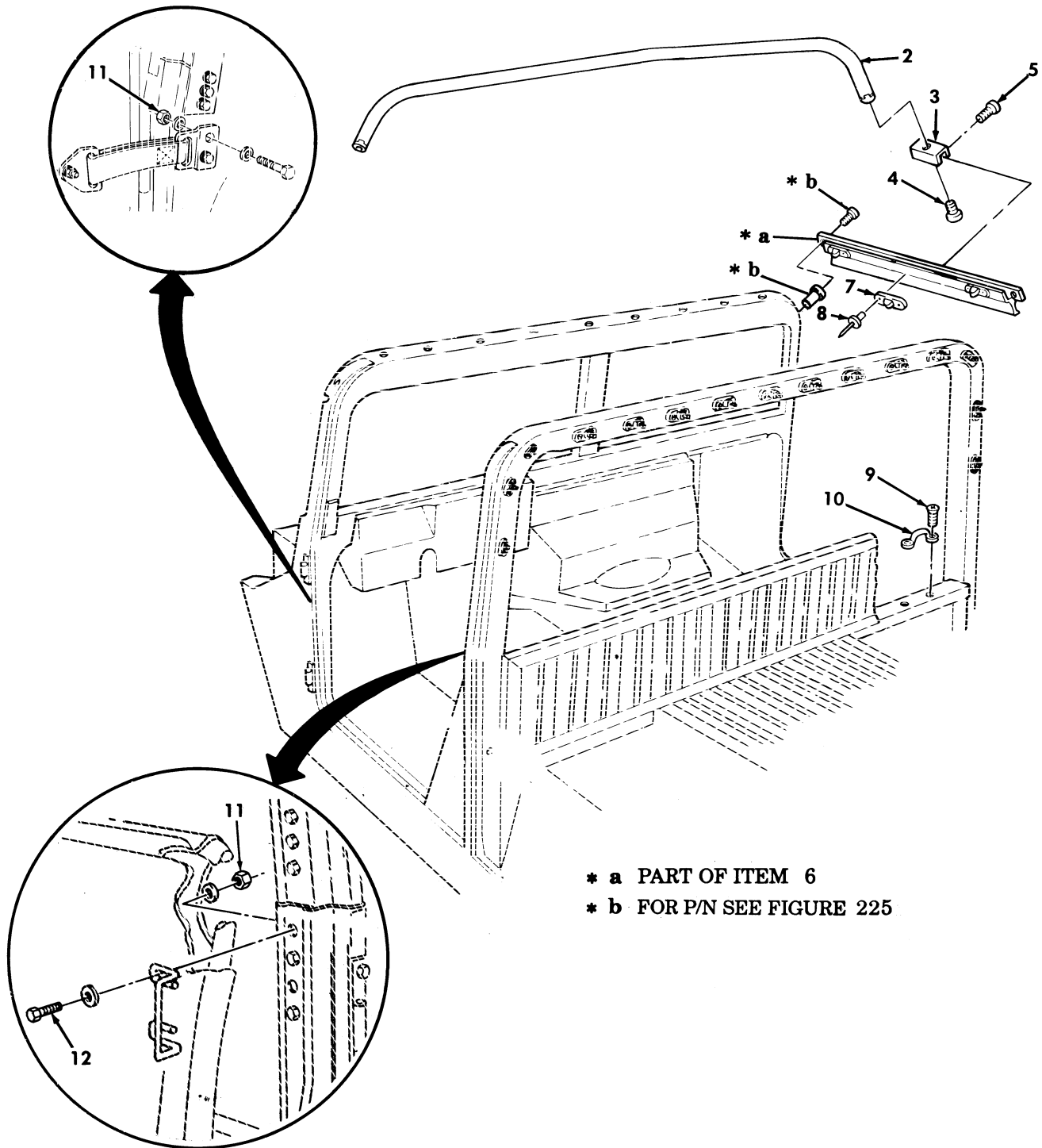
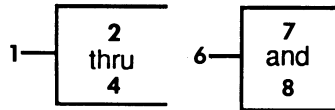

\* a PART OF ITEM 6  
\* b FOR P/N SEE FIGURE 225

Figure 317. Two Man Crew Soft Top Enclosure, Bow, and Mounting Components.

SECTION II			TM9-2320-280-24P			
(1)	(2)	(3)	(4)	(5)	(6)	(7)
ITEM	SMR			PART		
NO	CODE	NSN	CAGEC	NUMBER	DESCRIPTION AND USABLE ON CODES(UCO)	QTY
					GROUP 2201 CANVAS,RUBBER OR PLASTIC ITEMS	
					FIG. 317 TWO MAN CREW SOFT TOP ENCLOSURE,BOW,AND MOUNTING COMPONENTS	
1	PAOZZ	2540011996759	19207	12340682	BOW,VEHICULAR TOP GREEN,(PAINT TAN OR WHITE IF REQUIRED) PART OF KIT P/N 57K0112 PART OF KIT P/N 57K0156 PART OF KIT P/N 57K0162 PART OF KIT P/N 57K3496.....	1
					UCO:AVY,A13,A14,BVY,HVY,H13,H14,H21,H28,NNN	
2	PAOZZ	2540012064115	19207	12340713	.BOW,VEHICULAR TOP.....	1
					UCO:AVY,A13,A14,BVY,HVY,H13,H14,H21,H28,NNN	
3	PFOZZ	5340012043862	19207	12340239	.STRAP,RETAINING.....	2
					UCO:AVY,A13,A14,BVY,HVY,H13,H14,H21,H28,NNN	
4	PAOZZ	5305012038346	34623	5581439	.SCREW,CAP,SOCKET HE 1/4-20 X 3/8..	2
					UCO:AVY,A13,A14,BVY,HVY,H13,H14,H21,H28,NNN	
5	PAOZZ	5305009897434	96906	MS35207-263	SCREW,MACHINE #10-32 X 1/2 PART OF KIT P/N 57K0112 PART OF KIT P/N 57K0156 PART OF KIT P/N 57K0162 PART OF KIT P/N 57K3496.....	4
					UCO:AVY,A13,A14,BVY,HVY,H13,H14,H21,H28,NNN	
6	PFOZZ	2590011982895	34623	5581371	HANDRAIL,VEHICULAR L.H.,GREEN,(PAINT TAN OR WHITE IF REQUIRED) PART OF KIT P/N 57K0112 PART OF KIT P/N 57K0156 PART OF KIT P/N 57K0162 PART OF KIT P/N 57K3496.....	1
					UCO:AVY,A13,A14,BVY,HVY,H13,H14,H21,H28,NNN	
6	PFOZZ	2590011974898	34623	5581372	HANDRAIL,VEHICULAR R.H.,GREEN,(PAINT TAN OR WHITE IF REQUIRED) PART OF KIT P/N 57K0112 PART OF KIT P/N 57K0156 PART OF KIT P/N 57K0162 PART OF KIT P/N 57K3496.....	1
					UCO:AVY,A13,A14,BVY,HVY,H13,H14,H21,H28,NNN	
7	PAOZZ	5325008235999	13940	XB78323-05001	.STUD,TURNBUTTON FAS L.H. AND R.H..	6
					UCO:AVY,A13,A14,BVY,HVY,H13,H14,H21,H28,NNN	
8	PAOZZ	5320000835009	81349	M24243/1-A403	.RIVET,BLIND 1/8,L.H. AND R.H.....	12
					UCO:AVY,A13,A14,BVY,HVY,H13,H14,H21,H28,NNN	
9	PAOZZ	5305011993371	16941	PL25J02P12	SCREW,CAP,SOCKET HE #10-32 X 3/4...	4
					UCO:AVY,A13,A14,BVY,HVY,H13,H14,H21,H28,NNN	
10	PAOZZ	5340011978673	19207	12338839-4	HANDLE,BOW REAR.....	2

SECTION II			TM9-2320-280-24P			
(1)	(2)	(3)	(4)	(5)	(6)	(7)
ITEM NO	SMR CODE	NSN	CAGEC	PART NUMBER	DESCRIPTION AND USABLE ON CODES(UCO)	QTY
11	PAOZZ	5310002416658	96906	MS51943-34	UOC:AVY,A13,A14,BVY,HVY,H13,H14,H21,H28,NNN NUT,SELF-LOCKING,HE 5/16-24 PART OF KIT P/N 57K0112 PART OF KIT P/N 57K0156 PART OF KIT P/N 57K0162 PART OF KIT P/N 57K3496..... UOC:AVY,A13,A14,BVY,HVY,H13,H14,H21,H28,NNN	8
12	PAOZZ	5306001822027	88044	AN5H10A	BOLT,MACHINE PART OF KIT P/N 57K0112 PART OF KIT P/N 57K0156 PART OF KIT P/N 57K0162 PART OF KIT P/N 57K3496. UOC:AVY,A13,A14,BVY,HVY,H13,H14,H21,H28,NNN	4
KIT	PAOZZ	2540013160892	19207	57K0112	COVER,FITTED,VEHICU GREEN..... UOC:AVY,A13,A14,BVY,HVY,H13,H14,H21,H28,NNN BOLT,MACHINE ( 4) 317-12 BOW,VEHICULAR TOP ( 1) 317-1 COVER,FITTED,VEHICU( 1) 316-1 CURTAIN ASSEMBLY,VE( 1) 316-4 DOOR,VEHICULAR ( 1) 316-7 DOOR,VEHICULAR ( 1) 316-7 NUT,SELF-LOCKING,HE( 8) 317-11 RAIL ASSEMBLY,HAND ( 1) 317-6 RAIL ASSEMBLY,HAND ( 1) 317-6 SCREW,MACHINE ( 4) 317-5	1
KIT	PDOZZ	2540013298072	19207	57K0156	PARTS KIT,SOFT TOP TAN..... UOC:AVY,A13,A14,BVY,HVY,H13,H14,H21,H28,NNN BOLT,MACHINE ( 4) 317-12 BOW,VEHICULAR TOP ( 1) 317-1 COVER,FITTED,VEHICU( 1) 316-1 CURTAIN ASSEMBLY,VE( 1) 316-4 DOOR,VEHICULAR ( 1) 316-7 DOOR,VEHICULAR ( 1) 316-7 NUT,SELF-LOCKING,HE( 8) 317-11 RAIL ASSEMBLY,HAND ( 1) 317-6 RAIL ASSEMBLY,HAND ( 1) 317-6 SCREW,MACHINE ( 4) 317-5	1
KIT	PDOZZ	2540013994692	19207	57K0162	COVER,FITTED,VEHICU WHITE..... UOC:AVY,A13,A14,BVY,HVY,H13,H14,H21,H28,NNN BOLT,MACHINE ( 4) 317-12 BOW,VEHICULAR TOP ( 1) 317-1 COVER,FITTED,VEHICU( 1) 316-1 CURTAIN ASSEMBLY,VE( 1) 316-4 DOOR,VEHICULAR ( 1) 316-7 DOOR,VEHICULAR ( 1) 316-7 NUT,SELF-LOCKING,HE( 8) 317-11 RAIL ASSEMBLY,HAND ( 1) 317-6 RAIL ASSEMBLY,HAND ( 1) 317-6 SCREW,MACHINE ( 4) 317-5	1
KIT	PAOZZ	2540014348600	19207	57K3496	COVER,FITTED,VEHICU CAMOUFLAGE.....	1



SECTION II			TM9-2320-280-24P			
(1)	(2)	(3)	(4)	(5)	(6)	(7)
ITEM	SMR			PART		
NO	CODE	NSN	CAGEC	NUMBER	DESCRIPTION AND USABLE ON CODES(UC)	QTY

UC:AVY,A13,A14,BVY,HVY,H13,H14,H21,  
H28,NNN

	BOLT,MACHINE	(	4)	317-12		
	BOW,VEHICULAR TOP	(	1)	317-1		
	COVER,FITTED,VEHICU	(	1)	316-1		
	CURTAIN ASSEMBLY,VE	(	1)	316-4		
	DOOR,VEHICULAR	(	1)	316-7		
	DOOR,VEHICULAR	(	1)	316-7		
	NUT,SELF-LOCKING,HE	(	8)	317-11		
	RAIL ASSEMBLY,HAND	(	1)	317-6		
	RAIL ASSEMBLY,HAND	(	1)	317-6		
	SCREW,MACHINE	(	4)	317-5		

END OF FIGURE

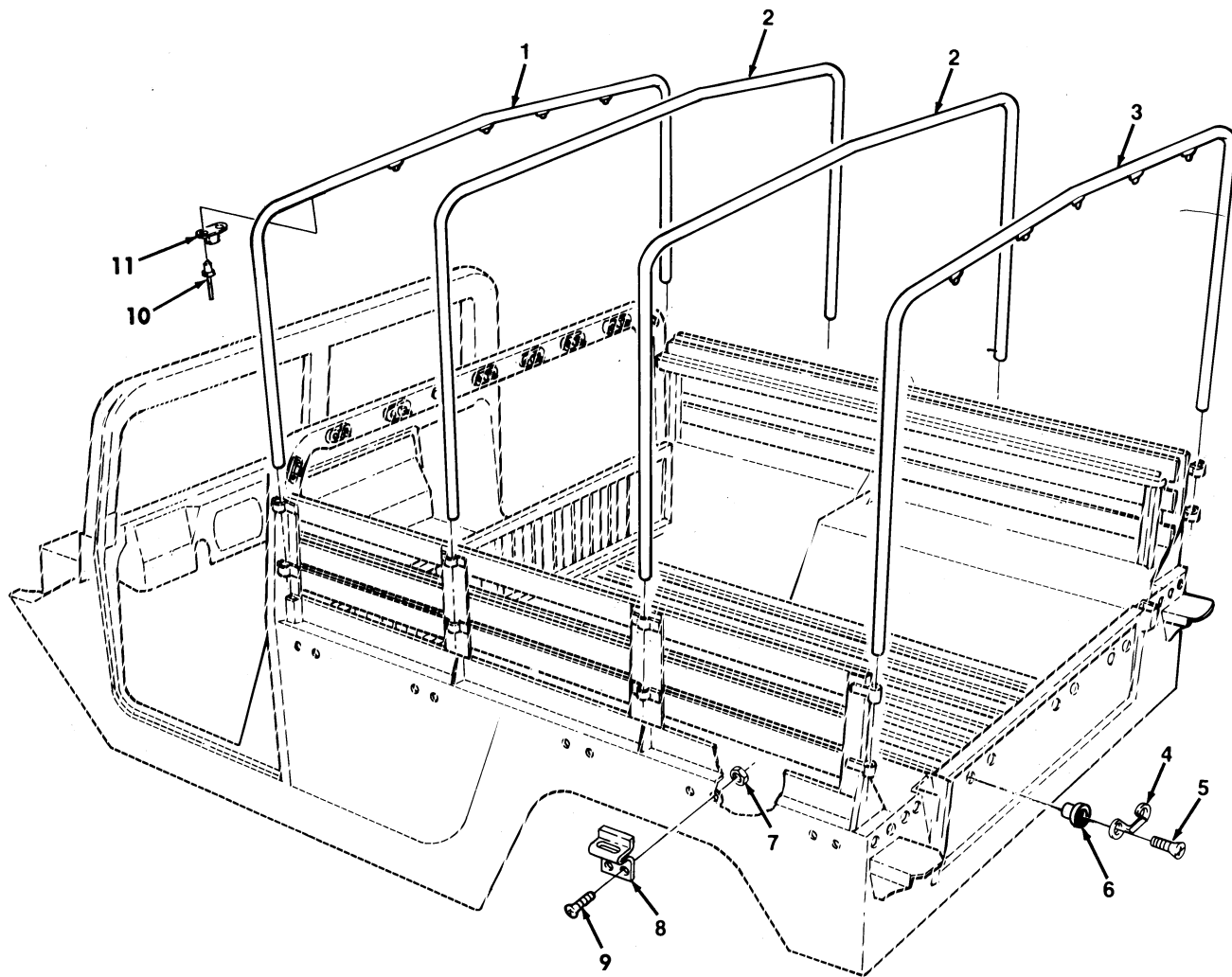
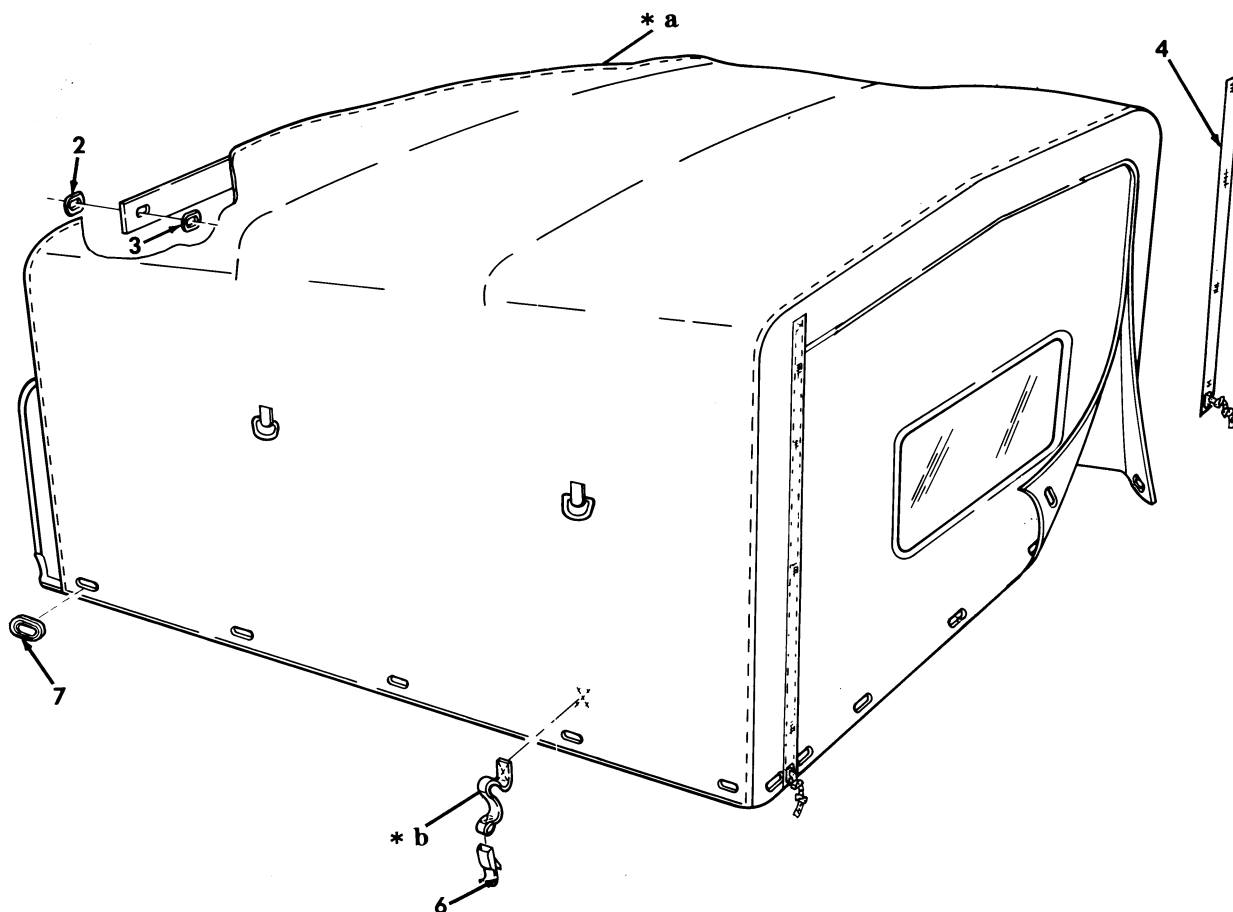
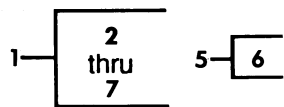

Figure 318. Troop Area Soft Top Enclosure, Bows, and Mounting Components.

SECTION II			TM9-2320-280-24P			
(1)	(2)	(3)	(4)	(5)	(6)	(7)
ITEM	SMR			PART		
NO	CODE	NSN	CAGEC	NUMBER	DESCRIPTION AND USABLE ON CODES(UOC)	QTY
GROUP 2201 CANVAS,RUBBER OR PLASTIC ITEMS						
FIG. 318 TROOP AREA SOFT TOP ENCLOSURE,BOWS,AND MOUNTING COMPONENTS						
1	PFOZZ	2540012006611	19207	12340764-2	BOW,VEHICULAR TOP FRONT,GREEN, (PAINT TAN OR WHITE IF REQUIRED)PART OF KIT P/N 12340744 PART OF KIT P/N 57K0160 PART OF KIT P/N 57K3500 PART OF KIT P/N 57K0157.....	1
2	PFOZZ	2540011996760	19207	12340747	UOC:AVY,A13,A14,BVY,HVY,H13,H14,NNN BOW,VEHICULAR TOP GREEN,(PAINT TAN OR WHITE IF REQUIRED)PART OF KIT P/N 12340744 PART OF KIT P/N 57K0160 PART OF KIT P/N 57K3500 PART OF KIT P/N 57K0157.....	2
3	PFOZZ	2540011996761	19207	12340764-1	UOC:AVY,A13,A14,BVY,HVY,H13,H14,NNN BOW,VEHICULAR TOP GREEN,(PAINT TAN OR WHITE IF REQUIRED)PART OF KIT P/N 12340744 PART OF KIT P/N 57K0160 PART OF KIT P/N 57K3500 PART OF KIT P/N 57K0157.....	1
4	PAOZZ	5340013145957	19207	12338839-1	UOC:AVY,A13,A14,BVY,HVY,H13,H14,NNN LOOP,STRAP FASTENER PART OF KIT P/N 57K3499.....	3
5	PAOZZ	5305011993371	16941	PL25J02P12	UOC:AVY,A13,A14,BVY,HVY,H13,H14,NNN SCREW,CAP,SOCKET HE #10-32 X 3/4...	6
6	PFOZZ	5310011981723	19207	12339998-14	UOC:AVY,A13,A14,BVY,HVY,H13,H14,NNN NUT,PLAIN,BLIND RIV #10-32.....	6
7	PAOZZ	5310001249265	72582	271169	UOC:AVY,A13,A14,BVY,HVY,H13,H14,NNN NUT,PLAIN,ASSEMBLED #10-32.....	20
8	PAOZZ	5340012609027	34623	5593625	UOC:AVY,A13,A14,BVY,HVY,H13,H14,NNN LOOP,STRAP FASTENER.....	10
9	PAOZZ	5305014077713	24617	160052	UOC:AVY,A13,A14,BVY,HVY,H13,H14,NNN SCREW,MACHINE #10-32 X 5/8.....	20
10	PAOZZ	5320010232529	81349	M24243/1-A404	UOC:AVY,A13,A14,BVY,HVY,H13,H14,NNN RIVET,BLIND.....	20
11	PAOZZ		21450	549220	UOC:AVY,A13,A14,BVY,HVY,H13,H14,NNN FASTENER,TURNBUTON.....	10

END OF FIGURE



- \* a PART OF ITEM 1
- \* b PART OF ITEM 5

Figure 319. Troop Area Soft Top Enclosure.

SECTION II			TM9-2320-280-24P			
(1)	(2)	(3)	(4)	(5)	(6)	(7)
ITEM NO	SMR CODE	NSN	CAGEC	PART NUMBER	DESCRIPTION AND USABLE ON CODES(UCO)	QTY
					GROUP 2201 CANVAS,RUBBER OR PLASTIC ITEMS	
					FIG. 319 TROOP AREA SOFT TOP ENCLOSURE	
1	PAOFF	2540011893457	19207	12340761	COVER,FITTED,VEHICU GREEN PART OF KIT P/N 12340744.....	1
1	PAOFF	2540014504015	19207	12340761-9	UCO:AVY,A13,A14,BVY,HVY,H13,H14,NNN COVER,FITTED,VEHICU CAMOUFLAGE PART OF KIT P/N 57K3500.....	1
1	PAOFF	2540014507686	19207	12340761-3	UCO:AVY,A13,A14,BVY,HVY,H13,H14,NNN COVER,FITTED,VEHICU WHITE PART OF KIT P/N 57K0160.....	1
1	PAOFF	2540013306169	19207	12340761-2	UCO:AVY,A13,A14,BVY,HVY,H13,H14,NNN COVER,FITTED,VEHICU TAN PART OF KIT P/N 57K0157.....	1
2	PAFZZ	5325002818643	13940	91-BS-78403	UCO:AVY,A13,A14,BVY,HVY,H13,H14,NNN .SOCKET,TURNBUTTON F.....	19
3	PAFZZ	5325003718108	13940	BS 78505	UCO:AVY,A13,A14,BVY,HVY,H13,H14,NNN .CLINCH PLATE,TURNBU.....	19
4	PAFZZ	2590013162581	38506	52252	UCO:AVY,A13,A14,BVY,HVY,H13,H14,NNN .MODIFICATION KIT,VE.....	2
5	PAFZZ	5340011992206	34623	5581505	UCO:AVY,A13,A14,BVY,HVY,H13,H14,NNN .STRAP,WEBBING.....	17
6	PAOZZ	5340012036542	31272	44702-10	UCO:AVY,A13,A14,BVY,HVY,H13,H14,NNN ..BUCKLE.....	1
7	PAOZZ	5325014374175	19207	12340526	UCO:AVY,A13,A14,BVY,HVY,H13,H14,NNN .GROMMET,NONMETALLIC.....	17
KIT	PAOZZ	2540014504022	19207	57K0160	COVER,FITTED,VEHICU WHITE.....	1
					UCO:AVY,A13,A14,BVY,HVY,H13,H14,NNN BOW,VEHICULAR TOP ( 1) 318-1	
					BOW,VEHICULAR TOP ( 2) 318-2	
					BOW,VEHICULAR TOP ( 1) 318-3	
					COVER,FITTED,VEHICU( 1) 319-1	
KIT	PAOZZ	2540014348602	19207	57K3500	COVER,FITTED,VEHICU STANDARD CAMOUFLAGE,TROOP AREA ENCLOSURE.....	1
					UCO:AVY,A13,A14,BVY,HVY,H13,H14,NNN BOW,VEHICULAR TOP ( 1) 318-1	
					BOW,VEHICULAR TOP ( 2) 318-2	
					BOW,VEHICULAR TOP ( 1) 318-3	
					COVER,FITTED,VEHICU( 1) 319-1	
KIT	PDOZZ	2540013298073	19207	57K0157	PARTS KIT,SOFT TOP ASSY, TROOP AREA, TAN.....	1
					UCO:AVY,A13,A14,BVY,HVY,H13,H14,NNN BOW,VEHICULAR TOP ( 1) 318-1	
					BOW,VEHICULAR TOP ( 2) 318-2	
					BOW,VEHICULAR TOP ( 1) 318-3	
					COVER,FITTED,VEHICU( 1) 319-1	
KIT	PDOZZ	2540011910973	19207	12340744	PARTS KIT,SOFT TOP ASSY, TROOP AREA, GREEN.....	1
					UCO:AVY,A13,A14,BVY,HVY,H13,H14,NNN	

SECTION II			TM9-2320-280-24P			
(1)	(2)	(3)	(4)	(5)	(6)	(7)
ITEM	SMR			PART		
NO	CODE	NSN	CAGEC	NUMBER	DESCRIPTION AND USABLE ON	CODES (UOC) QTY
					BOW,VEHICULAR TOP	( 1) 318-1
					BOW,VEHICULAR TOP	( 2) 318-2
					BOW,VEHICULAR TOP	( 1) 318-3
					COVER,FITTED,VEHICU	( 1) 319-1

END OF FIGURE

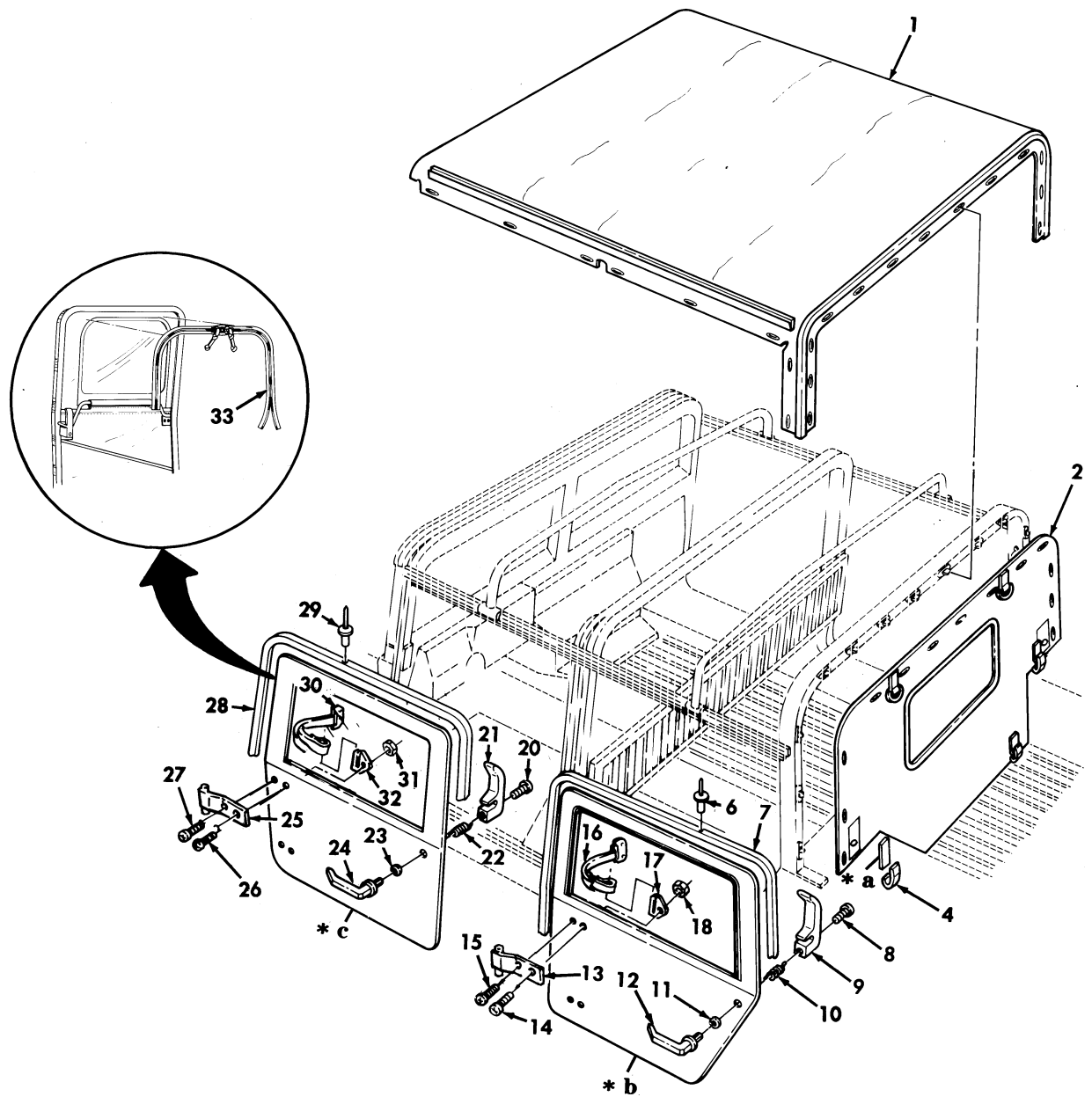
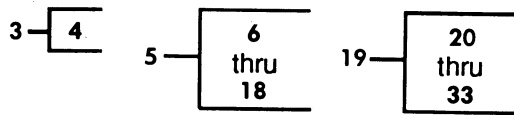

- \* a PART OF ITEM 3
- \* b PART OF ITEM 5
- \* c PART OF ITEM 19

Figure 320. Four Man Crew Soft Top Enclosure, Top Assembly, Rear Curtain, and Door Assemblies.

SECTION II			TM9-2320-280-24P			
(1)	(2)	(3)	(4)	(5)	(6)	(7)
ITEM NO	SMR CODE	NSN	CAGEC	PART NUMBER	DESCRIPTION AND USABLE ON CODES(UCO)	QTY
					GROUP 2201 CANVAS,RUBBER OR PLASTIC ITEMS	
					FIG. 320 FOUR MAN CREW SOFT TOP ENCLOSURE, TOP ASSEMBLY, REAR CURTAIN, AND DOOR ASSEMBLIES	
1	PAOFF	2540011893706	19207	12340676	TOP ASSEMBLY, TRUCK GREEN PART OF KIT P/N 57K0123.....	1
					UOC:A13,A14,BVY,H13,H14,NNN	
1	PAOFF	2540013306177	19207	12340676-11	TOP ASSEMBLY, TRUCK TAN PART OF KIT P/N 57K0155.....	1
					UOC:A13,A14,BVY,H13,H14,NNN	
1	PAOFF	2540014504019	19207	12340676-31	TOP ASSEMBLY TRUCK CAMOUFLAGE PART OF KIT P/N 57K3501.....	1
					UOC:A13,A14,BVY,H13,H14,NNN	
1	PAOFF	2540014122661	19207	12340676-21	TOP ASSEMBLY TRUCK WHITE PART OF KIT P/N 57K0161.....	1
					UOC:A13,A14,BVY,H13,H14,NNN	
2	PAOFF	2540013142782	19207	12342475	CURTAIN, VEHICULAR GREEN PART OF KIT P/N 57K0123.....	1
					UOC:A13,A14,BVY,H13,H14,NNN	
2	PAOFF	2540014505477	19207	12342475-6	CURTAIN, VEHICULAR CAMOUFLAGE PART OF KIT P/N 57K3501.....	1
					UOC:A13,A14,BVY,H13,H14,NNN	
2	PAOFF	2540013306172	19207	12342475-1	CURTAIN, VEHICULAR TAN PART OF KIT P/N 57K0155.....	1
					UOC:A13,A14,BVY,H13,H14,NNN	
2	PAOFF	2540014131356	19207	12342475-2	CURTAIN, VEHICULAR WHITE PART OF KIT P/N 57K0161.....	1
					UOC:A13,A14,BVY,H13,H14,NNN	
3	PFOZZ	5340011992206	34623	5581505	STRAP, WEBBING.....	4
					UOC:A13,A14,BVY,H13,H14,NNN	
4	PAOZZ	5340012036542	31272	44702-10	.BUCKLE.....	1
					UOC:A13,A14,BVY,H13,H14,NNN	
5	PAOFF	2510011893460	19207	12340245-1	DOOR ASSEMBLY, VEHIC L.H., GREEN PART OF KIT P/N 57K0123.....	1
					UOC:A13,A14,BVY,H13,H14,NNN	
5	PAOFF	2510011893459	19207	12340245-2	DOOR ASSEMBLY, VEHIC R.H., GREEN PART OF KIT P/N 57K0123.....	1
					UOC:A13,A14,BVY,H13,H14,NNN	
5	PAOFF	2510013306176	19207	12340245-3	DOOR ASSEMBLY, VEHIC R.H., TAN PART OF KIT P/N 57K0155.....	1
					UOC:A13,A14,BVY,H13,H14,NNN	
5	PAOFF	2510013306576	19207	12340245-4	DOOR ASSEMBLY, VEHIC L.H., TAN PART OF KIT P/N 57K0155.....	1
					UOC:A13,A14,BVY,H13,H14,NNN	
5	PAOFF	2510014126761	19207	12340245-5	DOOR ASSEMBLY, VEHIC L.H., WHITE PART OF KIT P/N 57K0161.....	1
					UOC:A13,A14,BVY,H13,H14,NNN	
5	PAOFF	2510014138872	19207	12340245-6	DOOR ASSEMBLY, VEHIC R.H., WHITE PART OF KIT P/N 57K0161.....	1
					UOC:AVY,A13,A14,BVY,HVY,H13,H14	



SECTION II		TM9-2320-280-24P					
(1)	(2)	(3)	(4)	(5)	(6)	(7)	(7)
ITEM	SMR			PART			
NO	CODE	NSN	CAGEC	NUMBER	DESCRIPTION AND USABLE ON CODES(UC)	QTY	
5	PAOFF	2510014505482	19207	12340245-7	DOOR ASSEMBLY,VEHIC R.H.,CAMOUFLAGE PART OF KIT P/N 57K3501.....	1	
					UC:A13,A14,BVY,H13,H14,NNN		
5	PAOFF	2510014505483	19207	12340245-8	DOOR ASSEMBLY,VEHIC L.H.,CAMOUFLAGE PART OF KIT P/N 57K3501.....	1	
					UC:A13,A14,BVY,H13,H14,NNN		
6	PAOZZ	5320010232529	81349	M24243/1A404	.RIVET,BLIND 1/8.....	18	
					UC:A13,A14,BVY,H13,H14,NNN		
7	MOOZZ		41024	21022013-150IN.	.SEAL,NONMETALLIC SP MAKE FROM SEAL,P/N 21022103,150 INCHES LONG...	1	
					UC:A13,A14,BVY,H13,H14,NNN		
8	PAOZZ	5305000711327	96906	MS51960-70	.SCREW,MACHINE #10-32 X 1.25 PART OF KIT P/N 5705618 PART OF KIT P/N 5705619.....	1	
					UC:A13,A14,BVY,H13,H14,NNN		
9	PAOZZ	2540012001994	34623	5581320	.HANDLE,DOOR,VEHICUL REAR,L.H. PART OF KIT P/N 5705619.....	1	
					UC:A13,A14,BVY,H13,H14,NNN		
9	PAOZZ	2540012037721	19207	12301363-2	.HANDLE,DOOR,VEHICUL REAR,R.H. PART OF KIT P/N 5705618.....	1	
					UC:A13,A14,BVY,H13,H14,NNN		
10	PAOZZ	5360013157212	19207	12356764-1	.SPRING,HELICAL,TORS L.H. PART OF KIT P/N 5705619.....	1	
					UC:A13,A14,BVY,H13,H14,NNN		
10	PAOZZ	5360013157211	19207	12356764-2	.SPRING,HELICAL,TORS R.H. PART OF KIT P/N 5705618 PART OF KIT P/N 5705619.....	1	
					UC:A13,A14,BVY,H13,H14,NNN		
11	PAOZZ	5310012059056	34623	5581321	.WASHER,FLAT PART OF KIT P/N 5705618 PART OF KIT P/N 5705619.....	1	
					UC:A13,A14,BVY,H13,H14,NNN		
12	PAOZZ	2540012001995	19207	12301365	.HANDLE,DOOR,VEHICUL PART OF KIT P/N 5705618 PART OF KIT P/N 5705619....	1	
					UC:A13,A14,BVY,H13,H14,NNN		
13	PAOZZ	5340012059021	19207	12340193-1	.LEAF,BUTT HINGE REAR, L.H.....	2	
					UC:A13,A14,BVY,H13,H14,NNN		
13	PFOZZ	5340012059022	19207	12340193-2	.LEAF,BUTT HINGE REAR, R.H.....	2	
					UC:A13,A14,BVY,H13,H14,NNN		
14	PAOZZ	5305009881725	96906	MS35206-281	.SCREW,MACHINE 1/4-20 X 3/4.....	1	
					UC:A13,A14,BVY,H13,H14,NNN		
15	PAOZZ	5305000711315	96906	MS51957-79	.SCREW,MACHINE 1/4-20 X 1/2.....	3	
					UC:A13,A14,BVY,H13,H14,NNN		
16	PAOZZ	5340012547189	19207	12340201	.LOOP,STRAP FASTENER.....	1	
					UC:A13,A14,BVY,H13,H14,NNN		
17	PAOZZ	5340012569318	41024	41256040	.LOOP,STRAP FASTENER L.H.....	1	
					UC:A13,A14,BVY,H13,H14,NNN		
17	PAOZZ	5340012559919	34623	5595217	.LOOP,STRAP FASTENER R.H.....	1	
					UC:A13,A14,BVY,H13,H14,NNN		
18	PAOZZ	5310011520598	24617	271172	.NUT,SELF-LOCKING,AS 1/4 X 20.....	4	
					UC:A13,A14,BVY,H13,H14,NNN		
19	PAOFF	2510011899724	34623	5581348	DOOR ASSEMBLY,VEHIC GREEN,FRONT, L.H. PART OF KIT P/N 57K0123.....	1	
					UC:A13,A14,BVY,H13,H14,NNN		

SECTION II		TM9-2320-280-24P				
(1)	(2)	(3)	(4)	(5)	(6)	(7)
ITEM NO	SMR CODE	NSN	CAGEC	PART NUMBER	DESCRIPTION AND USABLE ON CODES(UC)	QTY
19	PAOFF	2510014505480	19207	12340231-10	DOOR,VEHICULAR CAMOUFLAGE L.H. PART OF KIT P/N 57K3501..... UC:A13,A14,BVY,H13,H14,NNN	1
19	PAOFF	2510011899725	34623	5581349	DOOR,VEHICULAR GREEN,FRONT,R.H. PART OF KIT P/N 57K0123..... UC:A13,A14,BVY,H13,H14,NNN	1
19	PAOFF	2510014505479	19207	12340231-11	DOOR,VEHICULAR CAMOUFLAGE R.H. PART OF KIT P/N 57K3501..... UC:A13,A14,BVY,H13,H14,NNN	1
19	PAOFF	2510013306174	19207	12340231-3	DOOR,VEHICULAR L.H.,TAN PART OF KIT P/N 57K0155..... UC:A13,A14,BVY,H13,H14,NNN	1
19	PAOFF	2510013306175	19207	12340231-4	DOOR,VEHICULAR R.H.,TAN PART OF KIT P/N 57K0155..... UC:A13,A14,BVY,H13,H14,NNN	1
19	PAOFF	2510014076037	34623	12340231-5	DOOR,VEHICULAR L.H.,WHITE PART OF KIT P/N 57K0161..... UC:A13,A14,BVY,H13,H14,NNN	1
19	PAOFF	2510014076036	34623	12340231-6	DOOR,VEHICULAR R.H.,WHITE PART OF KIT P/N 57K0161..... UC:A13,A14,BVY,H13,H14,NNN	1
20	PAOZZ	5305000711327	96906	MS51960-70	.SCREW,MACHINE #10-32 X 1.25 PART OF KIT P/N 5705618 PART OF KIT P/N 5705619..... UC:A13,A14,BVY,H13,H14,NNN	1
21	PAOZZ	2540012001994	34623	5581320	.HANDLE,DOOR,VEHICUL L.H. PART OF KIT P/N 5705619..... UC:A13,A14,BVY,H13,H14,NNN	1
21	PAOZZ	2540012037721	34623	5581319	.HANDLE,DOOR,VEHICUL R.H. PART OF KIT P/N 5705618..... UC:A13,A14,BVY,H13,H14,NNN	1
22	PAOZZ	5360013157212	19207	12356764-1	.SPRING,HELICAL,TORS L.H. PART OF KIT P/N 5705619..... UC:A13,A14,BVY,H13,H14,NNN	1
22	PAOZZ	5360013157212	19207	12356764-1	.SPRING,HELICAL,TORS R.H. PART OF KIT P/N 5705618..... UC:A13,A14,BVY,H13,H14,NNN	1
23	PAOZZ	5310012059056	34623	5581321	.WASHER,FLAT .622 PART OF KIT P/N 5705618 PART OF KIT P/N 5705619..... UC:A13,A14,BVY,H13,H14,NNN	1
24	PAOZZ	2540012001995	19207	12301365	.HANDLE,DOOR,VEHICUL L.H. AND R.H. PART OF KIT P/N 5705618 PART OF KIT P/N 5705619..... UC:A13,A14,BVY,H13,H14,NNN	1
25	PAOZZ	5340012059021	19207	12340193-1	.LEAF,BUTT HINGE L.H. PART OF KIT P/N 5705618..... UC:A13,A14,BVY,H13,H14,NNN	2
25	PFOZZ	5340012059022	19207	12340193-2	.LEAF,BUTT HINGE R.H..... UC:A13,A14,BVY,H13,H14,NNN	2
26	PAOZZ	5305009881725	96906	MS35206-281	.SCREW,MACHINE 1/4-20 X 3/4..... UC:A13,A14,BVY,H13,H14,NNN	1
27	PAOZZ	5305000711315	96906	MS51957-79	.SCREW,MACHINE 1/4-20 X 1/2..... UC:A13,A14,BVY,H13,H14,NNN	3

SECTION II			TM9-2320-280-24P			
(1)	(2)	(3)	(4)	(5)	(6)	(7)
ITEM	SMR			PART		
NO	CODE	NSN	CAGEC	NUMBER	DESCRIPTION AND USABLE ON CODES(UC)	QTY
28	MOOZZ		41024	21022103-150IN.	.SEAL, NONMETALLIC SP MAKE FROM SEAL, P/N 21022103, 150 INCHES LONG... UOC:A13,A14,BVY,H13,H14,NNN	1
29	PAOZZ	5320010232529	81349	M24243/1A404	.RIVET, BLIND 1/8..... UOC:A13,A14,BVY,H13,H14,NNN	18
30	PAOZZ	5340012547189	19207	12340201	.LOOP, STRAP FASTENER PART OF KIT P/N 5705618..... UOC:A13,A14,BVY,H13,H14,NNN	1
31	PAOZZ	5310011520598	24617	271172	.NUT, SELF-LOCKING, AS 1/4-20..... UOC:A13,A14,BVY,H13,H14,NNN	4
32	PAOZZ	5340012569318	41024	41256040	.LOOP, STRAP FASTENER L.H..... UOC:A13,A14,BVY,H13,H14,NNN	1
32	PAOZZ	5340012559919	34623	5595217	.LOOP, STRAP FASTENER R.H..... UOC:A13,A14,BVY,H13,H14,NNN	1
33	PAFZZ	5325013571080	19207	12340212-3	.FASTENER, SLIDE, INTE..... UOC:A13,A14,BVY,H13,H14,NNN	1

END OF FIGURE

Section II.

TM 9-2320-280-24P-1

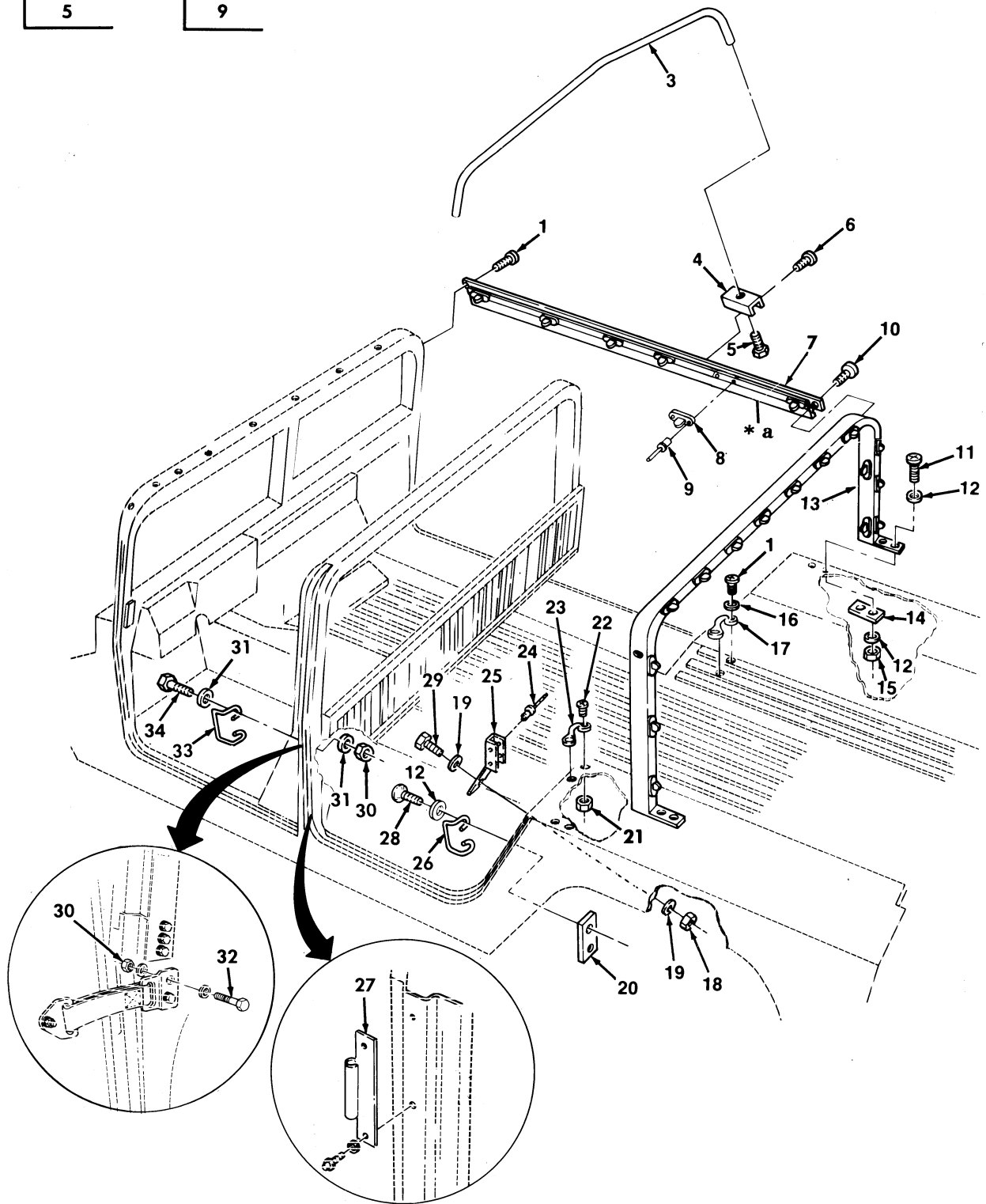
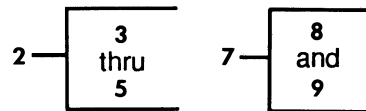

\* a PART OF ITEM 7

Figure 321. Four Man Crew Soft Top Enclosure, Bows, and Mounting Components.

SECTION II			TM9-2320-280-24P			
(1)	(2)	(3)	(4)	(5)	(6)	(7)
ITEM NO	SMR CODE	NSN	CAGEC	PART NUMBER	DESCRIPTION AND USABLE ON CODES(UC)	QTY
					GROUP 2201 CANVAS,RUBBER OR PLASTIC ITEMS	
					FIG. 321 FOUR MAN CREW SOFT TOP ENCLOSURE,BOWS,AND MOUNTING COMPONENTS	
1	PAOZZ	5305012106249	16941	PL25D02P12	SCREW,CAP,SOCKET HE #10-32 X 3/4... UOC:A13,A14,BVY,H13,H14,NNN	14
2	PFOZZ	2540011996759	19207	12340682	BOW,VEHICULAR TOP PART OF KIT P/N 57K0123 PART OF KIT P/N 57K0155 PART OF KIT P/N 57K0161 PART OF KIT P/N 57K3501..... UOC:A13,A14,BVY,H13,H14,NNN	2
3	PAOZZ	2540012064115	19207	12340713	.BOW,VEHICULAR TOP..... UOC:A13,A14,BVY,H13,H14,NNN	1
4	PFOZZ	5340012043862	19207	12340239	.STRAP,RETAINING..... UOC:A13,A14,BVY,H13,H14,NNN	2
5	PAOZZ	5305012038346	34623	5581439	.SCREW,CAP,SOCKET HE 1/4-20 X 3/8.. UOC:A13,A14,BVY,H13,H14,NNN	2
6	PAOZZ	5305000593659	96906	MS51958-63	SCREW,MACHINE #10-32 X 1/2 PART OF KIT P/N 57K0123 PART OF KIT P/N 57K0155 PART OF KIT P/N 57K0161 PART OF KIT P/N 57K3501..... UOC:A13,A14,BVY,H13,H14,NNN	8
7	PFOZZ	2590011961290	19207	12340222-1	HANDRAIL,VEHICULAR L.H.,GREEN PART OF KIT P/N 57K0123 PART OF KIT P/N 57K0155 PART OF KIT P/N 57K0161 PART OF KIT P/N 57K3501..... UOC:A13,A14,BVY,H13,H14,NNN	1
7	PFOZZ	2590011965314	19207	12340222-2	HANDRAIL,VEHICULAR R.H.,GREEN PART OF KIT P/N 57K0123 PART OF KIT P/N 57K0155 PART OF KIT P/N 57K0161 PART OF KIT P/N 57K3501..... UOC:A13,A14,BVY,H13,H14,NNN	1
8	PAOZZ	5325008235999	13940	XB78323-05001	.STUD,TURNBUTTON FAS L.H. AND R.H.. UOC:A13,A14,BVY,H13,H14,NNN	3
9	PAOZZ	5320000835009	81349	M24243/1-A403	.RIVET,BLIND L.H. AND R.H..... UOC:A13,A14,BVY,H13,H14,NNN	6
10	PAOZZ	5305011173396	80205	NAS1635-3LE12	SCREW,CAP,SOCKET HE #10-32 X 3/4 PART OF KIT P/N 57K0123 PART OF KIT P/N 57K0155 PART OF KIT P/N 57K0161 PART OF KIT P/N 57K3501..... UOC:A13,A14,BVY,H13,H14,NNN	2
11	PAOZZ	5305000680509	80204	B1821BH025C125N	SCREW,CAP,HEXAGON H 1/4-20..... UOC:A13,A14,BVY,H13,H14,NNN	4
12	PAOZZ	5310008094058	96906	MS27183-10	WASHER,FLAT 1/4..... UOC:A13,A14,BVY,H13,H14,NNN	8
13	PFOZZ	2540011961291	19207	12340679	BOW,VEHICULAR TOP PART OF KIT P/N 57K0123 PART OF KIT P/N 57K0155 PART OF KIT P/N 57K0161 PART OF KIT P/N 57K3501..... UOC:A13,A14,BVY,H13,H14,NNN	1

SECTION II			TM9-2320-280-24P			
(1)	(2)	(3)	(4)	(5)	(6)	(7)
ITEM NO	SMR CODE	NSN	CAGEC	PART NUMBER	DESCRIPTION AND USABLE ON CODES(UOC)	QTY
14	PAOZZ	5340012559510	19207	12339009	PLATE,MENDING..... UOC:A13,A14,BVY,H13,H14,NNN	2
15	PAOZZ	5310014326727	24617	9419471	NUT,SELF-LOCKING,HE 1/4-20 PART OF KIT P/N 57K0123 PART OF KIT P/N 57K0155 PART OF KIT P/N 57K0161 PART OF KIT P/N 57K3501..... UOC:A13,A14,BVY,H13,H14,NNN	4
16	PAOZZ	5310012349416	96906	MS51412-2	WASHER,FLAT #10..... UOC:A13,A14,BVY,H13,H14,NNN	4
17	PFOZZ	2510011995748	19207	12338839-8	LOOP,FOOTMAN,FLAT PART OF KIT P/N 57K0123 PART OF KIT P/N 57K0155 PART OF KIT P/N 57K0161 PART OF KIT P/N 57K3501..... UOC:A13,A14,BVY,H13,H14,NNN	2
18	PAOZZ	5310004838791	96906	MS17829-4F	NUT,SELF-LOCKING,HE #10-32 PART OF KIT P/N 57K0123 PART OF KIT P/N 57K0155 PART OF KIT P/N 57K0161 PART OF KIT P/N 57K3501..... UOC:A13,A14,BVY,H13,H14,NNN	2
19	PAOZZ	5310000814219	96906	MS27183-12	WASHER,FLAT PART OF KIT P/N 57K0123 PART OF KIT P/N 57K0155 PART OF KIT P/N 57K0161 PART OF KIT P/N 57K3501. UOC:A13,A14,BVY,H13,H14,NNN	4
20	PAOZZ	5340011975477	19207	12339006	RETAINER,ASSEMBLED..... UOC:A13,A14,BVY,H13,H14,NNN	2
21	PAOZZ	5310001249265	72582	271169	NUT,PLAIN,ASSEMBLED #10-32..... UOC:A13,A14,BVY,H13,H14,NNN	4
22	PAOZZ	5305011850114	7X677	157166	SCREW #10-32 X 3/4 PART OF KIT P/N 57K0123 PART OF KIT P/N 57K0155 PART OF KIT P/N 57K0161 PART OF KIT P/N 57K3501..... UOC:A13,A14,BVY,H13,H14,NNN	4
23	PAOZZ	5340011978673	19207	12338839-4	HANDLE,BOW ORDER NSN 5340-01-197- 8673 AND PAINT TAN PART OF KIT P/N 57K0123 PART OF KIT P/N 57K0155 PART OF KIT P/N 57K0161 PART OF KIT P/N 57K3501..... UOC:A13,A14,BVY,H13,H14,NNN	2
24	PAOZZ	5320010341884	11815	CR3243-6-5	RIVET,BLIND PART OF KIT P/N 57K0123 PART OF KIT P/N 57K0155 PART OF KIT P/N 57K0161 PART OF KIT P/N 57K3501. UOC:A13,A14,BVY,H13,H14,NNN	8
25	PAOZA	5340014309239	19207	12447124-1	BRACKET,MOUNTING R.H. PART OF KIT P/N 57K0123 PART OF KIT P/N 57K0155 PART OF KIT P/N 57K0161 PART OF KIT P/N 57K3501..... UOC:A13,A14,BVY,H13,H14,NNN	1
25	PAOZA	5340014309240	19207	12447123-1	BRACKET,MOUNTING L.H. PART OF KIT P/N 57K0123 PART OF KIT P/N 57K0155 PART OF KIT P/N 57K0161 PART OF KIT P/N 57K3501..... UOC:A13,A14,BVY,H13,H14,NNN	1
26	PAOZZ	5340012087670	19207	12340182-1	STRIKER,LATCH,DOOR L.H. PART OF KIT	1

SECTION II			TM9-2320-280-24P			
(1)	(2)	(3)	(4)	(5)	(6)	(7)
ITEM NO	SMR CODE	NSN	CAGEC	PART NUMBER	DESCRIPTION AND USABLE ON CODES(UC)	QTY
					P/N 57K0123 PART OF KIT P/N 57K0155 PART OF KIT P/N 57K0161 PART OF KIT P/N 57K3501..... UOC:A13,A14,BVY,H13,H14,NNN	
26	PAOZZ	5342012049610	19207	12340182-2	STRIKER,LATCH,DOOR R.H. PART OF KIT P/N 57K0123 PART OF KIT P/N 57K0155 PART OF KIT P/N 57K0161 PART OF KIT P/N 57K3501..... UOC:A13,A14,BVY,H13,H14,NNN	1
27	PAOZZ	5342012032822	19207	12338650	MOUNT,RESILIENT PART OF KIT P/N 57K0123 PART OF KIT P/N 57K0155 PART OF KIT P/N 57K0161 PART OF KIT P/N 57K3501..... UOC:A13,A14,BVY,H13,H14,NNN	4
28	PAOZZ	5305009881725	96906	MS35206-281	SCREW,MACHINE 1/4-20 X 3/4..... UOC:A13,A14,BVY,H13,H14,NNN	4
29	PAOZZ	5306000514077	80204	B1821BH031F113N	BOLT,MACHINE 5/16-24 X 1-1/8,PART OF KIT P/N 57K0123 PART OF KIT P/N 57K0155 PART OF KIT P/N 57K0161 PART OF KIT P/N 57K3501..... UOC:A13,A14,BVY,H13,H14,NNN	4
30	PAOZZ	5310002416658	96906	MS51943-34	NUT,SELF-LOCKING,HE 5/16-24,PART OF KIT P/N 57K0123 PART OF KIT P/N 57K0155 PART OF KIT P/N 57K0161 PART OF KIT P/N 57K3501..... UOC:A13,A14,BVY,H13,H14,NNN	12
31	PAOZZ	5310000814219	96906	MS27183-12	WASHER,FLAT 5/16..... UOC:A13,A14,BVY,H13,H14,NNN	8
32	PAOZZ	5306001802748	88044	AN5H7	BOLT,MACHINE 5/16-24 X 1.00 PART OF KIT P/N 57K0123 PART OF KIT P/N 57K0155 PART OF KIT P/N 57K0161 PART OF KIT P/N 57K3501..... UOC:A13,A14,BVY,H13,H14,NNN	4
33	PFOZZ	5340012070717	19207	12339187	BUCKLE..... UOC:A13,A14,BVY,H13,H14,NNN	2
34	PAOZZ	5306000514077	80204	B1821BH031F113N	BOLT,MACHINE 5/16-24 X 1-1/8..... UOC:A13,A14,BVY,H13,H14,NNN	4
KIT	PAOZZ	2540013166624	19207	57K0123	COVER,FITTED,VEHICU GREEN..... UOC:A13,A14,BVY,H13,H14,NNN	1
					BOLT,MACHINE ( 4) 321-29	
					BOLT,MACHINE ( 4) 321-32	
					BOW,VEHICULAR TOP ( 2) 321-2	
					BOW,VEHICULAR TOP ( 1) 321-13	
					BRACKET,MOUNTING ( 1) 321-25	
					BRACKET,MOUNTING ( 1) 321-25	
					CURTAIN,VEHICULAR ( 1) 320-2	
					DOOR ASSEMBLY ( 1) 320-5	
					DOOR ASSEMBLY ( 1) 320-5	
					DOOR,VEHICULAR ( 1) 320-19	
					DOOR,VEHICULAR ( 1) 320-19	
					HANDLE,BOW ( 2) 321-23	
					HANDRAIL,VEHICULAR ( 1) 321-7	
					HANDRAIL,VEHICULAR ( 1) 321-7	

SECTION II			TM9-2320-280-24P			
(1)	(2)	(3)	(4)	(5)	(6)	(7)
ITEM	SMR			PART		
NO	CODE	NSN	CAGEC	NUMBER	DESCRIPTION AND USABLE ON	CODES(UOC) QTY
					LOOP, FOOTMAN, FLAT	( 2) 321-17
					MOUNT, RESILIENT	( 4) 321-27
					NUT, SELF-LOCKING, HE	( 2) 321-18
					NUT, SELF-LOCKING, HE	( 2) 321-15
					NUT, SELF-LOCKING, HE	( 12) 321-30
					RIVET, BLIND	( 8) 321-24
					SCREW	( 4) 321-22
					SCREW, CAP, SOCKET HE	( 2) 321-10
					SCREW, MACHINE	( 8) 321-6
					STRIKER, LATCH, DOOR	( 1) 321-26
					STRIKER, LATCH, DOOR	( 1) 321-26
					TOP ASSEMBLY, TRUCK	( 1) 320-1
					WASHER, FLAT	( 4) 321-19
KIT PDOZZ	2540013298075	19207	57K0155		PARTS KIT, SOFT TOP TAN.....	1
					UOC:A13,A14,BVY,H13,H14,NNN	
					BOLT, MACHINE	( 4) 321-29
					BOLT, MACHINE	( 4) 321-32
					BOW, VEHICULAR TOP	( 2) 321-2
					BOW, VEHICULAR TOP	( 1) 321-13
					BRACKET, MOUNTING	( 1) 321-25
					BRACKET, MOUNTING	( 1) 321-25
					CURTAIN, VEHICULAR	( 1) 320-2
					DOOR ASSEMBLY	( 1) 320-5
					DOOR ASSEMBLY	( 1) 320-5
					DOOR, VEHICULAR	( 1) 320-19
					DOOR, VEHICULAR	( 1) 320-19
					HANDLE, BOW	( 2) 321-23
					HANDRAIL, VEHICULAR	( 1) 321-7
					HANDRAIL, VEHICULAR	( 1) 321-7
					LOOP, FOOTMAN, FLAT	( 2) 321-17
					MOUNT, RESILIENT	( 4) 321-27
					NUT, SELF-LOCKING, HE	( 2) 321-18
					NUT, SELF-LOCKING, HE	( 2) 321-15
					NUT, SELF-LOCKING, HE	( 12) 321-30
					RIVET, BLIND	( 8) 321-24
					SCREW	( 4) 321-22
					SCREW, CAP, SOCKET HE	( 2) 321-10
					SCREW, MACHINE	( 8) 321-6
					STRIKER, LATCH, DOOR	( 1) 321-26
					STRIKER, LATCH, DOOR	( 1) 321-26
					TOP ASSEMBLY, TRUCK	( 1) 320-1
					WASHER, FLAT	( 4) 321-19
KIT PDOZZ	2540014120929	19207	57K0161		COVER, FITTED, VEHICU WHITE.....	1
					UOC:A13,A14,BVY,H13,H14,NNN	
					BOLT, MACHINE	( 4) 321-29
					BOLT, MACHINE	( 4) 321-32
					BOW, VEHICULAR TOP	( 2) 321-2
					BOW, VEHICULAR TOP	( 1) 321-13
					BRACKET, MOUNTING	( 1) 321-25
					BRACKET, MOUNTING	( 1) 321-25
					CURTAIN, VEHICULAR	( 1) 320-2
					DOOR ASSEMBLY	( 1) 320-5
					DOOR ASSEMBLY	( 1) 320-5



SECTION II			TM9-2320-280-24P			
(1)	(2)	(3)	(4)	(5)	(6)	(7)
ITEM	SMR			PART		
NO	CODE	NSN	CAGEC	NUMBER	DESCRIPTION AND USABLE ON	CODES (UOC) QTY
					DOOR, VEHICULAR	( 1) 320-19
					DOOR, VEHICULAR	( 1) 320-19
					HANDLE, BOW	( 2) 321-23
					HANDRAIL, VEHICULAR	( 1) 321-7
					HANDRAIL, VEHICULAR	( 1) 321-7
					LOOP, FOOTMAN, FLAT	( 2) 321-17
					MOUNT, RESILIENT	( 4) 321-27
					NUT, SELF-LOCKING, HE	( 2) 321-18
					NUT, SELF-LOCKING, HE	( 2) 321-15
					NUT, SELF-LOCKING, HE	( 12) 321-30
					RIVET, BLIND	( 8) 321-24
					SCREW	( 4) 321-22
					SCREW, CAP, SOCKET HE	( 2) 321-10
					SCREW, MACHINE	( 8) 321-6
					STRIKER, LATCH, DOOR	( 1) 321-26
					STRIKER, LATCH, DOOR	( 1) 321-26
					TOP ASSEMBLY, TRUCK	( 1) 320-1
					WASHER, FLAT	( 4) 321-19
KIT PAOZZ	2540014348598	19207	57K3501		COVER, FITTED, VEHICU	STANDARD 1
					CAMOUFLAGE FOUR-MAN CREW.....	
					UOC:AVY, A13, A14, BVY, H13, H14, NNN	
					BOLT, MACHINE	( 4) 321-29
					BOLT, MACHINE	( 4) 321-32
					BOW, VEHICULAR TOP	( 2) 321-2
					BOW, VEHICULAR TOP	( 1) 321-13
					BRACKET, MOUNTING	( 1) 321-25
					BRACKET, MOUNTING	( 1) 321-25
					CURTAIN, VEHICULAR	( 1) 320-2
					DOOR ASSEMBLY	( 1) 320-5
					DOOR ASSEMBLY	( 1) 320-5
					DOOR, VEHICULAR	( 1) 320-19
					DOOR, VEHICULAR	( 1) 320-19
					HANDLE, BOW	( 2) 321-23
					HANDRAIL, VEHICULAR	( 1) 321-7
					HANDRAIL, VEHICULAR	( 1) 321-7
					LOOP, FOOTMAN, FLAT	( 2) 321-17
					MOUNT, RESILIENT	( 4) 321-27
					NUT, SELF-LOCKING, HE	( 2) 321-18
					NUT, SELF-LOCKING, HE	( 2) 321-15
					NUT, SELF-LOCKING, HE	( 12) 321-30
					RIVET, BLIND	( 8) 321-24
					SCREW	( 4) 321-22
					SCREW, CAP, SOCKET HE	( 2) 321-10
					SCREW, MACHINE	( 8) 321-6
					STRIKER, LATCH, DOOR	( 1) 321-26
					STRIKER, LATCH, DOOR	( 1) 321-26
					TOP ASSEMBLY, TRUCK	( 1) 320-1
					WASHER, FLAT	( 4) 321-19

END OF FIGURE

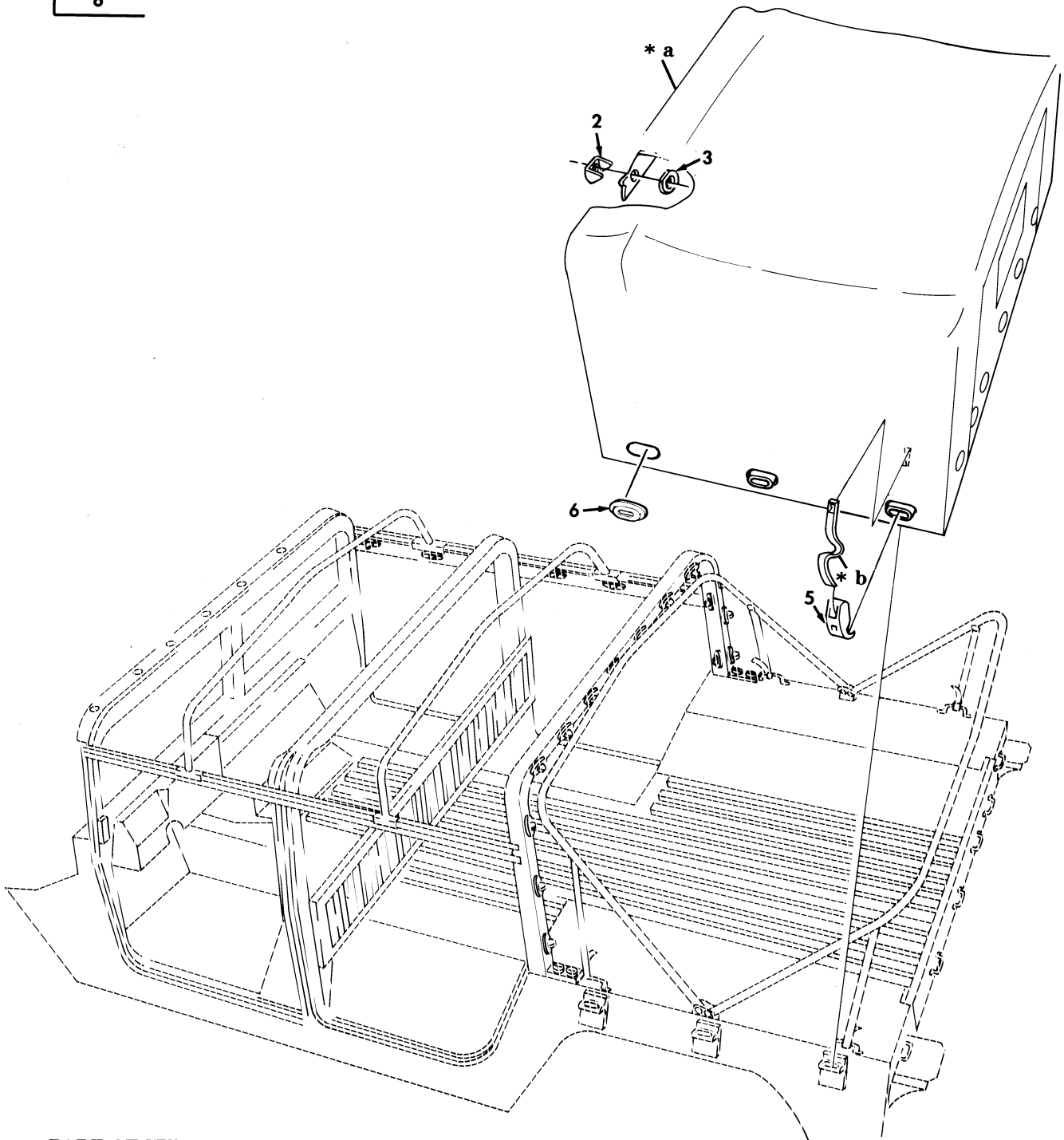
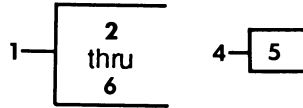

- \* a PART OF ITEM 1
- \* b PART OF ITEM 4

Figure 322. Cargo Area Soft Top Enclosure, Top Assembly.

SECTION II			TM9-2320-280-24P			
(1)	(2)	(3)	(4)	(5)	(6)	(7)
ITEM NO	SMR CODE	NSN	CAGEC	PART NUMBER	DESCRIPTION AND USABLE ON CODES(UC)	QTY
					GROUP 2201 CANVAS,RUBBER OR PLASTIC ITEMS	
					FIG. 322 CARGO AREA SOFT TOP ENCLOSURE, TOP ASSEMBLY	
1	PAOFF	2540011893707	19207	12340777	TOP ASSEMBLY,TRUCK GREEN PART OF KIT P/N 12340765.....	1
					UC:A13,A14,BVY,H13,H14,NNN	
1	PAOFF	2540014504020	19207	12340777-10	COVER,FITTED,VEHICU WHITE PART OF KIT P/N 57K0163.....	1
					UC:A13,A14,BVY,H13,H14,NNN	
1	PAOFF	2540014504024	19207	12340777-15	COVER,FITTED,VEHICU CAMOUFLAGE PART OF KIT P/N 57K3499.....	1
					UC:A13,A14,BVY,H13,H14,NNN	
1	PAOFF	2540013306170	19207	12340777-5	COVER,FITTED,VEHICU CARGO AREA, TAN PART OF KIT P/N 57K0158.....	1
					UC:A13,A14,BVY,H13,H14,NNN	
2	PAFZZ	5325002818643	13940	91-BS-78403	.SOCKET,TURNBUTTON F.....	5
					UC:A13,A14,BVY,H13,H14,NNN	
3	PAFZZ	5325003718108	13940	BS 78505	.CLINCH PLATE,TURNBU.....	5
					UC:A13,A14,BVY,H13,H14,NNN	
4	PAFZZ	5340011992206	34623	5581505	.STRAP,WEBBING.....	13
					UC:A13,A14,BVY,H13,H14,NNN	
5	PAOZZ	5340012036542	31272	44702-10	..BUCKLE.....	1
					UC:A13,A14,BVY,H13,H14,NNN	
6	PAOZZ	5325011992254	34623	5581315	.GROMMET, NONMETALLIC.....	13
					UC:A13,A14,BVY,H13,H14,NNN	

END OF FIGURE

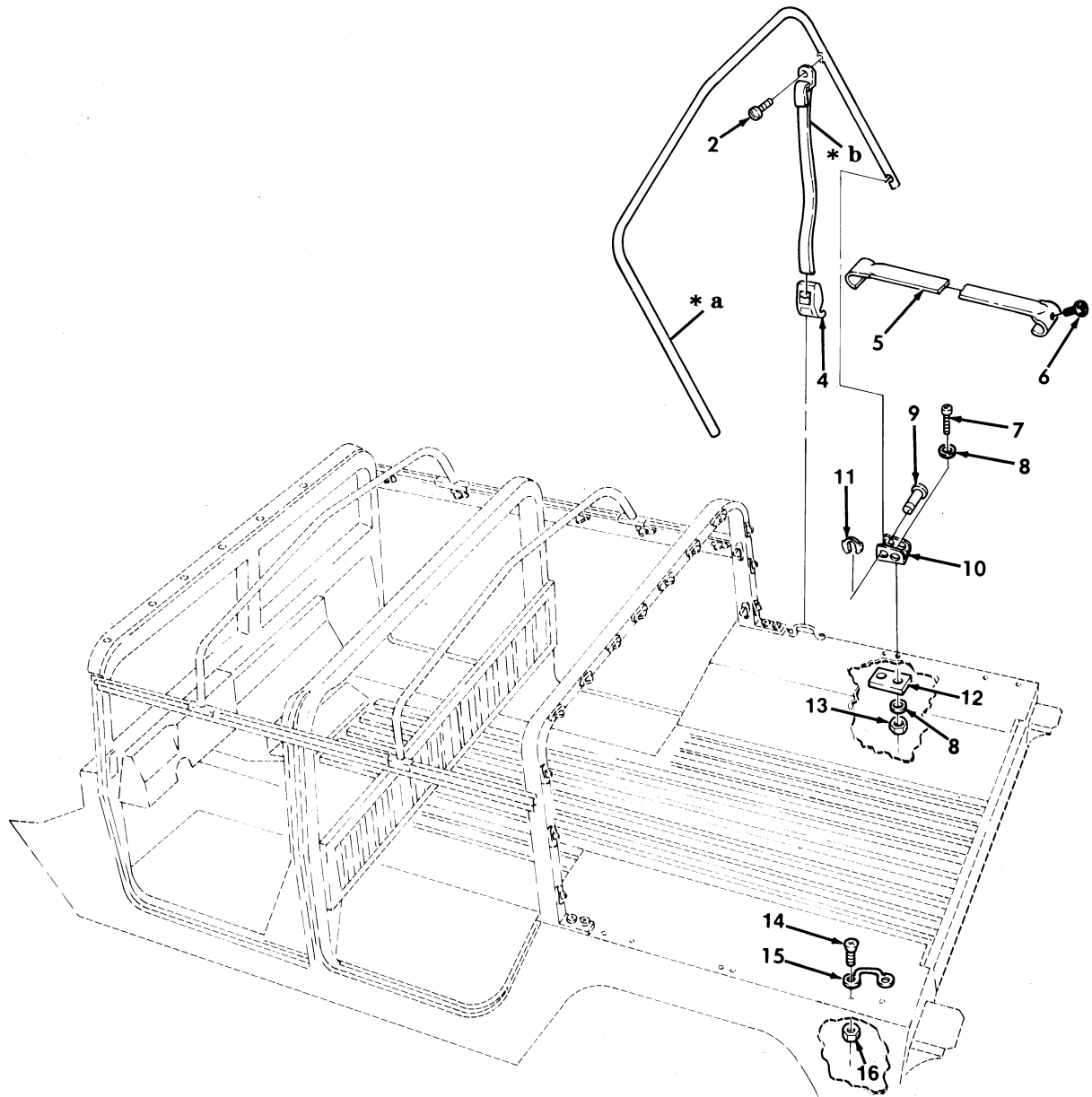
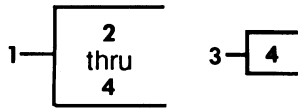

- \* a PART OF ITEM 1
- \* b PART OF ITEM 3

Figure 323. Cargo Area Soft Top Enclosure, Bows, and Mounting Components.

SECTION II			TM9-2320-280-24P			
(1)	(2)	(3)	(4)	(5)	(6)	(7)
ITEM NO	SMR CODE	NSN	CAGEC	PART NUMBER	DESCRIPTION AND USABLE ON CODES(UCO)	QTY
					GROUP 2201 CANVAS,RUBBER OR PLASTIC ITEMS	
					FIG. 323 CARGO AREA SOFT TOP ENCLOSURE,BOWS,AND MOUNTING COMPONENTS	
1	PFOOO	2540011978735	19207	12340768	BOW,VEHICULAR TOP PART OF KIT P/N 12340765,PART OF KIT P/N 57K0158, PART OF KIT P/N 57K0163,PART OF KIT P/N 57K3499.....	2
					UCO:A13,A14,BVY,H13,H14,NNN	
2	PAOZZ	5305011983385	16941	PL25D040P12	.SCREW,CAP,SOCKET HE #10-32 X 3/4..	2
					UCO:A13,A14,BVY,H13,H14,NNN	
3	PAOZZ	5340012027445	34623	5581464	.STRAP,WEBBING.....	2
					UCO:A13,A14,BVY,H13,H14,NNN	
4	PAOZZ	5340012036542	31272	44702-10	..BUCKLE.....	1
					UCO:A13,A14,BVY,H13,H14,NNN	
5	PAOZZ	2540013370242	19207	12342314	BOW CORNER,VEHICULA PART OF KIT P/N 12340765,PART OF KIT P/N 57K0158, PART OF KIT P/N 57K0163,PART OF KIT P/N 57K3499.....	1
					UCO:A13,A14,BVY,H13,H14,NNN	
6	PAOZZ	5305011090587	80205	MS24630-66	SCREW,TAPPING .190-32 X 3/8,PART OF KIT P/N 12340765,PART OF KIT P/N ... 57K0158,PART OF KIT P/N 57K0163,PART OF KIT P/N 57K3499.....	2
					UCO:A13,A14,BVY,H13,H14,NNN	
7	PAOZZ	5305011983385	16942	PL25D040P12	SCREW,SELF-LOCKING 1/4-20 X 3/4....	4
					UCO:A13,A14,BVY,H13,H14,NNN	
8	PAOZZ	5310008094058	96906	MS27183-10	WASHER,FLAT 1/4.....	8
					UCO:A13,A14,BVY,H13,H14,NNN	
9	PAOZZ	5315011971494	19207	12340209	PIN,GROOVED,HEADED 1/4 X 1.515,PART OF KIT P/N 12340765,PART OF KIT P/N 57K0158,PART OF KIT P/N 57K0163,PART OF KIT P/N 57K3499.....	4
					UCO:A13,A14,BVY,H13,H14,NNN	
10	PAOZZ	5340011999679	19207	12340196	STRAP,RETAINING PART OF KIT P/N 12340765,PART OF KIT P/N 57K0158, PART OF KIT P/N 57K0163,PART OF KIT P/N 57K3499.....	2
					UCO:A13,A14,BVY,H13,H14,NNN	
11	PAOZZ	5325010473201	19207	12340523	RING,RETAINING PART OF KIT P/N 12340765,PART OF KIT P/N 57K0158, PART OF KIT P/N 57K0163,PART OF KIT P/N 57K3499.....	4
					UCO:A13,A14,BVY,H13,H14,NNN	
12	PAOZZ	5340012559510	19207	12339009	PLATE,MENDING.....	2
					UCO:A13,A14,BVY,H13,H14,NNN	
13	PAOZZ	5310000614650	96906	MS51943-31	NUT,SELF-LOCKING,HE 1/4-20,PART OF KIT P/N 12340765,PART OF KIT P/N 57K0158,PART OF KIT P/N 57K0163,PART OF KIT P/N 57K3499.....	4
					UCO:A13,A14,BVY,H13,H14,NNN	

SECTION II			TM9-2320-280-24P			
(1)	(2)	(3)	(4)	(5)	(6)	(7)
ITEM NO	SMR CODE	NSN	CAGEC	PART NUMBER	DESCRIPTION AND USABLE ON CODES(UOC)	QTY
14	PAOZZ	5305009847343	96906	MS35191-276	SCREW,MACHINE #10-32 X 1.00,PART OF KIT P/N 12340765,PART OF KIT P/N 57K0158,PART OF KIT P/N 57K0163,PART OF KIT P/N 57K3499.....	8
					UOC:A13,A14,BVY,H13,H14,NNN	
15	PAOZZ	5340011978673	34623	12338839-4	HANDLE,BOW PART OF KIT P/N 12340765 PART OF KIT P/N 57K0158,PART OF KIT P/N 57K0163,PART OF KIT P/N 57K3499.	4
					UOC:A13,A14,BVY,H13,H14,NNN	
16	PAOZZ	5310001249265	72582	271169	NUT,PLAIN,ASSEMBLED #10-32,PART OF KIT P/N 12340765,PART OF KIT P/N 57K0158,PART OF KIT P/N 57K0163,PART OF KIT P/N 57K3499.....	8
					UOC:A13,A14,BVY,H13,H14,NNN	
KIT PDOZZ	2540011893461	19207	12340765		PARTS KIT,SOFT TOP GREEN.....	1
					UOC:A13,A14,BVY,H13,H14,NNN	
					BOW,CORNER,VEHICULA( 1) 323-5	
					BOW,VEHICULAR TOP ( 2) 323-1	
					HANDLE,BOW ( 4) 323-15	
					NUT,PLAIN,ASSEMBLED( 8) 323-16	
					NUT,SELF-LOCKING ( 4) 323-13	
					PIN,GROOVED,HEADED ( 4) 323-9	
					RING,RETAINING ( 4) 323-11	
					SCREW,TAPPING ( 2) 323-6	
					SCREW,TAPPING ( 8) 323-14	
					STRAP,RETAINING ( 2) 323-10	
					TOP ASSEMBLY,TRUCK ( 1) 322-1	
KIT PDOZZ	2540013298074	19207	57K0158		PARTS KIT,SOFT TOP TAN.....	1
					UOC:A13,A14,BVY,H13,H14,NNN	
					BOW,CORNER,VEHICULA( 1) 323-5	
					BOW,VEHICULAR TOP ( 2) 323-1	
					HANDLE,BOW ( 4) 323-15	
					NUT,PLAIN,ASSEMBLED( 8) 323-16	
					NUT,SELF-LOCKING ( 4) 323-13	
					PIN,GROOVED,HEADED ( 4) 323-9	
					RING,RETAINING ( 4) 323-11	
					SCREW,TAPPING ( 2) 323-6	
					SCREW,TAPPING ( 8) 323-14	
					STRAP,RETAINING ( 2) 323-10	
					TOP ASSEMBLY,TRUCK ( 1) 322-1	
KIT PDOZZ	2540014348599	19207	57K3499		PARTS KIT,SOFT TOP CAMO.....	1
					UOC:A13,A14,BVY,H13,H14,NNN	
					BOW,CORNER,VEHICULA( 1) 323-5	
					BOW,VEHICULAR TOP ( 2) 323-1	
					HANDLE,BOW ( 4) 323-15	
					NUT,PLAIN,ASSEMBLED( 8) 323-16	
					NUT,SELF-LOCKING ( 4) 323-13	
					PIN,GROOVED,HEADED ( 4) 323-9	
					RING,RETAINING ( 4) 323-11	
					SCREW,TAPPING ( 2) 323-6	
					SCREW,TAPPING ( 8) 323-14	
					STRAP,RETAINING ( 2) 323-10	
					TOP ASSEMBLY,TRUCK ( 1) 322-1	

SECTION II			TM9-2320-280-24P			
(1)	(2)	(3)	(4)	(5)	(6)	(7)
ITEM	SMR			PART		
NO	CODE	NSN	CAGEC	NUMBER	DESCRIPTION AND USABLE ON CODES(UOC)	QTY
KIT	PDOZZ	2540014511112	19207	57K0163	PARTS KIT,SOFT TOP WHITE.....	1
					UOC:A13,A14,BVY,H13,H14,NNN	
					BOW,CORNER,VEHICULA( 1) 323-5	
					BOW,VEHICULAR TOP ( 2) 323-1	
					HANDLE,BOW ( 4) 323-15	
					NUT,PLAIN,ASSEMBLED( 8) 323-16	
					NUT,SELF-LOCKING ( 4) 323-13	
					PIN,GROOVED,HEADED ( 4) 323-9	
					RING,RETAINING ( 4) 323-11	
					SCREW,TAPPING ( 2) 323-6	
					SCREW,TAPPING ( 8) 323-14	
					STRAP,RETAINING ( 2) 323-10	
					TOP ASSEMBLY,TRUCK ( 1) 322-1	

END OF FIGURE

Section II.

TM 9-2320-280-24P-1

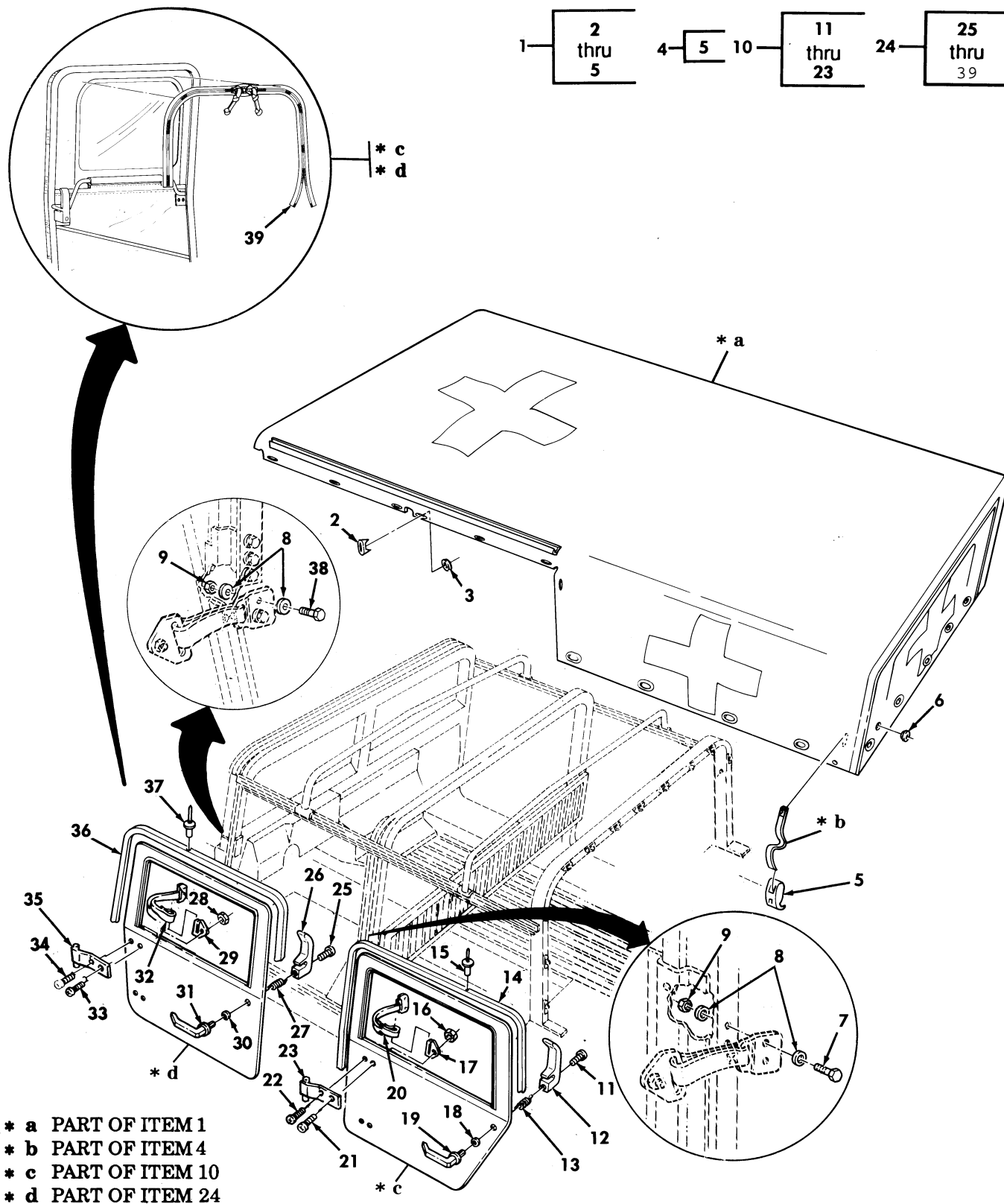

Figure 324. Ambulance Soft Top Enclosure, Top Curtain, and Door Assemblies.



SECTION II			TM9-2320-280-24P			
(1)	(2)	(3)	(4)	(5)	(6)	(7)
ITEM NO	SMR CODE	NSN	CAGEC	PART NUMBER	DESCRIPTION AND USABLE ON CODES(UOC)	QTY
GROUP 2201 CANVAS,RUBBER OR PLASTIC ITEMS						
FIG. 324 AMBULANCE SOFT TOP ENCLOSURE, TOP CURTAIN, AND DOOR ASSEMBLIES						
1	PAOFF	2540014762172	19207	12340226-2	COVER,FITTED,VEHICU CAMOUFLAGE.....	1
					UOC:A20,B20,H20	
1	PAOFF	2540011975478	19207	12340226	COVER,FITTED,VEHICU GREEN.....	1
					UOC:A20,B20,H20	
2	PAFZZ	5325002818643	13940	91-BS-78403	.SOCKET,TURNBUTON F.....	23
					UOC:A20,B20,H20	
3	PAFZZ	5325003718108	13940	BS 78505	.CLINCH PLATE,TURNBU.....	23
					UOC:A20,B20,H20	
4	PAFZZ	5340011992206	34623	5581505	.STRAP,WEBBING.....	14
					UOC:A20,B20,H20	
5	PAOZZ	5340012036542	31272	44702-10	..BUCKLE.....	1
					UOC:A20,B20,H20	
6	PAOZZ	5325011992254	34623	5581315	GROMMET,NONMETALLIC.....	13
					UOC:A20,B20,H20	
7	PAOZZ	5305000514076	80204	B1821BH031F100N	SCREW,CAP,HEXAGON H 5/6-24 X 1.00..	4
					UOC:A20,B20,H20	
8	PAOZZ	5310000814219	96906	MS27183-12	WASHER,FLAT 5/16.....	16
					UOC:A20,B20,H20	
9	PAOZZ	5310009843807	24617	9419476	NUT,SELF-LOCKING,HE 5/16-24.....	8
					UOC:A20,B20,H20	
10	PAOFF	2510011893459	41024	99890451	DOOR,VEHICULAR REAR,L.H.GREEN.....	1
					UOC:A20,B20,H20	
10	PAOFF	2510014505483	19207	12340245-8	DOOR,VEHICULAR CAMOUFLAGE L.H.....	1
					UOC:A20,B20,H20	
10	PAOFF	2510011893460	34623	SF5581351	DOOR,VEHICULAR REAR,R.H.GREEN.....	1
					UOC:A20,B20,H20	
10	PAOFF	2510014505482	19207	12340245-7	DOOR,VEHICULAR CAMOUFLAGE R.H.....	1
					UOC:A20,B20,H20	
11	PAOZZ	5305011981619	16941	PL25J02P20	.SCREW,MACHINE #10-32 X 1.25 PART OF KIT P/N 5705618 PART OF KIT P/N 5705619.....	1
					UOC:A20,B20,H20	
12	PAOZZ	2540012001994	34623	5581320	.HANDLE,DOOR,VEHICUL L.H. PART OF KIT P/N 5705619.....	1
					UOC:A20,B20,H20	
12	PAOZZ	2540012037721	19207	12301363-2	.HANDLE,DOOR,VEHICUL R.H. PART OF KIT P/N 5705618.....	1
					UOC:A20,B20,H20	
13	PAOZZ	5360013157211	19207	12356764-2	.SPRING,HELICAL,TORS R.H. PART OF KIT P/N 5705618.....	1
					UOC:A20,B20,H20	
13	PAOZZ	5360013157212	19207	12356764-1	.SPRING,HELICAL,TORS L.H. PART OF KIT P/N 5705619.....	1
					UOC:A20,B20,H20	
14	MOOZZ		41024	21022103-150	.SEAL,NONMETALLIC SP MAKE FROM SEAL, P/N 21022103, 150 INCHES LONG.	1

SECTION II			TM9-2320-280-24P			
(1)	(2)	(3)	(4)	(5)	(6)	(7)
ITEM NO	SMR CODE	NSN	CAGEC	PART NUMBER	DESCRIPTION AND USABLE ON CODES(UC)	QTY
15	PAOZZ	5320010232529	81349	M24243/1-A404	UC:A20,B20,H20 .RIVET,BLIND.....	18
16	PAOZZ	5310010185332	34623	5581461	UC:A20,B20,H20 .NUT,PLAIN,HEXAGON 1/4-20.....	4
17	PAOZZ	5340012569318	34623	5595216	UC:A20,B20,H20 .LOOP,STRAP FASTENER L.H.....	1
17	PAOZZ	5340012559919	34623	5595217	UC:A20,B20,H20 .LOOP,STRAP FASTENER R.H.....	1
18	PAOZZ	5310012059056	34623	5581321	UC:A20,B20,H20 .WASHER,FLAT 5/8 PART OF KIT P/N 5705618 PART OF KIT P/N 5705619.....	1
19	PAOZZ	2540012001995	19207	12301365	UC:A20,B20,H20 .HANDLE,DOOR,VEHICUL L.H. AND R.H. PART OF KIT P/N 5705618 PART OF KIT P/N 5705619.....	1
20	PAOZZ	5340012547189	19207	12340201	UC:A20,B20,H20 .LOOP,STRAP FASTENER.....	1
21	PAOZZ	5305012067217	16941	PL25D040P8	UC:A20,B20,H20 .SCREW,CAP,SOCKET HE 1/4-20 X 1/2..	3
22	PAOZZ	5305011983385	16941	PL25D040P12	UC:A20,B20,H20 .SCREW,CAP,SOCKET HE 1/4-20 X 3/4..	1
23	PAOZZ	5340012059021	19207	12340193-1	UC:A20,B20,H20 .LEAF,BUTT HINGE REAR,L.H.....	2
23	PFOZZ	5340012059022	19207	12340193-2	UC:A20,B20,H20 .LEAF,BUTT HINGE REAR,R.H.....	2
24	PAOFF	2510011899724	34623	5581348	UC:A20,B20,H20 DOOR ASSEMBLY,VEHIC FRONT,L.H.GREEN...	1
24	PAOFF	2510014505480	19207	12340231-10	UC:A20,B20,H20 DOOR,VEHICULAR CAMOUFLAGE L.H.FRONT	1
24	PAOFF	2510011899725	34623	5581349	UC:A20,B20,H20 DOOR,VEHICULAR FRONT,R.H.GREEN.....	1
24	PAOFF	2510014505479	19207	12340231-11	UC:A20,B20,H20 DOOR,VEHICULAR CAMOUFLAGE R.H., FRONT.....	1
25	PAOZZ	5305011981619	16941	PL25J02P20	UC:A20,B20,H20 .SCREW,MACHINE #10-32 X 1.25 PART OF KIT P/N 5705618 PART OF KIT P/N 5705619.....	1
26	PAOZZ	2540012001994	34623	5581320	UC:A20,B20,H20 .HANDLE,DOOR,VEHICUL L.H. PART OF KIT P/N 5705619.....	1
26	PAOZZ	2540012037721	34623	5581319	UC:A20,B20,H20 .HANDLE,DOOR,VEHICUL R.H. PART OF KIT P/N 5705618.....	1
27	PAOZZ	5360013157212	19207	12356764-1	UC:A20,B20,H20 .SPRING,HELICAL,TORS L.H. PART OF KIT P/N 5705619.....	1
27	PAOZZ	5360013157211	19207	12356764-2	UC:A20,B20,H20 .SPRING,HELICAL,TORS R.H. PART OF KIT P/N 5705618.....	1
28	PAOZZ	5310009971888	96906	MS35649-2252	UC:A20,B20,H20 .NUT,PLAIN,HEXAGON 1/4-20.....	4

SECTION II			TM9-2320-280-24P			
(1)	(2)	(3)	(4)	(5)	(6)	(7)
ITEM	SMR			PART		
NO	CODE	NSN	CAGEC	NUMBER	DESCRIPTION AND USABLE ON CODES(UC)	QTY
29	PAOZZ	5340012569318	41024	41256040	.LOOP,STRAP FASTENER L.H..... UC:A20,B20,H20	1
29	PAOZZ	5340012559919	34623	5595217	.LOOP,STRAP FASTENER R.H..... UC:A20,B20,H20	1
30	PAOZZ	5310012059056	34623	5581321	.WASHER,FLAT 5/8 PART OF KIT P/N 5705619..... UC:A20,B20,H20	1
31	PAOZZ	2540012001995	19207	12301365	.HANDLE,DOOR,VEHICUL L.H. AND R.H. PART OF KIT P/N 5705618 PART OF KIT P/N 5705619..... UC:A20,B20,H20	1
32	PAOZZ	5340012547189	19207	12340201	.LOOP,STRAP FASTENER..... UC:A20,B20,H20	1
33	PAOZZ	5305012067217	16941	PL25D040P8	.SCREW,CAP,SOCKET HE 1/4-20 X 1/2.. UC:A20,B20,H20	3
34	PAOZZ	5305011983385	16941	PL25D040P12	.SCREW,CAP,SOCKET HE 1/4-20 X 3/4.. UC:A20,B20,H20	1
35	PAOZZ	5340012059021	19207	12340193-1	.LEAF,BUTT HINGE L.H..... UC:A20,B20,H20	2
35	PFOZZ	5340012059022	19207	12340193-2	.LEAF,BUTT HINGE R.H..... UC:A20,B20,H20	2
36	MOOZZ		41024	21022103-150	.SEAL,NONMETALLIC SP MAKE FROM SEAL, P/N 21022103, 150 INCHES LONG. UC:A20,B20,H20	1
37	PAOZZ	5320010232529	81349	M24243/1A404	.RIVET,BLIND..... UC:A20,B20,H20	18
38	PAOZZ	5305006008993	19204	6008993	.SCREW,SHOULDER 5/16-24 X 1..... UC:A20,B20,H20	4
39	PAFZZ	5325013571080	19207	12340212-3	.FASTENER,SLIDE,INTE..... UC:A20,B20,H20	2

END OF FIGURE

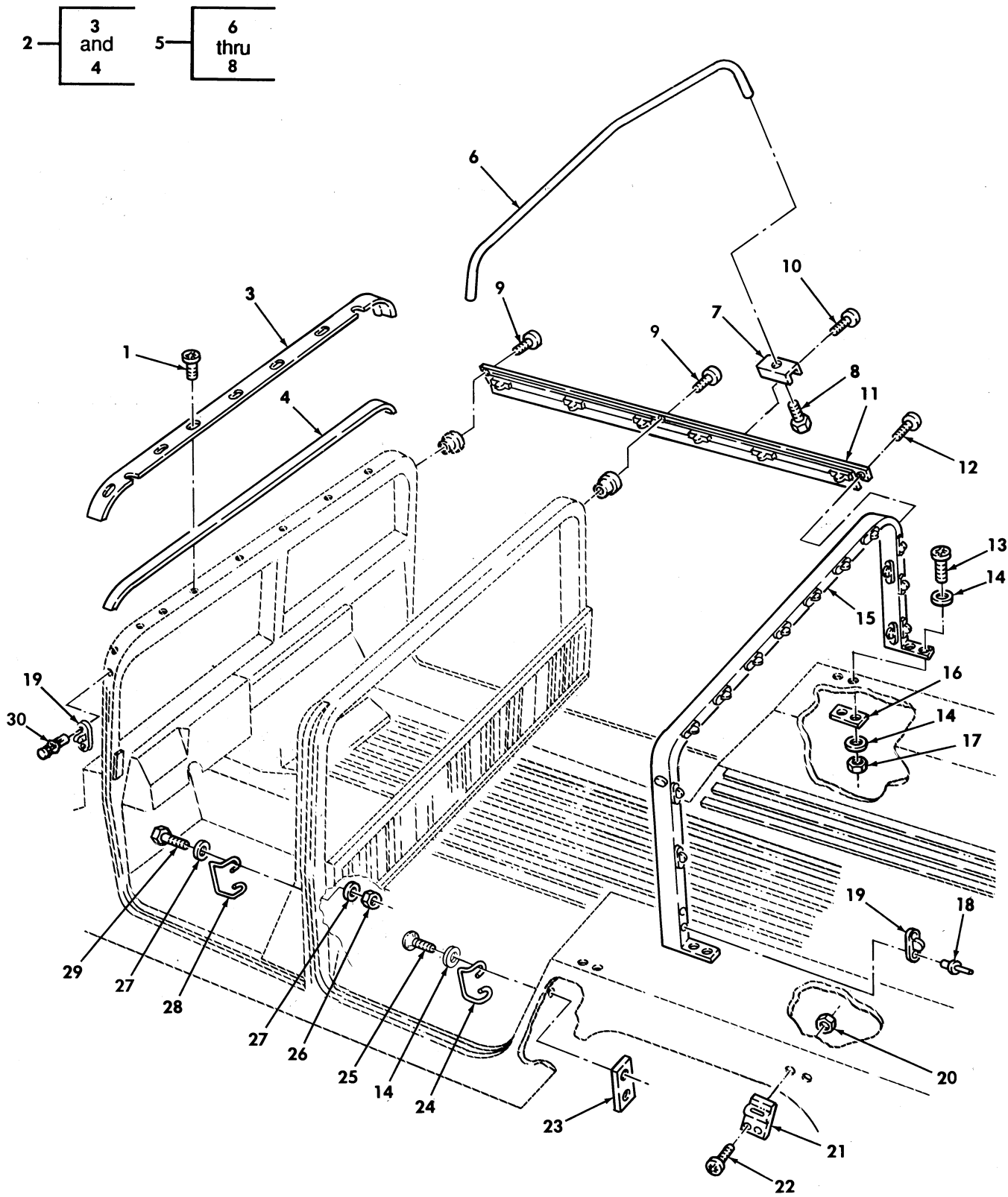

Figure 325. Ambulance Soft Top Enclosure, Bows, and Mounting Components.

SECTION II			TM9-2320-280-24P			
(1)	(2)	(3)	(4)	(5)	(6)	(7)
ITEM NO	SMR CODE	NSN	CAGEC	PART NUMBER	DESCRIPTION AND USABLE ON CODES(UOC)	QTY
					GROUP 2201 CANVAS,RUBBER OR PLASTIC ITEMS	
					FIG. 325 AMBULANCE SOFT TOP ENCLOSURE,BOWS,AND MOUNTING COMPONENTS	
1	PAOZZ	5305012106249	34634	G167084	SCREW MACHINE #10-34 X 1/2.....	11
					UOC:A20,B20,H20	
2	PFOZZ	2540011965313	19207	12340031	FORMER,PILLAR.....	1
					UOC:A20,B20,H20	
3	XAOZZ		34623	5581313	.FORMER.....	1
					UOC:A20,B20,H20	
4	MOOZZ		34623	5581366	.SEAL MAKE FROM TAPE,P/N 4965,82 INCHES LONG.....	1
					UOC:A20,B20,H20	
5	PFOOO	2540011975525	19207	12340241	BOW,VEHICULAR TOP.....	2
					UOC:A20,B20,H20	
6	XAOZZ		34623	5581396	.BOW.....	1
					UOC:A20,B20,H20	
7	PFOZZ	5340012043862	19207	12340239	.STRAP,RETAINING.....	2
					UOC:A20,B20,H20	
8	PAOZZ	5305012038346	34623	5581439	.SCREW,CAP,SOCKET HE 1/4-20 X 3/8..	2
					UOC:A20,B20,H20	
9	PAOZZ	5305009931848	96906	MS35207-265	SCREW,MACHINE #10-32 X 3/4.....	4
					UOC:A20,B20,H20	
10	PAOZZ	5305012080274	7X677	160046	SCREW,MACHINE #10-32 X 1/2.....	8
					UOC:A20,B20,H20	
11	PFOZZ	2590011961290	19207	12340222-1	HANDRAIL,VEHICULAR L.H.....	1
					UOC:A20,B20,H20	
11	PFOZZ	2590011965314	19207	12340222-2	HANDRAIL,VEHICULAR R.H.....	1
					UOC:A20,B20,H20	
12	PAOZZ	5305011173396	80205	NAS1635-3LE12	SCREW,CAP,SOCKET HE #10-32 X 3/4...	1
					UOC:A20,B20,H20	
13	PAOZZ	5305000712505	80204	B1821BH025C088N	SCREW,CAP,HEXAGON H 1/4-20 X 1.00..	4
					UOC:A20,B20,H20	
14	PAOZZ	5310008094058	96906	MS27183-10	WASHER,FLAT 1/4.....	12
					UOC:A20,B20,H20	
15	PFOZZ	2540011975476	34623	5581347	PILLAR ASSEMBLY,AMB.....	1
					UOC:A20,B20,H20	
16	PAOZZ	5340012559510	19207	12339009	PLATE,MENDING.....	4
					UOC:A20,B20,H20	
17	PAOZZ	5310014326727	24617	9419471	NUT,SELF-LOCKING,HE 1/4-20.....	4
					UOC:A20,B20,H20	
18	PAOZZ	5320000835009	81349	M24243/1-A403	RIVET,BLIND.....	8
					UOC:A20,B20,H20	
19	PAOZZ	5325008235999	13940	XB78323-05001	STUD,TURNBUTON FAS.....	6
					UOC:A20,B20,H20	
20	PAOZZ	5310001249265	11862	271169	NUT,PLAIN,ASSEMBLED #10-32.....	20
					UOC:A20,B20,H20	
21	PAOZZ	5340012609027	34623	5593625	LOOP,STRAP FASTENER.....	10
					UOC:A20,B20,H20	
22	PAOZZ	5305000593660	96906	MS51958-64	SCREW,MACHINE #10-32 X 5/8.....	20

SECTION II			TM9-2320-280-24P			
(1)	(2)	(3)	(4)	(5)	(6)	(7)
ITEM	SMR			PART		
NO	CODE	NSN	CAGEC	NUMBER	DESCRIPTION AND USABLE ON CODES(UC)	QTY
23	PAOZZ	5340011975477	19207	12339006	UOC:A20,B20,H20 RETAINER,ASSEMBLED.....	2
24	PAOZZ	5340012087670	19207	12340182-1	UOC:A20,B20,H20 STRIKER,LATCH,DOOR REAR DOOR,L.H...	2
24	PAOZZ	5342012049610	19207	12340182-2	UOC:A20,B20,H20 STRIKER,LATCH,DOOR REAR DOOR,R.H...	2
25	PAOZZ	5310009843807	24617	9419476	UOC:A20,B20,H20 NUT,SELF-LOCKING,HE 1/4-20 X 3/4...	4
26	PAOZZ	5310009843807	24617	9419476	UOC:A20,B20,H20 NUT,SELF-LOCKING,HE 5/16-24.....	4
27	PAOZZ	5310000814219	96906	MS27183-12	UOC:A20,B20,H20 WASHER,FLAT 5/16.....	8
28	PFOZZ	5340012070717	19207	12339187	UOC:A20,B20,H20 BUCKLE FRONT.....	2
29	PAOZZ	5306000514077	80204	B1821BH031F113N	UOC:A20,B20,H20 BOLT,MACHINE 5/16-24 X 1.13.....	4
30	PAOZZ	5320010232529	54402	AD44BS	UOC:A20,B20,H20 RIVET,BLIND 1/8.....	4

END OF FIGURE



SECTION II			TM9-2320-280-24P			
(1)	(2)	(3)	(4)	(5)	(6)	(7)
ITEM	SMR			PART		
NO	CODE	NSN	CAGEC	NUMBER	DESCRIPTION AND USABLE ON CODES(UC)	QTY
GROUP 2201 CANVAS,RUBBER OR PLASTIC ITEMS						
FIG. 326 AMBULANCE SOFT TOP ENCLOSURE,REAR BOW,AND MOUNTING COMPONENTS						
1	PAOOO	2540011975526	19207	12340199	BOW,VEHICULAR TOP.....	1
					UOC:A20,B20,H20	
2	PAOZZ	5305011983385	16941	PL25D040P12	.SCREW,CAP,SOCKET HE 1/4-20 X 3/4..	2
					UOC:A20,B20,H20	
3	PAOZZ	5340012027445	34623	5581464	.STRAP,WEBBING.....	2
					UOC:A20,B20,H20	
4	PAOZZ	5340012036542	31272	44702-10	..BUCKLE.....	1
					UOC:A20,B20,H20	
5	PAOZZ	5305011850114	7X677	157166	SCREW #10-32 X 5/8.....	10
					UOC:A20,B20,H20	
6	PAOZZ	5340011978673	19207	12338839-4	HANDLE,BOW.....	5
					UOC:A20,B20,H20	
7	PAOZZ	5310012510726	34623	5593053	NUT,SELF-LOCKING,HE #10-32.....	10
					UOC:A20,B20,H20	
8	PAOZZ	5315011971494	34623	5581392-B	PIN,GROOVED,HEADED 1/4 X 1.515.....	2
					UOC:A20,B20,H20	
9	PFOZZ	5340011999679	19207	12340196	STRAP,RETAINING.....	2
					UOC:A20,B20,H20	
10	PAOZZ	5325010473201	79136	5304-25-H	RING,RETAINING.....	2
					UOC:A20,B20,H20	
11	PAOZZ	5310008094058	96906	MS27183-10	WASHER,FLAT 1/4.....	8
					UOC:A20,B20,H20	
12	PAOZZ	5310014326727	24617	9419471	NUT,SELF-LOCKING,HE 1/4-20.....	4
					UOC:A20,B20,H20	
13	PAOZZ	5305000712505	80204	B1821BH025C088N	SCREW,CAP,HEXAGON H 1/4-20 X 7/8...	4
					UOC:A20,B20,H20	

END OF FIGURE



Section II.

TM 9-2320-280-24P-1

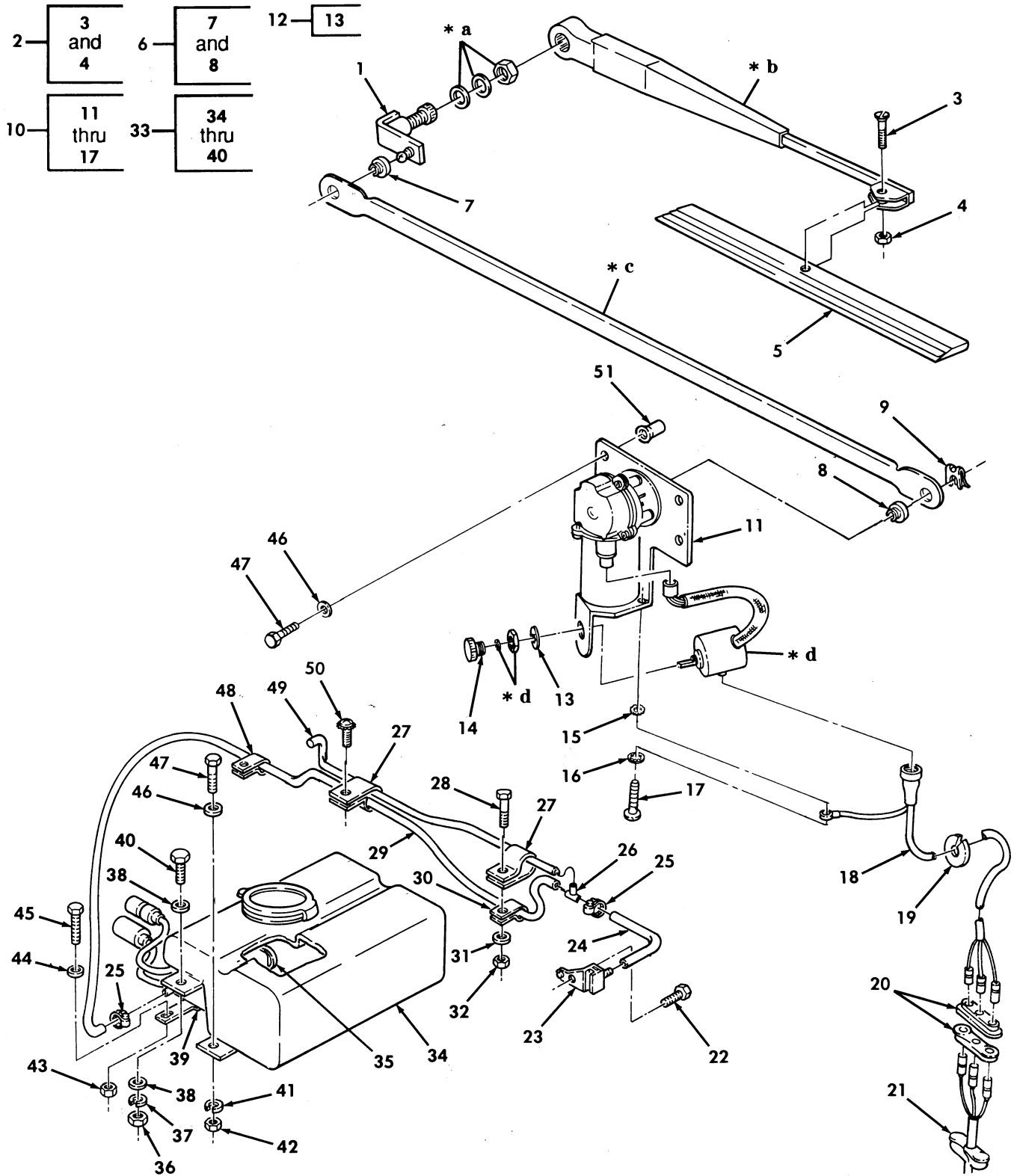

- \* a PART OF ITEM 1
- \* b PART OF ITEM 2
- \* c PART OF ITEM 6
- \* d PART OF ITEM 12

Figure 327. Windshield Wiper Motor, Wiper Assembly, and Washer Bottle.

SECTION II		TM9-2320-280-24P				
(1)	(2)	(3)	(4)	(5)	(6)	(7)
ITEM	SMR			PART		
NO	CODE	NSN	CAGEC	NUMBER	DESCRIPTION AND USABLE ON CODES(UOC)	QTY
GROUP 2202 ACCESSORY ITEMS						
FIG. 327 WINDSHIELD WIPER MOTOR, WIPER ASSEMBLY, AND WASHER BOTTLE						
1	PFOZZ	3040012106943	82484	GS-2176	LEVER, MANUAL CONTRO.....	2
2	PAOZZ	2540012124959	70412	13194	ARM, WINDSHIELD WIPE.....	2
3	PAOZZ	5305012297855	70412	62886	.SCREW, MACHINE 1/8 DIAMETER, 1/2 INCHES LONG.....	1
4	PAOZZ	5310012996460	72962	B79NM-50	.NUT, SELF-LOCKING, HE #5-40.....	1
5	PAOZZ	2540011997778	70412	51-11	BLADE, WINDSHIELD WI.....	2
6	PAOZZ	2540012141568	19207	12338831	PIVOT SHAFT, WINDSHI.....	2
7	PAOZZ	3120014321474	82484	S-3076	.BUSHING, SLEEVE CENTER.....	2
8	PAOZZ	3120013881527	82484	S-3087	.BUSHING, SLEEVE OUTER.....	2
9	PAOZZ	5340012115593	82484	C-1703	CLIP, SPRING TENSION.....	1
10	PAOZZ	2540011860969	19207	12342501	MOTOR, WINDSHIELD WI 24 VOLTS.....	1
11	XAOZZ		19207	12342501-1	.WIPER MOTOR.....	1
12	PAOZZ	5930013479216	19207	12342681	.SWITCH, ROTARY.....	1
13	PAOZZ	5310006853228	96906	MS35333-43	..WASHER, LOCK 7/16.....	1
14	PAOZZ	5355013536934	19207	12342682	.KNOB.....	1
15	PAOZZ	5310008892528	96906	MS45904-68	.WASHER, LOCK 1/4.....	1
16	PAOZZ	5310005501130	96906	MS35333-40	.WASHER, LOCK 1/4.....	2
17	PAOZZ	5305002044850	80205	MS24629-73	.SCREW, TAPPING 1/4-20 X 1/2.....	1
18	PAOZZ	6150011858240	19207	12339347-1	CABLE ASSEMBLY, SPEC.....	1
					UOC:AVY, A13, A14, A20, BVY, B20, HVY, H13, H14, H20, H21, H28, NNN	
18	PFOZZ	6150012103596	19207	12339347-2	CABLE ASSEMBLY, SPEC.....	1
					UOC:A11, A15, A24, A25, A26, A27, B15, B16, B17, B18, B25, C17, H11, H15, H16, H17, H18, H24, H25, H26, H27, MMM	
19	PAOZZ	5325010887468	96906	MS35489-41	GROMMET, NONMETALLIC.....	1
20	PFOZZ	5999011839530	19207	12339327	CONTACT ASSEMBLY, EL.....	1
					UOC:AVY, A13, A14, A20, BVY, B20, HVY, H13, H14, H20, H21, H28, NNN	
21	PAOZZ	5325012145007	34623	5579658	GROMMET, NONMETALLIC.....	1
					UOC:A11, A15, A24, A25, A26, A27, B15, B16, B17, B18, B25, C17, H11, H15, H16, H17, H18, H24, H25, H26, H27, MMM	
22	PAOZZ	5305012554611	34623	5593284	SCREW, TAPPING #8-32 X 5/8.....	2
23	PFOZZ	2540011845503	24866	D12604	NOZZLE, WINDSHIELD W.....	2
24	MOOZZ		34623	SF5585258	HOSE, NONMETALLIC MAKE FROM HOSE, P/N 846-50, 27 INCHES LONG.....	1
25	PAOZZ	4730000717890	81343	SAE J1508	CLAMP, HOSE.....	4
26	PAOZZ	4730010740060	60703	81087-5	TEE, HOSE.....	1
27	PAOZZ	5340002827517	96906	MS21333-42	CLAMP, LOOP.....	4
28	PAOZZ	5305002400194	96906	MS51849-76	SCREW, MACHINE #10-24 X 3/4.....	6
29	MOOZZ		34623	5585245	HOSE, NONMETALLIC MAKE FROM HOSE, P/N 846-50, 36 INCHES LONG.....	1
30	PAOZZ	5340008437825	96906	MS21333-68	CLAMP, LOOP.....	1
31	PAOZZ	5310012531618	96906	MS51412-18	WASHER, FLAT #10.....	14
32	PAOZZ	5310009349758	96906	MS35649-202	NUT, PLAIN, HEXAGON #10-24.....	7
33	PAOOO	2540013859000	ODPV2	203400	PUMP, WINDSHIELD WAS.....	1
34	PAOZZ	2540013868790	ODPV2	203600	.RESERVOIR, WINDSHIEL.....	1

SECTION II			TM9-2320-280-24P			
(1)	(2)	(3)	(4)	(5)	(6)	(7)
ITEM	SMR			PART		
NO	CODE	NSN	CAGEC	NUMBER	DESCRIPTION AND USABLE ON CODES(UOC)	QTY
35	PAOZZ	5330013811810	19207	12342886	.RETAINER,PACKING.....	1
36	PAOZZ	5310009349751	96906	MS35650-302	.NUT,PLAIN,HEXAGON #10-32.....	1
37	PAOZZ	5310000453296	96906	MS35338-43	.WASHER,LOCK #10.....	1
38	PAOZZ	5310012349416	96906	MS51412-2	.WASHER,FLAT #10.....	2
39	PAOZZ	2540013859031	ODPV2	203500	.PUMP,WINDSHIELD WAS.....	1
40	PAOZZ	5305011432328	72582	454065	.SCREW,CAP,HEXAGON H #10-32 X 3/4..	1
41	PAOZZ	5310005825965	96906	MS35338-44	WASHER,LOCK 1/4.....	2
42	PAOZZ	5310009050762	96906	MS51967-3	NUT,PLAIN,HEXAGON 1/4-20.....	2
43	PAOZZ	5310001249265	72582	271169	NUT,PLAIN,ASSEMBLED #10-32.....	1
44	PAOZZ	5310012349416	96906	MS51412-2	WASHER,FLAT #10.....	1
45	PAOZZ	5305005829501	82386	410-63	SCREW,CAP,HEXAGON H #10-32 X 1/2...	1
46	PAOZZ	5310008094058	96906	MS27183-10	WASHER,FLAT 1/4.....	2
47	PAOZZ	5305000680508	80204	B1821BH025C075N	SCREW,CAP,HEXAGON H 1/4-20 X 3/4...	2
48	PAOZZ	5340002862494	96906	MS21333-36	CLAMP,LOOP.....	4
49	MOOZZ		34623	SF5585243	HOSE,NONMETALLIC MAKE FROM HOSE,P/N 846-50, 16 INCHES LONG.....	1
50	PAOZZ	5305002406668	96906	MS51849-78	SCREW,MACHINE #10-24 X 1.00.....	1

END OF FIGURE



SECTION II			TM9-2320-280-24P			
(1)	(2)	(3)	(4)	(5)	(6)	(7)
ITEM NO	SMR CODE	NSN	CAGEC	PART NUMBER	DESCRIPTION AND USABLE ON CODES(UOC)	QTY
GROUP 2202 ACCESSORY ITEMS						
FIG. 328 REARVIEW MIRROR AND MOUNTING HARDWARE						
1	XBOOO		19207	12338828-1	ARM,REARVIEW MIRROR L.H.,USBL EFF 1 THRU 99,999..... UOC:H11,H13,H14,H15,H16,H17,H18,H20,H21,H24,H25,H26,H27,H28,MMM	1
1	XBOOO		19207	12338828-2	ARM,REARVIEW MIRROR R.H.,USBL EFF 1 THRU 99,999..... UOC:H11,H13,H14,H15,H16,H17,H18,H20,H21,H24,H25,H26,H27,H28,MMM	1
2	PAOZZ	5306002264829	80204	B1821BH031C125N	.BOLT,MACHINE 5/16-18 X 1.25,USBL EFF 1 THRU 99,999..... UOC:H11,H13,H14,H15,H16,H17,H18,H20,H21,H24,H25,H26,H27,H28,MMM	1
3	XBOZZ		19207	12338848	.BRACKET,MIRROR PIVO USBL EFF 1 THRU 99,999..... UOC:H11,H13,H14,H15,H16,H17,H18,H20,H21,H24,H25,H26,H27,H28,MMM	1
4	PAOZZ	5310011858692	34623	5585152	.WASHER,FLAT 3/8,USBL EFF 1 THRU 99,999..... UOC:H11,H13,H14,H15,H16,H17,H18,H20,H21,H24,H25,H26,H27,H28,MMM	2
5	XBOZZ		19207	12338847	.ARM,REARVIEW MIRROR USBL EFF 1 THRU 99,999..... UOC:H11,H13,H14,H15,H16,H17,H18,H20,H21,H24,H25,H26,H27,H28,MMM	1
6	PAOZZ	5310008140673	96906	MS51943-33	.NUT,SELF-LOCKING,HE 5/16-18,USBL EFF 1 THRU 99,999..... UOC:H11,H13,H14,H15,H16,H17,H18,H20,H21,H24,H25,H26,H27,H28,MMM	1
7	PAOZZ	5310004079566	96906	MS35338-45	.WASHER,LOCK 5/16,USBL EFF 1 THRU 99,999..... UOC:H11,H13,H14,H15,H16,H17,H18,H20,H21,H24,H25,H26,H27,H28,MMM	1
8	PAOZZ	5306002264826	80204	B1821BH031C088N	BOLT,MACHINE 5/16-18 X 7/8,USBL EFF 1 THRU 99,999..... UOC:H11,H13,H14,H15,H16,H17,H18,H20,H21,H24,H25,H26,H27,H28,MMM	8
9	PAOZZ	5310012520512	34623	5592832	WASHER,FLAT 5/16,USBL EFF 1 THRU 99,999..... UOC:H11,H13,H14,H15,H16,H17,H18,H20,H21,H24,H25,H26,H27,H28,MMM	8
10	PAOZZ	2540011845500	19207	12340025	ARM,REARVIEW MIRROR L.H.,USBL EFF 1 THRU 99,999..... UOC:H11,H13,H14,H15,H16,H17,H18,H20,H21,H24,H25,H26,H27,H28,MMM	1
10	XBOZZ		34623	5575967	ARM,REARVIEW MIRROR R.H.,USBL EFF 1 THRU 99,999..... UOC:H11,H13,H14,H15,H16,H17,H18,H20,H21,H24,H25,H26,H27,H28,MMM	1

SECTION II			TM9-2320-280-24P			
(1)	(2)	(3)	(4)	(5)	(6)	(7)
ITEM NO	SMR CODE	NSN	CAGEC	PART NUMBER	DESCRIPTION AND USABLE ON CODES(UC)	QTY
11	PAOZZ	5310012597554	34623	5597347	WASHER,FLAT 1/2,USBL EFF 1 THRU 99, 999..... UOC:H11,H13,H14,H15,H16,H17,H18,H20,H21,H24,H25,H26,H27,H28,MMM	2
12	PAOZZ	2540008400022	58536	A52432-1	MIRROR ASSEMBLY,REA USBL EFF 1 THRU 99,999..... UOC:H11,H13,H14,H15,H16,H17,H18,H20,H21,H24,H25,H26,H27,H28,MMM	2
13	PAOZZ	5310008775796	96906	MS21044-N4	.NUT,SELF-LOCKING,HE 1/4-28,USBL EFF 1 THRU 99,999..... UOC:H11,H13,H14,H15,H16,H17,H18,H20,H21,H24,H25,H26,H27,H28,MMM	1
14	PAOZZ	5310008094058	96906	MS27183-10	.WASHER,FLAT 9/32,USBL EFF 1 THRU 99,999..... UOC:H11,H13,H14,H15,H16,H17,H18,H20,H21,H24,H25,H26,H27,H28,MMM	1
15	PAOZZ	5310008140673	96906	MS51943-33	NUT,SELF-LOCKING,HE 5/16-18,USBL EFF 1 THRU 99,999..... UOC:H11,H13,H14,H15,H16,H17,H18,H20,H21,H24,H25,H26,H27,H28,MMM	8
16	PAOZZ	5310012560416	34623	5595964	NUT,PLAIN,ROUND USBL EFF 1 THRU 99, 999..... UOC:H11,H13,H14,H15,H16,H17,H18,H20,H21,H24,H25,H26,H27,H28,MMM	2
17	PAOZZ	5310006379541	96906	MS35338-46	WASHER,LOCK 3/8,USBL EFF 1 THRU 99, 999..... UOC:H11,H13,H14,H15,H16,H17,H18,H20,H21,H24,H25,H26,H27,H28,MMM	2
18	PAOZZ	5310000806004	96906	MS27183-14	WASHER,FLAT 3/8,USBL EFF 1 THRU 99, 999..... UOC:H11,H13,H14,H15,H16,H17,H18,H20,H21,H24,H25,H26,H27,H28,MMM	2

END OF FIGURE

By Order of the Secretary of the Army:

ERIC K. SHINSEKI  
*General, United States Army*  
*Chief of Staff*

Official:

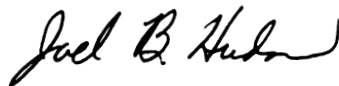

JOEL B. HUDSON  
*Administrative Assistant to the*  
*Secretary of the Army*  
05695

By Order of the Secretary of the Air Force:

RONALD R. FOGLEMAN  
*General, United States Air Force*  
*Chief of Staff*

Official:

HENRY VICCELLIO, JR.  
*General, United States Air Force*  
*Commander, Air Force Materiel Command*

Distribution:

To be distributed in accordance with the initial distribution number (IDN) 381008, requirements for TM 9-2320-280-24P-1.



THEN . . . JOT DOWN THE DOPE ABOUT IT ON THIS FORM. CAREFULLY TEAR IT OUT. FOLD IT AND DROP IT IN THE MAIL!

# SOMETHING WRONG

WITH THIS PUBLICATION?

FROM: (PRINT YOUR UNIT'S COMPLETE ADDRESS)

Your Mailing Address

DATE SENT

Date You Filled Out This Form

PUBLICATION NUMBER

TM 9-2320-280-24P-1

PUBLICATION DATE

30 March 2001

PUBLICATION TITLE

Unit, Direct and General Support Maintenance Repair Parts and Special Tools List

BE EXACT. . . PIN-POINT WHERE IT IS

IN THIS SPACE TELL WHAT IS WRONG AND WHAT SHOULD BE DONE ABOUT IT:

PAGE NO.	PARA-GRAPH	FIGURE NO.	TABLE NO.
----------	------------	------------	-----------

42-1

42

Item No. 3, Washer, Flat NSN 5310-01-251-0747 Should read 5310-00-595-6057

**SAMPLE**

PRINTED NAME, GRADE OR TITLE, AND TELEPHONE NUMBERS

Your Name, Rank, and Phone Number

SIGN HERE:

PFC John Doe



**SAMPLE**

FILL IN YOUR  
UNIT'S ADDRESS



FOLD BACK

DEPARTMENT OF THE ARMY

---

---

TEAR ALONG PERFORATED LINE

AMSTA-LC-CI/TECH PUBS, TACOM-RI  
1 ROCK ISLAND ARSENAL  
ROCK ISLAND, IL 61299-7630



*THEN . . . JOT DOWN THE DOPE ABOUT IT ON THIS FORM. CAREFULLY TEAR IT OUT. FOLD IT AND DROP IT IN THE MAIL!*

# SOMETHING WRONG

WITH THIS PUBLICATION?

FROM: (PRINT YOUR UNIT'S COMPLETE ADDRESS)

DATE SENT

PUBLICATION NUMBER

**TM 9-2320-280-24P-1**

PUBLICATION DATE

**30 March 2001**

PUBLICATION TITLE

**Unit, Direct and General Support Maintenance Repair Parts and Special Tools List**

BE EXACT. . . PIN-POINT WHERE IT IS

IN THIS SPACE TELL WHAT IS WRONG AND WHAT SHOULD BE DONE ABOUT IT:

PAGE NO.	PARA-GRAPH	FIGURE NO.	TABLE NO.

PRINTED NAME, GRADE OR TITLE, AND TELEPHONE NUMBERS

SIGN HERE:

FILL IN YOUR  
UNIT'S ADDRESS



FOLD BACK

DEPARTMENT OF THE ARMY

---

---

TEAR ALONG PERFORATED LINE

AMSTA-LC-CI/TECH PUBS, TACOM-RI  
1 ROCK ISLAND ARSENAL  
ROCK ISLAND, IL 61299-7630

